



Our 2025 Training course portfolio

THINK STEAM TRAINING, THINK SPIRAX SARCO



First for Steam Solutions
EXPERTISE | SOLUTIONS | SUSTAINABILITY





Welcome	4
Our training heritage and how we support you	6
Your course, Your way. Your choice	8
Our Training Centre Facilities	10
Correspondence courses	14
Meet the trainers who inspire	16
First class support	18
Rewarding competence	20
Course progression routes	22
New to Steam Courses	24
Introduction to Steam and Condensate Systems City & Guilds Accredited	26
Steam Boiler Operation Fundamentals City & Guilds Accredited	28
Boiler house Courses	30
Steam Boiler Operation Fundamentals City & Guilds Accredited	32
Boiler Operation Accreditation Scheme (BOAS-Operator and Manager including Renewal)	34
Boiler House Guidance, Regulations and Risk Assessment for Managers	36
Boiler House Water Treatment City & Guilds Accredited	38



Maintenance Courses	40
Steam Plant Maintenance City & Guilds Accredited	42
Safety Valve Accreditation	44
Specialist Courses	46
Steam Quality Testing City & Guilds Accredited	48
Design of Steam and Condensate Systems City & Guilds Accredited	50
Specialist and Bespoke training	52
Building the case for investing in training	54
Next steps	
How to book	56
Get in touch	57
You're in good company	58



Welcome

Where has this year gone?

It's been another fabulous year and thank you to all our customers, new and old for making it so busy! The demand for our courses has remained overwhelming and we love being your first choice for training your teams. Based on the feedback about the quality, content and delivery of our courses, you are clearly enjoying your experience with us!

World economics and events remained turbulent and challenging and as I reflect on what has occurred this year, it is clear to me that ensuring your teams have the knowledge and skills to deal with these changing demands remains incredibly important. Safety should remain your number one priority and it's also at the heart of all our training so you can be assured that your teams leave us with the skills and knowledge to ensure they are working safely, sustainably and efficiently.

Once again we have experienced some changes, the company has changed its name to Spirax Group, updated its branding and opened its new sustainable Group Headquarters, so we have a stunning BREEAM rated outstanding building to view from our training centre.



We have also welcomed a new team member, Laura, who joined us in October, is here to support the trainers and ensure we provide you all with that fabulous customer experience.

We are also working on some new courses that will be released through 2025 so keep an eye out for details of these and let me know if you want to join our mailing list so you can be the first to hear about new developments, including other exciting projects we are working on.

We remain passionate about supporting you and your business in your learning journey and look forward to welcoming many more of you soon. Don't forget we are all on LinkedIn if you would like to connect, we post an eclectic mix of information to keep you updated through the year!



Best wishes for 2025 and look forward to welcoming you soon.

Sally O'Connell

**UK Steam Technology
Centre Manager**



**Spirax
Sarco**

UK Steam Technology Centre

**Our training
heritage and how
we support you >**



Customer training has a long history in Spirax Sarco with the first recorded technical education correspondence courses being provided during WWII, and the first in-house training taking place shortly afterwards.

Training is all about people, and it's our people who make us different. They have a passion and an unparalleled understanding of the application of steam across a wide range of industries, which enables us to ensure our courses are current and relevant to your industry needs.

Our approach to training ensures we focus on providing the skills and knowledge that can be applied back in the workplace, helping your business to:

- Increase steam safety
- Demonstrate competence and enhance skill levels
- Maximise the efficiency and sustainability of your steam systems
- Adhere to relevant legislation around training (e.g. PUWER, BG01)
- Review process and operational improvements



**Your course,
Your way,
Your choice >**



In 2021 we introduced Spirax Choices, offering you the flexibility to attend training in the way that suits you and your organisation.

Whilst providing practical face-to-face training is always the preference, 'Spirax Choices' offers the following options across our portfolio. We have highlighted next to each course which option is available.

Webinars and ongoing support - The Knowledge Hub

We offer a webinar programme to provide you and your teams with additional support in key areas. You can register for on demand webinars at <https://www.spiraxsarco.com/global/en-GB/knowledge-hub>



Face-to-Face
classroom training



Remote live
classroom delivery
via a web platform



Onsite delivery at your site



Blended learning options -
combining remote live and
Face-to-Face training



Our training centre facilities >

Being able to practice key skills in a safe and controlled environment helps individuals to apply their knowledge when they return to the workplace. That's why we provide our delegates with the opportunity for safe hands on experience in our fully operational boiler house, demonstration and practical areas so they really will be able to put the theory into practice.

Practical Area



**PRESSURE
REDUCING
VALVE RIGS**



**STEAM TRAP
TESTING RIG**



**STEAM TRAP
BUILDING
STATIONS**



**STEAM TRAP
DEMONSTRATION RIG**



PUMP RIGS

Boiler house



Demonstration Area



Training rooms



Fully equipped training facilities offering flexible seating



Product cut-sections available to help understand how they work



Comfortable delegate areas for breaks and refreshments



Lunch in our outstanding Bistro – your choice from the menu

Head to <https://www.youtube.com/user/SpiraxSarcoUK> to check out a virtual tour of our training centre.

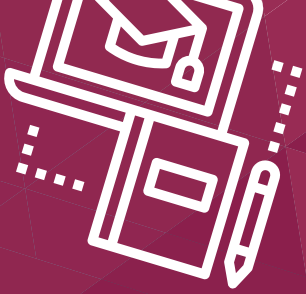

Correspondence courses >



Did you know we also provide some complimentary learning support materials?

We know that some of you may wish to brush up on your knowledge before attending a course, or perhaps you are undecided about committing to a full training course at this stage. Our comprehensive correspondence courses are available in the following subjects.

Automatic Controls – An Introduction

Providing a basic introduction to automatic controls, with specific emphasis on temperature control.

Hot Water Heating

Focusing on an important part of the building services package - the hot water heating system. This course broadly covers some aspects of its design and function.

Steam Utilisation

A comprehensive course covering the properties of steam, making the best use of steam and steam plants and understanding how to become more efficient.

Each course is stand alone but they do complement the scheduled courses on offer.

If you would like to register for one of these courses then visit our website at spiraxsarco.com/global/en-GB/training and complete the registration form.



Meet the trainers who inspire >

At Spirax Sarco you will learn from experienced trainers and practitioners. You will receive first hand and up to date knowledge directly from those in the know.

We like to introduce opportunities to complete practical elements to aid the learning and our trainers are all committed to your development. So you receive the correct training for your job role whilst feeling confident you are introduced to the latest industry guidance and legislation.

"I try and make my training sessions fun, informative and use the delegates own experiences where possible.

I strive to get that light bulb moment from the delegates where they have worked out their own solution to their own problem by giving them the knowledge around the subject."

MIKE MASLANKA Cert IBO DipBOM >
UK Steam Technology Centre Trainer



"It's great to see people go from little or no knowledge, even perhaps wondering why they've been sent on the course - to becoming competent in what we are training them in, and be enthused by the subject.

I love to hear from delegates – get discussions going, so we can learn from each other's experiences – as well as through the official course content."

< TOM SUWART Cert IBO DipBOM
UK Steam Technology Centre Trainer

"One of my favourite things is that you meet a wide range of people from a variety of industries and level of experience.

Whilst theoretical knowledge is important for each course, I believe it is equally valuable for delegates to work collaboratively and share their ideas in a supportive environment. It is very pleasing when delegates regularly show an interest in coming back for additional courses."

LEWIS GANI >
UK Steam Technology Centre Trainer



First class support >

"Our team ethos is to support and help those attending our courses to learn and take that knowledge back to the workplace and apply it! We are a passionate team with a wealth of knowledge and experience and we love sharing this with our customers, helping to improve their skills and knowledge and helping businesses to operate safely, efficiently and sustainably."

SALLY O'CONNELL Cert Ed, BA, MSc >

UK Steam Technology Centre Manager



"I get satisfaction in supporting individuals to identify the appropriate training required through to leaving the course pleased with their success. I enjoy liaising with external customers to support their employees improve performance through the correct course."

The support we provide removes obstacles individuals may have with learning so that they achieve the learning outcomes. Our trainers inspire people to want to learn and are really enthusiastic on the subject they are delivering."

< CHRISTINE TIMMINS

UK Steam Technology Centre Administrator

"I really enjoy meeting and greeting the customers that come through our Training Centre doors. It's a real pleasure to help them feel at ease and make them comfortable and supported on their training journey with us. I also have a huge admiration for our team and take great satisfaction in making sure they are all assisted throughout their day, helping to make their training courses run smoothly and successfully."

LAURA BOUND >

UK Steam Technology Centre Assistant



Training is part of an individual's learning journey and we understand how choosing the right course at the right time ensures they gain the maximum benefit personally but also for your business when they return.

Not sure which course, ask us!

We love having conversations about which course is the most suitable for your requirements. We are happy to make recommendations based on our experience with other delegates and our knowledge on legislative requirements and course content. We know that steam may not be your specialism, but it is ours, so let us support you in making the right decision for you and your business needs.

Additional Learning Support

Some of our courses have examination requirements and we are able to provide additional learning support facilities for those who may have a learning difficulty such as dyslexia. We will discuss this on an individual basis to find the most suitable option for each individual.

Boiler Operation Accreditation Scheme (BOAS) support

We take our role as an Approved Training Provider for BOAS very seriously. We want to ensure that the process to certification is as smooth as possible so we will work with you ahead of your attendance to make sure you are eligible and that all the assessment requirements are in place. Our responsibilities don't stop when you have attended the training, we are with you until you receive your certification.

In addition, we will be there in the intervening 5 year period to support and remind you ahead of the renewal date so you have continuity of cover.

Availability / Quotes / Booking Process

Details on our booking process is detailed further on page 56.

Our latest course dates are always updated on the website. If you want to check availability then let us know. We monitor uptake throughout the year and will add in further dates as necessary to match demand so you can be assured that the right course is available when you need it.



Rewarding competence >

We are frequently asked how you can demonstrate that your team are competent to do their job. We work with a selection of organisations to accredit our courses to help you fulfil this need.



City & Guilds

City & Guilds is a world leader in skills development with over 140 years of unrivalled experience. The majority of our courses have achieved accreditation to provide you with the reassurance they are of the highest quality. We are continually working on the accreditation of the remaining courses.



Combustion Engineering Association (CEA)

The CEA is an educational charity which aims to promote the science of combustion engineering. We are an approved training provider of the Boiler Operator Accreditation Scheme (BOAS) for boiler operators and managers.



Continuing Professional Development

We are committed to the principles of continual learning and demonstration of best practice. The majority of our courses are therefore also available as evidence of continuing professional development (CPD) through the Chartered Institution of Building Services Engineers (CIBSE).



Institute of Healthcare Engineering and Estate Management (IHEEM)

IHEEM is the UK's largest specialist Institute for the Healthcare Estates Sector. We are proud to be an approved Knowledge Partner offering courses relevant for those employed in the healthcare estates sector.

Course progression routes >

Learning is a journey and training is one element of that process. That's why we have developed our courses to allow you and your team to build your skills and knowledge over a range of topics and period of time, helping you to feel confident to apply the skills and knowledge acquired back in the workplace.

ARE YOU?



**MAINTAINING
STEAM SYSTEMS**



**OPERATING
STEAM SYSTEMS**



**MANAGING
STEAM SYSTEMS**

▶ YOU NEED...



Introduction to Steam and Condensate Systems (B1)



3 MONTHS EXPERIENCE



Steam Plant Maintenance (M2)



Safety Valve Accreditation (M3)



Introduction to Steam and Condensate Systems (B1)



3 MONTHS EXPERIENCE



Steam Boiler Plant Fundamentals (D6S)



6 MONTHS+ EXPERIENCE



Boiler Operation Accreditation Scheme (BOAS) & Renewal* (D6A & D6AR)



Boiler House Water Treatment (W1)



Introduction to Steam and Condensate Systems (B1)



Steam Boiler Plant Fundamentals (D6S)



Boiler Operation Accreditation Scheme (BOAS) & Renewal* (D6A & D6AR)



Boiler House Water Treatment (W1)



Boiler Guidance, Regulations and Risk Assessment (RA1)

3 MONTHS EXPERIENCE

6 MONTHS+ EXPERIENCE

*five yearly

NEW TO STEAM COURSES

These courses provide an introduction to the world of steam and boiler house operation. Ideal for those who have little or no experience of steam – well we all have to start somewhere!

Courses

Introduction to Steam and Condensate Systems City & Guilds Assured
Steam Boiler Operation Fundamentals City & Guilds Accredited

[Find out more at spiraxsarco.com/global/en-GB/training](https://www.spiraxsarco.com/global/en-GB/training)

BOILER HOUSE OPERATOR

APPRENTICE

MAINTENANCE TECHNICIAN

SUPPORT FUNCTIONS



**SERVICE
ENGINEER**



ENGINEER

RELIABILITY ENGINEER

SYSTEMS DESIGN ENGINEER

PROJECT ENGINEER

BOILER INSPECTOR

MAINTENANCE ENGINEER

FACILITIES TECHNICIAN

OPERATION MANAGER

SITE MANAGER

Introduction to Steam and Condensate Systems

City & Guilds Assured

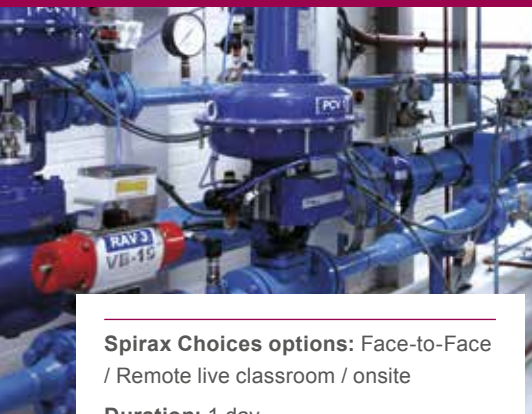

Spirax Choices options: Face-to-Face
/ Remote live classroom / onsite

Duration: 1 day

Course code: B1

For latest course date availability
please check our website.



ASSURED



Who is it for?

Anyone requiring an understanding of steam and condensate systems and factors affecting operation. Ideal for Apprentices, those new to a steam role in any capacity or anyone wanting a basic refresher.

What is it about?

This course provides a broad understanding of the purpose and safe operational requirements of steam and condensate systems.

On completion, delegates will receive a City & Guilds Assured certificate and digital credentials, there is no testing element on this course.

Course objectives

By the end of the course, delegates will be able to:

- » Understand the fundamentals of steam and its uses
- » Understand why condensate is formed, how and why it is removed and its value
- » Know the major components of a steam and condensate system
- » Understand how steam gets to the point of use
- » Understand the reasons for reducing pressure at the point of use

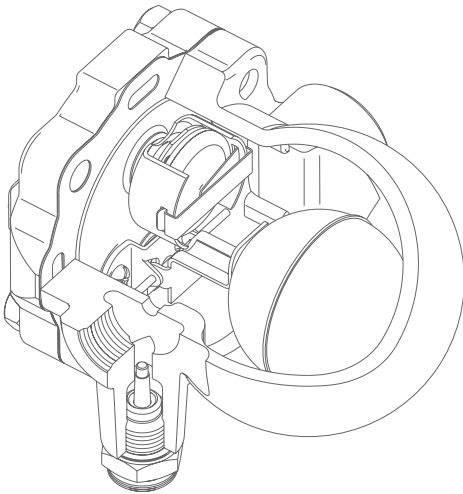

What our delegates said

“Gave me an insight into what steam is and how it is used.”

“Really good introduction to how the different components work and why they are needed.”

“Worked really well. The combination of slides, physical demos (objects), flipchart and video clips was brilliant. It really kept the engagement levels up.” (remote live classroom)

“A really fantastic training session, particularly as it had to be done remotely. Even after lockdown, I think this would work really well and may open up the training to a wider audience.” (remote live classroom)

Steam Boiler Operation Fundamentals (Shell Boiler) *City & Guilds Accredited*



Spirax Choices options: Face-to-Face
/ Blended learning option / onsite

Duration: 2 days (inc assessment) /
Course code: D6

**For latest course date availability
please check our website.**



Who is it for?

Anyone responsible for the day to day running of steam boilers - large and small and those involved in the planning or upgrading of boiler. It is also relevant for those needing an overview of how a boiler works or as a precursor to the BOAS course.

What is it about?

This practical course provides an understanding of the wet side of the boiler and outline trends in the management and control of boiler plant in order to achieve high levels of efficiency and safety with smooth operation. On completion, delegates will receive a City & Guilds Assured certificate and digital credentials, there is no testing element on this course.

Course objectives

By the end of the course delegates will be able to:

- » Identify major types of shell boiler
- » Understand the boiler fittings and their use
- » Know the types of daily/weekly tests recommended, including evaporation and water tests, including BG04
- » Understand elements of feedwater treatment, deaeration and storage
- » Understand boiler water level control and alarms
- » Understand blowdown controls, vessels and pits
- » Appreciate the benefits of heat recovery systems and energy efficiency fundamentals
- » Understand the requirements of efficient best practice including legislation and in particular BG01
- » Understand start up and shut down procedures
- » Understand how boilers produce steam and how this can affect other areas of the steam plant, including load

What our delegates said

“Really enjoyed learning on this course as it will help to improve my understanding on steam where I work.”



“Very useful information on how to work steam boilers.”

“I wanted a greater understanding of boiler operation of control, the course content and delivery was excellent, I’d highly recommend the course.”

“I would definitely recommend this course, it was excellent. It was informative and well put across - the trainer had great energy. I felt very involved and enjoyed learning from Tom who was a great teacher. Looking forward to coming back for my BOAS! Remote Attendee

“Very good course good for beginners with little experience on steam.”

BOILER HOUSE COURSES

Covering all aspects of boiler house operation, management, safety and efficiency from a fundamental level through to the BOAS accreditation.

Ensure your boiler house team are working safely and in line with the legislative requirements under regulation 9 of PUWER and point 6 of BG01.

Courses

Steam Boiler Operation Fundamentals City & Guilds Accredited
Boiler House Guidance, Regulations and Risk Assessment for Managers
Boiler House Water Treatment City & Guilds Accredited
Boiler Operation Accreditation Scheme (BOAS) Operator (Cert IBO)
Boiler Operation Accreditation Scheme (BOAS) Manager (Dip BOM)
Boiler Operation Accreditation Scheme (BOAS) 5 year Renewal

Find out more at spiraxsarco.com/global/en-GB/training

OPERATIONS MANAGER

BOILER HOUSE OPERATOR

BOILER HOUSE MANAGER

HEALTH & SAFETY ADVISER

APPOINTED PERSON

ENGINEERING MANAGER



APPOINTED ENGINEER

COMPETENT PERSON

ESTATES MANAGER

BOILER INSPECTOR

COMPLIANCE MANAGER

MAINTENANCE ENGINEER

FACILITIES TECHNICIAN

OPERATION MANAGER

ENGINEER SHIFT TECHNICIAN

MECHANICAL / ELECTRICAL ENGINEER

SITE MANAGER

ENGINEER

MANUFACTURING MANAGER

Steam Boiler Operation Fundamentals (Shell Boiler) *City & Guilds Accredited*

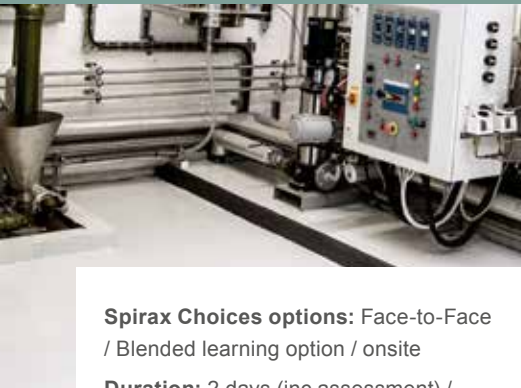

Spirax Choices options: Face-to-Face
/ Blended learning option / onsite

Duration: 2 days (inc assessment) /

Course code: D6

For latest course date availability
please check our website.



Who is it for?

Anyone responsible for the day to day running of steam boilers - large and small and those involved in the planning or upgrading of boiler. It is also relevant for those needing an overview of how a boiler works or as a precursor to the BOAS course.

What is it about?

This practical course provides an understanding of the wet side of the boiler and outline trends in the management and control of boiler plant in order to achieve high levels of efficiency and safety with smooth operation.

Course objectives

By the end of the course delegates will be able to:

- » Identify major types of shell boiler
- » Understand the boiler fittings and their use
- » Know the types of daily/weekly tests recommended, including evaporation and water tests, including BG04
- » Understand elements of feedwater treatment, deaeration and storage
- » Understand boiler water level control and alarms
- » Understand blowdown controls, vessels and pits
- » Appreciate the benefits of heat recovery systems and energy efficiency fundamentals
- » Understand the requirements of efficient best practice including legislation and in particular BG01
- » Understand start up and shut down procedures
- » Understand how boilers produce steam and how this can affect other areas of the steam plant, including load

What our delegates said

“Really enjoyed learning on this course as it will help to improve my understanding on steam where I work.”



“Very useful information on how to work steam boilers.”

“I wanted a greater understanding of boiler operation of control, the course content and delivery was excellent, I’d highly recommend the course.”

“I would definitely recommend this course, it was excellent. It was informative and well put across - the trainer had great energy. I felt very involved and enjoyed learning from Tom who was a great teacher. Looking forward to coming back for my BOAS!”
Remote Attendee

“Very good course good for beginners with little experience on steam.”



Boiler Operation Accreditation Scheme (BOAS) – Operator and Manager *(including 5 year Renewal)*

Spirax Choices options: Face-to-Face

Duration: 5 days (including assessment)

Course code: D6A / D6AR

For latest course date availability
please check our website.



Who is it for?

Designed for practicing boiler house operatives or those responsible for managing a boiler house and its operators.

What is it about?

The Boiler Operation Accreditation Scheme (BOAS) provides national certification for industrial boiler operators and managers. The BG01 guidelines suggest that all competent persons and owners/managers should be trained to the BOAS standard.

BOAS is based on legislation and best practices applicable within the UK and can only be delivered by licensed and approved training providers.

Spirax Sarco is a licensed and approved BOAS training provider and has been since the inception of BOAS.

Course objectives

This course provides preparation for undertaking the BOAS assessment covering all aspects of the required syllabus.

All awards are valid for five years, after which renewal becomes necessary².

The BOAS syllabus⁵ comprises learning outcomes in 10 sections as follows:

1. Safety & Legal
2. Fuel Concepts
3. Draught and combustion
4. Environment
5. Energy Efficiency
6. Basic Heat & heat transfer concepts (shell boilers)
7. Feed water & boiler water analysis (shell boilers)
8. Boilers & Auxiliaries (shell boilers)
9. Operation (shell boilers)
10. Control and instrumentation (shell boilers)

This course only covers cat 2 (shell boilers)

The assessment process

The course includes all elements of the assessment process for new and renewing candidates.

Both Operators and Managers need to complete the following:

1. Completion of mandatory evidence pack (different requirements for Operators and Managers)
2. Completion of series of written examinations¹

3. Interview with an assessor to establish the individual's knowledge and understanding, ability skills and experience⁴.

Pre-requisites

Essential

Boiler house operatives **MUST HAVE** a minimum of 6 months (100 hours) verified practical experience.

Supply of mandatory evidence pack to demonstrate the above (requirements will be supplied) applies to ALL awards and renewals.

Already BOAS qualified if a renewing candidate.

Recommended

Familiarisation with the BG01 guidelines.

Attendance on Steam Boiler Operation Fundamentals course – see page 32

Notes

The renewal option is for already accredited manager/supervisors and operators.

The course should be taken on the fifth anniversary of gaining the BOAS award and five yearly thereafter.

If you have completed BOAS with us before we will send you a reminder, otherwise please contact us before your renewal date. Courses can be taken up to 6 months ahead of expiry.

Refer to page 19 for info on how we support you.

¹ All candidates are required to sit examination papers regardless of award.

² A renewal course is necessary at five yearly intervals

³ Exact examination papers undertaken will vary depending on award.

⁴ Interview may be conducted on final day of course or on a pre-arranged date via remote platform depending on course choice

⁵ Syllabus may be subject to change

⁶ Set by Combustion Engineering Association and subject to change



Boiler house guidance, regulations and risk assessment for managers

Spirax Choices options: Face-to-Face

Duration: 1 day

Course code: RA1

For latest course date availability please check our website.

Who is it for?

Boiler house managers, Appointed Person, Appointed Engineer, competent person, individuals who need to conduct a specific boiler house risk assessment and anyone involved in the safe operation and assessment of a boiler house.

What is it about?

A practical course designed to provide an overview of the requirements of INDG436: Safe Management of industrial steam and hot water boilers and BG01 Guidance on the Safe Operation of Steam Boilers, how to conduct a risk assessment specific to the boiler house, the requirements of the legislation and a practical related activity using our boiler house.

Course objectives

By the end of the course delegates will be able to:

- » Understand the principles of risk assessment
- » Complete the risk assessment process
- » Know the definition of a competent person
- » Identify and know the requirements of INDG436 and associated legislation including BG01
- » Know the specific requirements for conducting a boiler house specific risk assessment



What our delegates said

“Given me confidence to now actually carry out a risk assessment.”

“Very informative and eye opening course gave me plenty to think about for writing our risk assessment.”

“The course was top class. Great course and fantastic trainer.”



Boiler House Water Treatment *City & Guilds Accredited*

Spirax Choices options: Face-to-Face
/ onsite

Duration: 1 day

Course code: W1

For latest course date availability
please check our website.



Who is it for?

Boiler house managers and operators involved in managing the water quality of their boilers.

What is it about?

This course is designed to explain why water treatment of steam plant helps to ensure it operates safely and efficiently. The aim is to provide delegates with the knowledge and information to help manage and treat the system effectively. It will also help with managing any third party water treatment contractors you use.

Course objectives

By the end of the course delegates will be able to:

- » Develop a practical guide to water treatment options
- » Understand the importance of water treatment guidelines, including BG04
- » Develop schemes to prevent scale, corrosion and fouling
- » Understand chemical dosing requirements
- » Know how to put in place a boiler water treatment strategy



What our delegates said

“Covered every aspect of everyday checks.”

“Very useful for Boiler House Managers.”

“From starting the day unclear of what is involved in maintaining a good water supply to the boiler, I now feel well informed.”

MAINTENANCE COURSES

Regular maintenance performed on your steam system will enable you to keep plant running, preventing potential downtime of production and ensuring individuals are working in a safe environment.

Our comprehensive maintenance training will provide methods for safely working on steam systems, help you reduce costs and improve the efficiency of your steam system.

Courses

Steam Plant Maintenance: City & Guilds accredited
Safety Valve Accreditation (Spirax Sarco valves only)

[Find out more at spiraxsarco.com/global/en-GB/training](https://www.spiraxsarco.com/global/en-GB/training)



MAINTENANCE TECHNICIAN
MAINTENANCE OPERATIVE

APPRENTICE
ESTATES MANAGER

**MULTI SKILLED
ENGINEER**

TECHNICIAN
ENGINEERING OFFICER

ESTATES ENGINEER
MAINTENANCE ENGINEER

ESTATES TEAM LEADER
MAINTENANCE MANAGER

FACILITIES SPECIALIST
MECHANICAL & CRAFT ENGINEER

MAINTENANCE FITTER

ENGINEER

SITE SERVICE ENGINEER



Steam Plant Maintenance *City & Guilds Accredited*

Spirax Choices options: Face-to-Face

Duration: 4 days

Course code: M2

For latest course date availability
please check our website.



Who is it for?

Those involved with the maintenance and installation of steam systems and those wishing to obtain a recognised maintenance based steam accreditation.

What is it about?

This course provides delegates with the basic knowledge and practical skills necessary to identify faults and maintain steam systems. Delegate's competence and knowledge will be assessed based on a City & Guilds approved syllabus.

Course objectives

By the end of the course, delegates will be able to:

- » Understand the fundamentals of steam systems
- » Demonstrate good installation practices
- » Demonstrate fault finding through practical experience
- » Maintain steam traps, pressure reducing valves and other ancillary equipment
- » Have an understanding of basic elements in the boiler house

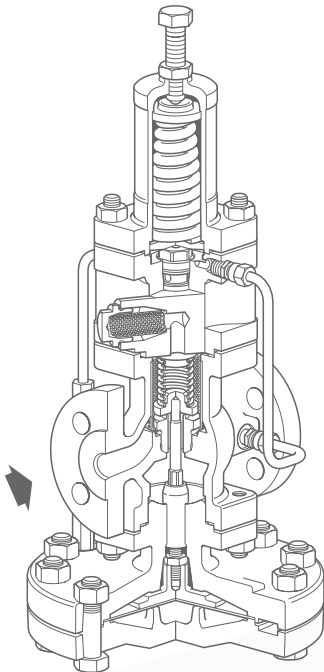

What our delegates said

“Very good course one of the best courses and instructors I have had, course was perfect.”

“Extremely helpful for my job. Above & beyond what I expected.”

“Great course, well delivered by very good trainers, very good and thorough course & content.”

“Excellent, well informed course thank you.”

“Excellent, course provided a great balance between steam theory & practical applications.”

“I have enjoyed the course and gained knowledge to help me with my job by far the best course I have been on.”



Safety Valve Accreditation

Spirax Choices options: Face-to-Face

Duration: 1 day

Course code: M3

For latest course date availability please check our website.

Who is it for?

Those involved with the installation, maintenance and setting of Spirax Sarco safety valves and requiring training to work on them.

What is it about?

This course gives an understanding of the importance of safety valves, their sizing, setting and installation and what work may be carried out on them, all in accordance with current legislation.

Course objectives

By the end of the course, delegates will be able to:

- » Know the purpose of safety valves
- » Understand the selection of set pressure
- » Be able to identify factors affecting sizing
- » Know the main issues around safety valve installation
- » Know the key parts for installation of safety valves
- » Understand what maintenance is permissible and how to carry this out safely

Additional Information

This course only applies to Spirax Sarco safety valves.



What our delegates said

“Was perfect for increasing understanding of safety valves and where they are needed.”

“Exactly what was required, in-depth & interesting taught me a lot, practical was to the point & showed me exactly what we needed to do.”

“Brilliant training course as always.”

SPECIALIST COURSES

A suite of specialist courses covering key topics in the steam and thermal energy industry aimed at helping you to improve efficiency and cost savings.

Courses

Design of Steam and Condensate Systems City & Guilds Accredited
Steam Quality Testing City & Guilds Accredited

[Find out more at spiraxsarco.com/global/en-GB/training](https://spiraxsarco.com/global/en-GB/training)

ENGINEERING PROJECTS MANAGER
ENGINEER

SENIOR MECHANICAL ENGINEER

MECHANICAL DESIGN
ENGINEER

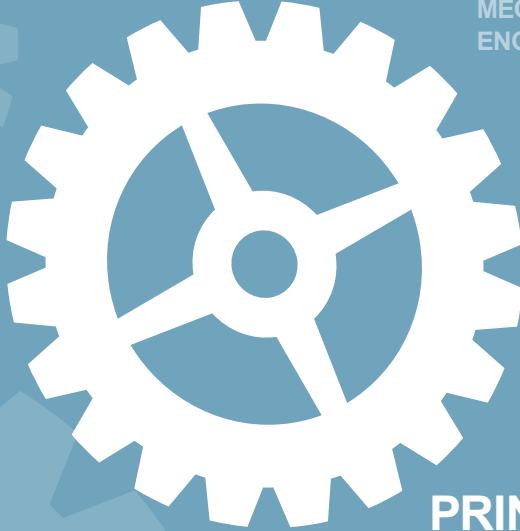

**PRINCIPAL
MECHANICAL
ENGINEER**

BUILDING SERVICES ENGINEER
DESIGN & DEVELOPMENT ENGINEER

SERVICES LEAD ENGINEER

ENGINEERING PLANNER

PROJECT ENGINEER

PROCESS ENGINEER

HEAD OF MECHANICAL



Steam Quality Testing *City & Guilds Accredited*

Spirax Choices options:

Face-to-Face / Remote

Duration: 2 days

Course code: SQT

For latest course date availability
please check our website.



ACCREDITED

Who is it for?

Individuals who are required to conduct steam quality tests to BS EN 285 standards. This will include pharmaceutical, healthcare and food and beverage sites.

What is it about?

This City & Guilds accredited practical course will enable you to undertake steam quality testing in line with BS EN 285 standards.

Course objectives

- » Understand the fundamentals of steam systems
- » Understand the different grades of steam
- » Define the attributes of steam quality and why they are important
- » Define the difference between steam quality and steam purity
- » Understand the importance of an 4 main types of Steam Quality tests and how this relates to legislation
- » Demonstrate competence in the use of the Steam Quality Testing kit
- » Identify and know the main requirements of all relevant legislation (inc BS EN 285)
- » Understand micro biology relevant to sterilisation
- » Explain the application and operating principle of steam sterilisers
- » Explain contributory factors to and causes of poor steam quality

Notes

Renewal every 3 years recommended

What our delegates said

“Very informative, well structured.”

“Really interesting and engaging”

“Excellent course, excellent transfer of knowledge.”

“The course is fun & enjoyable.”

Design of Steam and Condensate Systems

City & Guilds Accredited

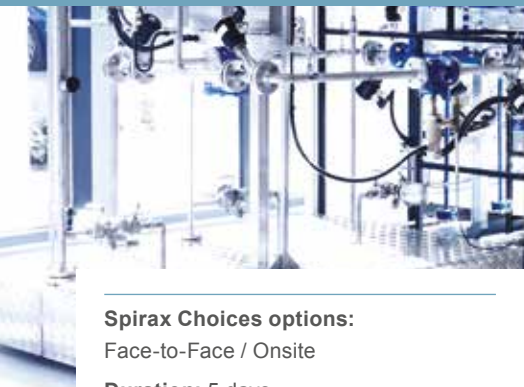

Spirax Choices options:

Face-to-Face / Onsite

Duration: 5 days

Course code: D1

For latest course date availability
please check our website.



ACCREDITED



Who is it for?

Designers, consultants, plant engineers, and those responsible for the general design and layout of steam and condensate services.

What is it about?

This project based course provides specialist knowledge of current practices in steam and condensate systems, and the factors to be considered in their design.

Course objectives

By the end of the course delegates will be able to:

- » Understand the properties of steam and why it is used
- » Calculate the steam demand for different types of steam plant
- » Understand the requirements of steam distribution system
- » Understand the need for different steam traps and air vents
- » Understand the different methods of steam trap checking and their advantages and disadvantages
- » Explain the requirement to remove and recover condensate
- » Understand the need for pressure reduction and the different types available
- » Explain the factors affecting control valves
- » Realise the importance of flash steam recovery
- » Explain how safety valves are set, lift and leak
- » Size pressure reducing valves, steam pipe, condensate pipe, control valves, steam traps, condensate pumps, flash vessels, safety valves and blowdown vessel

Pre-requisites

A good level of technical knowledge is recommended.



What our delegates said

“Exactly what I wanted, a very necessary course if you are working with steam.”

“Great experience given the delivery method. Very engaging trainers and great energy from both trainers. The two trainers worked amazing as a team in the manner of delivery.” (remote live classroom)

“This has been very useful and given me great confidence to size steam systems and understand the theory.”

“It gave a brilliant overview of steam and condensate design and was very well presented.”



Specialist and Bespoke Training >

**Need something a little
more specific?
A little more technical?**



Our team is passionate about steam, which means we can also help on a range of other topics, training areas and bespoke courses that may not need addressing on such a regular basis. For example, Safe Isolation of Plant.

Contact us to chat through your requirements and we will put together a suitable proposal and costings. Bespoke and specialist courses can be delivered through our Spirax Choices offer, subject to minimum numbers and subject to trainer availability.





Building the case for investing in training >

Training should always be considered an investment but sometimes requesting the funds for your plans is not always straight forward. So to help you secure your budget, here are the key reasons for investing in training. You can find more detailed information on spiraxsarco.com/global/en-GB/training



**IMPROVES STAFF
RETENTION AND
MOTIVATION**



**PROVIDES THE
KNOWLEDGE FOR YOU
AND YOUR TEAM TO WORK
SAFELY AND SUSTAINABLY**



**INCREASES
PRODUCTIVITY**



**ALLOWS YOU AND THE
TEAM TO KEEP UP TO
DATE WITH LEGISLATION
AND BEST PRACTICE**



**UPSILLS YOUR
WORKFORCE TO CREATE A
DIVERSE SKILL SET**



**PROMOTES HIGHER
LEVELS OF CUSTOMER
SATISFACTION**



**SPECIFIC JOB
REQUIREMENT E.G. BOILER
OPERATORS AND BOAS**



**INCREASES
YOUR COMPETITIVE
ADVANTAGE**



**YOU CAN ATTRACT THE
BEST TALENT IN THE
MARKETPLACE**

And if that hasn't persuaded you then consider this quote by the late American author and motivational speaker, Zig Ziglar >

“

The only thing worse than training an employee and having them leave, is to not train them, and have them stay.

”



How to book

Book online at spiraxsarco.com/global/en-GB/training

Call us on 01242 535211 for course information and availability.

Email us at training@uk.spiraxsarco.com

Please note that prices quoted are per person. Your booking can only be confirmed once we have received your completed registration form and a copy of your purchase order.

Where to stay

Our courses do not include accommodation but we will send through an up to date list of places to stay during your course with your booking confirmation. This information is also available on our website.

We have negotiated special rates if you mention us. We monitor the feedback from other delegates to refine the providers.

Catering

Courses running at our training centre include refreshments and lunch from our on-site Bistro.

Cancellation policy

Please see our website for the latest full cancellation terms and conditions.



Please note we reserve the right to cancel any course date due to a shortage of delegates or unforeseen circumstances. We will provide as much notice as possible but in exceptional circumstances this may not always be possible. We recommend that any hotel and travel bookings are made on a flexible basis.

Pricing

Correct at time of publishing. Check website for current listings. Examination and assessment fees may be subject to change.

Get in touch

We'd love to hear from you and we can be contacted as follows:

 01242 535211

 training@uk.spiraxsarco.com

 [spiraxsarco.com/global/en-GB/training](https://www.spiraxsarco.com/global/en-GB/training)

 Spirax Sarco UK and Ireland

 @Spirax_Sarco_UK

 SpiraxSarcoUK

Spirax Sarco | UK Steam Technology Centre
| Charlton House | Cirencester Road |
Cheltenham | Gloucestershire | GL53 8ER

You're in good company >

Here is a small selection of the organisations that we have supported to deliver their training requirements:

Acetate Products

Allianz Engineering

Allied Bakeries

AstraZeneca

AWE

Britvic

CBRE

Coca-Cola

Corus Strip Products

Del Monte Foods

Ford Motor Company, Dagenham

GlaxoSmithKline

Imperial Tobacco

Kohler Mira

Mars

Masterfoods

Medical Research Council

Nestlé

Northumbrian Water

Palace of Westminster

Pfizer

Rank Hovis

Rolls-Royce Power Engineering

Roxel UK Rocket Motors

Royal Holloway University of London

Royal Sun Alliance

Severn Trent Water

Smith & Nephew

St George's Hospital, London

St Joseph's Hospital, Newport

The Wrigley Company

Unilever Bestfoods

Unilever UK Foods

United Utilities

Wyeth Labs





PHOTO DISCLAIMER:
Some photos may have
been taken prior to
social distancing.

spirax
sarco

UK Steam Technology Centre
Spirax-Sarco Limited, Charlton House,
Cheltenham, Gloucestershire, GL53 8ER, UK

T +44 (0)1242 535211

F +44 (0)1242 535578

E training@uk.spiraxsarco.com

sxscom.uk/training



UK-STC25-UK-ISS1

© Copyright 2024 Spirax Sarco is a registered trademark of Spirax-Sarco Limited.
Some products, services or solutions may not be available in certain markets.

202497299