

UTD26 and UTD26Y
Thermodynamic Steam Traps
Installation and Maintenance Instructions

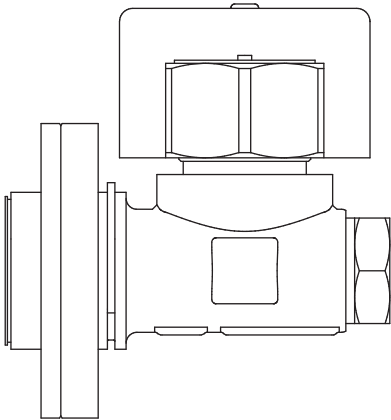

1. Safety information
2. General product information
3. Installation
4. Commissioning
5. Operation
6. Maintenance
7. Spare parts

1. Safety information

Safe operation of these products can only be guaranteed if they are properly installed, commissioned, used and maintained by qualified personnel (see Section 1.11) in compliance with the operating instructions. General installation and safety instructions for pipeline and plant construction, as well as the proper use of tools and safety equipment must also be complied with.

1.1 Intended use

Referring to the Installation and Maintenance Instructions, name-plate and Technical Information Sheet, check that the product is suitable for the intended use/application. These products comply with the requirements of the EU Pressure Equipment Directive (PED), and the UK Pressure Equipment (Safety) Regulations (PER) and all fall within category 'SEP'. It should be noted that products within this category are required by the Directive not to carry the  mark.

- i) These products have been specifically designed for use on steam, air or condensate/water, which is in Group 2 of the above mentioned Pressure Equipment Directive. The products' use on other fluids may be possible but, if this is contemplated, Spirax Sarco should be contacted to confirm the suitability of the product for the application being considered.
- ii) Check material suitability, pressure and temperature and their maximum and minimum values. If the maximum operating limits of the product are lower than those of the system in which it is being fitted, or if malfunction of the product could result in a dangerous overpressure or overtemperature occurrence, ensure a safety device is included in the system to prevent such over-limit situations.
- iii) Determine the correct installation situation and direction of fluid flow.
- iv) Spirax Sarco products are not intended to withstand external stresses that may be induced by any system to which they are fitted. It is the responsibility of the installer to consider these stresses and take adequate precautions to minimise them.
- v) Remove protection covers from all connections and protective film from all name-plates, where appropriate, before installation on steam or other high temperature applications.

1.2 Access

Ensure safe access and if necessary a safe working platform (suitably guarded) before attempting to work on the product. Arrange suitable lifting gear if required.

1.3 Lighting

Ensure adequate lighting, particularly where detailed or intricate work is required.

1.4 Hazardous liquids or gases in the pipeline

Consider what is in the pipeline or what may have been in the pipeline at some previous time. Consider: flammable materials, substances hazardous to health, extremes of temperature.

1.5 Hazardous environment around the product

Consider: explosion risk areas, lack of oxygen (e.g. tanks, pits), dangerous gases, extremes of temperature, hot surfaces, fire hazard (e.g. during welding), excessive noise, moving machinery.

1.6 The system

Consider the effect on the complete system of the work proposed. Will any proposed action (e.g. closing isolation valves, electrical isolation) put any other part of the system or any personnel at risk?

Dangers might include isolation of vents or protective devices or the rendering ineffective of controls or alarms. Ensure isolation valves are turned on and off in a gradual way to avoid system shocks.

1.7 Pressure systems

Ensure that any pressure is isolated and safely vented to atmospheric pressure. Consider double isolation (double block and bleed) and the locking or labelling of closed valves. Do not assume that the system has depressurised even when the pressure gauge indicates zero.

1.8 Temperature

Allow time for temperature to normalise after isolation to avoid danger of burns.

1.9 Tools and consumables

Before starting work ensure that you have suitable tools and/or consumables available. Use only genuine Spirax Sarco replacement parts.

1.10 Protective clothing

Consider whether you and/or others in the vicinity require any protective clothing to protect against the hazards of, for example, chemicals, high/low temperature, radiation, noise, falling objects, and dangers to eyes and face.

1.11 Permits to work

All work must be carried out or be supervised by a suitably competent person. Installation and operating personnel should be trained in the correct use of the product according to the Installation and Maintenance Instructions.

Where a formal 'permit to work' system is in force it must be complied with. Where there is no such system, it is recommended that a responsible person should know what work is going on and, where necessary, arrange to have an assistant whose primary responsibility is safety.

Post 'warning notices' if necessary.

1.12 Handling

Manual handling of large and/or heavy products may present a risk of injury. Lifting, pushing, pulling, carrying or supporting a load by bodily force can cause injury particularly to the back. You are advised to assess the risks taking into account the task, the individual, the load and the working environment and use the appropriate handling method depending on the circumstances of the work being done.

1.13 Residual hazards

In normal use the external surface of the product may be very hot. If used at the maximum permitted operating conditions the surface temperature of some products may reach temperatures of 500 °C (932 °F).

Many products are not self-draining. Take due care when dismantling or removing the product from an installation (refer to 'Maintenance instructions').

1.14 Freezing

Provision must be made to protect products which are not self-draining against frost damage in environments where they may be exposed to temperatures below freezing point.

1.15 Disposal

Unless otherwise stated in the Installation and Maintenance Instructions, this product is recyclable and no ecological hazard is anticipated with its disposal providing due care is taken.

1.16 Returning products

Customers and stockists are reminded that under EC Health, Safety and Environment Law, when returning products to Spirax Sarco they must provide information on any hazards and the precautions to be taken due to contamination residues or mechanical damage which may present a health, safety or environmental risk. This information must be provided in writing including Health and Safety data sheets relating to any substances identified as hazardous or potentially hazardous.

2. General product information

2.1 General description

All bodies for both series of traps have an electroless nickel preparation finish (ENP) which is both energy efficient and corrosion resistant. All traps are fitted by two screws to a permanently installed stainless steel pipeline connector to ensure the maintenance is both quick and easily undertaken. Traps can be removed/replaced using a simple wrench with minimum system downtime.

UTD26 series

The UTD26 series are a stainless steel thermodynamic steam trap available with and without integral strainer. They are attached to a suitable pipeline connector by two bolts for quick and easy replacement.

The UTD26 does not have an integral strainer and requires a strainer to be installed upstream of the trap. The UTD26Y has an integral strainer. An integral blowdown valve can be fitted to the UTD26Y for screen blowdown (see Optional extras).

Available types of UTD26Y with integral strainer

UTD26LY	Low capacity for mains drainage and tracing applications.
UTD26HY	For higher capacity applications.
UTD26LAY	Low capacity for mains drainage and tracing applications plus anti-air-binding disc.
UTD26HAY	For higher capacity applications plus anti-air-binding disc.

Available types of UTD26 without integral strainer

UTD26L	Low capacity for mains drainage and tracing applications.
UTD26H	For higher capacity applications.
UTD26LA	Low capacity for mains drainage and tracing applications plus anti-air-binding disc.
UTD26HA	For higher capacity applications plus anti-air-binding disc.

Note: Spirax Sarco recommend that UTD26 without strainer variants only be installed on a pipeline connector with integral strainer or when a y-type strainer is installed upstream of the trap.

Optional extras

Insulating cover: To protect the trap operation from the effects of wind, rain and low temperatures. Fitting this cover will increase the operational life of the trap under these conditions.

Integral blowdown valve: A blowdown valve can be fitted by replacing the strainer cap with a blowdown valve adaptor. Having a blowdown valve fitted will aid the removal of debris from the inside of the strainer screen. This should be carried out periodically depending on the cleanliness of the system.

Standards

These products fully comply with the requirements of the EU Pressure Equipment Directive (PED), the UK Pressure Equipment (Safety) Regulations (PER) and are fully ASME compliant.

Certification

These products are available with certification to EN 10204 3.1.

Note: All certification/inspection requirements must be stated at the time of order placement.

Note: For additional information see TI-P154-04.

2.2 Sizes and pipe connections

The UTD26 and UTD26Y can be fitted to a variety of different pipeline connectors which include:-

PC10HP	Straight connector	ANSI/ASME 600	(see TI-P128-10)
PC20	Connector with Y-type strainer	ANSI/ASME 300	(see TI-P128-15)
PC3_	Connector with one piston isolation valve	ANSI/ASME 600	(see TI-P128-34)
PC4_	Connector with two piston isolation valves	ANSI/ASME 600	(see TI-P128-33)
STS17.2	Steam Trapping Station	PN40	(see TI-P128-22)

Note: Spirax Sarco recommend that UTD26 without strainer variants only be installed on a pipeline connector with integral strainer or when a y-type strainer is installed upstream of the trap.

See the relevant Technical Information Sheet as listed above for details of the connections available on pipeline connectors.

UTD26LA, UTD26HA, UTD26LAY and UTD26HAY
Anti-air-binding disc (optional)

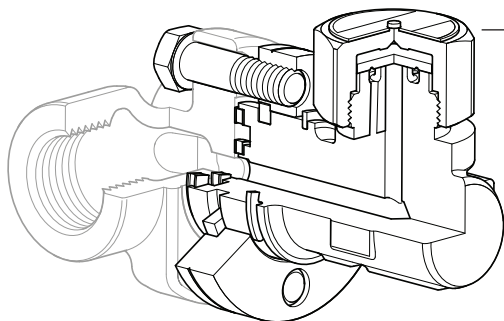

Fig.1 UTD26L and UTD26H shown fitted to a PC10HP connector

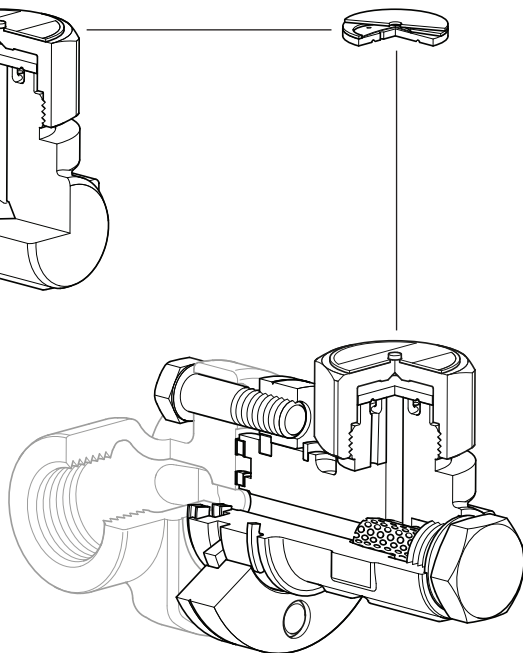
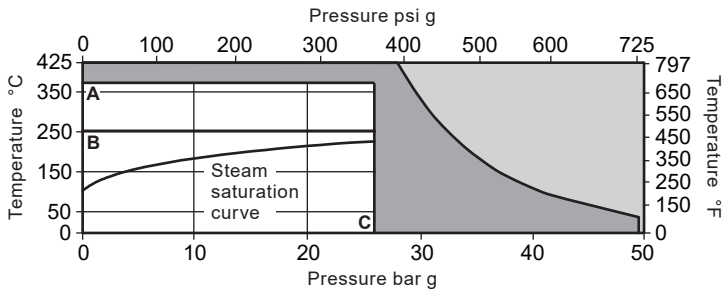

Fig.2 UTD26LY and UTD26HY shown fitted to a PC10HP connector

2.3 Pressure/temperature limits (ISO 6552)



The product **must not** be used in this region.

The product **must not** be used in this region.

A - C UTD26LY and UTD26HY, UTD26L and UTD26H

B - C UTD26LAY and UTD26HAY, UTD26LA and UTD26HA

Note: The model of pipeline connector and connection selected will dictate the maximum operating limits of the complete assembly. Reference the specific pipeline connector Technical Information sheet as detailed in 'Pipeline connector options'.

Body design conditions		ASME B16.34 Class 300	
PMA	Maximum allowable pressure	49.6 bar g @ 38°C (719 psi g @ 100 °F)	
TMA	Maximum allowable temperature	425°C @ 28 bar g (797 °F @ 406 psi g)	
Minimum allowable temperature		0 °C (32 °F)	
PMO	Maximum operating pressure for saturated steam service	26 bar g (377 psi g)	
TMO	Maximum operating temperature	UTD26L and UTD26H, UTD26LY and UTD26HY	370°C @ 26 bar g (698 °F @ 377 psi g)
		UTD26LA and UTD26HA, UTD26LAY and UTD26HAY	255°C @ 26 bar g (491 °F @ 377 psi g)
Minimum operating temperature		0 °C (32 °F)	
ΔPMX	Maximum differential pressure	26 bar g (377 psi g)	
PMOB	Maximum operating backpressure should not exceed 80% of the upstream pressure		
Minimum inlet pressure for satisfactory operation		0.25 bar g (3.6 psi g)	
Designed for a maximum cold hydraulic test pressure of:		75 bar g (1087.7 psi g)	

UTD26 and UTD26Y Thermodynamic Steam Traps

3. Installation

Note: Before actioning any installation observe the 'Safety information' in Section 1.

Referring to the Installation and Maintenance Instructions, name-plate and Technical Information Sheet, check that the product is suitable for the intended installation:

- 3.1** Check materials, pressure and temperature and their maximum values. If the maximum operating limit of the product is lower than that of the system in which it is being fitted, ensure that a safety device is included in the system to prevent overpressurisation.
- 3.2** Determine the correct installation situation and the direction of fluid flow.
- 3.3** Remove protective covers from all connections and protective film from all name-plates, where appropriate, before installation on steam or other high temperature applications.
- 3.4** The UTD26 and UTD26Y can be installed on any pipeline connector, but must be installed in a horizontal plane with the top cap uppermost. See separate Installation and Maintenance Instructions for Spirax Sarco pipeline connectors (IM-P128-06, IM-P128-11 and IM-P128-13).

Ensure that both gaskets are clean and undamaged and that the transfer holes are clear. Place the trap body against the connector gasket face, ensuring that the top cap is uppermost and the trap itself is horizontal.

Apply a small amount of anti-seize compound to the threads of the connector screws (13). Tighten the screws finger tight until the mating gasket faces are in parallel, intimate contact. Tighten the screws to the recommended torque value (see Table 1, page 12). Open isolation valves slowly until normal operating conditions are achieved.

- 3.5** Check for leaks.
- 3.6** If the trap is to discharge to atmosphere ensure it is to a safe place, the discharging fluid may be at a temperature of 100 °C (212 °F).

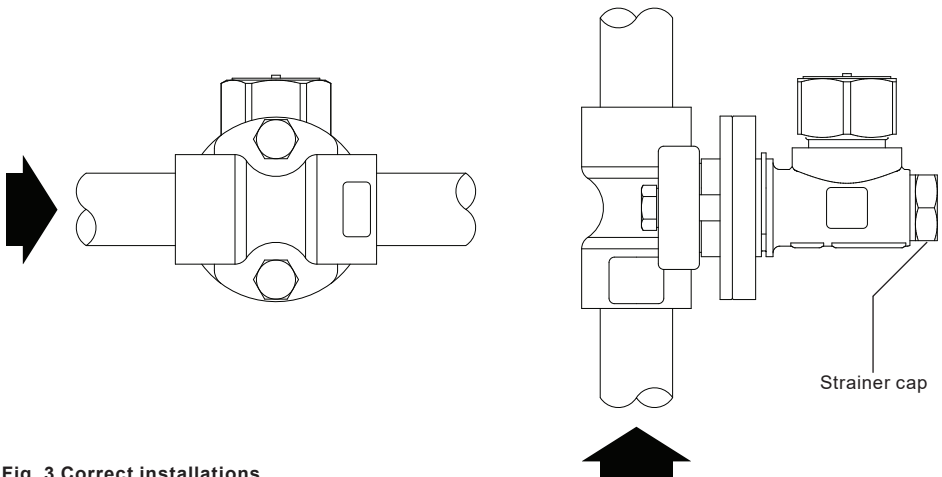

Fig. 3 Correct installations

4. Commissioning

After installation or maintenance ensure that the system is fully functioning. Carry out tests on any alarms or protective devices.

5. Operation

The UTD26 and UTD26Y are thermodynamic steam traps that use a disc to control the release of condensate and to trap steam. The trap cycles open and closed to discharge condensate close to steam temperature and closes tight between discharges. The disc, which is the only moving part, rises and falls in response to dynamic forces produced by the partial re-evaporation (flashing) of hot condensate. Cool condensate, air and other non-condensable gases enter the trap through the central orifice, lift the disc, and are discharged through the outlet orifice. When the condensate approaches steam temperature, a portion of it flashes as it enters the trap. The flash steam passes at high velocity over the underside of the disc and collects in the control chamber above. The resulting pressure imbalance forces the disc downward onto the seating surfaces, stopping the flow. The trap remains tightly closed until the loss of heat through the trap body lowers the control chamber pressure, allowing the inlet pressure to raise the disc and repeat the cycle. An insulating cover prevents the trap being unduly influenced by excessive heat loss when subjected to low ambient temperatures, wind, rain, etc.

6. Maintenance

Note: Before actioning any maintenance programme observe the 'Safety information' in Section 1.

Warning

The inner and outer gaskets used when installing / maintaining the UTD26 and UTD26Y to a PC₋ pipeline connector contain thin stainless steel support rings which may cause physical injury if not handled and disposed of carefully.

6.1 General information

Before undertaking any maintenance on the trap it must be isolated from both the supply line and return line and any pressure allowed to safely normalise to atmosphere. The trap should then be allowed to cool. When reassembling, ensure that all joint faces are clean.

6.2 Replacement of the trap unit:

- Ensure that the correct tools and necessary protective equipment are used at all times.
- Replacement of the trap unit is achieved by removing the two connector screws (13) and removing the trap.
- The new trap unit should be positioned against the connector gasket face and apply a small amount of anti-seize compound to the threads of the connector screws.
- Tighten screws finger tight and ensure that the trap body is parallel to the connector.
- Tighten the screws to the recommended torque (see Table 1, page 12).
- Open isolation valves slowly until normal operating conditions are achieved.
- Check for leaks.

6.3 How to repair or replace the disc/seat:

- Remove the insulating cover (14) if fitted and unscrew the cap (2) using a suitable socket or spanner. Do not use Stillsons or a wrench of a similar type which may cause distortion of the cap.
- If the disc (3) and body seating faces are only slightly worn, they can be refaced by lapping individually on a flat surface such as a surface plate. A figure-of-eight motion and a little lapping compound give the best results.
If the wear is too great to be rectified by simple lapping, the seating faces on the body must be ground flat and then lapped. The total amount of metal removed in this way should not exceed 0.25 mm (0.010"). The disc (3) should then be renewed.
- When reassembling, the disc (3) is normally placed with the grooved side in contact with the seating faces. The screw-on cap does not require a gasket, but a suitable high temperature anti-seize grease should be applied to the threads. Tighten to the recommended torque (see Table 1, page 12).
- Open isolation valves slowly until normal operating conditions are achieved.
- Check for leaks.

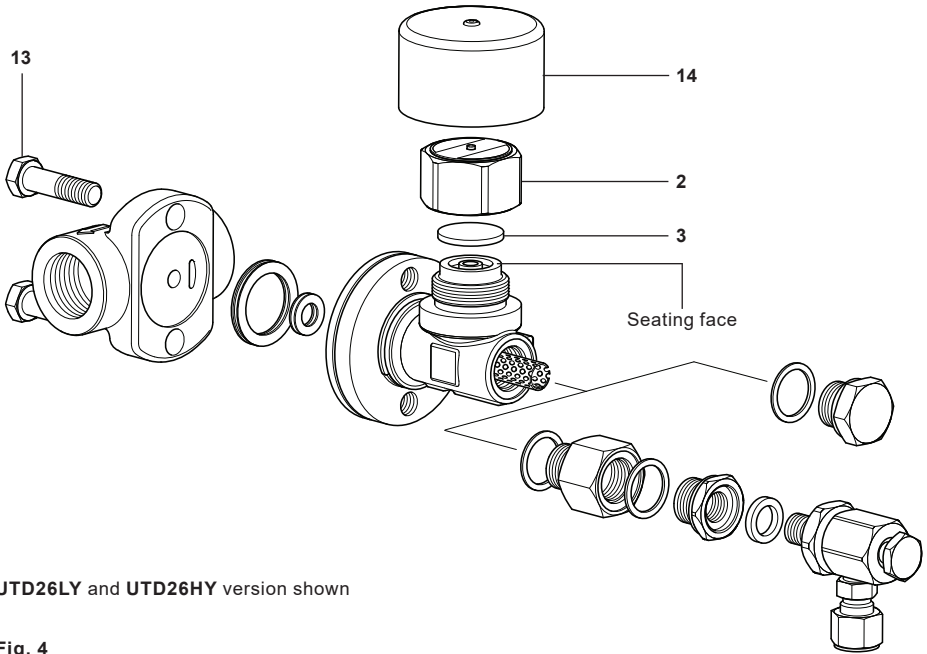

6.4 How to clean or replace the strainer screen



UTD26Y:

- Unscrew the strainer cap (6) using a spanner.
- Withdraw the screen (4) and clean, or if damaged replace with a new one.
- Remove the old gasket (5), clean the gasket faces, and replace with a new one.
- To reassemble, insert the screen (5) into the cap (6), then screw the cap into place.
Note: A fine smear of 'Molybdenum Disulphide' grease should be applied to the first few threads. Care should be taken to ensure that the gasket and gasket faces are clean. Tighten the cap (6) to the recommended torque (see Table 1).
- Open isolation valves slowly until normal operating conditions are achieved.
- Check for leaks.

UTD26Y + integral blowdown valve:

- Unscrew the adapter (23) using a spanner.
- Withdraw the screen (4) and clean, or if damaged replace with a new one.
- Remove the old gasket (5), clean the gasket faces, and replace with a new one.
- To reassemble, insert the screen (5) into the adapter (23), then screw the adapter into place. Note: A fine smear of 'Molybdenum Disulphide' grease should be applied to the first few threads. Care should be taken to ensure that the gasket and gasket faces are clean. Tighten the adapter (23) to the recommended torque (see Table 1).
- Open isolation valve slowly until normal operating conditions are achieved.
- Check for leaks.

Table 1 Recommended tightening torques

Item	Part	 or  mm	N m	(lbf ft)
2	LY and LAY, L and LA HY and HAY, H and HA	36 A/F	135 – 150	99 - 110
		41 A/F	180 – 200	133 - 148
6		24 A/F M18	75 – 80	55 - 59
13		3/16" A/F	33	24.3
20		27 A/F	45 – 50	33 - 37
22		24 A/F M18	75 – 80	55 – 59
23		27 A/F M18	75 – 80	55 - 59

Note: The blowdown valve screw on the integral blowdown valve (see Figure 6) should be tightened to 22 - 25 N m (16 - 17 lbf ft).

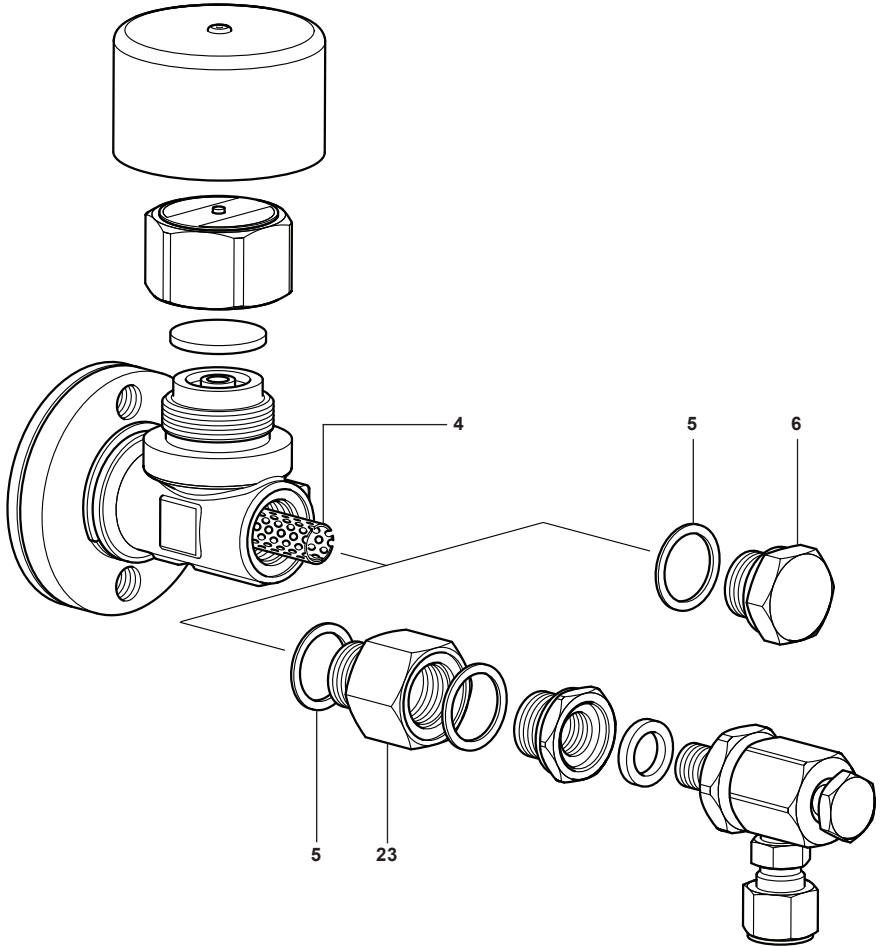

UTD26LY and UTD26HY version shown

Fig. 5

6.5 Blowdown valve maintenance and line positioning

How to adjust the outlet position

- To set the position of the blowdown valve outlet, unscrew the locknut (20), turn the blowdown valve assembly (15) clockwise until the threads are fully engaged, then rotate it anti-clockwise 0 - 360 degrees to determine the outlet position. Tighten the locknut (20) by turning it clockwise and torque to 45-50Nm to lock the blowdown valve assembly in position.
- If leakage occurs through the blowdown valve gland packing (21), tighten the locknut (20). If leakage persists, replace the gland packing.

How to replace the gland packing

- Loosen the locknut (20) by turning it anti-clockwise using a spanner.
- Unscrew the blowdown valve assembly (15) from the bottom body (22).
- Remove the gland packing (21) from the bottom body (22), clean the sealing faces, and replace with a new one.
- To reassemble, screw in the blowdown valve assembly (15) until the threads are fully engaged, taking care not to damage the gland packing (21), then rotate it anti-clockwise 0 - 360 degrees to determine the outlet position. Tighten the locknut (20) by turning it clockwise and torque to 45-50Nm to lock the blowdown valve assembly in position.

How to replace the gasket

- Loosen the locknut (20) by turning it anti-clockwise using a spanner.
- Unscrew the bottom body (22) using a spanner.
- Remove the old gasket (5), clean the gasket faces, and replace with a new one.
- To reassemble, screw the bottom body (22) into place. Note: A fine smear of 'Molybdenum Disulphide' grease should be applied to the first few threads. Care should be taken to ensure that the gasket and gasket faces are clean. Tighten the bottom body (22) to the recommended torque (see Table 1, page 12).
- Turn the blowdown valve assembly (15) clockwise until the threads are fully engaged, then rotate it anti-clockwise 0 - 360 degrees to determine the outlet position. Tighten the locknut (20) by turning it clockwise and torque to 45-50Nm to lock the blowdown valve assembly in position.
- If leakage occurs through the gasket (5) between the body (1) and adapter (23), tighten the adapter. If leakage persists, replace the gasket.

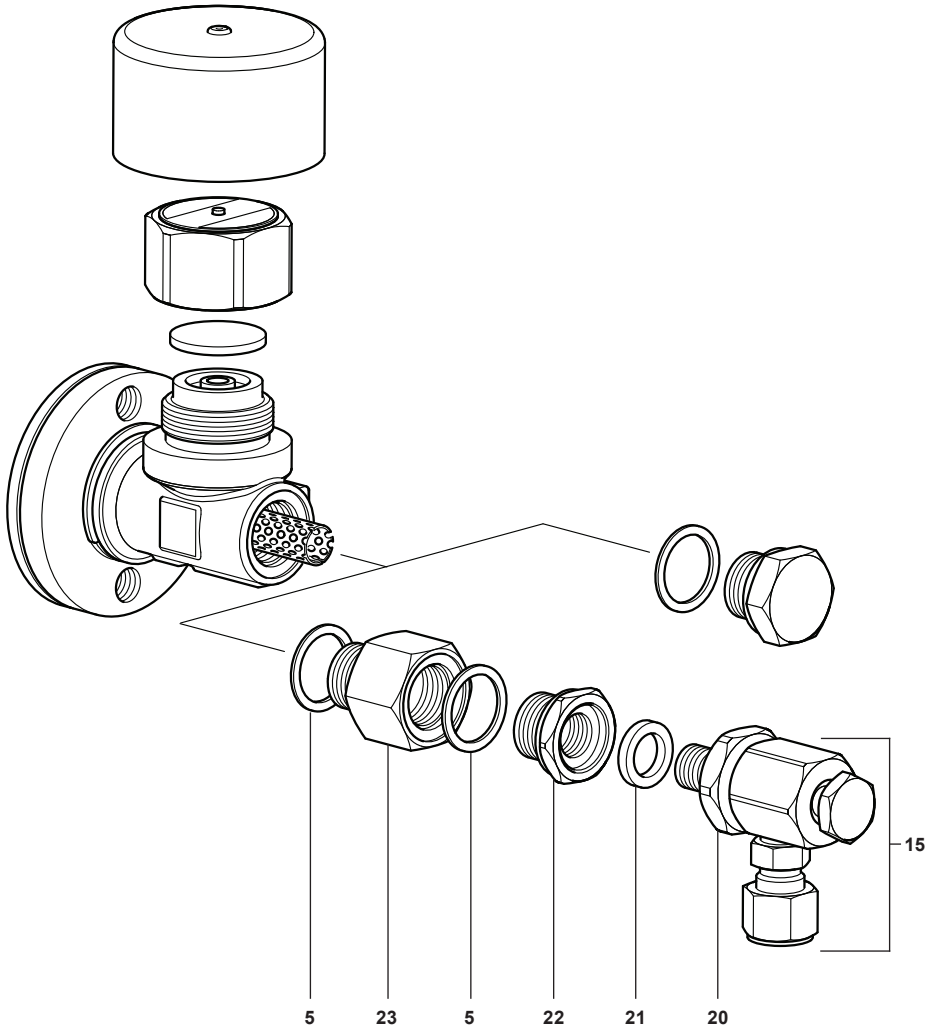

UTD26LY and UTD26HY version shown

Fig. 6

7. Spare parts

The spare parts available are shown in solid outline. Parts drawn in a grey line are not supplied as spares.

Available spares

Inner and outer gasket set (pack of 3)		10, 11
Connector screws and inner and outer gasket set		10, 11, 13
Disc (pack of 3)	UTD26LY and UTD26HY, UTD26L and UTD26H	3
Disc, strainer screen, and strainer cap gasket	UTD26LAY and UTD26HAY, UTD26LA and UTD26HA	3, 4, 5
Strainer cap gasket (pack of 10)	UTD26_Y	5
Strainer screen and strainer cap gasket (pack of 3 each)	UTD26_Y	4, 5
Gland packing (pack of 3)	Blowdown valve	21
Insulating cover		14

Always order spare parts by using the description given in the column headed 'Available spares' and state the size and type of trap.

Example 1: Packet of 3 discs for a Spirax Sarco UTD26LAY steam trap.

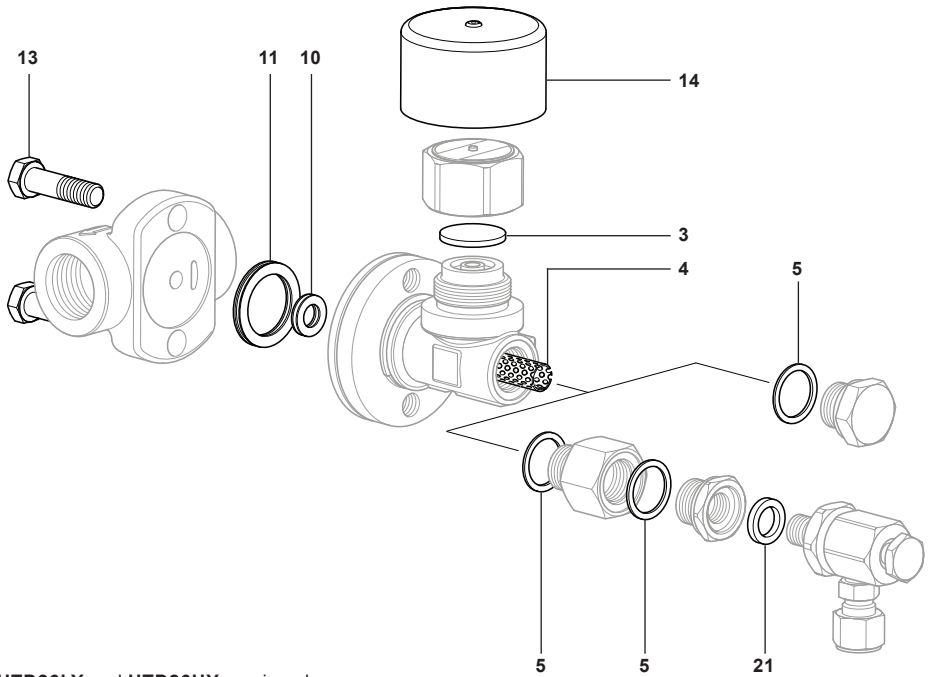

UTD26LY and UTD26HY version shown

Fig. 7

