



## QLM and QLD Series Three-port Control Valves

### Description

The QLM and QLD are three-port control valves which have linear characteristics for mixing or diverting service. These valves can be used on thermal oil, compressed air, steam, condensate and some other fluids. They are available in four body materials: cast iron, SG iron, carbon steel or stainless steel. All valves can be supplied with the standard metal-to-metal seats, stellite facing for increased resistance to wear or soft seats for tight shut-off. The standard stem sealing is by spring adjusted PTFE chevrons but high temperature graphite seals or metal bellows with supplementary safety packing may also be specified.

The QLM and QLD three port control valves can be used with the following actuators:

<b>Pneumatic:</b>	PN9000E series	<b>Electric:</b>	AEL3
	PN9000R series		AEL5
			AEL6

### Technical data

<b>Plug design</b>		"V" Port
<b>Plug characteristic</b>		Linear
<b>Leakage class</b>	Metal- to-metal seal	EN 60534-4 Class IV
	Stellite faced	Maximum of 0.005% of Kv
	PTFE soft seal	EN 60534-4 Class VI
<b>Rangeability</b>		30:1
<b>Travel</b>	DN15 - DN50	20 mm
	DN65 - DN100	30 mm
	DN125 - DN200	50 mm

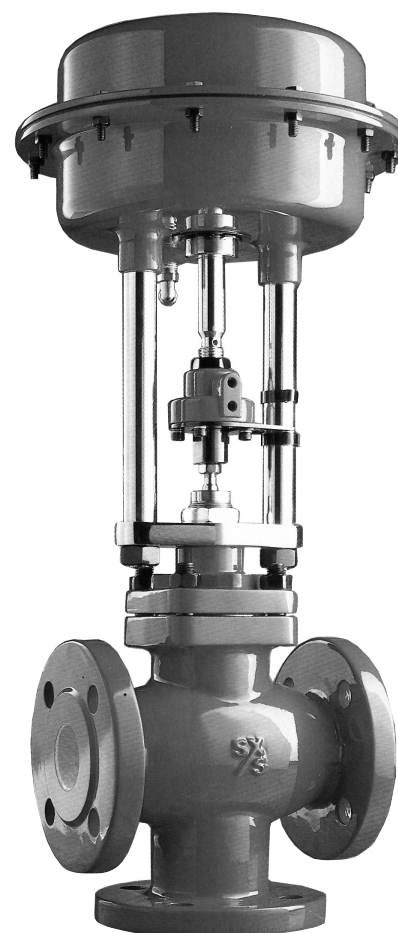

### Sizes and pipe connections

All valve flanges referred to in this document are in accordance with EN 1092.

**Note:** JIS and ASME flange options are also available on request.

	Type	Body material	Connection	Size range
<b>QLM:</b> Mixing service	QL33M	Cast iron	PN16	DN15, 20, 25, 32, 40, 50, 65, 80, 100, 125, 150 and 200
	QL43M*	Carbon steel	PN25/PN40	DN15, 20, 25, 32, 40, 50, 65, 80, 100, 125, 150 and 200
	QL63M*	Stainless steel	PN25/PN40	DN15, 20, 25, 32, 40, 50, 65, 80, 100, 125, 150 and 200
	QL73M	SG iron	PN16/PN25	DN15, 20, 25, 32, 40, 50, 65, 80, 100, 125, 150 and 200
<b>QLD:</b> Diverting service	QL33D	Cast iron	PN16	DN25, 32, 40, 50, 65, 80, 100, 125, 150 and 200
	QL43D*	Carbon steel	PN25/PN40	DN25, 32, 40, 50, 65, 80, 100, 125, 150 and 200
	QL63D*	Stainless steel	PN25/PN40	DN25, 32, 40, 50, 65, 80, 100, 125, 150 and 200
	QL73D	SG iron	PN16/PN25	DN25, 32, 40, 50, 65, 80, 100, 125, 150 and 200

\* **Note:** QL43M, QL43D, QL63M and QL63D three-port control valves are also available with PN16 flanges by special order.

## Operating limit conditions

QL33M and QL33D (cast iron)														
	Body		Standard				Bonnet Extended				Bellows			
			PTFE		Graphite		PTFE		Graphite		PN16		PN25	
Pressure (bar)	16	13	16	13	16	13	-	-	16	13	-			
Temperature (°C)	-5/+120	200	-5/+120	200	-5/+120	200	-	-	-5/+120	200	-			
QL73M and QL73D (SG iron)														
	Body		Standard				Bonnet Extended				Bellows			
			PTFE		Graphite		PTFE		Graphite		PN16		PN25	
Pressure (bar)	25	15	25	18.7	25	18	25	18	25	15	16	11	25	15
Temperature (°C)	-10/+120	300	-5/+120	232	-5/+120	250	-10/+120	250	-10/+120	300	-10/+120	300	-10/+120	300
QL43M and QL43D (carbon steel)														
	Body		Standard				Bonnet Extended				Bellows			
			PTFE		Graphite		PTFE		Graphite		PN16		PN25	
Pressure (bar)	40	21	40	33	40	32	40	32	40	21	16	10	25	16
Temperature (°C)	-29/+120	400	-5/+120	232	-5/+120	250	-29/+120	250	-29/+120	400	-10/+120	350	-10/+120	350
QL63M and QL63D (stainless steel)														
	Body		Standard				Bonnet Extended				Bellows			
			PTFE		Graphite		PTFE		Graphite		PN16		PN25	
Pressure (bar)	40	22.1	40	26.8	40	26.2	40	26.2	40	22	16	10	25	16
Temperature (°C)	-29/+120	400	-5/+120	232	-5/+120	250	-29/+120	250	-29/+129	400	-10/+120	350	-10/+120	350

## Differential pressure

For the maximum available differential pressures, see the relevant pneumatic or electrical actuator Technical Information sheets.

## Pressure/temperature limits

**QL33M and QL33D  
(cast iron)**

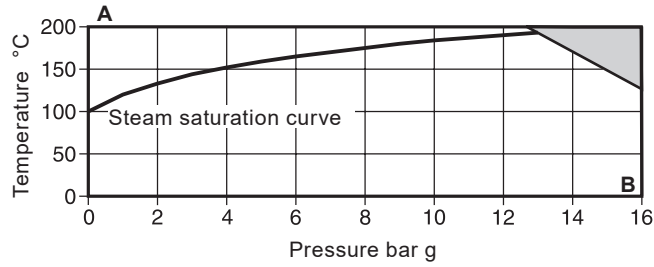

**A - B** Flanged PN16

**QL73M and QL73D  
(SG iron)**

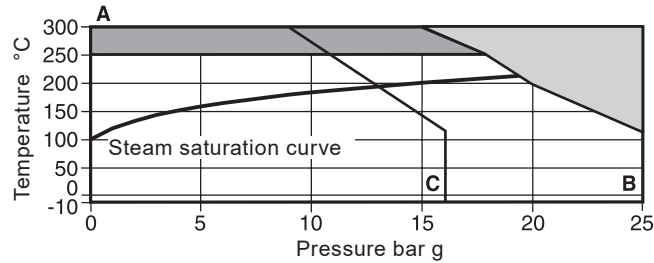

**A - B** Flanged PN25

**A - C** Flanged PN16

**QL43M and QL43D  
(carbon steel)**

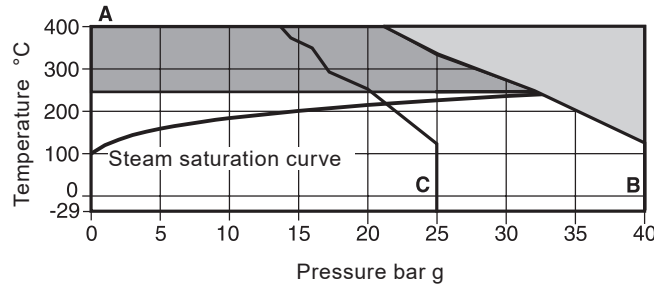

**A - B** Flanged PN40

**A - C** Flanged PN25

**QL63M and QL63D  
(stainless steel)**

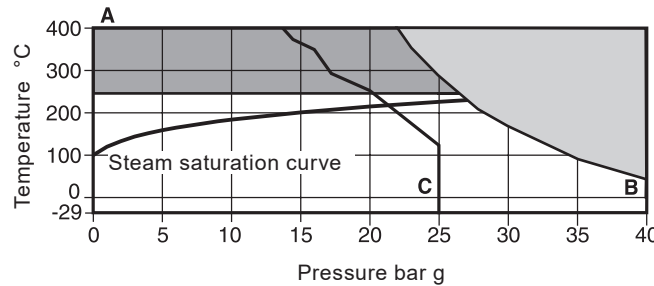

**A - B** Flanged PN40

**A - C** Flanged PN25

 The product **must not** be used in this region.

 High temperature packing is required.

<b>Body design conditions</b>	QL33M and QL33D	PN16	
	QL43M, QL43D, QL63M and QL63D	PN40	
	QL73M and QL73D	PN25	
<b>Maximum differential pressures</b>	See specific actuator Technical Information Sheet.		
<b>Stem seal:</b>	Standard bonnet	PTFE	Maximum 232 °C
		Graphite	Maximum 250 °C
	Extended bonnet	PTFE	Maximum 250 °C
		Graphite	Maximum 400 °C

## Materials - Cast iron, SG iron and carbon steel valves

Type	No.	Part	Material	Material designation ASTM/DIN STD
Cast iron	1	Body	Cast iron	EN-GJL-250
	2	Standard bonnet	SG iron	EN-GJS-400-18
		Extended bonnet	Carbon steel	1.0460
SG iron	1	Body	SG iron	EN-GJS-400-18
	2	Standard bonnet	SG iron	EN-GJS-400-18
		Extended bonnet	Carbon steel	1.0460
Carbon steel	1	Body	Carbon steel	1.0619
	2	Standard bonnet	Carbon steel	1.7131
		Extended bonnet	Carbon steel	1.0460
Cast iron SG iron Carbon steel	3	Plug(s)	Stainless steel	BS 970 431 S29
	4	Valve seats	Stainless steel	BS 970 431 S29
	5	Valve stem	Stainless steel	BS 970 431 S29
		Bellows	Stainless steel	AISI 316 L
	6	Spacer	Stainless steel	AISI 304
	7	Stuffing box gasket	Graphite	
	8	Lock-nut	Stainless steel	AISI 304
	9	Stuffing box	Stainless steel	BS 970 431 S29
	10	Mounting nut	Zinc plated steel	NFA 35553 XC 18S
	11	Packing	PTFE/graphite	PTFE/graphite
	12	Spring	Stainless steel	BS 2056 316 S42
	13	Bonnet gasket	Graphite	
	14	Stud	Carbon steel	A193 B7M
	15	Nut	Carbon steel	A194 Gr. 2H
	16	Lock-nut	Stainless steel	AISI 316
	17	Guide bush	PTFE	
	18	Stem guide bush	Stainless steel	Hardened AISI 440B
	19	Lock-nut	Stainless steel	AISI 316
	20	Pin	Stainless steel	AISI 316
	21	Gasket	Graphite	
	22	Anti-rotation screw	Stainless steel	AISI 304

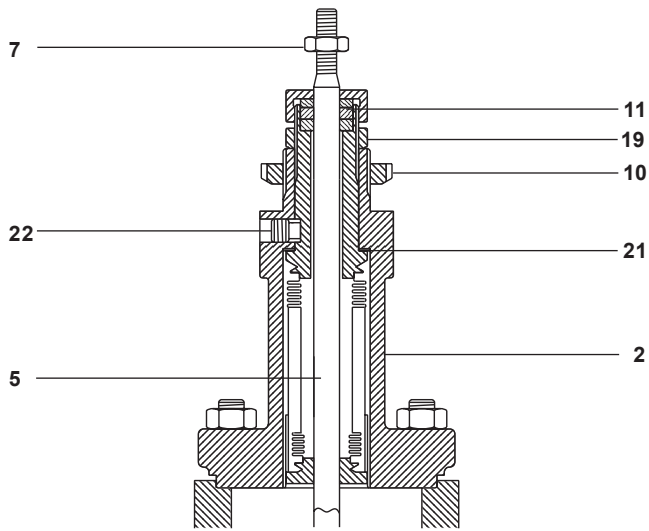

**Bellows gland seal**

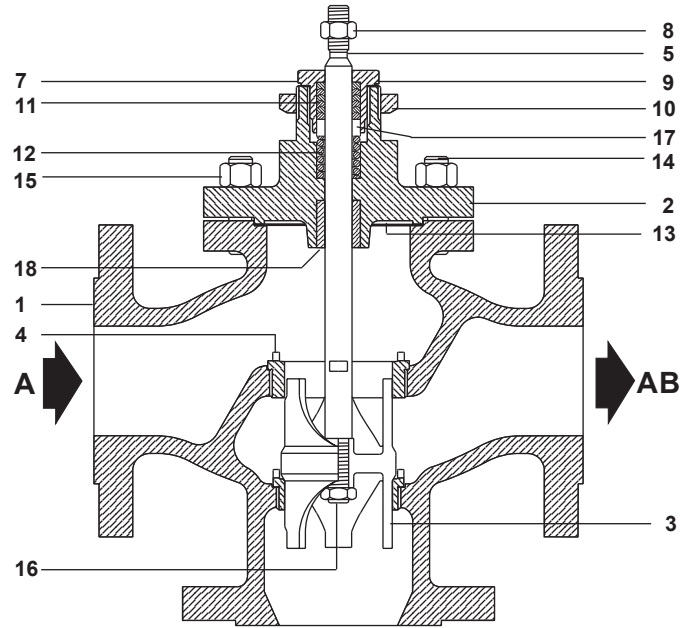

**QLM Mixing valve**

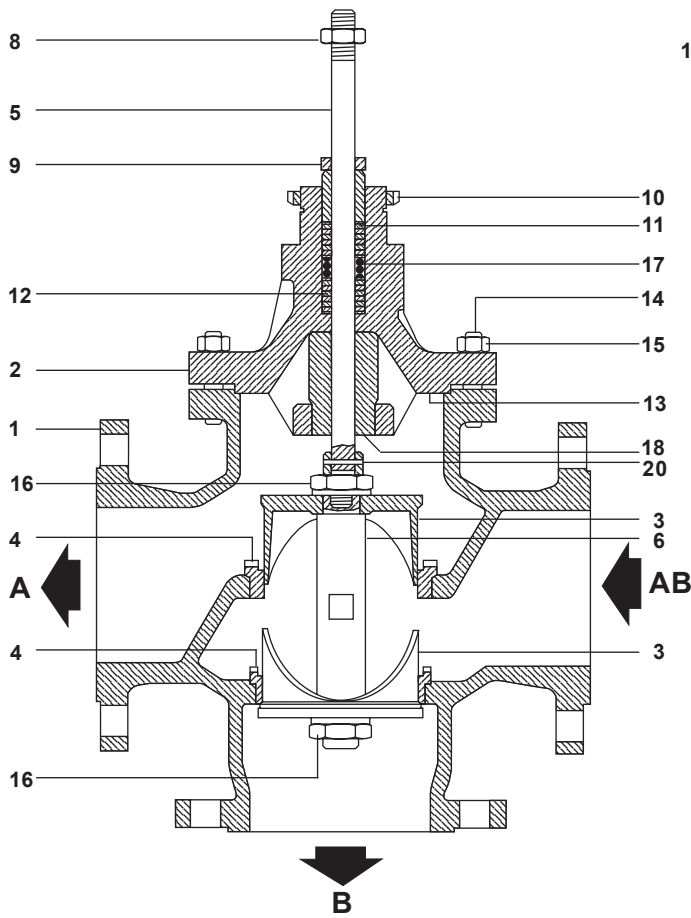

**QLD Diverting valve**

## Materials - Stainless steel valves

Type	No.	Part	Material	Material designation ASTM/DIN STD
Stainless steel	1	Body	Stainless steel	1.4552
	2	Standard bonnet	Stainless steel	1.4552
		Extended bonnet	Stainless steel	ASTM A182 F316
	3	Valve plug	Stainless steel	ASTM A351 CF8M
	4	Valve seat	Stainless steel	ASTM A276 316L
	5	Valve stem	Stainless steel	ASTM A276 316L
		Bellows	Stainless steel	AISI 316 L
	6	Spacer	Stainless steel	AISI 316
	7	Stuffing box gasket	Stainless steel	AISI 304
	8	Lock-nut	Stainless steel	AISI 316
	9	Stuffing box	Stainless steel	AISI 316
	10	Mounting nut	Zinc plated steel	NFA 35553 XC 18S
	11	Packing	PTFE/graphite	PTFE/graphite
	12	Spring	Stainless steel	BS 2056 316 S42
	13	Bonnet gasket	Graphite	
	14	Stud	Stainless steel	A193 B8
	15	Nut	Stainless steel	A194 Gr. 304
	16	Lock-nut	Stainless steel	AISI 316
	17	Guide bush	PTFE	
	18	Stem guide bush	Stainless steel	Hard faced AISI 316
	19	Lock-nut	Stainless steel	AISI 316
	20	Pin	Stainless steel	AISI 316
21	Gasket	Graphite		
22	Anti-rotation screw	Stainless steel	AISI 304	

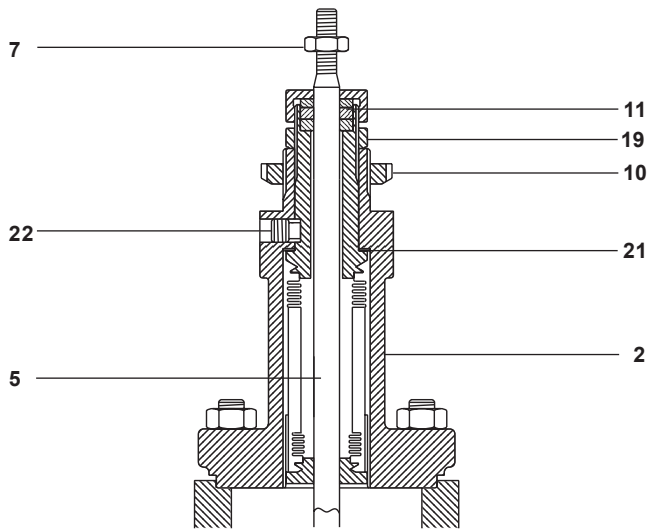

**Bellows gland seal**

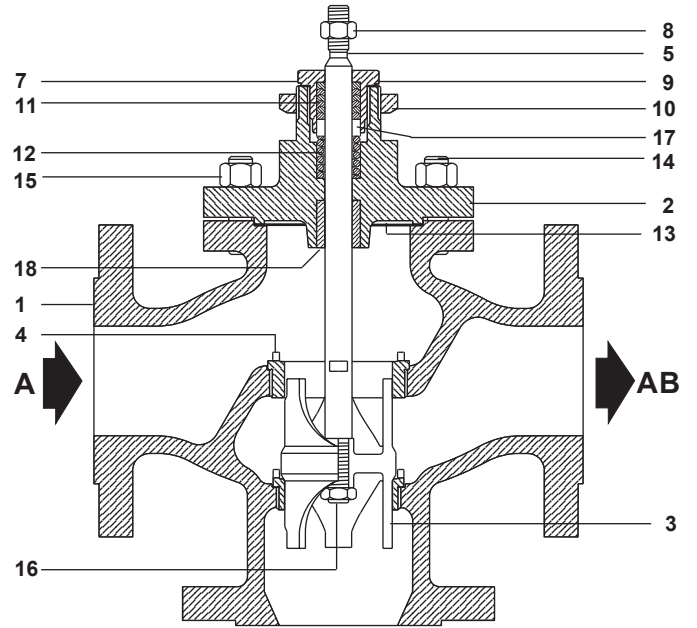

**QLM Mixing valve**

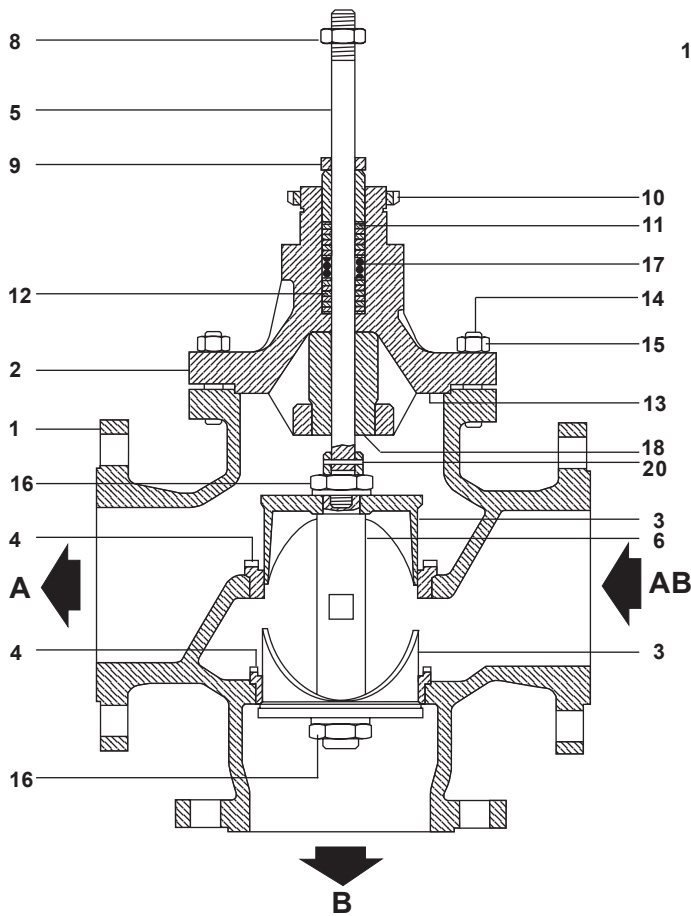

**QLD Diverting valve**

## Kv flowrate coefficients and travel

Nominal size		DN15	DN20	DN25	DN32	DN40	DN50	DN65	DN80	DN100	DN125	DN150	DN200
Travel	mm	20	20	20	20	20	20	30	30	30	50	50	50
Mixing service	$K_v$	4	6	10	17	25	35	62	100	130	195	310	450
Diverting service	$K_v$	-	-	10	17	25	35	62	100	130	195	310	450

$K_v$  flowrate coefficients are shown in metric units ( $K_v$  = water flowrate in m<sup>3</sup>/h with 1 bar differential pressure).

### For conversion:

$$C_v \text{ (UK)} = K_v \times 0.963$$

$$C_v \text{ (US)} = K_v \times 1.156$$

## Dimensions and weights (approximate) in mm and kg

Size	Dimensions (mm)				Weights (kg)	
					Bonnets	
	A	D	C	C1*	Standard	Extended/Bellows
DN15	130	90	105	166	6.5	7.9
DN20	150	95	105	166	6.9	8.3
DN25	160	100	109	170	8.8	10.2
DN32	180	105	124	185	11.0	12.4
DN40	200	115	137	190	14.5	15.9
DN50	230	125	143	196	18.5	20.0
DN65	290	145	160	357	31.0	33.0
DN80	310	155	165	361	40.8	42.8
DN100	350	175	180	373	48.5	50.5
DN125	400	200	280	445	78.0	81.0
DN150	480	225	300	463	115.0	118.0
DN200	600	275	370	554	143.0	147.0

**Note:** The C1 dimension shown refers to valves fitted with an extended bonnet, with or without PN16 and PN25 bellows.

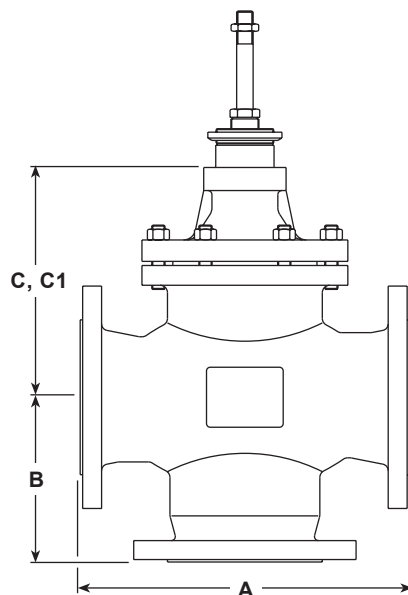



## Q series control valve selection guide:

	DN15 and DN20 (mixing service only)	
<b>Valve size</b>	DN25, DN32, DN40, DN50, DN65, DN80, DN100, DN120, DN150 and DN200 (mixing and diverting service)	<b>DN25</b>
<b>Valve series</b>	Q = Q series 3-port	<b>Q</b>
<b>Valve characteristic</b>	L = Linear 3 = Cast iron	<b>L</b>
<b>Body material</b>	4 = Carbon steel 6 = Stainless steel 7 = SG iron	<b>4</b>
<b>Connections</b>	3 = Flanged	<b>3</b>
<b>3-port design</b>	D = Diverting M = Mixing Blank = Standard PTFE chevron	<b>M</b>
<b>Stem sealing</b>	H = Graphite packing B1 = PN16 bellows seal B2 = PN25 bellows seal Blank = Standard metal-to-metal	
<b>Seating option</b>	W = Hard facing (stellite) G = Soft seal (PTFE)	
<b>Other options</b>	Blank = Standard X = Extended bonnet	
<b>Flow coefficient</b>	To be specified	<b>K<sub>v</sub>10</b>
<b>Connection type</b>	To be specified	<b>PN40</b>

### Selection example:

DN25	Q	L	4	3	M				K <sub>v</sub> 10	PN40
------	---	---	---	---	---	--	--	--	-------------------	------

### How to order

**Example:** 1 off Spirax Sarco DN25 QL43M Kv10 flanged to PN40.

## Spare parts

The spare parts available are in heavy outline. Parts drawn in broken line are not supplied as spares. These spares are for the following valves:-

QL33D, QL43D, QL63D, QL73D	Diverting	DN25 to DN200
QL33M, QL43M, QL63M, QL73M	Mixing	DN15 to DN200

### Available spares

Actuator clamping nut	<b>A</b>
PTFE gland seal kit for DN15 to DN50 only (gasket, chevrons, spring, upper and lower bearings and 'O' ring)	<b>B</b>
PTFE gland seal kit for DN65 to DN100 only (gasket, chevrons, guide bush, spring)	<b>B1</b>
PTFE gland seal kit for DN125 to DN200 only (gasket, chevrons, guide bush, spring)	<b>B2</b>
Graphite gland seal kit for DN15 to DN200 (graphite stem seals and stuffing box gasket)	<b>C</b>
Stem, plug and bonnet gasket	<b>D, E</b>
Bonnet gasket (packet of 3)	<b>E</b>
Seats (1 off top and bottom)	<b>F</b>

**Note:** PTFE and graphite seal kits are suitable for stuffing box and extended bonnet versions.

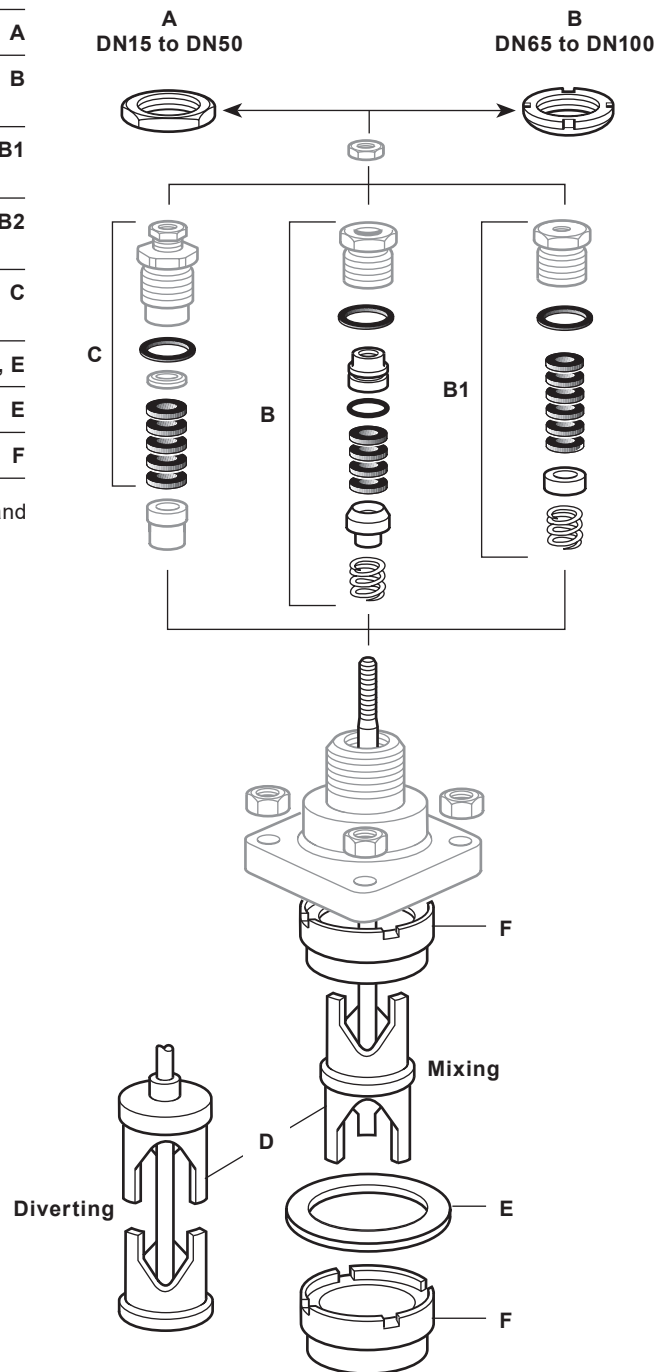

## Available spares for valves with bellows seal

Graphite gland seal kit	(packing set)	<b>AS</b>
Seats	(2 items)	<b>BS</b>
Bonnet gasket	(packet of 3)	<b>CS</b>
Bellows gasket	(packet of 3)	<b>DS</b>
Bellows, stem, plug and bellows gasket	Mixing valves Diverting valves	<b>FS, CS, DS</b> <b>FS, CS, DS</b>

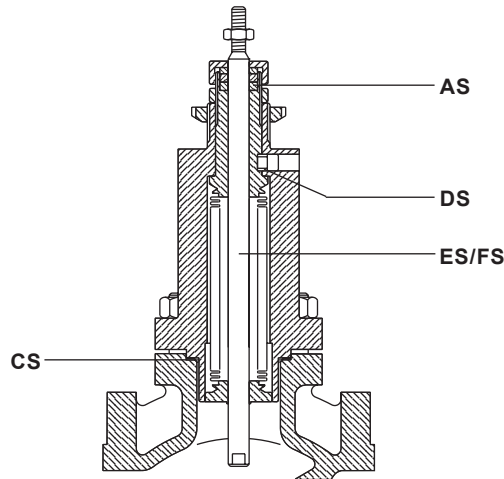

### How to order spares

Always order spares by using the description given in the column headed 'Available spares', and state the size and type of valve including the date code of the product.

**Example:** 1 - PTFE gland seal kit for a Spirax Sarco DN65 QL43M three port control valve. Date coded C03.

### How to fit spares

Full fitting instructions are given in the Installation and Maintenance Instructions supplied with the spare.