



## USTS II Universal Steam Trap Station (Requires Universal Trap of Choice)

### Description

The USTS-II Universal steam trap station is designed to have inlet and outlet isolation valves, an integral strainer with blowdown and a test valve. Designed as a complete steam main drip or tracer steam trap station. The station will support all of the Spirax Sarco universal connection steam traps.

Model	USTS II
PMO	650 psi g (45 bar g)
Sizes	½", ¾" (DN15, DN20)
Standard Flow Direction	Left to Right (Right Hand)
Connections	NPT, SW
Construction	Stainless Steel
Optional Flow Direction	Right to Left (Left hand), handle option

### Limiting operating conditions

PMO Maximum operating pressure	650 psi g (45 bar g)
TMO Maximum operating temperature	750 °F (399 °C)
PMA Pressure shell design conditions	650 psi g (45 bar g)

Right hand version

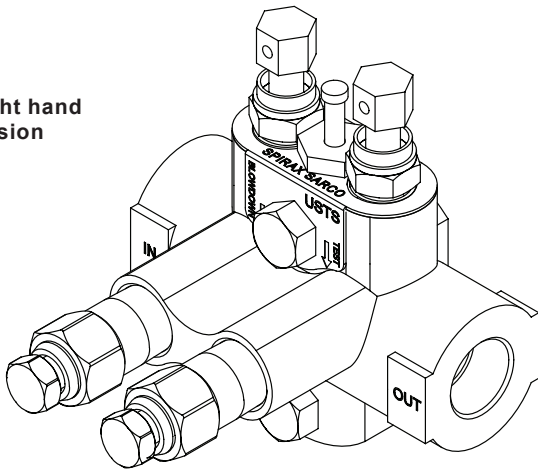

Optional handle version

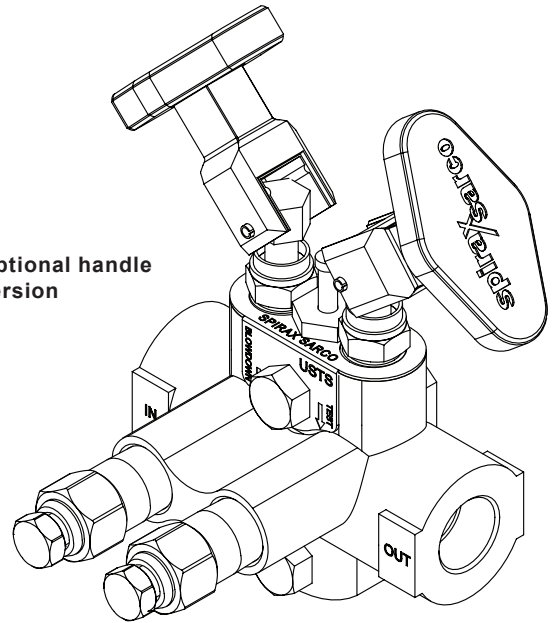

### Compatible Spirax Sarco Universal Steam Traps

Trap type	Model	Model	Model	Model
Thermodynamic	UTD52L	UTD52H	UTD52-HP	UTDS52L
Balanced pressure	UBP32			
Inverted Bucket	UIB30/4	UIB30/5	UIB30/6	UIB30H/8
Inverted Bucket	UIB30H/10			
Float and thermostatic	UFT32-4.5	UFT32-10	UFT32-14	UFT32-21
Float and thermostatic	UFT32-32			
Bimetallic	USM21			

## Materials

### Right hand version

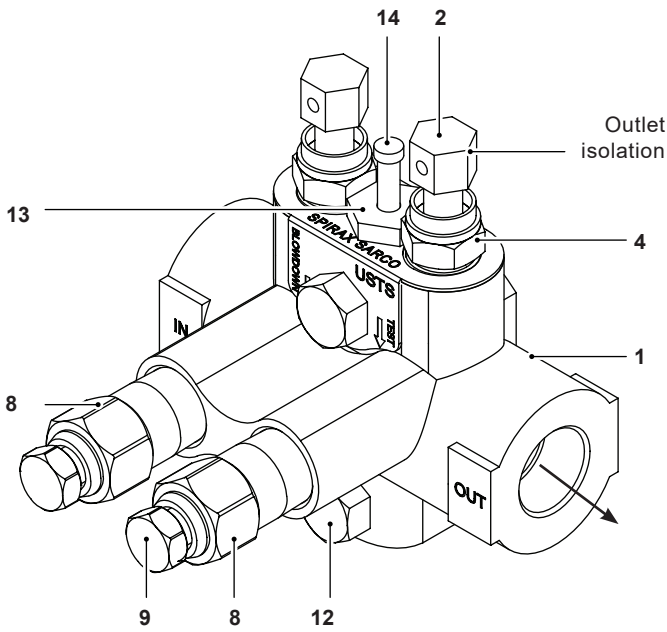

### Optional handle version

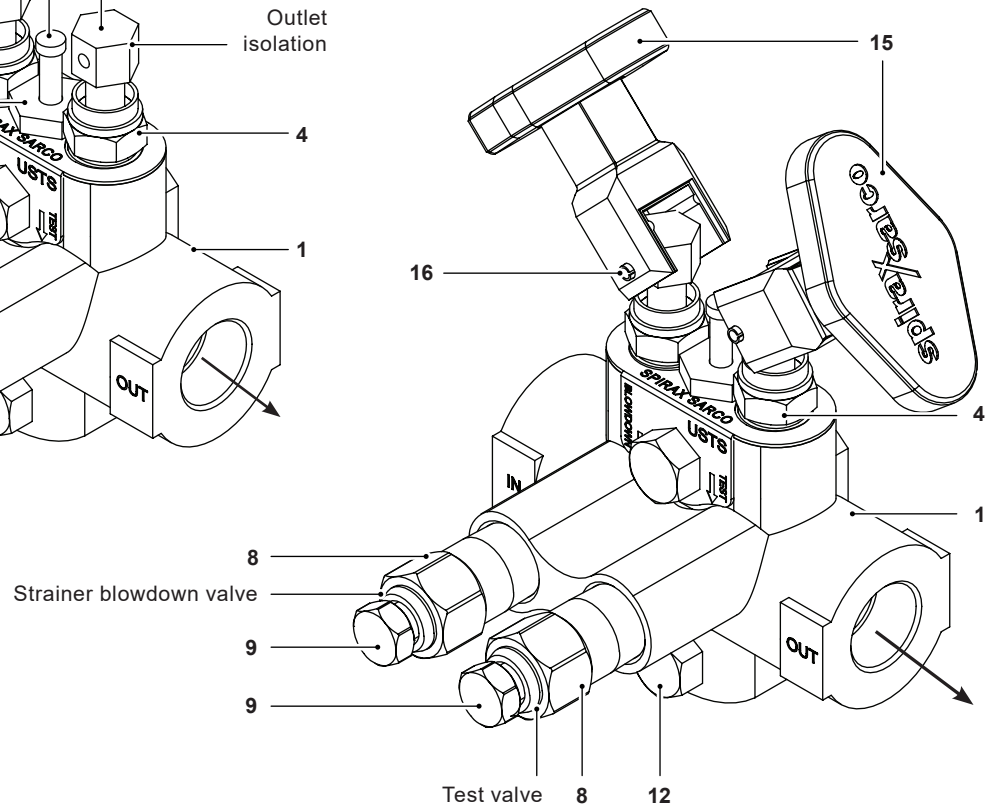

No.	Part	Material	
1	Body casting	Stainless steel	ASTM A351 CF8
2	Valve spindle	Stainless steel	
3	Valve head (internal)	Stainless steel	
4	Valve packing unit	Stainless steel	
5	Valve packing (internal)	Graphite	
6	Washers (internal)	Stainless steel	
7	Strainer screen (internal)	Stainless steel	
8	Blowdown valve body	Stainless steel	
9	Blowdown valve stem	Stainless steel	
10	Blowdown ball head (Internal)	Stainless steel	
11	Blowdown retaining clip (internal)	Stainless steel	
12	Connector screws	Alloy steel (Plated)	ASTM A193 Gr.B7
13	Locking Nut	Stainless steel	
14	Locking Nut Pin	Stainless steel	
15	Handle	Stainless steel	
16	Handle Pin	Stainless steel	

**Dimensions/weights** (approximate in inches (mm) and lbs (kgs))

Right hand version shown

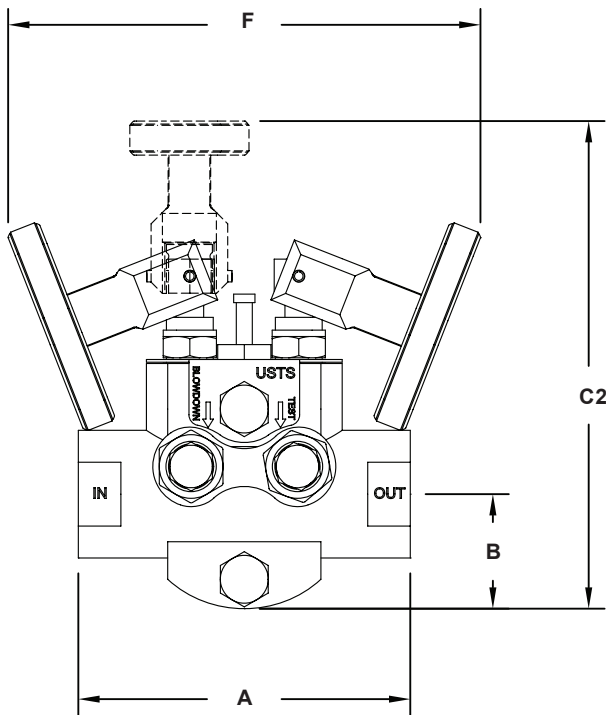
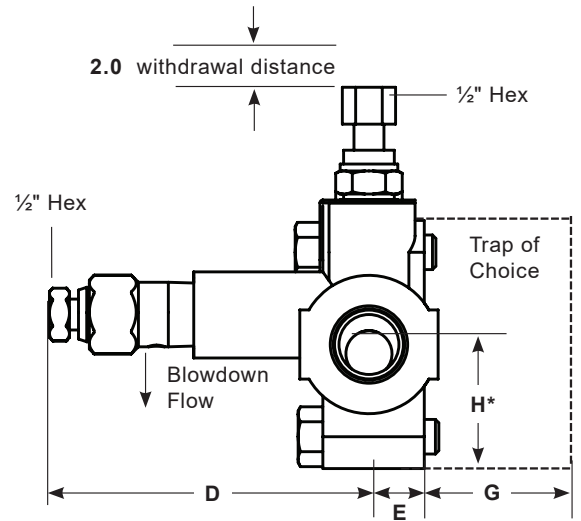
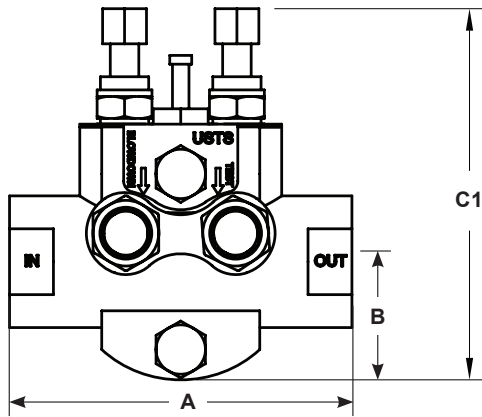

**Dimensions**

A	B	C1	C2	D	E	F
3.9" (99)	1.4" (36)	3.7" (94)	5.7" (145)	3.5" (89)	.6" (15)	5.5" (140)

G	G	G	G	G	G
UTD52L	UTD52H	UFT32	UIB30	UIB30H	UBP32
4.3" (109)	4.8" (122)	9.0" (229)	6.2" (157)	9.6" (244)	3.2" (81)

H*	H*	H*	H*	H*	H*
UTD52L	UTD52H	UFT32	UIB30	UIB30H	UBP32
1.3" (33)	1.3" (33)	2.2" (56)	4.9" (124)	6.3" (160)	1.3" (33)

**Weights**

<b>Station weight (no trap)</b>	3.0 lbs (1.4 kg)	No handles
	3.7 lbs (1.7 kg)	With handles

\*H = Centerline of trap station connector to bottom of trap

## USTS II sample specification

The USTS steam trap station to be manufactured of all stainless steel construction. The station will have two isolation valves, one trap test valve and one strainer blowdown valve. The test valve is on the discharge side of the trap to test trap function: to depressurize that area, or to check the condensate return lines for plugging. The inlet isolation valve blocks the trap inlet while the outlet valves block the outlet to the condensate return line downstream of the test valve. The station is supplied with an integral inlet strainer with a blowdown valve for clean out and depressurized mode so the trap or strainer can be repaired or replaced. The station will accept all Spirax Sarco universal traps or any competitors traps who use the standard universal connector design. To be supplied with either left to right flow or right to left flow. Handle option available on all models.

## Installation

Valve handles to be in upward position, with the strainer pointing straight down and trap connection on the side. Mount selected trap to the connector and torque to proper torque level. On initial start-up turn inlet and outlet valves to test to blow any installation dirt and debris from the system, (be careful to stay away from flow). Turn both valves to the on position.

## How to order

Model number/pipe size/connection type

Example: USTS II ¼" NPT (L/R right hand)

## Optional

Lock-out/Tag-out Box for Isolation Valves or Blowdown Valves On Stations Without Handles

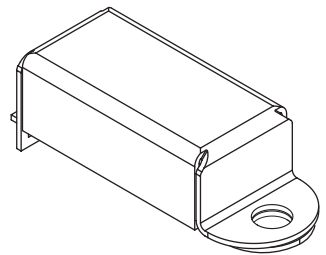

## Spares parts

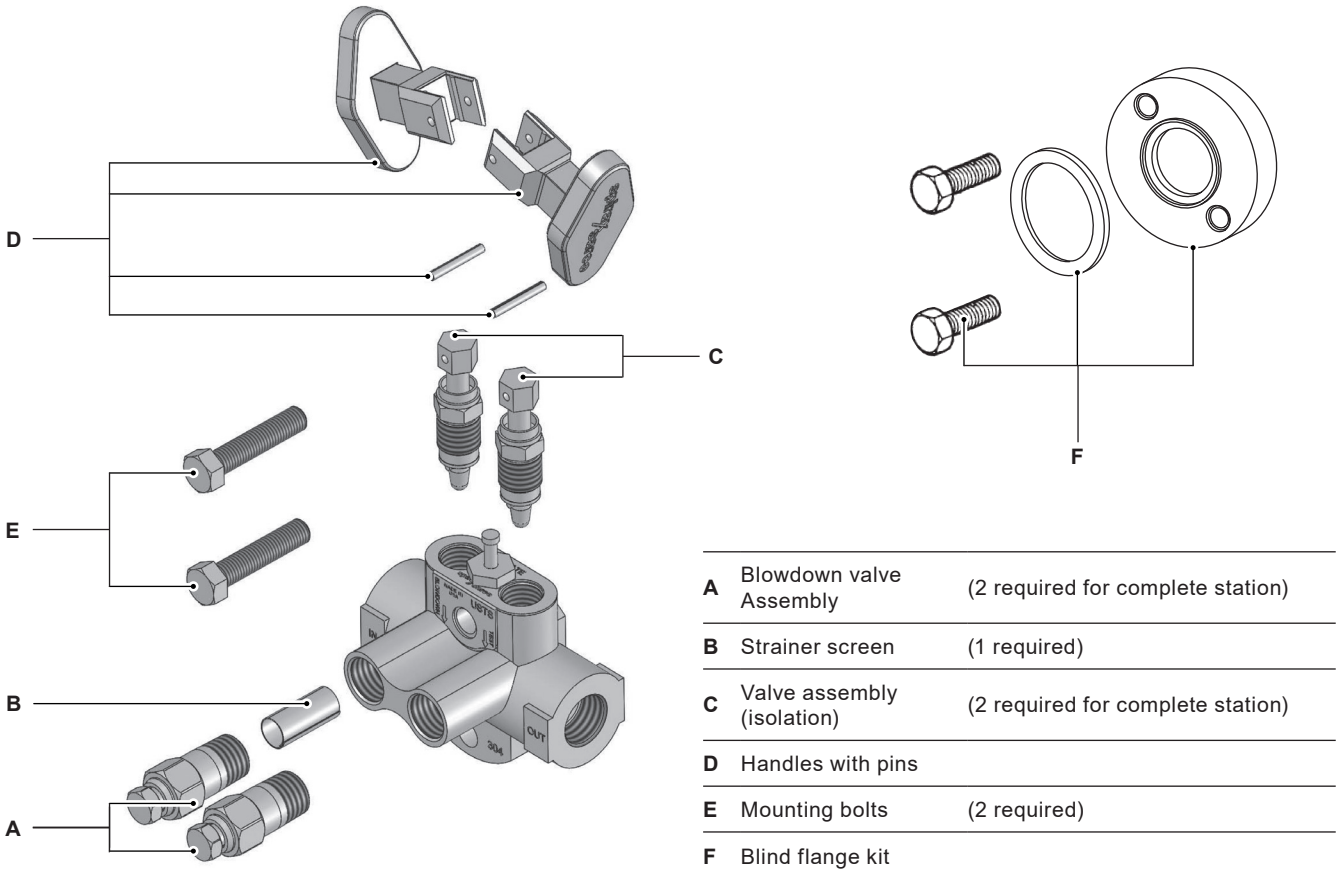

<b>A</b>	Blowdown valve Assembly	(2 required for complete station)
<b>B</b>	Strainer screen	(1 required)
<b>C</b>	Valve assembly (isolation)	(2 required for complete station)
<b>D</b>	Handles with pins	
<b>E</b>	Mounting bolts	(2 required)
<b>F</b>	Blind flange kit	