



## UFT32 Series

# Sealed Stainless Steel Float & Thermostatic Steam Trap (for use with Universal Connectors)

<b>Model</b>	UFT32-4.5, UFT32-10, UFT32-14, UFT32-21, UFT32-32
<b>Trap Construction</b>	Stainless Steel
<b>Connector Sizes</b>	½", ¾", 1"
<b>Connector Connections</b>	NPT, SW
<b>Connector Construction</b>	Straight or strainer type (left or right hand) Stainless steel or cast steel
<b>Connector Options</b>	SW connections to ANSI B16.11 Carbon steel USTSII trap station

### Description

The UFT Series of Traps is an austenitic stainless steel maintenance free sealed ball float steam trap with an integral automatic air venting capability. The UFT is designed for differential steam pressures up to 465 psi g. When installed with a suitable pipeline connector the UFT can easily and simply be removed without breaking into the pipeline, thus speeding up trap replacement with minimal system downtime. Pipeline connectors are available with screwed, socket weld and flanged end connections.

### Standards

The body to cover welded joint complies with ASME Section IX and BS/EN 288

This product fully complies with the requirements of the European Pressure Equipment Directive (PED).

### Certification

The product is available with material certification to EN 10204 3.1.B as standard and must be specified at the time of order placement.

### Sizes and pipe connections

The UFT can be fitted to a variety of different pipeline connectors including:

- Universal straight connector ½", ¾", 1"
- Strainer connector ½", ¾", 1"
- Standard or Left Hand with Blowdown Valve

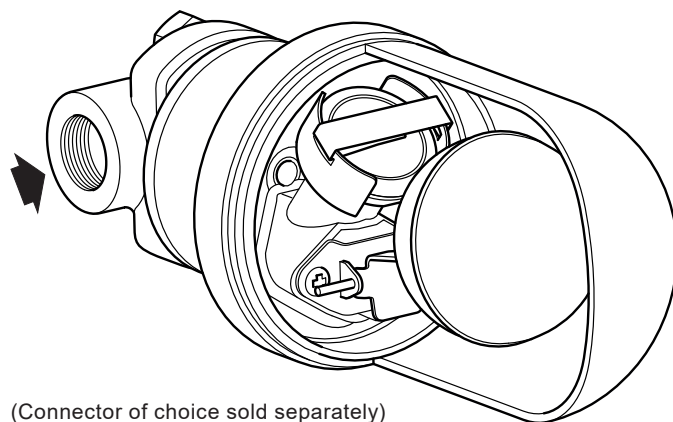

(Connector of choice sold separately)

### Options: Consult factory

Bimetal Air Vent (for temperature outside operation range)  
 Fixed Bleed Option (notched seated) for Sulphur recovery pits for continuous bleed where steam locking can occur. Noted by "FB" after pressure notation, i.e. UFT 32-4.5 FB.

UFT32P with PEEK seat for use on copper tracing applications  
 (Only available in 4.5, 10, and 14 bar options).

### ΔPMX - Maximum differential pressure

UFT32-4.5	UFT32-10	UFT32-14	UFT32-21	UFT32-32
65 psi g	150 psi g	203 psi g	300 psi g	465 psi g
4.5 bar g	10 bar g	14 bar g	21 bar g	32 bar g

## Pressure/temperature limits (ISO6552)

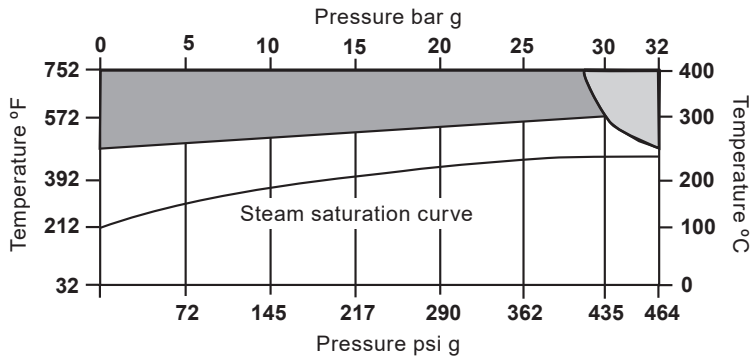

Maximum body design conditions		ANSI/ASME 300	
PMA - Maximum allowable pressure	725 psi g	50 bar g	
TMA - Maximum allowable temperature	752 °F	400 °C	
Designed for a maximum cold hydraulic test pressure of		948 psi g	64.5 bar g

- The product **must not** be used in this region.
- The product should not be used in this region or beyond its operating range as damage to the internals may occur.

## Materials

UFT32 fitted to a PC10HP connector

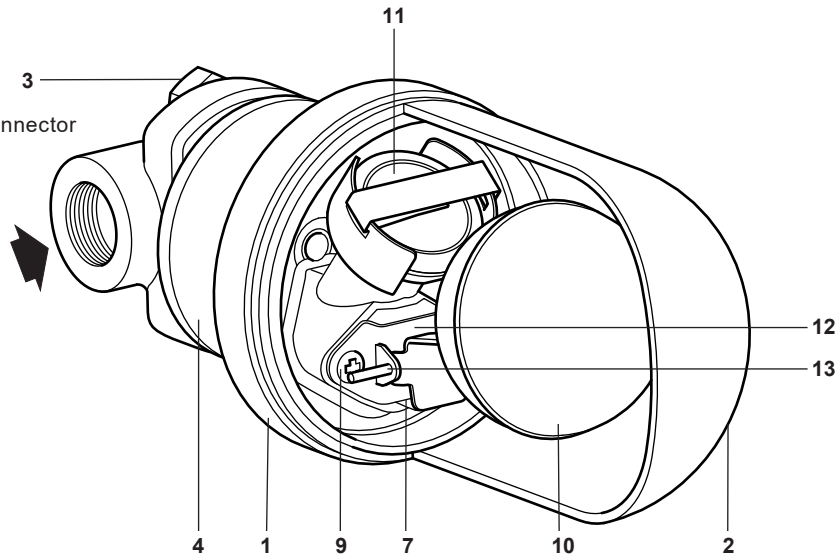

No.	Part	Material	
1	Body	Austenitic stainless steel 304	EN 10213-4 1.4308; ASTM A351 CF8
2	Cover	Austenitic stainless steel 304	EN 10213-4 1.4308; ASTM A351 CF8
3	Connector screws	Steel	ASTM A193 B7
4	Flange	Alloy steel	A322 Gr.4130
5	Inner gasket	Stainless steel/graphite filler	Spirally wound AISI 304 strip
6	Outer gasket	Stainless steel/graphite filler	Spirally wound AISI 304 strip
7	Main valve seat	Stainless steel	BS 970 431 S29
8	Main valve/air vent seat gasket	Stainless steel	BS 1449 304 S11
9	Main valve assembly screws	Stainless steel	BS 6105 CI A2-70
10	Ball float and lever	Stainless steel	BS 1449 304 S16
11	Air vent assembly	Stainless steel	
12	Pivot frame	Stainless steel	BS 1449 304 S16
13	Pivot pin	Stainless steel	

## Dimensions/weight

(approximate) in inches and lbs (mm and kg)

A	B	C	Weight
6.63"	3.7"	1.85"	4.5 lbs
168.5 mm	94 mm	47 mm	2.02 kg

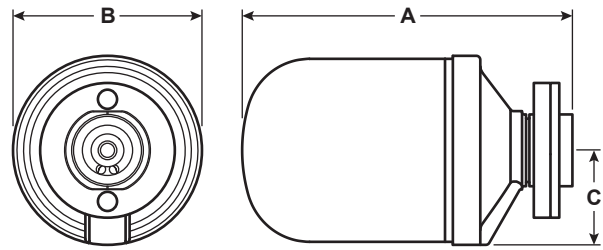

## Safety information, installation and maintenance

For full details see the Installation and Maintenance Instructions (IM-P146-01) supplied with the product.

## How to specify

Steam traps shall be sealed ball float traps UFT type suitable for a differential operating pressure of either 65, 150, 203,300 or 465 psi g. Traps to be zero maintenance and be connected to a separate pipeline connector by two screws to allow for quick and simple installation/replacement. For example Spirax Sarco UFT32-10 ball float steam trap.

## How to order

When ordering a UFT and connector they must be ordered individually as they are supplied as separate components to ease installation. Each UFT is supplied in a protective box complete with inner and outer gasket (securely crimped in place) and two connector screws.

**Example:** 1 of Spirax Sarco UFT sealed stainless steel ball float steam trap (for use with pipeline connectors).

## Capacities (in accordance with ISO 7842)

**Note:** Capacities shown are based on discharge at saturation temperature. When discharging sub-cooled condensate the air vent provides extra capacity. Under start-up conditions the thermostatic air vent will be open, and will provide additional condensate capacity to the main valve assembly. This will provide a minimum of 100% increased capacity above the hot condensate figures shown.

### UFT32 Series Hot Condensate Capacity #/hr.

Pressure (psi g)	UFT 32-4.5	UFT 32-10	UFT 32-14	UFT 32-21	UFT 32-32
10	380	263	183	160	98
25	562	383	275	241	153
50	753	508	374	330	213
65	842	566	420	371	242
100		674	509	451	298
150		796	609	542	362
200			692	617	416
300				741	505
400					624
464					704

## Spare parts

The UFT32 is a sealed non-maintainable trap unit. No internal spares are available.

The spares that are available are shown in solid outline. Parts shown in a grey line are not available as spares.

## Available spares

Connector screws (x 2)

3

Complete UFT32 trap unit inclusive of gaskets and connector screws (3)



## How to order spares

Always order spare parts by using the description given in the column headed 'Available spares' and state the size, model no. and pressure rating of the trap.

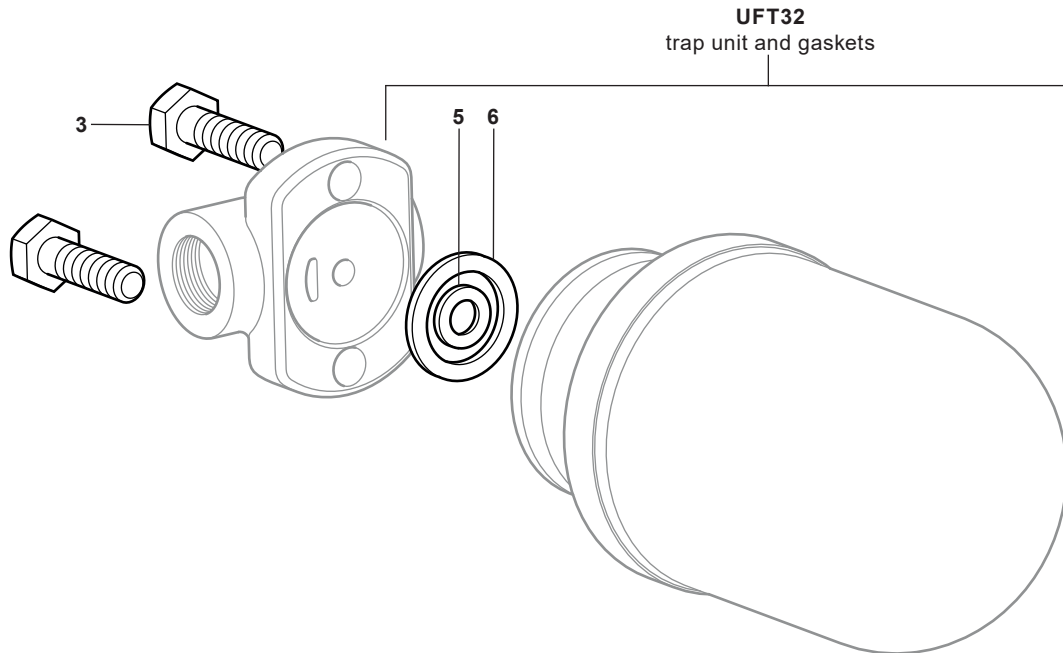
**Example:** 2 x Connector screws for a Spirax Sarco UFT32 sealed stainless steel ball float steam trap (for use with pipeline connectors).



## Recommended tightening torques

Item	Part	 or 	Ft/Lbs
3	Connector screws	$\frac{9}{16}$ " A/F	22-26