

SX80 Process Controller

Description

The SX80 controller is a 1/16 DIN panel mounted unit, suitable for single and multiple set point applications utilising the Spirax Sarco range of pneumatic or electric control valves and electrical and electropneumatic instruments. The SX80 has both VMD (3 point) and analogue (4-20 mA) outputs in the same unit and features quick start codes for ease of commissioning.



SX80 features:

- **Universal input** - Resistance thermometers, thermocouples, mA and mV.
- **Universal output** - VMD (valve motor drive), mA and voltage for continuous, relay and logic for switching control.
- **Auxiliary power supply** - For external transmitter requiring 18 Vdc.
- **Text messages** - Scrolling text messages can be configured to alert the user to process conditions.
- **Quick codes** - 5-digit quick codes enable easy set-up and commissioning of the controllers.

Approvals

These controllers conform to the Council Directive 93/68/EEC and the regulations on the essential protection requirements in Electrical Apparatus EN 61010-1: 90

- **EMC emissions specification:** EN 61326-1: 1997 Class B (including amendments A1, A2 and A3).
- **EMC immunity specification:** EN 61326-1: 1997 Industrial locations (including amendments A1, A2 and A3).

See overleaf for SX80 Process Controller technical data

Dimensions (approximate) in inches (mm)

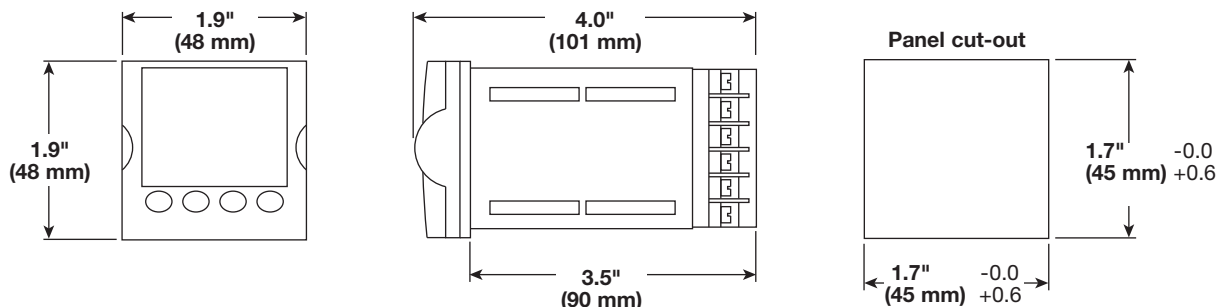

How to order example: 1 off Spirax Sarco SX80 process controller.

Local regulation may restrict the use of this product below the conditions quoted. Limiting conditions refer to standard connections only. In the interests of development and improvement of the product, we reserve the right to change the specification.

SX80 Process Controller

Technical data

General details

Mounting arrangement	Panel mounted 1/16 DIN
Power supply	85 to 265 Vac, 6 W maximum
Electrical connections	Screw connection terminal block
Panel sealing	IP65 – plug in from front panel, NEMA 4X
Operating temperature/humidity	0 to 55°C, 5 to 85% RH
Atmospheres	Not suitable for use in explosive or corrosive atmospheres
Electromagnetic compatibility (EMC)	EN 61326
Electrical safety BS EN 61010	Installation Category II
Weight	0.6 lb (250 g)
Approvals	CE

Process variable inputs

Calibration accuracy	< ±0.25% reading ±1 LSD
Resolution	< 0.5 µV with 1.6 second filter
Input filter	Off to 59.9 seconds
RTD	3 wire Pt100 DIN 43760
Bulb current	0.2 mA
Universal linear mA	4 - 20 mA, 0 - 20 mA, using external shunt resistor 2.49 Ω
Linear input range	-10 to 80 mV
Thermocouples	K, J, N, R, S, B, L, T, C, custom
Sampling rate	4 Hz (250 ms)
Cold junction accuracy	< ±1°C at 25°C ambient
Accuracy linear mA	< 0.1% reading
Input impedance	100 MΩ
Number of set points	3
User calibration	2 point gain and offset

Transmitter power supply

Isolation	300 Vac double isolated
Output voltage	18 V ±15%
Current	30 mA maximum
Load regulation	< 1 V over 25 mA

Control action

Proportional band	1 - 9999 Engineering units or 0.01 to 300 %age or 0.1 - 3000
Integral time	Off - 9999
Derivative time	Off - 9999
Error band	One shot tune, or natural frequency tune. The controller will automatically select the best method according to the process conditions.
Auto tuning	Hysteresis from 0.01 to 300.0 or 0.1 to 3000 Engineering units
On-off control	1 - 9999 Engineering units or 0.01 to 300 %age or 0.1 - 3000
Cut back	To minimise overshoot on critical processes.
Auto / manual modes	Selectable from keyboard.

Relays

Isolation	300 Vac double insulated
Output range	0 - 20 mA, 4 - 20 mA
Resolution	13.5 bits
Contact rating	Maximum 2 A @ 264 Vac resistive
Note:	Maximum 2 A per terminal limit applies where relays have common terminals (2 amps maximum for terminal AB).

Logic inputs (x2)

Contact closure	Open >1200R Closed <300R
-----------------	-----------------------------

Isolated dc output

Isolation	300 Vac double insulated
Output range	0 - 20 mA, 4 - 20 mA
Resolution	13.5 bits

SX80 Process Controller

Wiring diagrams

Warning: Safe operation of this product can only be guaranteed if it is properly installed, commissioned, used and maintained by qualified personnel as stated in the IMI supplied with the unit. It is the duty of the Company Safety Officer to ensure that the product specific data and Safety information within the supplied IMI has been fully understood and complied with.

Terminal diagram

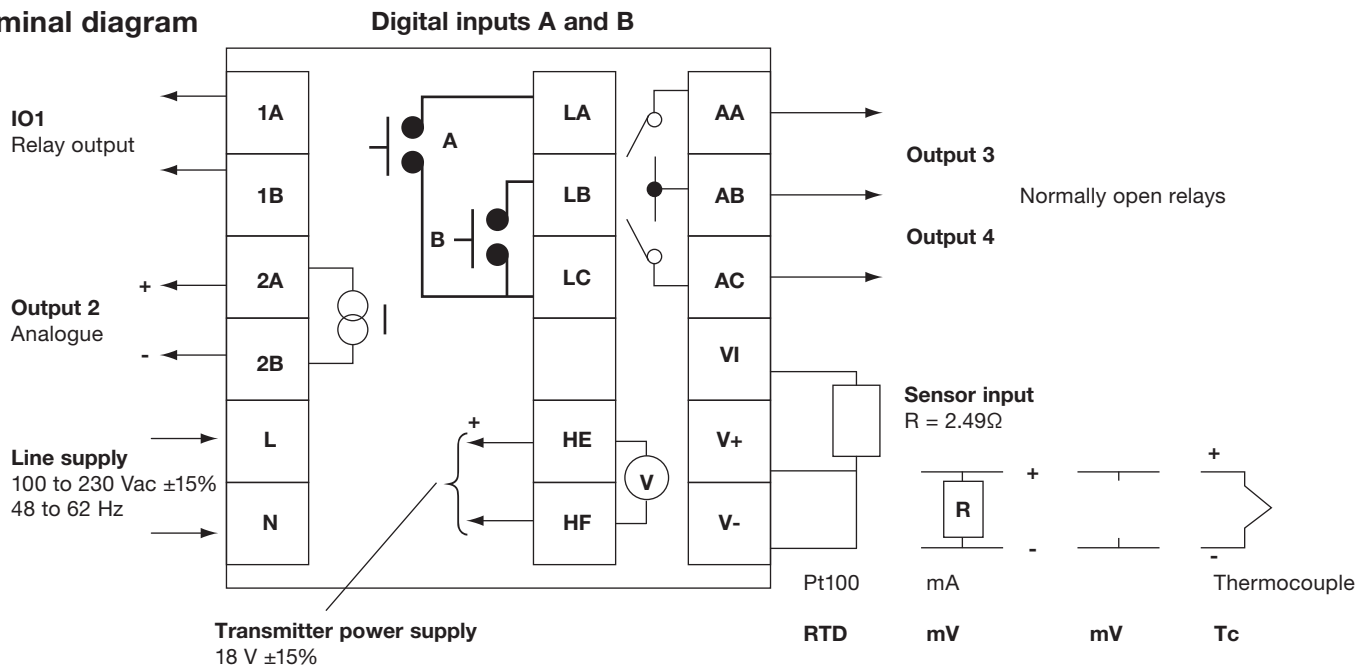

Wiring diagram for connecting a 4-20 mA transmitter

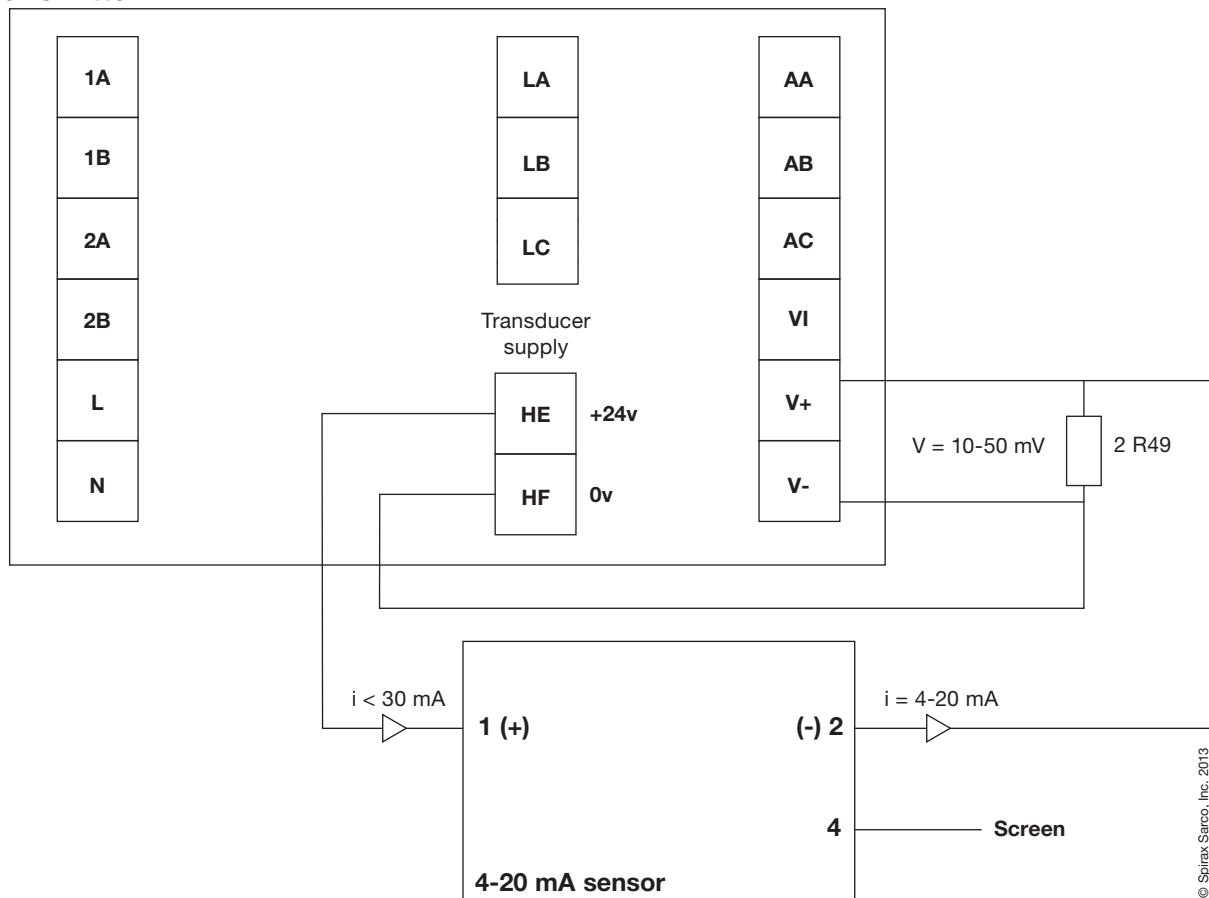

© Spirax Sarco, Inc. 2013