



Safety Valves SV74 Series

Description

The SV74 Series valves are built in conformance to Section I and VIII of the ASME boiler and pressure vessel code. They are primarily intended for use on power boilers and unfired pressure vessels where ASME Section I or VIII stamped valves are required. The orifice areas listed are actual orifice areas and should not be confused with the API effective orifice areas shown in most safety valve catalogs.

Model	SV74	
Sizes	1½" x 2" to 6" x 8"	
Connections	Inlet: ANSI 300 RF	Outlet: ANSI 150 RF
Construction	Cast Steel body with Stainless Steel Trim	
Options	Drip pan elbow-See TI-3-2141-US	

Typical applications

Protection of steam system downstream of pressure regulating stations, on inlet to such equipment as air coils, heat exchangers and process vessels. Also for use on flash recovery vessels on condensate return systems to protect vessels. Air systems to protect accumulation vessels and air equipment from over-pressurization. Steam boilers and generators.

Sizing data

See TI-3-2121-US.

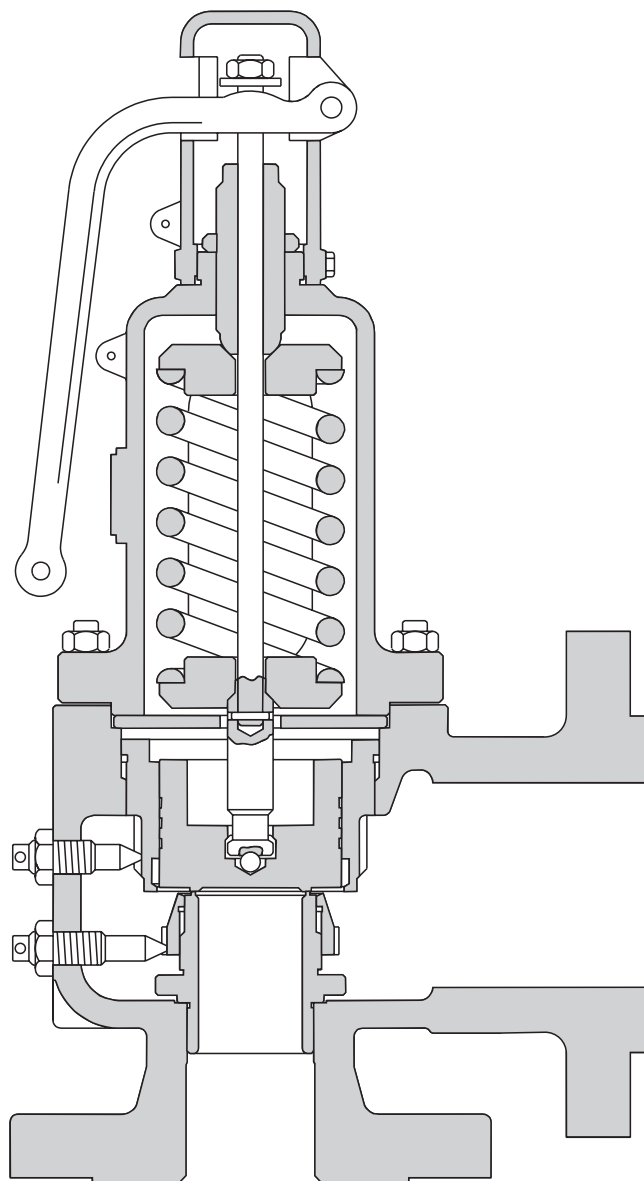

Pressure/Temperature limits

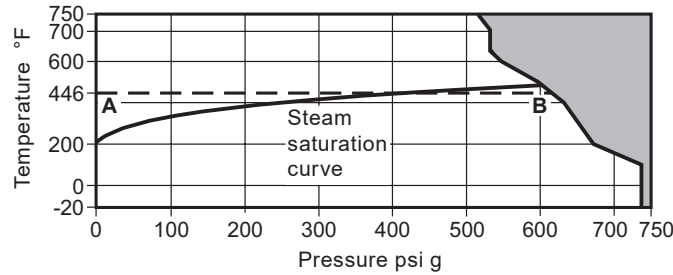

The product **must not** be used in this region.

A - B To avoid spring damage, **do not exceed** an operating temperature of 446 °F.

Body design conditions			ANSI 300
	Maximum		300 psi g
Set pressure range	Minimum		5 psi g
		Minimum 15 psi g ASME code stamped	
Design temperature	Maximum		750 °F
	Minimum		-20 °F
Operating temperature	Maximum		446 °F
	ASME I	Steam	3%
Overpressure	ASME VIII	Steam	10%
		Air/gas	10%
Performance data	ASME I	Steam	2 - 6%
Blowdown limits	ASME VIII	Steam	7%
		Air/gas	7%
Derated coefficient of discharge values		Steam	0.955
		Air/gas	0.955
Maximum permitted backpressure up to:			10% of set pressure
Tested at a maximum inlet cold hydraulic test pressure of:			1015 psi g

Materials

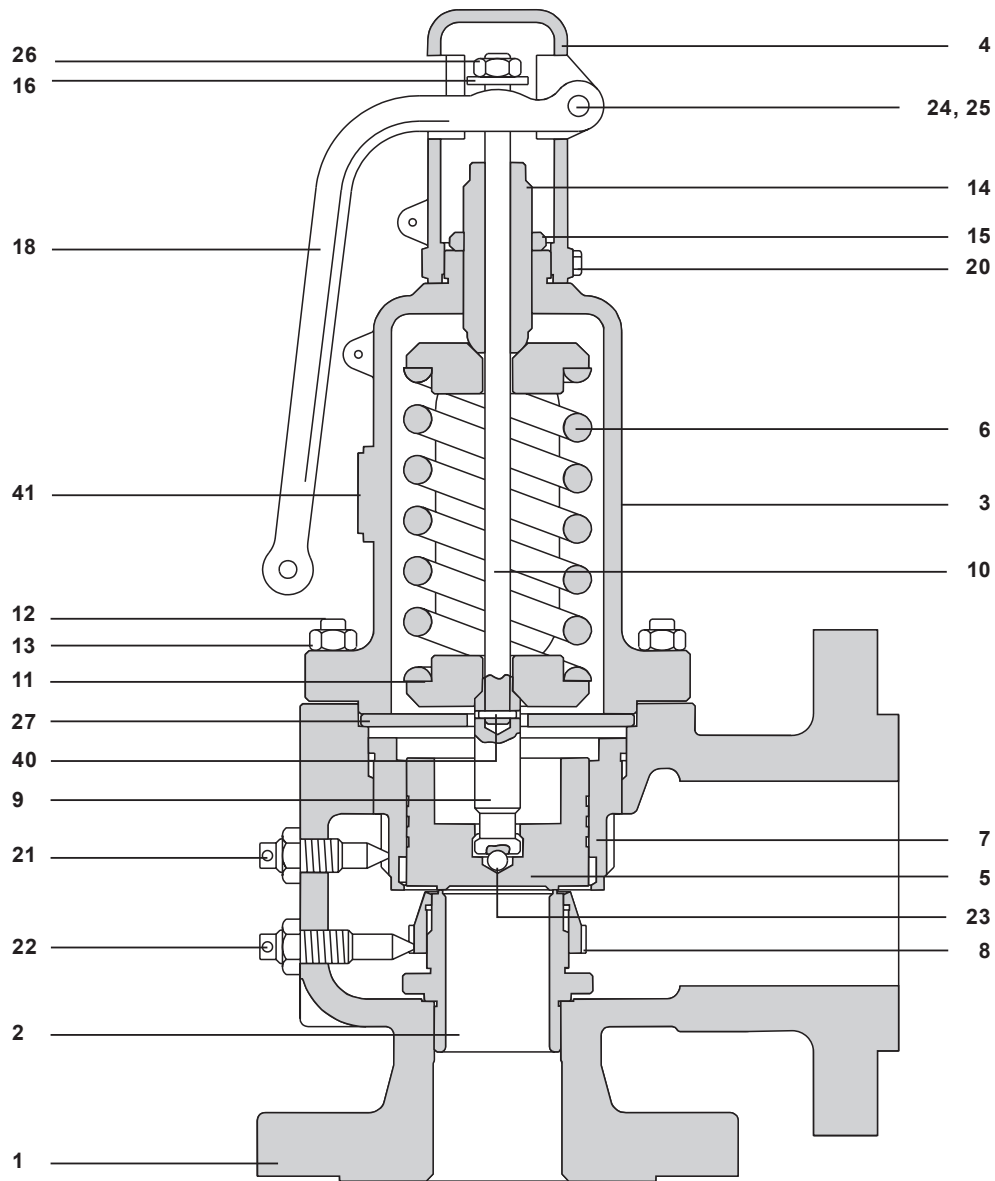

No.	Part	Material
1	Body	ASME SA 216 Gr. WCB
2	Seat	F to H orifice ASTM A479 304
		J to R orifice ASTM A351 Grade CF8
3	Bonnet	ASME SA 216 Gr. WCB
4	Cap	ASTM A126 Class B
5	Disc	F to H orifice ASTM A479 304
		J to R orifice ASTM A217 CA15
6	Spring	Chrome-vanadium alloy steel
7	Upper adjusting ring	ASTM A351 Grade CF8
8	Lower adjusting ring	ASTM A351 Grade CF8

No.	Part	Material
9	Stem (lower)	ASTM A479 Type 410
10	Stem (upper)	ASTM A479 Type 410
11	Spring washers (2 off)	ASTM A105
12	Bonnet stud	ASTM A193 Grade B7
13	Bonnet nut	ASTM A194 Grade 2H
14	Adjusting screw	ASTM A479 Type 410
15	Adjusting screw nut	Carbon steel
16	Release ring	Carbon steel
17	Lock-nuts (2 off)	Carbon steel
18	Lever	Grey iron

No.	Part	Material
20	Cap set screw	Carbon steel
21	Upper adjusting ring pin	Stainless steel
22	Lower adjusting ring pin	Stainless steel
23	Disc ball	Stainless steel
24	Pin washer	Carbon steel
25	Lever pin	Carbon steel
26	Lock-nut	Carbon steel
27	Guide plate	Carbon steel
40	Stem pin	Carbon steel
41	Name plate	Stainless steel

Dimensions, weights and orifice sizes (approximate) in inches and lbs

Valve inlet		Valve outlet		Orifice letter	A	B	C	Weight
Size	Connection	Size	Connection					
1½"	ANSI 300	2"	ANSI 150	F	4.25	4.5	15.7	31
1½"	ANSI 300	2"	ANSI 150	G	4.25	4.5	15.7	31
1½"	ANSI 300	2½"	ANSI 150	H	4.90	4.8	16.2	46
1½"	ANSI 300	2½"	ANSI 150	J	4.90	4.8	16.2	46
2"	ANSI 300	3"	ANSI 150	K	5.60	5.1	18.5	62
2½"	ANSI 300	4"	ANSI 150	L	6.40	6.1	20.1	90
3"	ANSI 300	4"	ANSI 150	M	6.50	6.5	25.0	117
4"	ANSI 300	6"	ANSI 150	N	7.50	7.2	26.7	198
4"	ANSI 300	6"	ANSI 150	P	8.30	7.1	28.7	212
6"	ANSI 300	8"	ANSI 150	Q	9.40	9.9	34.8	384
6"	ANSI 300	8"	ANSI 150	R	10.00	10.9	43.9	633

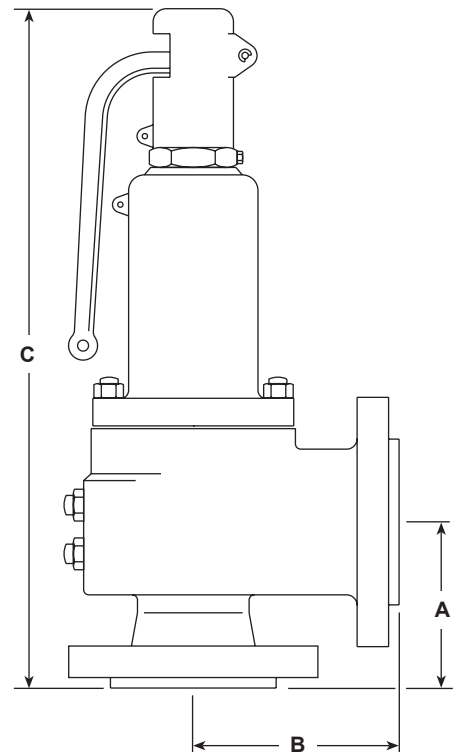

Installation

Safety valves must be installed in a vertical upright position and drained via connection 19.

Avoid having the operating pressure too near the safety valve set pressure. A very minimum differential of 5 psig or 10% (whichever is greater) is recommended. An even greater differential is desirable, when possible, to assure better seat tightness and valve longevity.

Avoid discharge piping where its weight is carried by the safety valve. Even though supported separately, changes in temperature alone can cause piping strain. We recommend that drip pan elbows or flexible connections be used where possible. If required, remove protective plug (19) and route to drain.

For full details on proper installation, please refer to the installation, operating and maintenance instructions, IM-S13-33.

Maintenance

Develop a regular program of visual inspection. Inspection should include checking for clogged drains, discharge pipe, and dirt build-up around the valve seat.

Test the safety valve every 6 months (depending on plant's age and condition) either by raising the system pressure to the valve's set pressure or operating the hand lever.

How to specify

To simplify selection and specifying of Spirax Sarco safety valves, use the following type numbering system. The type numbering system is ideal as the digit which comprises a specific type number has a distinct significance. The digits describe the basic valve series, materials of construction, connection type, boiler code conformance, inlet and outlet connections, orifice size and set pressure.

SV7 safety valve selection guide

Series number	SV7	SV7
Construction	4 = Cast steel	4
ASME section	V = ASME Code Section I U = ASME Code section VIII Blank = Valve without code stamp	V
Size and connection	S = 1½" ANSI 300 x 2" ANSI 150 T = 1½" ANSI 300 x 2½" ANSI 150 U = 2" ANSI 300 x 3" ANSI 150 V = 2½" ANSI 300 x 4" ANSI 150 W = 3" ANSI 300 x 4" ANSI 150 X = 4" ANSI 300 x 6" ANSI 150 Y = 6" ANSI 300 x 8" ANSI 150	X
Actual orifice area Sq. In.	F = 0.328 G = 0.537 H = 0.841 J = 1.374 K = 1.968 L = 3.054 M = 3.846 N = 4.633 P = 6.830 Q = 11.811 R = 17.123	P
Set pressure	Specify set pressure from 5 psig to 300 psig*	180

Ordering example	SV7	4	-	V	-	X	P	-	180
-------------------------	-----	---	---	---	---	---	---	---	-----

How to order

Example 1: 1 off Spirax Sarco SV74-V-XP-180 safety valve having a set pressure of 180 psig.

***Note :** R orifice, Section 1, pressure limit is 250 psig

***Note :** Set pressures below 15 psi are not ASME coded and are not certified.