



SRV66

Sanitary Pressure Reducing Valve

Description

The SRV66 is an angle pattern self-draining sanitary pressure regulating valve of all 316 type stainless steel construction suitable for use on steam, water and inert industrial gases. It is available with sanitary clamp compatible connections, requires no external pressure sensing line and has clean in place (CIP) and sterilise in place (SIP) capability.

Typical applications include: Clean steam, gas and liquid supplies to bioreactors, centrifuges, freeze dryers, sterilisers, autoclaves, process tanks, humidifiers and culinary equipment.

Valve tightness

Valve tightness is in accordance with VDI/VDE guideline 2174 (leakage rate < 0.5% of K_{Vs} value).

Standard surface finish and cleaning

Internal wetted parts - $R_a < 3.2 \mu\text{m}$ (126 μin) ultrasonically cleaned.

Available options, supplied on request at extra cost:

Polished version	For food, pharmaceutical and superclean applications with surface roughness: $R_a \leq 0.25, 0.4$ or $0.8 \mu\text{m}$ A351 CF8 (9.8, 15.7, or 31.4 μin)
Viton (FEPM)	Elastomer soft seat
	Aseptic
	ASME BPE clamp
	ASME or JIS flanges
Special connections	DIN32676 A & B clamps
	NPT screwed
	Welding spigots

Note: Other connections/constructions available upon request

Oil and grease free

FDA approved diaphragm material

Certification options

The following are available at an additional cost:

- EN10204 3.1 Documentation Pack
- FDA approval for wetted parts
- USP class VI approval for wetted parts
- Surface roughness certificate for wetted surfaces
- Confirmation that the parts in this product contain only animal-free derivatives

Note: All certification/inspection requirements must be stated at the time of order placement.

Sizes and connections

DN15, DN20, DN25, DN32, DN40, and DN50 ($\frac{1}{2}$ ", $\frac{3}{4}$ ", 1", $1\frac{1}{4}$ ", $1\frac{1}{2}$ ", and 2")

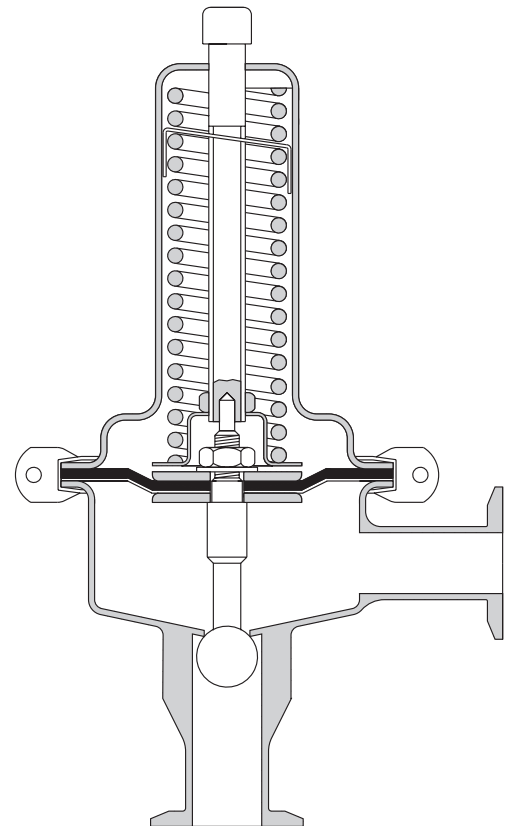

Pressure/temperature limits

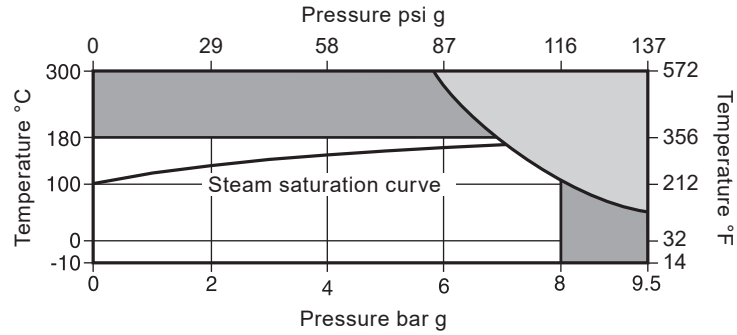

- The product **must not** be used in this region.
- The product should not be used in this region or beyond its operating range as damage to the internals may occur.

Body design conditions	Inlet	PN10
	Outlet	see 'Pressure setting range' below
Maximum design pressure	9.5 bar @ 50 °C (137 psi g @ 122 °F)	
Maximum design temperature	300 °C @ 5.8 bar (572 °F @ 84 psi g)	
Minimum design temperature	-10 °C (14 °F)	
Maximum operating temperature	180 °C (356 °F)	
Maximum operating pressure (inlet)	8 bar g (116 psi g)	
Minimum operating temperature	-10 °C (14 °F)	
Designed for a maximum cold hydraulic test pressure of	15.2 bar g (220 psi g)	

Pressure setting range

Size	DN15 - DN50 (½" - 2")		
Inlet/outlet rating	PN10/PN2.5	PN10/PN6	PN10/PN10
Spring range	0.3 - 1.1 bar g (4.3 - 15.9 psi g)	0.8 - 2.5 bar g (11.6 - 36.2 psi g)	1.0 - 5.0 bar g (14.5 - 72.5 psi g)
Maximum permitted outlet pressure = 1.5 times set pressure			

K_V values

To maximise the control accuracy (especially for large load variations) use the K_V values given at 20% offset. For safety valve sizing use the maximum K_V values.

Valve size	DN15 (½")	DN20 (¾")	DN25 (1")	DN32 (1¼")	DN40 (1½")	DN50 (2")
K _V at 20% offset	2.0	3.0	3.5	4.0	4.5	5.2
Maximum K _V	2.6	3.9	4.6	5.2	5.9	6.8

For conversions:

$$C_V \text{ (UK)} = K_V \times 0.963$$

$$C_V \text{ (US)} = K_V \times 1.156$$

Sizing

The required K_V can be calculated from the following formulae:

where:

\dot{m}_s = Steam mass flow (kg/h)

\dot{V} = Liquid volume flow (m³/h)

\dot{V}_g = Gas flow at standard conditions: 0 °C @ 1.013 bar a (m³/h)

P_1 = Upstream pressure (bar absolute)

P_2 = Downstream pressure (bar absolute)

χ = $\frac{P_1 - P_2}{P_1}$ (pressure drop factor)

S = Specific gravity

T = Absolute average gas temperature (Kelvin = °C + 273)

Critical pressure drop: $P_2 \leq 0.58 P_1$

$$K_V = \frac{\dot{m}_s}{12 P_1}$$

Steam

Non-critical pressure drop: $P_2 \geq 0.58 P_1$

$$K_V = \frac{\dot{m}_s}{12 P_1 \sqrt{1 - 5.67 (0.42 - \chi)^2}}$$

Gas

$$K_V = \frac{\dot{V}_g}{287} \sqrt{\frac{ST}{(P_1 - P_2)(P_1 + P_2)}}$$

Liquid

$$K_V = \dot{V} \sqrt{\frac{S}{P_1 - P_2}}$$

Calculating the K_V and selecting a suitable valve

Using your maximum flowrate and smallest differential pressure ($P_1 - P_2$), calculate the required K_V from one of the above formulae. Select a valve K_V that is 30% greater than the calculated K_V . The optimum working range of the selected valve should ideally be within the range of 10 to 70% of its K_V .

Recommended fluid velocities

Steam	Saturated	10 to 40 m/s (32.8 to 131.2 ft/s)
	Superheated	15 to 60 m/s (49.2 to 196.8 ft/s)
Gas	up to 2 bar g (29 psi g)	2 to 10 m/s (6.5 to 32.8 ft/s)
	above 2 bar g (29 psi g)	5 to 40 m/s (16.4 to 131.2 ft/s)
Liquids		1 to 5 m/s (3.2 to 16.4 ft/s)

Materials

No.	Part	Material	
1	Body (integral seat)	Stainless steel	1.4404 (316L)
2	Main valve	Stainless steel	1.4404 (316L)
3	Spring housing	Stainless steel	1.4404 (316L)
4	Adjustment screw	Stainless steel	BS 6105 A4 70
5	Spring	Stainless steel	1.4301 (304)
6	Spring clip	Stainless steel	1.4301 (304)
7	Diaphragm nut	Stainless steel	BS 6105 A4 70
8	Diaphragm plate	Stainless steel	1.4404 (316L)
9	'V' band clamp	Stainless steel	1.4404 (316L)
10	Diaphragm	FPM (Viton)/ PTFE	
11	'O' ring	PTFE	
12	'V' band clamp screw	Stainless steel	BS 6105 A4 70

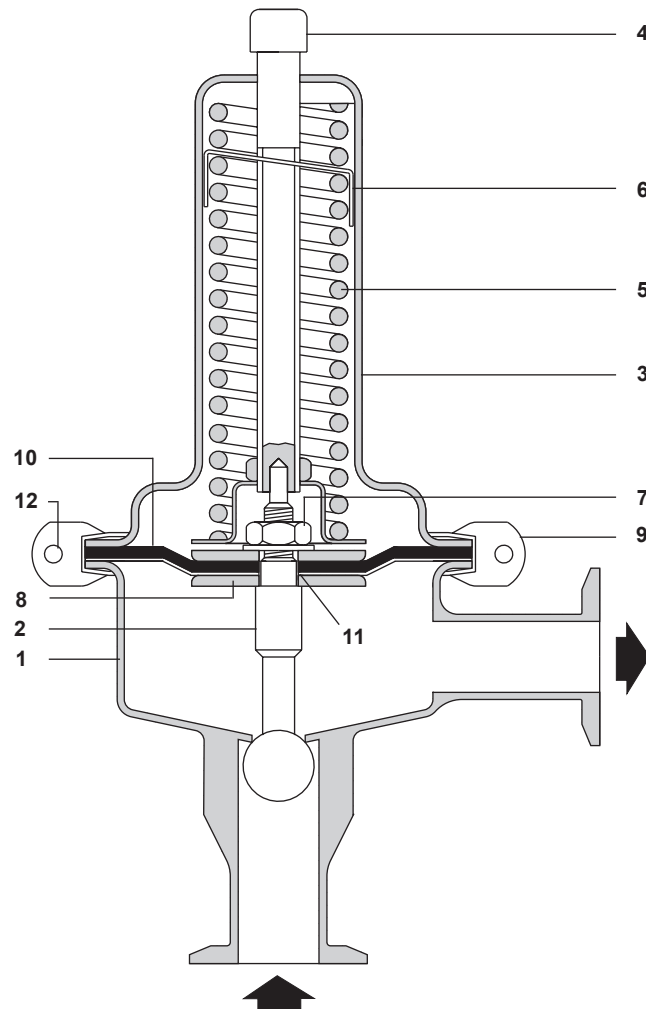

Dimensions/Weights (approximate) in mm and kg (in and lbs)

Pressure range	Size	A	B	C	Weight
1.0 to 5.0 bar and 08. to 2.5 bar (14.5 to 72.5 psi and 11.6 to 36.2 psi)	DN15 - DN25 (½" - 1")	90 (3.5)	138 (5.4)	200 (7.8)	2.0 (4.4)
	DN32 - DN40 (1¼" - 1½")	120 (4.7)	138 (5.4)	200 (7.8)	2.5 (5.5)
	DN50 (2")	120 (4.7)	138 (5.4)	200 (7.8)	3.0 (6.6)
0.3 to 1.1 bar (4.3 to 15.9 psi)	DN15 - DN25 (½" - 1")	120 (4.7)	200 (7.8)	200 (7.8)	3.0 (6.6)
	DN32 - DN40 (1¼" - 1½")	120 (4.7)	200 (7.8)	200 (7.8)	3.5 (7.7)
	DN50 (2")	120 (4.7)	200 (7.8)	200 (7.8)	4.0 (8.8)

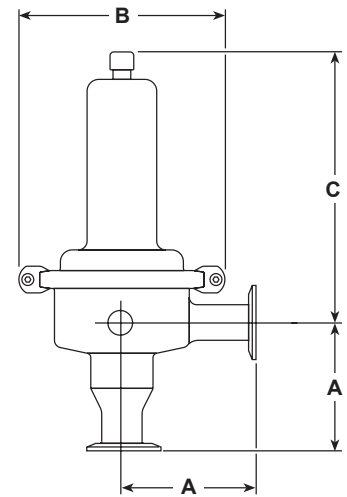

Safety information, installation and maintenance

For full details see the Installation and Maintenance Instructions (IM-P186-09) supplied with the product.

Installation note:

The SRV66 should always be fitted with the inlet vertical and the spring housing directly above the valve.

How to order example

1 off Spirax Sarco DN25 SRV66 direct acting sanitary pressure reducing valve having a pressure range of 1 – 5 bar g a PN10/PN6 rating, FPM diaphragm and ISO 2852 sanitary clamp compatible connections.

Spare parts

The spare parts available are detailed below. No other parts are supplied as spares.

Available spares

Diaphragm and 'O' ring

10, 11

How to order spares

Always order spares by using the description given in the column headed 'Available spares' and state the size, model and pressure range.

Example: 1 - Diaphragm and 'O' ring for a Spirax Sarco DN25 SRV66 direct acting pressure reducing valve having a pressure range of 1 - 5 bar, a PN10/PN6 rating and an FPM diaphragm.

