



# Stainless Steel Direct Operated Pressure Regulator SRV461/463

## Description

Types SRV461/463 Direct Acting Pressure Reducing Valve with non-rising adjustment screw, O-ring soft seal on valve plug for tight ANSI Class VI shutoff, and 316 Ti stainless steel construction for wetted parts.

Model	SRV461	SRV463
Sizes	1/2", 3/4"* (DN15, DN20, DN25, DN32, DN40, DN50)	
Plug connections	NPT	ANSI 150
Construction	316 Ti Stainless Steel, EPDM	Diaphragm, TFE O-ring Seal
Options	BSP Connections	DIN PN16 or BS4504 flanges
	SRV461S and SRV463S for Hydrocarbon Service - Consult Factory	
	Non-Standard Pressure Ranges	

\* 3/4" is flanged only

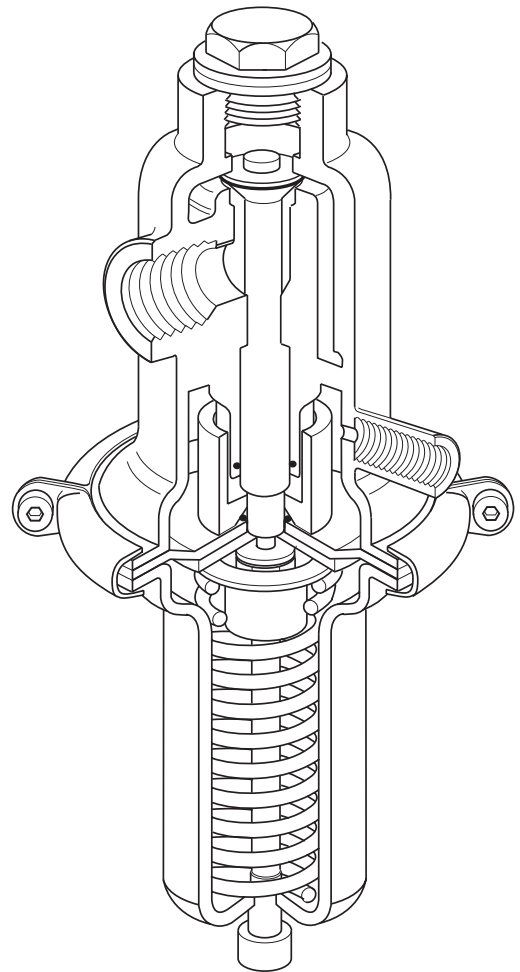

## Typical applications

Clean steam, gas, and liquid supplies to bioreactors, centrifuges, freeze dryers (lyophilizers), sterilizers, autoclaves, process tanks, production suites, humidifiers, and culinary equipment.

## Limiting operating conditions

Maximum operating pressure (PMO)	174 psi g (12 bar g)	
Maximum operating temperature	Steam service:	374 °F (190 °C)
	Liquid and gas service:	266 °F (130 °C) at all operating pressures

## Pressure shell design conditions

PMA	Maximum allowable pressure	220 psi g/0-122 °F	(15 bar g/0-50 °C)
		187 psi g/302 °F	(13 bar g/150 °C)
		174 psi g/374 °F	(12 bar g/190 °C)
TMA	Maximum allowable temperature	374 °F/0-174 psi g	(190 °C/0-12 bar g)
Pressure ranges		4 – 16 psi	(0.3 – 1.1 bar)
		12 – 36 psi	(0.8 – 2.5 bar)
		30 – 75 psi	(2.1 – 5.2 bar)

## Materials

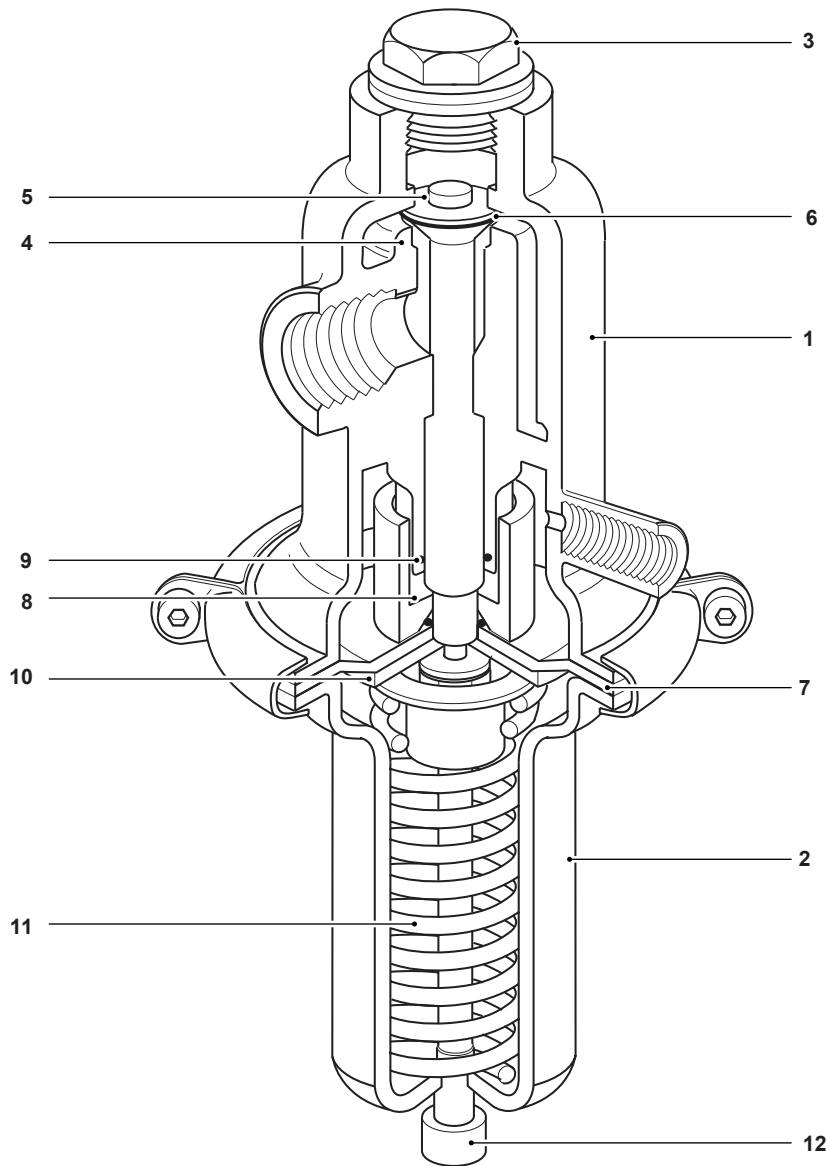

No.	Part	Material	Werkstoff no.	AISI equivalent*
1	Body	Stainless steel	1.4571	316 Ti
2	Spring housing	Stainless steel	1.4404	316L
3	Cap	Stainless steel	1.4571	316 Ti
4	Valve seat	Stainless steel	1.4571	316 Ti
5	Valve plug	Stainless steel	1.4571	316 Ti
6	O-Ring seal	TFE		
7	Diaphragm	EPDM		
8	Piston	Stainless steel	1.4571	316 Ti
9	O-Ring	EPDM		
10	Top spring plate	Stainless steel	1.4571	316 Ti
11	Spring	Stainless steel	1.4310	301
12	Adjustment screw	Stainless steel	1.4571	316 Ti

\* not direct equivalents, nearest AISI specification is given.

## Capacities

Capacities can be calculated from 20% offset (droop) values opposite

Size		Cv	Kv
½"	DN15	4.7	4
¾"	DN20	5.9	5
1"	DN25	7.0	6
1¼"	DN32	14.0	12
1½"	DN40	18.7	16
2"	DN50	21.1	18

## Sizing notes

- 1) Maximum capacities can be obtained only at the upper end of each pressure range. Therefore, to ensure quoted capacities always select lowest pressure range option compatible with required downstream pressure.
- 2) Because of valve droop characteristics, it is recommended that only 80% of the "fully open capacity indices" be used for sizing.
- 3) Required Cv's can be calculated from the following formulae:

### For steam:

Establish whether the flow is critical or non-critical, and calculate the required Cv using one of the following formula:

### For liquids

$$Cv = \text{GPM} \sqrt{\frac{\text{Sp. Gr}}{\text{Pressure Drop, psi}}}$$

Where

Sp. Gr. Water = 1

GPM = Gallons per minute

### For steam (saturated)

#### a. Critical Flow

When  $\Delta P$  is greater than  $F_L^2 (P_1/2)$

$$Cv = \frac{W}{1.83 F_L P_1}$$

#### b. Noncritical Flow

When  $\Delta P$  is less than  $F_L^2 (P_1/2)$

$$Cv = \frac{W}{2.1 \sqrt{\Delta P} (P_1 + P_2)}$$

#### Where:

$P_1$  = Inlet Pressure psi a

$P_2$  = Outlet Pressure psi a

W = Capacity lb/hr

$F_L$  = Pressure Recovery Factor  
(.9 on globe pattern valves for flow to open)  
(.85 on globe pattern valves for flow to close)

## Sample specification

Stainless steel direct acting pressure reducing valves shall be diaphragm actuated with all 316Ti grade body and a soft O-ring seal for ANSI Class VI shutoff.

Pressure setting on valves shall be adjustable while in service with maximum capacities rated for droop not to exceed 20%.

Valve body shall be of packless design.

Spirax Sarco SRV461 (screwed) SRV463 (flanged).

**Dimensions (approximate) in inches (mm)**

Size	A	B	C	D		E	
				4-16	12-36 (30-75)	4-16	12-36 (30-75)
1/2"	3.4 (86)	5.1 (130)	3.0 (76)	11.8 (300)	9.3 (236)	7.9 (201)	5.4 (138)
3/4"		5.9 (150)	3.0 (76)				
1"	3.4 (86)	6.3 (160)	3.0 (76)				
1 1/4"	5.1 (130)	7.1 (180)	3.5 (29)				
1 1/2"	5.7 (145)	7.9 (201)					
2"	7.3 (185)	9.1 (231)					

**Weights (approximate) in lbs (kg)**

setting ranges		screwed		flanged	
psi	bar	1/2"-1"	1 1/4"-2"	1/2"-1"	1 1/4"-2"
4-16	0.3-1.1	13.5 (6.1)	15.4 (7)	17.4 (7.9)	24.2 (11.0)
12-36	0.8-2.5	6.5 (2.9)	8.8 (4.0)	10.8 (4.9)	13.2 (6.0)
30-75	2.1-5.1				

See Installation & Maintenance Instructions IMI 3.110 supplied with each valve.

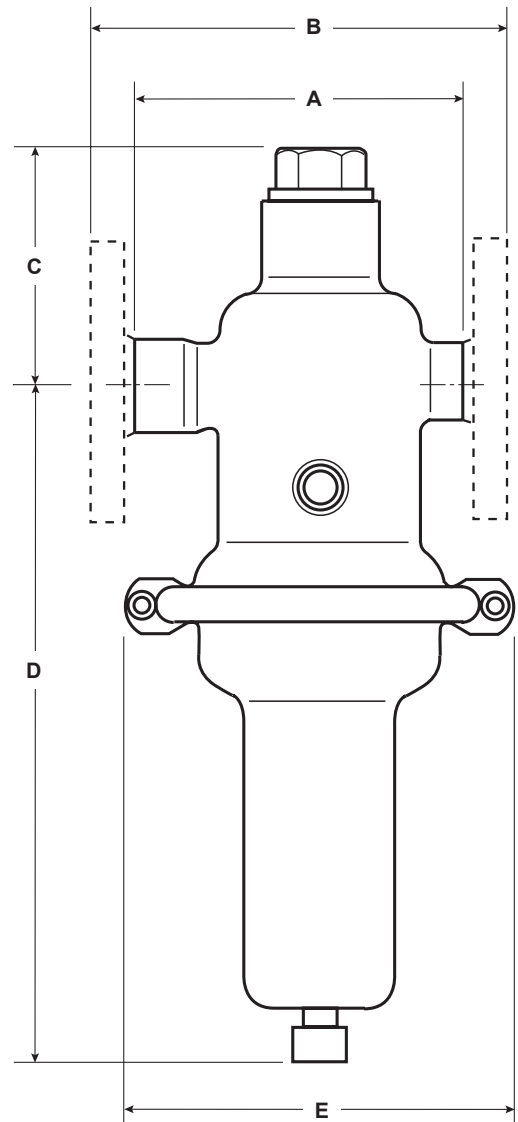

**Maintenance**

This product can be maintained without disturbing the piping connections. Complete isolation of the valve from supply is required before any servicing is performed.

The valve should be disassembled periodically for inspection and cleaning of the valve head and seat.

Worn or damaged parts should be replaced. Please refer to Spare Parts list for replacement parts. Complete installation and maintenance instructions are given in IMI 3.110 which accompanies the product.

## Spare parts and repair kit

Standard spare parts are those shown numbered in the diagram. Additional spares may be available upon request.

Always order spares by using the description in the first column, and by stating size, type, pressure range and valve seal type for the reducing valve.

**Valves with pressure ranges  
12-36 psi and 30-75 psi  
(0.82-2.48 bar and 2.06-5.17 bar)**

**Valves with pressure range  
4-16 psi  
(0.27 bar)**

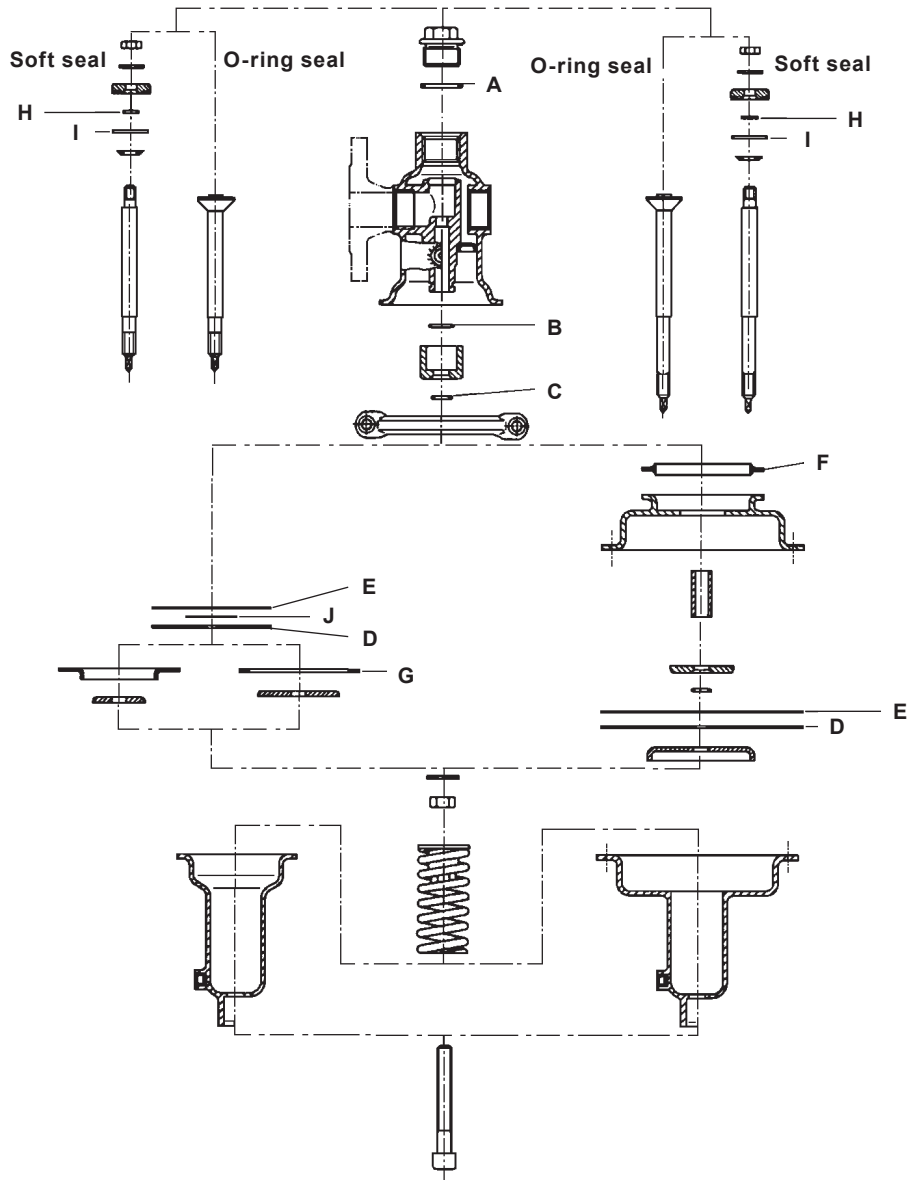

Repair kit – SRV461/463	½"-1"	DN15-25	A, B, C, D, E, F, G
Repair kit – SRV461S/463S	½"-1"	DN15-25	A, B, C, D, E, F, G, H, I
Repair kit – SRV461/463	1¼"-2"	DN32-50	A, B, C, D, E, F, G, J
Repair kit – SRV461S/463S	1¼"-2"	DN32-50	A, B, C, D, E, F, G, H, I, J
Item J—Sizes	1¼" and larger only		