

spirax sarco

SPIRA-tec® Sensor Chambers ST14, ST16, ST17

The Sensor Chamber is installed upstream of the steam trap as part of the SPIRA-tec® steam trap fault detection system. The chamber is supplied with a drilled and tapped connection for the SPIRA-tec® sensor (standard or waterlogging) which is supplied separately (see other side). Steam trap status is indicated on a portable indicator (Type 30) or remote monitor (R16C & R16E).

Model	ST14	ST16	ST17
PMO	464 psig		
Sizes	1/2" to 2"	1/2", 3/4", 1"	
Connections	NPT		
Construction	Steel	Stainless Steel	Ductile Iron
Options	SW Connections	SW Connections ANSI 150 & 300 Flanges	

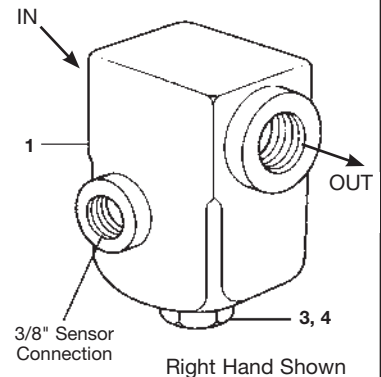

Limiting Operating Conditions

Max. Operating Pressure (PMO) 464 psig (32 barg)
Max. Operating Temperature (TMO) Saturated Steam Temperature

Pressure Shell Design Conditions

PMA	580 psig/up to 248°F	40 barg/up to 120°C
Max. allowable pressure	464 psig/482°F	32 barg/250°C
	319 psig/662°F (ST17 only)	22 barg/350°C
	304 psig/752°F (ST14&ST16)	21 barg/400°C

TMA	662°F/0-319 psig (ST17 only)	350°C/0-22 barg
Max. allowable temperature	752°F/0-304 psig (ST16 & ST14)	400°C/0-21 barg

Sample Specification

SPIRA-tec® steam leak detection system shall consist of an in-line sensor chamber and a portable or remote indicator box and cable for test purposes.

Sensor chambers, fitted before each trap, shall have ductile iron, steel, or stainless steel bodies with screwed, socket weld or flanged connections, and incorporate a sensing element.

The hand-held indicator box shall have positive colored pass and fail lights, an internal circuit check facility. An indicator cable 4 feet long shall be provided with each box.

Optional items shall include a hand-operated remote test box for testing either a single trap or up to 12 traps, an automatic remote electronic monitoring system for up to 16 traps, a blanking plug to prevent ingress of dirt, and cable plug tails of either the push-fit type or screw-on connection style.

The system shall test for steam loss by detecting the presence or absence of condensate using the difference in conductivities of water and steam. The system shall also test for traps failed, closed or blocked by detecting temperature drops at the steam trap. Trap operation shall be indicated by a green (OK) light or a red (fail open) light, or an amber (fail closed) light on the indicator box.

Installation

The sensor chamber should be installed immediately upstream of the trap (close coupled) in a horizontal position with the direction of flow according to the arrow on the body.

Construction Materials

No.	Part	Material - ST14		Material - ST16		Material - ST17	
1	Sensor Chamber	Steel	DIN 17245 GS C25	Stainless Steel	AISI 316L	Ductile Iron	DIN 1693 GGG 40
3	Drain Plug	Stainless Steel	BS 970 431 S 29	Stainless Steel	AISI 316L	Stainless Steel	BS 970 431 S 29
4	Drain Plug	Stainless Steel	BS 1449 304 S 16	Stainless Steel	AISI 316L	Stainless Steel	BS 1449 304 S 16

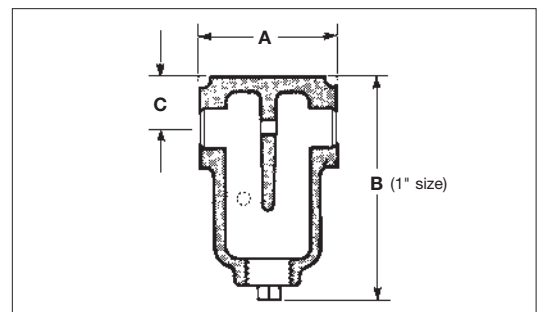

Dimensions (nominal) in inches and millimeters

ST14 & ST16	A	B	C	Weight
1/2", 3/4"	3.0	4.0	0.9	1.8 lb
	75	101	23	0.8 kg
1"	4.7	4.7	1.1	4.8 lb
	120	120	28	2.2 kg
1-1/2", 2" (ST14 only)	9.9	8.5	1.8	48.4 lb
	252	215	45	22.0 kg
ST17				
1/2", 3/4"	2.8	3.5	0.9	2.6 lb
	72	89	23	1.2 kg
1"	4.7	4.7	1.1	4.8 lb
	120	120	28	2.2 kg

Maintenance

The sensor should be removed periodically to inspect and clean the tip and insulator.

Spare Parts

Sensor and Sensor Gasket
 Blanking Plug
 Sensor gasket package of 10

Local regulation may restrict the use of this product below the conditions quoted. Limiting conditions refer to standard connections only. In the interests of development and improvement of the product, we reserve the right to change the specification.

TI-2-701-US 10.14

SPIRA-tec® Sensor Chambers

ST14, ST16, ST17

SPIRA-tec® sensor assemblies are installed into the sensor chamber (see other side) for detection of condensate and temperature drops at the steam trap. This indicates where the steam trap is leaking steam or is failed, closed or blocked.

Model	Standard	Waterlogging
Connections	3/8" BSP	
Construction	Stainless Steel	
Type	Conductivity	Conductivity & Temperature
Options	Plug Tail Assemblies (PT1, PT2, or PT3)	

Limiting Operating Conditions

Max. Operating Pressure (PMO) 464 psig (32 barg)
 Max. Operating Temperature (TMO) Saturated Steam Temperature

Sample Specification

Standard Sensor:

Sensor shall be of stainless steel construction with suitable insulator. The sensor shall be capable of determining different conductivities associated with steam and condensate.

Waterlogging Sensor:

Sensor shall be of stainless steel construction with suitable insulator. The sensor shall be capable of determining different conductivities associated with steam and condensate. The sensor shall also detect temperature drops associated with steam traps that fail closed, are blocked, or not in use. Sensor shall be made with plug tail on right hand or left hand side.

Installation

The sensor is installed into the side connection on the SPIRA-tec® sensor chamber. Chamber mounted upstream of trap as close as possible.

Maintenance

The sensor should be removed periodically to inspect and clean the tip and insulator.

Determine sensor position:

If you were to straddle the pipe facing in the direction of flow, right hand sensor would be on right side and left hand on your left side.

Note: You must order sensor separately. Chamber does not have sensor installed when supplied

Sensor types:

SSLI Steam leakage for use output only with type 30, R1C and R16C

WLSI Steam leakage and water logging for use with R1C only.

WLSI with diode steam leakage and water logging for use with R16C only.

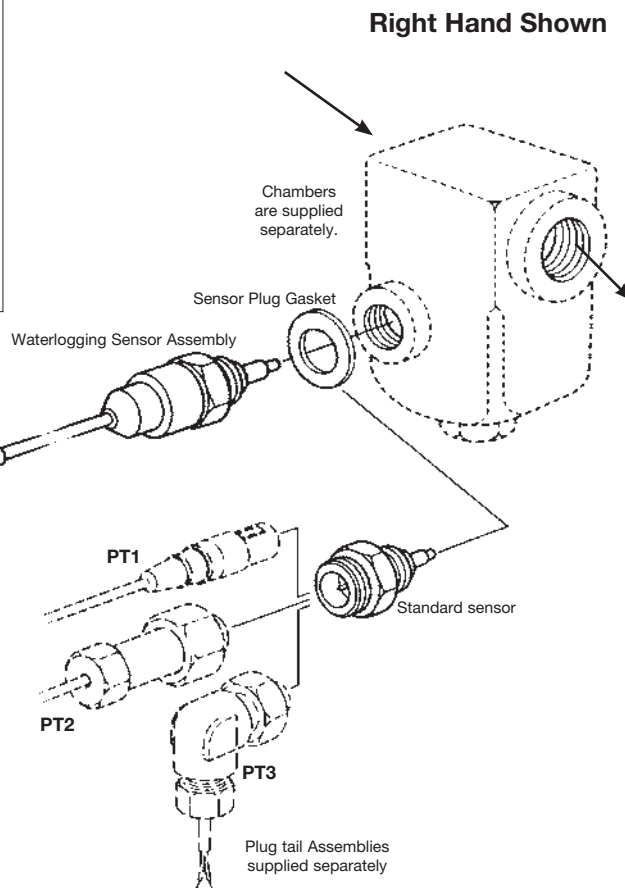

Spiratec products shall not be used in hazardous areas and explosive atmospheres.