

spirax /sarco®

SP2 Electropneumatic Smart Valve Positioner

Description

The SP2 smart valve positioner can be loop powered from a 4-20 mA input signal or independently powered to provide accurate adaptive positional control of pneumatic linear actuated valves. Precise control is maintained through valve position feedback that automatically varies the pneumatic output pressure to overcome the effects of stem friction and flow forces to maintain desired valve position. Indication of valve position is provided through a rotating travel indicator plus continuous digital display of % travel. The SP2 includes many smart functions that can be fully programmed through menu driven software using an integral keypad and LCD alphanumeric data. Valve commissioning is simplified through an autostroke routine and LCD data of programming status, software travel switch status, mA input signal and valve diagnostics data. The SP2 is supplied with a IEC 60534-6-1 standard mounting kit for attachment to yoke or pillar mounted actuators.

Applications

The SP2 can be used with the following pneumatic actuators: PN1000/2000, 3000/4000, 5000/6000

Technical data

| | |
|-------------------------------------|---|
| Input signal range | 4 - 20 mA nominal |
| Minimum input signal (loop powered) | 3.6 mA |
| Supply pressure | 20 psig (1.4 barg) minimum - 85 psig (6 barg) maximum, oil, water and dust free (to DIN / IEC60770) |
| Output pressure | 0 to 100% supply pressure |
| Stroke range | .4" to 4.0" (10 mm to 100 mm) |
| Action | Single action / fail vent |
| Operating temperature | 14° to 175°F (-10°C to +80°C) |
| Maximum air flow | 141 ft ³ /h at 20 psig (4.5 normal m ³ / h at 1.4 barg) 388 ft ³ /h at 85 psig (11 normal m ³ / h at 6 barg) |
| Steady state air consumption | Less than 1.2 ft ³ / h (0.035 normal m ³ / h) |
| Air connections | Screwed 1/4" NPT |
| Cable gland | Pg 13.5 |
| Electrical connections | Spring clamp terminals for 0.2 to 1.5 mm• wire |
| Enclosure rating | IP65 |
| Characteristics | Linear, Equal % (ratio 1:50) or Fast opening (ratio 50:1) |
| Resolution (maximum) | 8000 steps |
| Scan time | 10 ms |
| Options | Individually isolated and externally powered |
| Front cover | Hinged with security tag facility |
| Shipping weight | 10 lb (3.2 kg) |

Materials

| Part | Material | Finish |
|----------------|--------------------------------|---------------------------------|
| Case and cover | Die cast Aluminum | Anti-corrosive paint to RAL5010 |
| Linkage kit | Stainless steel / plated steel | |

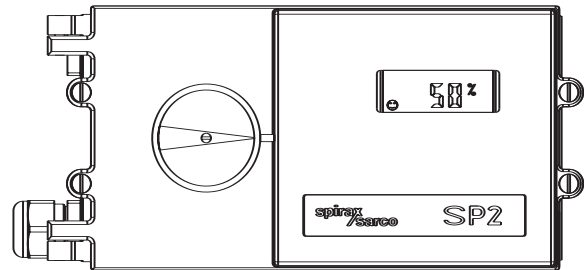

SP2 with front cover closed

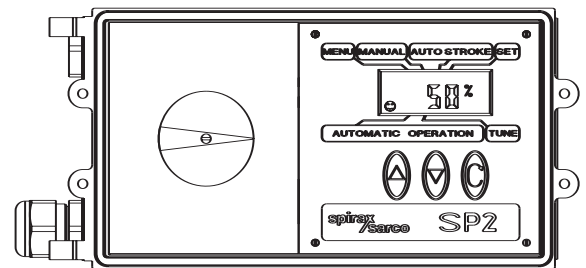

SP2 with front cover removed

Programmable functions

| | |
|---------------------|--|
| Autostroke | Automatic commissioning routine |
| Valve type | 2-port or 3-port |
| % travel | Selectable 0 - 100% or 100% - 0% depending on valve / actuator configuration |
| Control action | Direct or reverse action (4-20 or 20-4mA) |
| Travel limits | Setting of minimum and maximum travel limits |
| Signal span | 4-20 mA or split ranged (minimum span 4 mA) |
| Deadband | Positional accuracy (minimum 0.2% to max. 10% of valve travel) |
| Tight shut-off | Fully vent or inflate at preset input signals |
| Characteristic | Linear, = % or fast opening input signal to valve travel relationship |
| Travel time | Slows down valve opening or closing |
| Travel switches | Software configured travel switch setting (range 0 - 100%) |
| Reset | Resets all programmed values |
| Calibrate | Centering of feedback potentiometer span |
| Input signal | Visualisation of input mA signal |
| Auto operation/vent | Option of automatic operation or vent (actuator) whilst reprogramming |
| Data logging | Diagnostic record of total number of valve strokes and completed hours run time. |

SP2 Electropneumatic Smart Valve Positioner

Dimensions approximate in inches (mm)

| A | B | C | D | E | F |
|----------|-----------|----------|-----------|-----------|----------|
| 1.2 (32) | 7.6 (195) | 1.6 (41) | 3.9 (100) | 6.5 (166) | 3.8 (98) |

Options

Can be supplied fitted or may be fitted at a later date.

| | |
|----------------------------------|--|
| Software travel switches | Two software configured travel switches (1 x normally closed, 1 x normally open) |
| Vane operated proximity switches | Two Pepperl & Fuchs proximity switches plus two software travel switches (cannot be used simultaneously). |
| Gauge block with gauges | Manifold block complete with two pressure gauges (supply pressure and pressure to the actuator). Available ranges: 2 x 0 - 30 psi, 2 x 0 - 60 psi, 2 x 0 - 100 psi |
| 4-20MA Re-transmit | 4-20MA re-transmitter of valve position (requires 8-30Vdc external psu) |

Available spares

| | |
|-----------------|---|
| Pressure gauge | Pressure gauge only Available ranges: 0 to 30 psi, 0 to 60 psi, or 0 to 100 psi |
| Filter plug kit | Plug plus 3 off filters and 'O' rings |

Air supply

The SP2 smart positioner must be provided with a high quality air supply. A Spirax Sarco MPC2 filter regulator with coalescing filter or equivalent must be used. A fixing kit is available to mount the MPC2 filter regulator onto the actuator.

SP2
with gauge
block and
fixing kit
shown

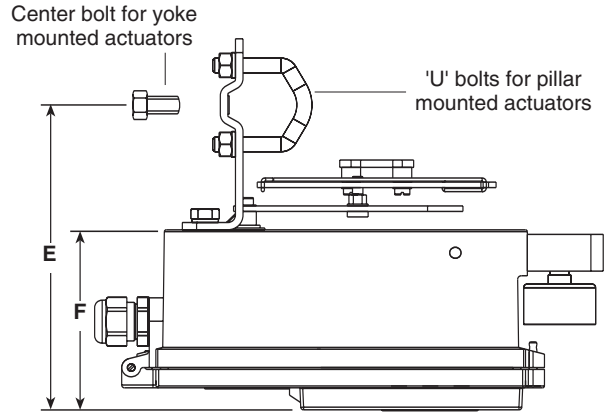
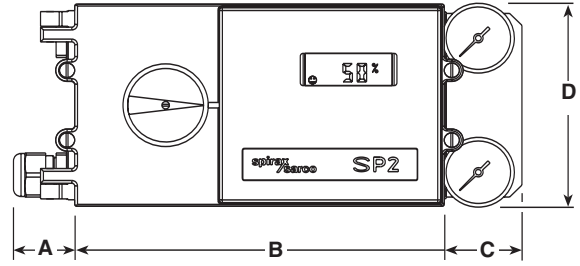
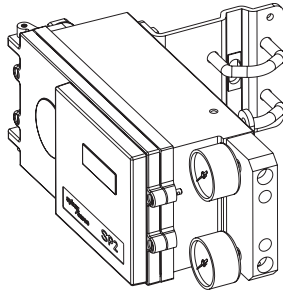

Installation

Full details are contained in the SP2 smart positioner Installation and Maintenance Instructions supplied with the product.

How to order

Examples

- 1 off SP2 electropneumatic smart positioner.
- 1 off SP2 electropneumatic smart positioner fitted with gauge block and 2 x 0 to 100 psi gauges.
- 1 off SP2 electropneumatic smart positioner fitted with 2 x software configured travel switches.

Wiring details for the main board connections

The SP2 can be loop powered using the 4 - 20 mA signal source providing a minimum signal of 3.6 mA can be maintained. If required, the SP2 can be separately powered. This is particularly useful if the input signal is likely to fall below 3.6 mA minimum or for applications that has limited voltage drop available.

Loop powered mode

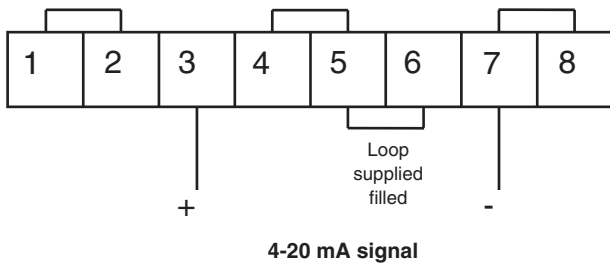

Minimum current = 3.6 mA
Maximum current = 30 mA
Voltage drop = 8-10 volts

Note: For wiring details of the options board wiring, please refer to the Installation and Maintenance Instructions.

Separate power mode

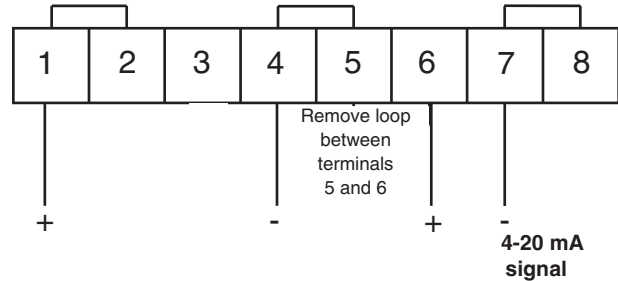

Maximum supply voltage = 36 V @ 9.6 mA
Minimum supply voltage = 18 V @ 3.6 mA
Maximum loop current = 30 mA @ 3.0 volts
Minimum loop current = 0 mA
Loop series resistance = 100 ohms
Supply to signal isolation = 50 Vac

TI-P343-17-US 03.05