



Scanner 2000 Steam Mass Flow Transmitter

Description

The Scanner 2000 steam mass flow transmitter takes its inputs from a primary flowmeter, (Gilflo or ILVA) through impulse lines. It converts the differential and static pressure into a corrected mass flowrate of saturated steam, which is accessible via the RS485 Modbus link or optionally via a 4 - 20 mA signal.

Configuration

Scanner 2000 steam mass flow transmitters are uniquely configured at the factory to work with a single, specific Gilflo or ILVA flowmeter, for a specific flow application.

For correct operation the Scanner 2000 transmitter must be installed with its allocated flowmeter. A label on the packaging gives the serial number of the matched product.

The Scanner 2000 can be configured using an RS485 equipped PC with the supplied configuration software.

Note:

A DB9 Serial RS232 to RS485 converter will otherwise be required to connect your PC to the Scanner 2000.

If your PC only has USB ports a USB to DB9 Serial port converter will be required. These are available from most electronic equipment suppliers.

Available types and approvals

Explosion proof types available:

CSA

- Class 1, Div 1, Groups B, C and D
- Type 4 Enclosure
- T6 Temperature Class

ATEX

- ATEX II 2 GD
- Ex d IIC T6 (-40°F to 158°F) or
- Ex td A21 IP68 T85C (-40°F to 158°F)
- All Scanner 2000's are compliant

Features

In head LCD providing local indication of density compensated rate and total saturated steam flow.
RS485 Modbus RTU slave functionality for remote indication, data logging and configuration.

Associated equipment

- Gilflo flowmeter
- ILVA flowmeter
- M750 flow indicator
- Optional local display

Materials

Enclosure	Cast aluminium (painted with epoxy and polyurethane)	
Body	Stainless steel	AISI 316
3-way manifold	Stainless steel	AISI 316
Fluid fill	Silicone oil	



Pipe connections

The process ports on the 3-way manifold are threaded 1/2" NPT connections at 2 1/8" (54 mm) center.

Electrical connections

3/4" NPT	Non approved and ATEX units
3/4" NPT	CSA units

Technical data

Range	Minimum 2" H ₂ O (.498 KPa)
	Maximum 200" H ₂ O (49.8 KPa)
Outputs	4 - 20 mA (expansion board required)
	RS485 Modbus RTU slave (baud rate 300 to 38.4 K)
	Solid state relay, configurable as pulse or alarm
Power supply	6 V to 30 Vdc at 31 mA
Pressure limits	155 bar
Temperature limits	-40°F to 158°F (-40°C to 70°C)
	LCD contrast is reduced below -22°F (-30°C)
Accuracy	±0.05% for Spans >10% of the URL
	±0.005 (URL/SPAN) for Spans <10% of the sensor
Enclosure rating	IEC IP68

Local regulation may restrict the use of this product below the conditions quoted. Limiting conditions refer to standard connections only.
In the interests of development and improvement of the product, we reserve the right to change the specification.

Scanner 2000 Steam Mass Flow Transmitter

Dimensions (approximate) inches (mm)

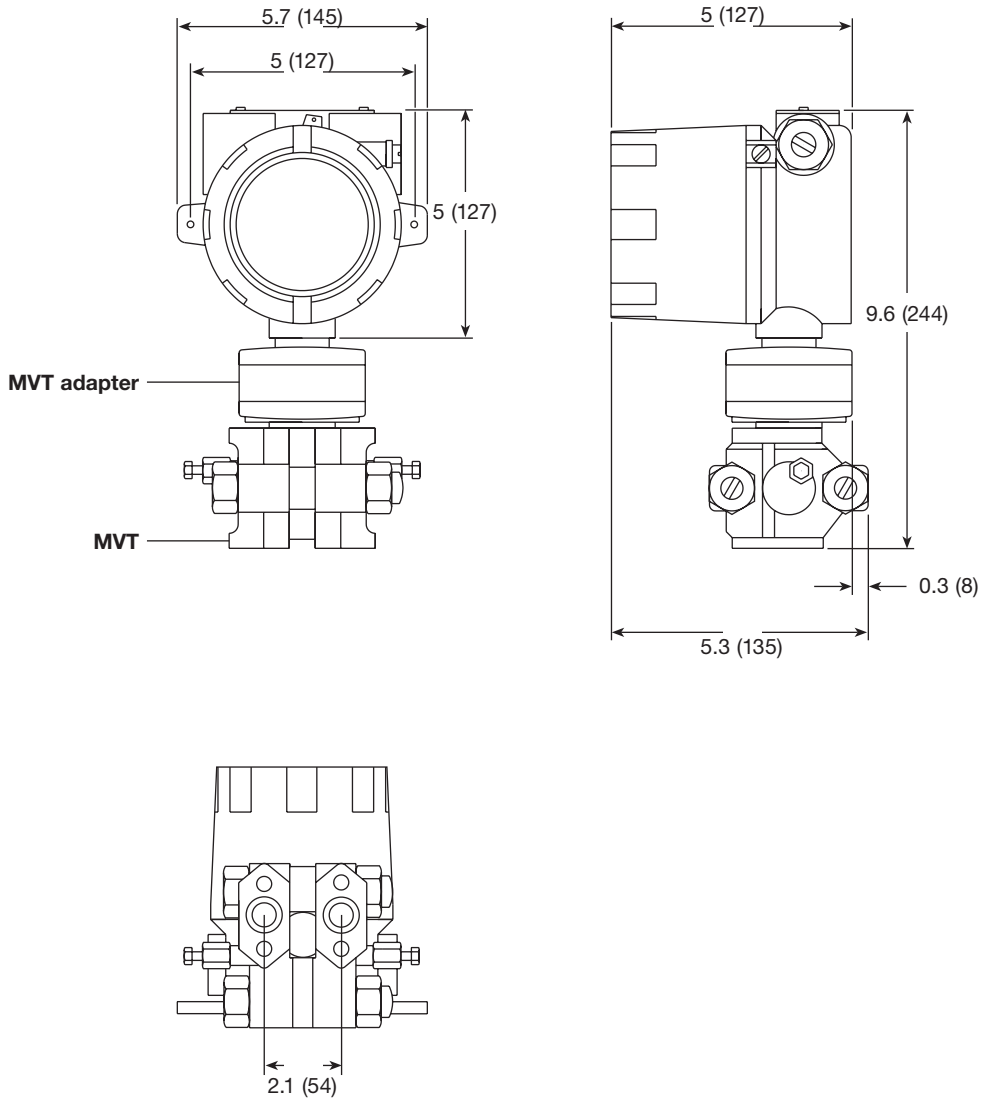

Weights (approximate) in lbs (kg)

DP transmitter	3-way manifold	Scanner 2000 assembly
11 (5)	2.2 (1)	13.2 (6)

Safety information, Installation and Maintenance

Warning: This document does not give sufficient information for safe installation of the product.

Full details are given in the Installation and Maintenance Instructions supplied with the Scanner 2000.

Scanner 2000 Steam Mass Flow Transmitter

Typical installation

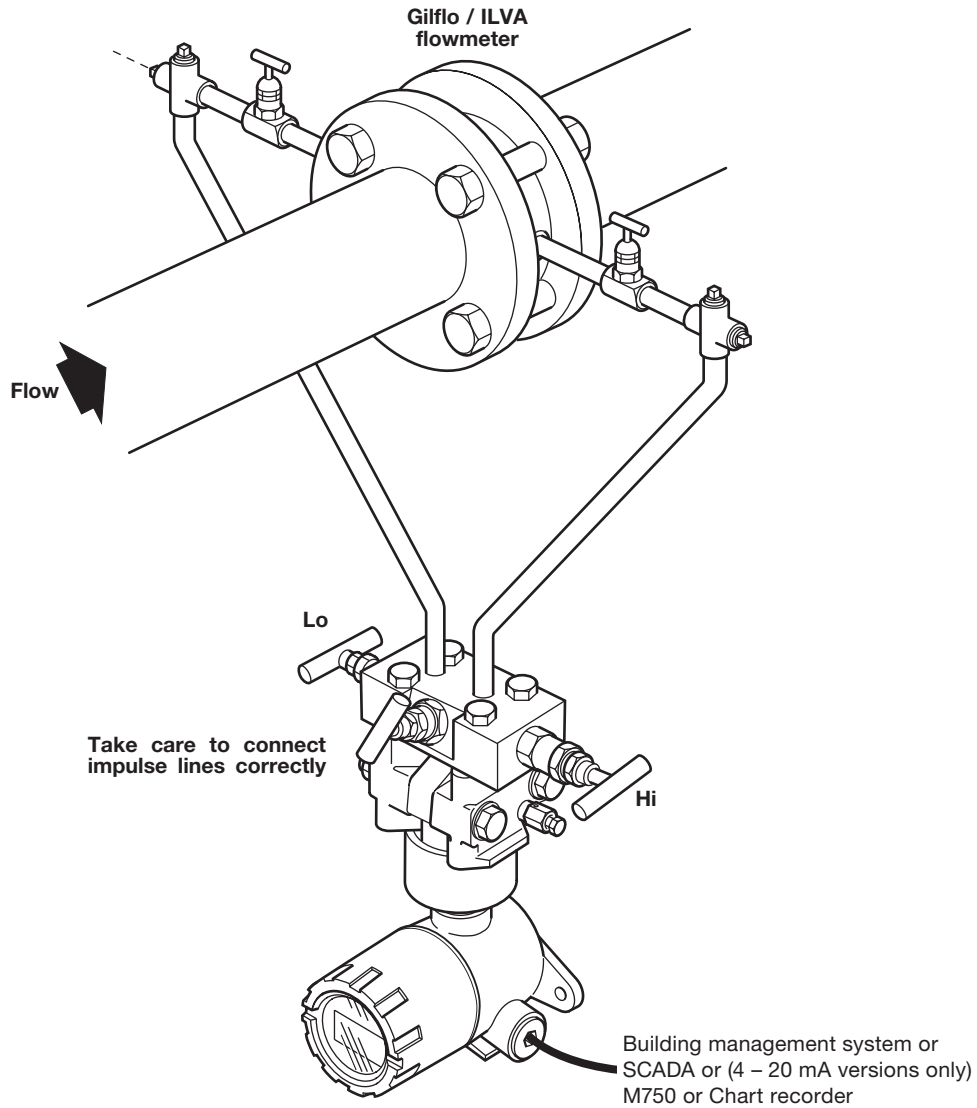

How to order

The following information will allow us to uniquely configure the Scanner 2000 for each application prior to despatch.

Parameter	Range of values	Customer requirement	Notes
Flowmeter type	Gilflo or ILVA		Specific flowmeter type
Gilflo / ILVA serial number	-		Required for existing flowmeters only
Analog output units	kg/h, lb/h, Btu/h, or kJ/h		Specific required units
Analog output scaling (4 mA)	kg/h, lb/h, Btu/h, or kJ/h		Normally zero
Analog output scaling (20 mA)	kg/h, lb/h, Btu/h, or kJ/h		Normally maximum required flowrate
Maximum range Δp	2" to 200" H ₂ O (0.498 to 49.8 KPa)		From Gilflo and ILVA sizing sheet
Steam quality (Dryness fraction)	60 to 100%		Set at 100% unless otherwise specified

Example: 1 off Scanner 2000 steam mass flow transmitter configured for use with a 3" (DN80) ILVA flowmeter passing 4400 lb/h of saturated steam at 101 psig.