



Safeguard Overheat Protection for 2 and 3 Port Temperature Control Valves

Description

The Safeguard Overheat Protection system consists of the HL10 high limit cutout with a 130 control system and one of the valves listed below. The valve is installed upstream of a heating control valve or in parallel with a cooling control valve to provide secondary overheat protection. If the temperature at the sensor exceeds the setting, the HL10 cutout is activated to close a normally open valve or open a normally closed valve. The cutout must be reset manually. Failure of the 130 control system will activate the HL10 cutout. The HL10 is available with a microswitch which may be linked to an alarm system.

Control valves

Any of the following valves can be used by attaching the valve bonnet to the coupling nut of the HL10 high limit cutout.

| | Normally open (to close w/ rise in temp) | Normally closed* (to open w/ rise in temp) |
|--------------------------|--|---|
| Two port valves | SB, KA, KB and KC valves | SBRA, KX, KY, NSRA valves |
| Three port valves | 1", 1½", 2" (DN25, DN40, DN50) TW Valves | |

* Normally closed valves must be installed in a separate bypass pipe line unimpeded by any other control valve.

130 Control system

Standard capillary tube length is 6.5 ft (2 m). Other lengths are available up to a maximum of 32 ft (10 m) in multiples of 6.5 ft (2 m). The length of capillary tubing should be kept to a minimum to avoid the system's being affected by ambient temperature.

Separable well

For correct installation, a separable well with ¾" (DN20) NPT connection is required. The sensor is held in the separable well by means of a gland nut (V) and compression ring. Wells are available in copper, mild steel and stainless steel construction.

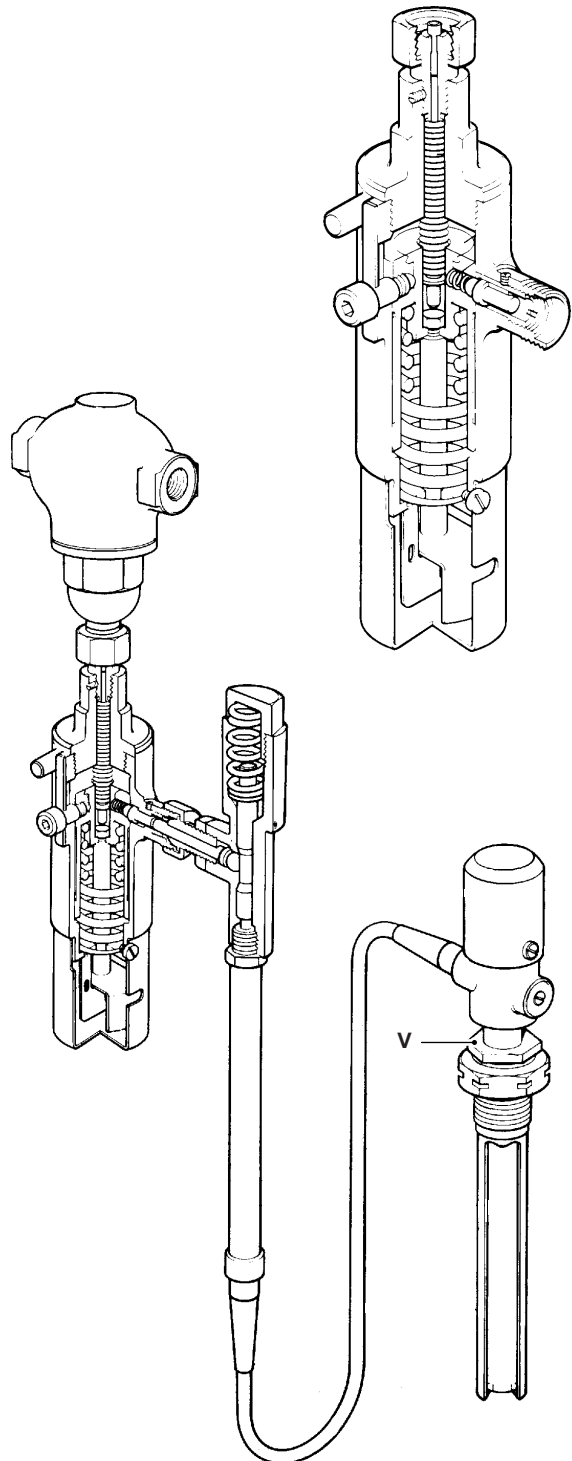

Materials

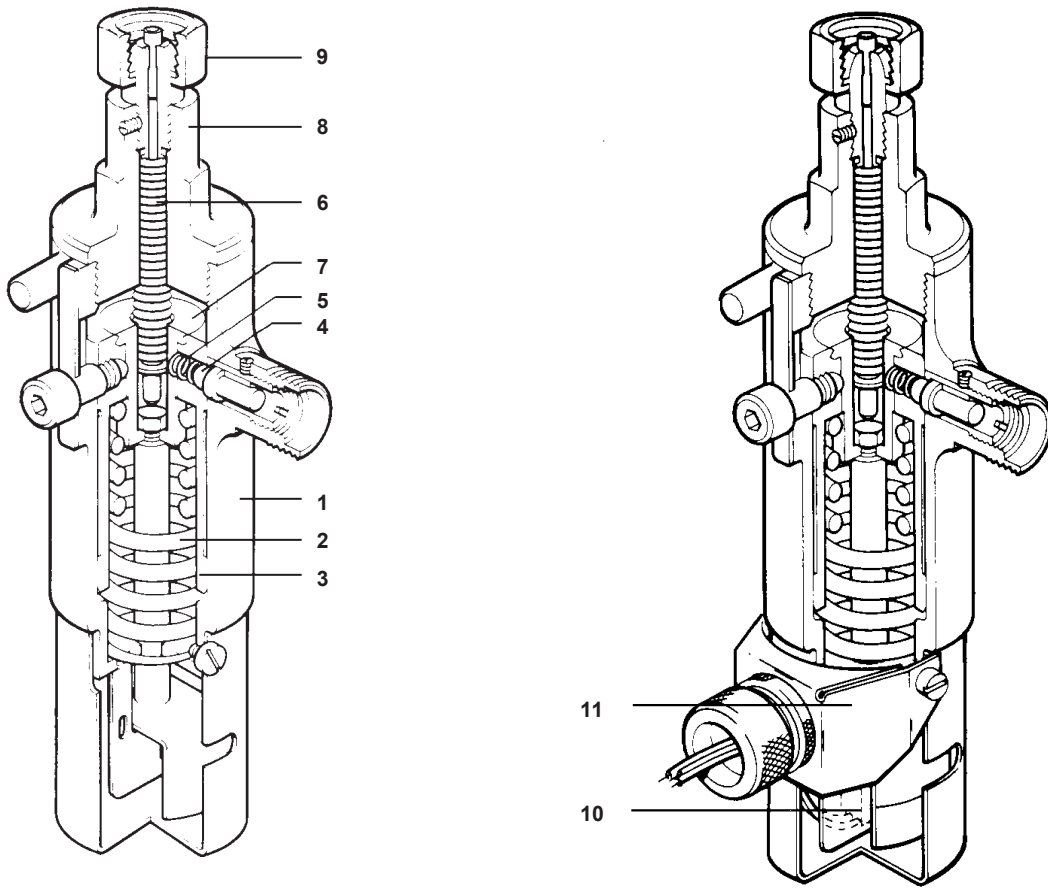

HL10
High limit cutout with micro switch

| No. | Part | Material | Material spec. | Closest equivalent |
|-----|--------------------|-----------------|----------------|---------------------|
| 1 | Body | Bronze | BS 1400 LG2 | ASTM B62 UNS C37700 |
| 2 | Main spring | Stainless Steel | | |
| 3 | Piston | Stainless Steel | | |
| 4 | Ball | Stainless Steel | | |
| 5 | Ball return spring | Stainless Steel | | |
| 6 | Bellows | Stainless Steel | | |
| 7 | Piston Insert | Stainless Steel | | |
| 8 | Bonnet | Brass | | |
| 9 | Valve coupling nut | Brass | | |
| 10 | Micro switch | | | |
| 11 | Cover | Aluminum | | |

Materials (continued)

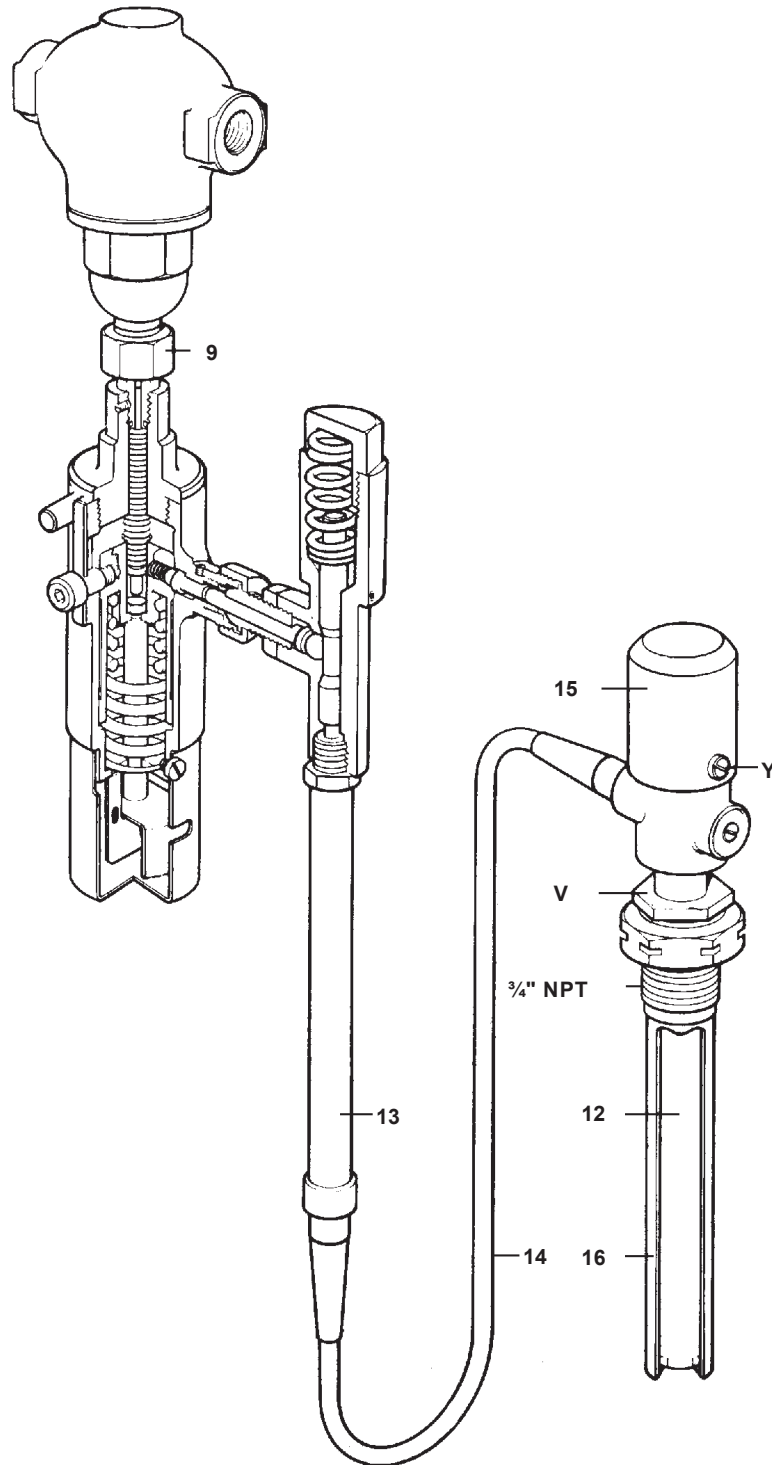

| No. | Part | Material | Material spec. | Closest equivalent |
|-----|-----------------------|---|----------------|--------------------|
| 9 | Valve coupling nut | Brass | | |
| 13 | Actuator | Brass | | |
| 14 | Capillary tube | Copper PVC covered | | |
| 15 | Adjustment head cover | Polypropylene plastic | | |
| 16 | Separable well | Stainless steel Mild steel Copper | | |

Dimensions/weights (approximate) in inches (mm) and lbs (kg)

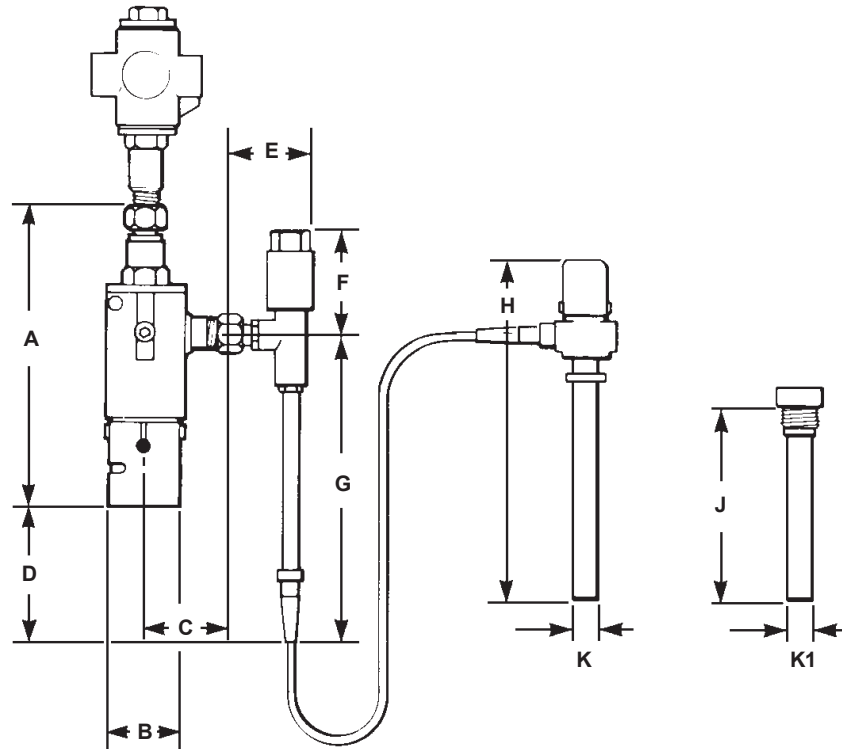

| | A | B | C | D | Weight |
|--------------|-------|------|------|------|----------|
| HL 10 | 9.3 | 2.4 | 2.4 | 3.0 | 4.8 lb |
| | (236) | (61) | (61) | (76) | (2.2 kg) |

| | E | F | G | H | J | K | K1 | Weight |
|---------------------------|------|------|-------|-------|-------|--------|------|----------|
| 130 Control System | 2.5 | 3.3 | 9.3 | 10 | 5.9 | 0.69 | 0.87 | 3.8 lb |
| | (64) | (84) | (236) | (254) | (150) | (17.5) | (22) | (1.7 kg) |

Sample specification

Spirax Sarco Safeguard (with microswitch), a spring loaded mechanism incorporating a cutout device and requiring hand reset. A brass hydraulically operated secondary overheat protection control system mounted in a separable well with PVC covered copper capillary tubing. The unit is coupled to a 2 port or 3 port valve.

Temperature setting

The system is set to operate at 140 °F (60 °C). The setting can be adjusted between 32 °F (0 °C) and 212 °F (100 °C). Full setting details are given in the Installation & Maintenance Instructions supplied with each control system and these should always be referred to. One turn of the setting screw changes the temperature by 11 °F (6 °C). On completion always replace the adjustment head cover.

Resetting

Resetting can be swiftly carried out by using a lever between the two lugs L and M.

Before resetting, it is most important to allow the equipment to cool and to remedy the cause of overheating.

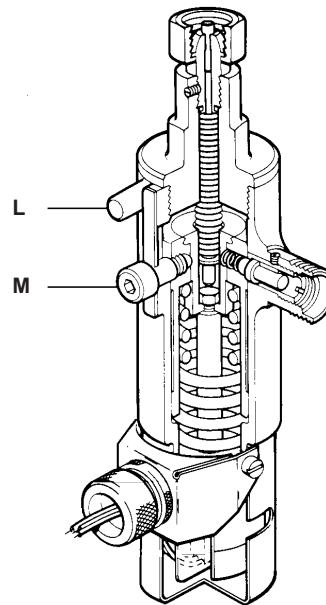

HL10
High limit cutout with micro switch

Optional extras

A micro switch (10) is available, which can be connected into an alarm system, and can be arranged to either make or break the electrical circuit on firing of the cutout.

It is suitable for the following ratings:

| | Voltage | Resistive load Amps | Inductive load Amps |
|----|----------|---------------------|---------------------|
| AC | 125 | 5 | 5 |
| | 250 | 5 | 5 |
| | up to 15 | 10 | 10 |
| DC | 30 | 5 | 3 |
| | 50 | 1 | 1 |
| | 75 | 0.75 | 0.25 |
| | 125 | 0.5 | 0.06 |
| | 250 | 0.25 | 0.03 |

Installation

Full details are given in the Installation & Maintenance Instructions, supplied with each unit.

Testing

As an emergency device, it is advisable to test this unit occasionally. This should be done either by temporarily raising the temperature of the equipment being controlled or by adjusting down the temperature at which the cutout is normally set to operate.

Warning

The cutout device is spring loaded and should not be opened up by unskilled persons, nor should it be 'fired' other than when attached to the valve.

Spare arts

Available spare parts are shown in heavy outline. Parts drawn in broken line are not supplied as spares.

Micro Switch Assembly

A, B (2 each)

Conversion Kit

A, B (2 each), C (2 each), D

