



Balanced Pressure Thermostatic Steam Traps RTA-125, RTH-125, RTV-125

Description

The balanced pressure steam trap contains a welded stainless steel element which is self-adjusting over the entire operating pressure range and approximately 23 °F (-5 °C) below saturated steam temperature.

Traps in this series are replacements for:

TA-125, TH-125, T-25, TB-25, TS-25, T-65, T-125; 1"H, N-100 angle; H, S-65, N-100 straightway and vertical, TV-125.

Model	RTA-125	RTH-125	RTV-125
	Angle	Straightway	Vertical
PMO	125 psi g	125 psi g	125 psi g
Sizes	1/2", 3/4" and 1"	1/2" and 3/4"	1/2" and 3/4"
Connections	NPT — male union inlet NPT — female outlet		
Construction	Brass body with stainless steel internals		
Option	Extended male inlet spud (1/2", 3/4" RTA-125 only) Near to steam fill 11 °F (-11.7 °C) All		

Typical applications

Vapor or vacuum two-pipe heating systems, radiators, convectors, fintube, hospital blanket warmers, sterilizers and stills, laundry and kitchen equipment, and small process equipment.

Limiting operating conditions

PMO	Maximum operating pressure	125 psi g (8.6 bar g)
	Maximum operating temperature	Saturated steam temperature
	Minimum operating pressure	25" Hg Vacuum

Pressure shell design conditions

PMA	Maximum allowable pressure	125 psi g/up to 353 °F (8.6 bar g/up to 178 °C)
TMA	Maximum allowable temperature	353 °F/0-125 psi g (178 °C/0-8.6 bar g)

1/2", 3/4", 1" RTA

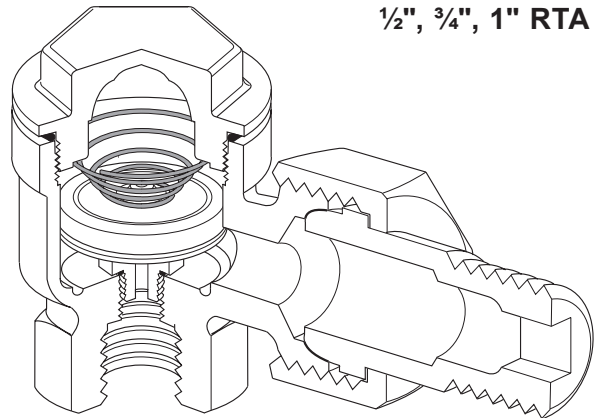

1/2", 3/4" RTH

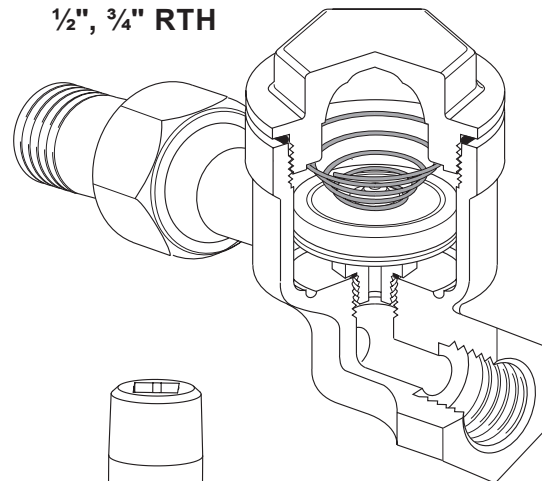

1/2", 3/4", RTV

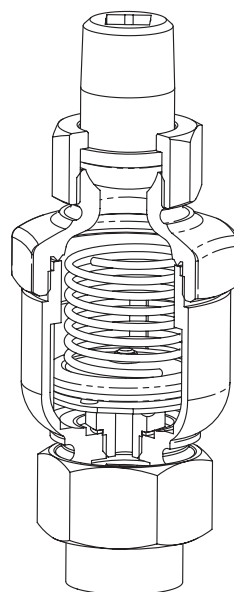

Materials

1/2", 3/4", 1" RTA

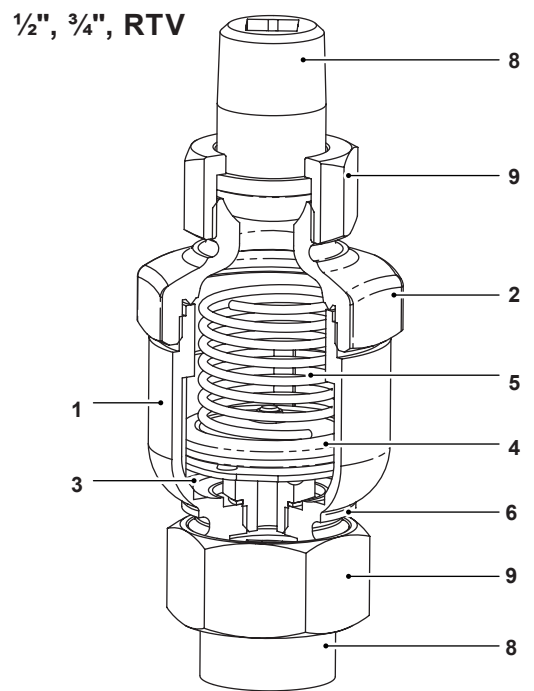
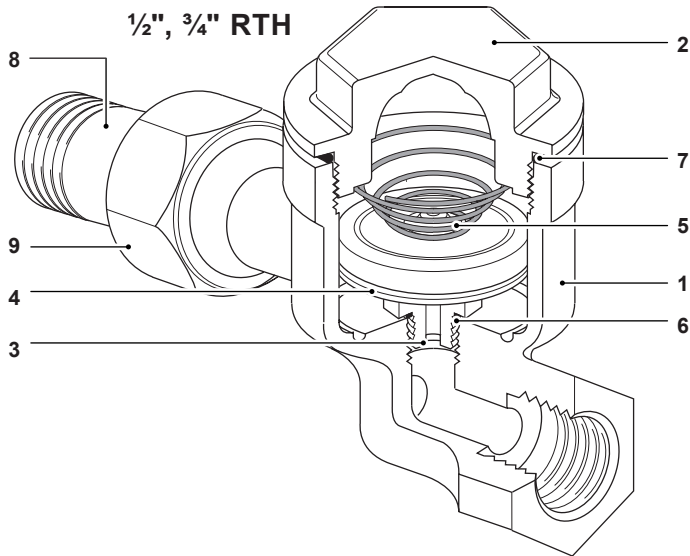
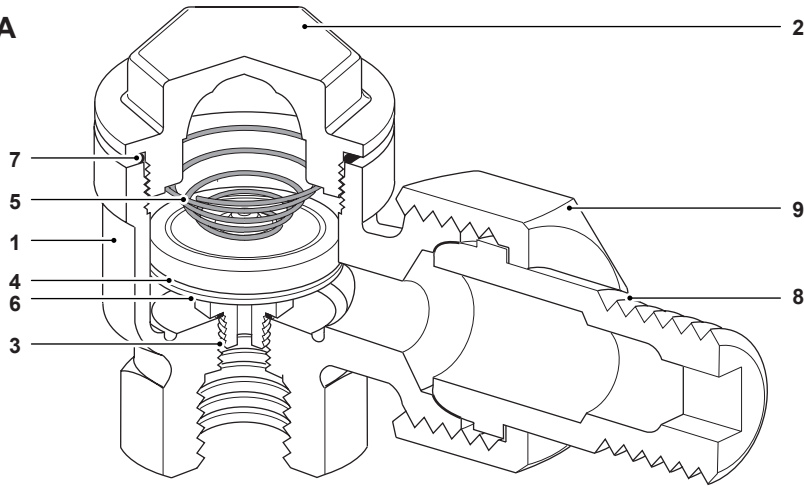

No.	Part	Material	
1	Body	Forged Red Brass	ASTM B124 Alloy C3770 TV-125 ASTM B62
2	Cap	Forged Red Brass	ASTM B124 Alloy C3770
3	Seat	Stainless Steel	
4	Thermostat	Stainless Steel BP99	
5	Spring	Stainless Steel	
6	Seat Gasket	Brass	
7	O-Ring	EPDM	
8	Union Nipple	Brass	ASTM B16
9	Union Nut	Brass	ASTM B16

Capacities

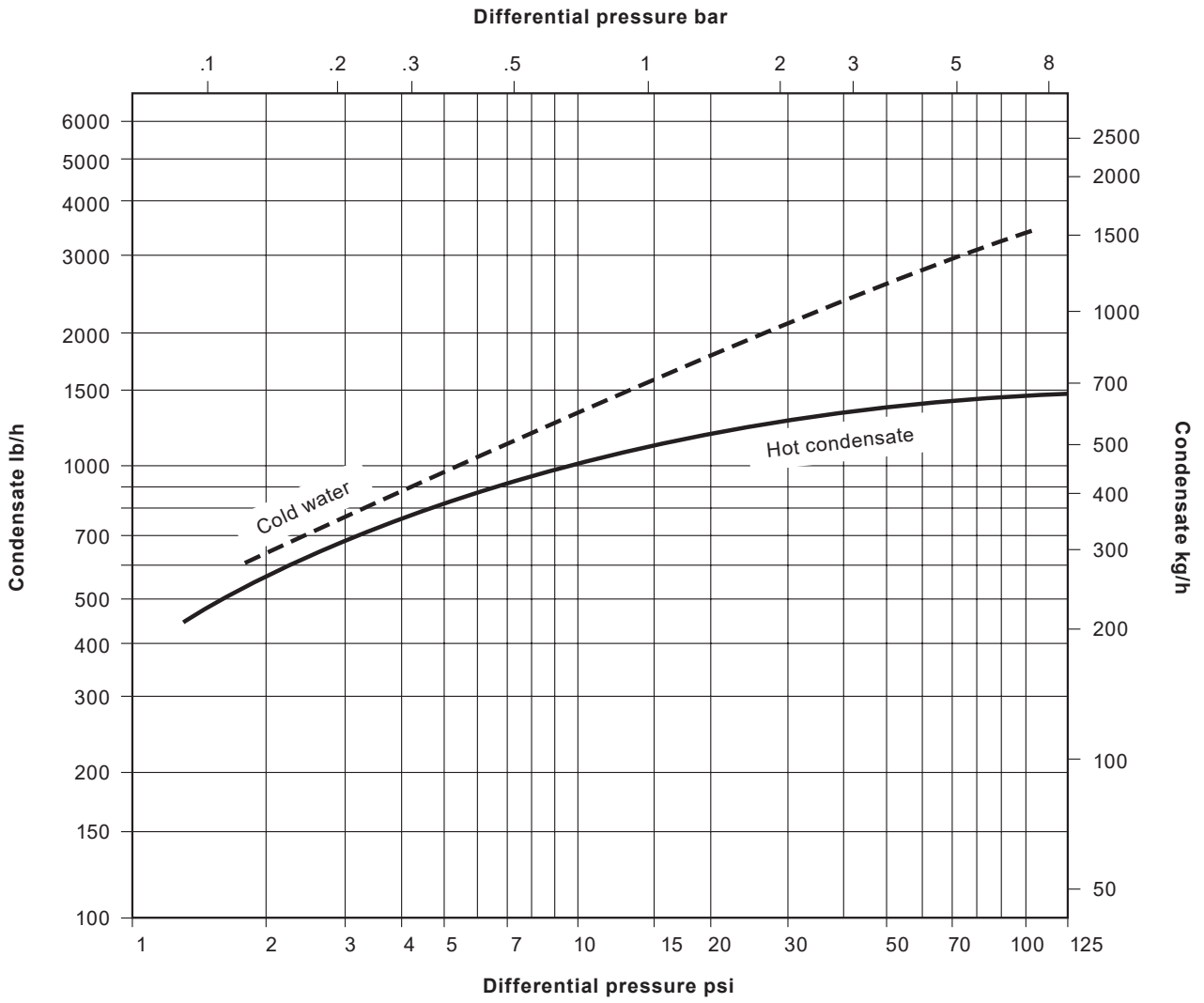

Orifice Size = .196"

- Water Capacity
- Hot Condensate

Dimensions/weights (approximate) in inches (mm) and lbs (kg)

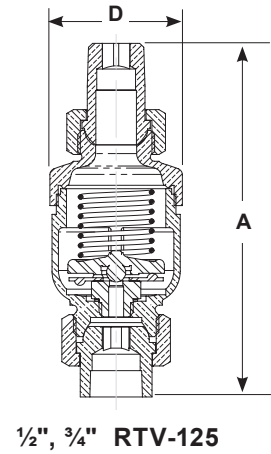
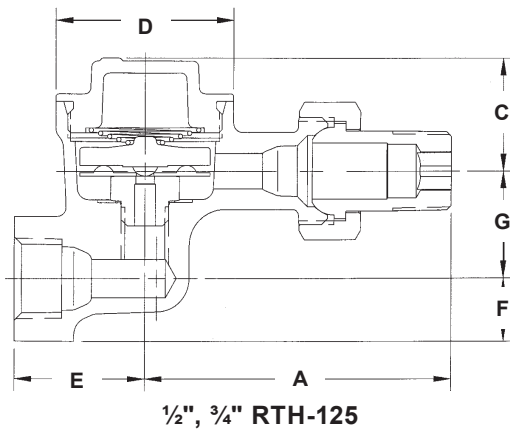
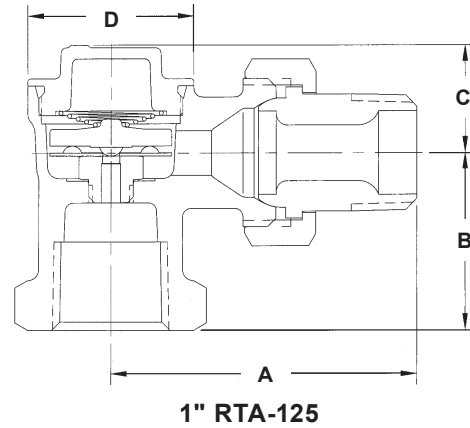
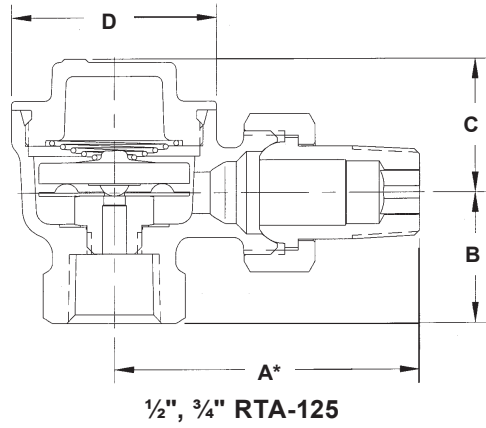

Size	Type	Body pattern	A	B	C	D	E	F	G	Weight
1/2"	RTA-125	Angle	2.8*	1.2	1.0	1.9	-	-	-	1 lb
			(71)	(30)	(25)	(48)	-	-	-	(0.5 kg)
	RTH-125	Straightway	3.2	-	1.2	1.9	1.4	0.7	1.1	1.4 lb
			(81)	-	(30)	(48)	(36)	(18)	(28)	(0.6 kg)
	RTV-125	Vertical	5.1	-	-	2.0	-	-	-	1.6 lb
			(130)	-	-	(51)	-	-	-	(7 kg)
3/4"	RTA-125	Angle	3.0*	1.2	1.0	1.9	-	-	-	1.3 lb
			(76)	(30)	(25)	(48)	-	-	-	(0.6 kg)
	RTH-125	Straightway	3.2	-	1.20	1.9	1.4	0.8	1.1	1.8 lb
			(83)	-	(30)	(48)	(36)	(20)	(28)	(0.8 kg)
	RTV-125	Vertical	5.6	-	-	2.0	-	-	-	2 lb
			(142)	-	-	(51)	-	-	-	(0.9 kg)
1"	RTA-125	Angle	3.5	2.0	1.2	1.9	-	-	-	2.8 lb
			(89)	(51)	(30)	(48)	-	-	-	(1.3 kg)

* with optional extended inlet spud, "A" dimension is 3.2".

Sample specification RTA, RTH

Steam traps shall be balanced pressure thermostatic type, self-adjusting to all pressures within their operating range. Bodies to be of forged red brass with male union inlet connection. Thermostatic element shall be of precision welded stainless steel construction, incorporating a hardened stainless steel valve head. Valve seats shall be stainless steel, and all internals, shall be replaceable without disturbing the piping connections.

Installation

A pipeline strainer should be installed ahead of any steam trap to protect the head and seat from dirt and scale. Full port isolating valves should be placed to permit servicing. Trap should be installed below the drainage point of the equipment with a collecting leg before the trap. For best operation, the element should be in a horizontal position as shown. For a freeze-resistant installation, inlet piping must be pitched toward the trap for gravity flow and the trap outlet must be free of any piping.

Maintenance

This product can be maintained without disturbing the piping connections. Complete isolation of the trap from both supply and return line is required before any servicing is performed.

The trap should be disassembled periodically for inspection and cleaning of the valve head and seat. Worn or damaged parts should be replaced using a complete Repair Kit.

Complete installation and maintenance instructions are given in IM-2-004-US, which accompanies the product.

Spare parts

Repair Kit (RTA, RTH)	B, C, D, E, F, G
Cap Assembly (RTA, RTH)	A, B
Repair Kit (RTV)	C, D, E, F, G

