

spirax sarco

PM Series Pneumatic Actuators for B Series Control Valves

Description

PM Series compact multi-spring diaphragm actuators are available in three sizes to suit the requirements of our ½" to 2" B Series control valves at various pressures. Actuators are available with an optional, top-mounted hand-wheel.

While many of these actuators will be operated directly by a 3-15 psig control signal, any of the Spirax Sarco range of positioners can be mounted with the optional spindle adaptor (part no. 3578000).

Available Types and Options

Standard version with corrosion resistant paint finish.
Full stainless steel version to special enquiry.
Spring-to-retract spindle.
Spring-to-extend spindle.

Technical Data

Ambient temperature range	-4F to 230°F
Maximum air pressure	60 psig
Stem travel	¾"
Air supply connection	¼" NPT

Materials

Diaphragm housing	Carbon Steel
Yoke	Ductile Iron
Diaphragm	Reinforced Nitrile
Gaskets	Neoprene
Springs	Steel (50CR4V2)
Bolts and nuts	Carbon/alloy steel

Available Spares

Diaphragm kit
Spring Kit
Spindle seal kit



Selection Guide

Type	PM	PM
Actuator size	2 = 36 sq.in 3 = 60 sq.in 7 = 109 sq.in	3
Spindle travel	2 = ¾"	2
Spring range	0 = 3-15 psig 1 = 3-9 psig 2 = 9-15 psig	0
Spring action	E = Spring extend R = Spring retract	E
Manual override	H = Handwheel	

Example:
1 x PM320E pneumatic actuator.

PM Series Pneumatic Actuators for B Series Control Valves

Maximum differential pressures for ANSI/FCI 70-2 Class IV and VI shut-off

Note: The actuator must be fully vented to achieve the differential pressures shown below. If the control system does not allow the actuator to be vented, please contact Spirax Sarco for assistance.

Spring Retract

Closes B Series 2-way valve and closes top seat of B Series 3-way valve on loss of air.

Model	Net Spring Range (psig)	Min. Air Pressure (psig)	1/2"		3/4"		1"		1-1/4"		1-1/2"		2"	
			Cv 6	Cv 3.5	Cv 8	Cv 6	Cv 13	Cv 8	Cv 20	Cv 13	Cv 28	Cv 20	Cv 50	Cv 28
PM220R	3 - 15	20	250	250	149	250	83	130	44	75	26	37	13	21
	6 - 18	23	250	250	250	250	205	250	114	197	76	107	45	71
PM221R	3 - 9	20	250	250	149	250	83	130	44	75	26	37	13	21
PM222R	9 - 15	20	250	250	250	250	250	250	184	250	126	177	77	121
PM320R	3 - 15	20					165	250	91	157	60	84	35	54
	6 - 18	23					250	250	209	250	144	202	88	138
PM321R	3 - 9	20					165	250	91	157	60	84	35	54
PM322R	9 - 15	20					250	250	250	250	228	250	141	222
PM720R	3 - 15	20							187	250	128	180	78	123
	6 - 18	23							250	250	250	250	175	250
PM721R	3 - 9	20							187	250	128	180	78	123

Spring Extend

Opens B Series 2-way valve and closes bottom seat of B Series 3-way valve on loss of air.

Model	Net Spring Range (psig)	Air Pressure (psig)	1/2"		3/4"		1"		1-1/4"		1-1/2"		2"	
			Cv 6	Cv 3.5	Cv 8	Cv 6	Cv 13	Cv 8	Cv 20	Cv 13	Cv 28	Cv 20	Cv 50	Cv 28
PM220E	3 - 15	18	250	250	149	250	83	130	44	75	26	37	13	21
		20	250	250	250	250	164	250	91	157	60	84	34	54
		25	250	250	250	250	250	250	208	250	143	201	87	137
		30							250	250	226	250	140	221
PM320E	3 - 15	18			250	250	165	250	91	157	60	84	35	54
		20			250	250	250	250	170	250	116	163	70	110
		25							250	250	250	250	159	250

Approximate dimensions and weights (inches and pounds)

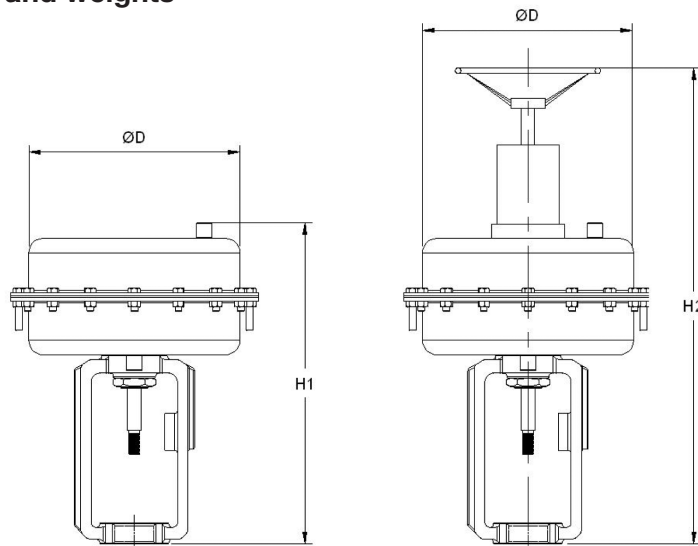

Actuator Model	Diameter D	H1	H2	Weight
PM200	9.25	9.31	16.67	20
PM300	11.22	11.6	22.66	42
PM700	15.43	14.7	27.52	49