



The Pivotrol® Pump Patented Digital Cycle Counter

Description

The monitoring of condensate return pump operation is an important activity for plant operations and maintenance personnel. The use of pressure powered pumps equipped with a digital cycle counter provides the ability to monitor pump operation, schedule preventative maintenance and estimate the amount of condensate recovered. The counter may operate in open and some closed loop condensate systems.

Specifications

Counter	8 Digit LCD display — NEMA 4 X, IP65
Options	BSP Threaded version (Standard counter only)

Limiting operating conditions

External operating temperature range	Counter	14 °F to 122 °F (-10 °C to 50 °C)
Maximum sensor pressure	PMO	300 psi g (21 bar g)
Maximum operating temperature	TMO	500 °F (260 °C)

Pump capacities

Model	Approximate Gallons/Cycle
PTC	7.1 / 26.9L
PTF	8.4 / 31.8L
PTF-HP	16 / 60.6L
PTF4	26.9 / 102L

Materials

No.	Part	Material
1	Enclosure	Aluminum
2	Gaskets	
3	Housing	Stainless steel
4	Sealing nut	Stainless steel and Teflon®
5	Insulator	
6	Probe	Stainless steel
7	Plug receptacle	Stainless steel
8	Plug	Stainless steel

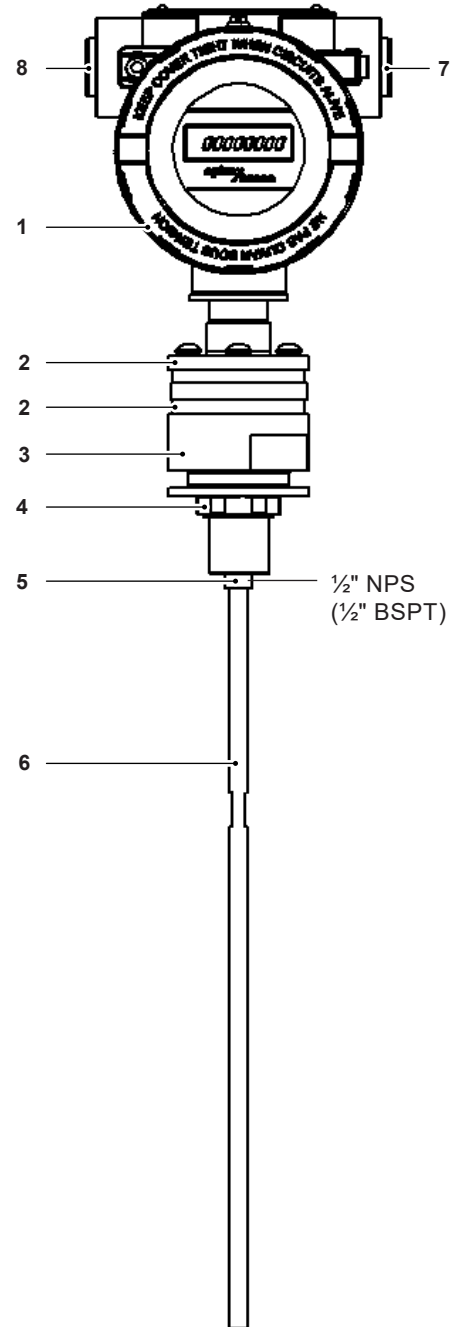

Standard unit

Dimensions/weights (approximate) in inches (mm) and lbs (kg)

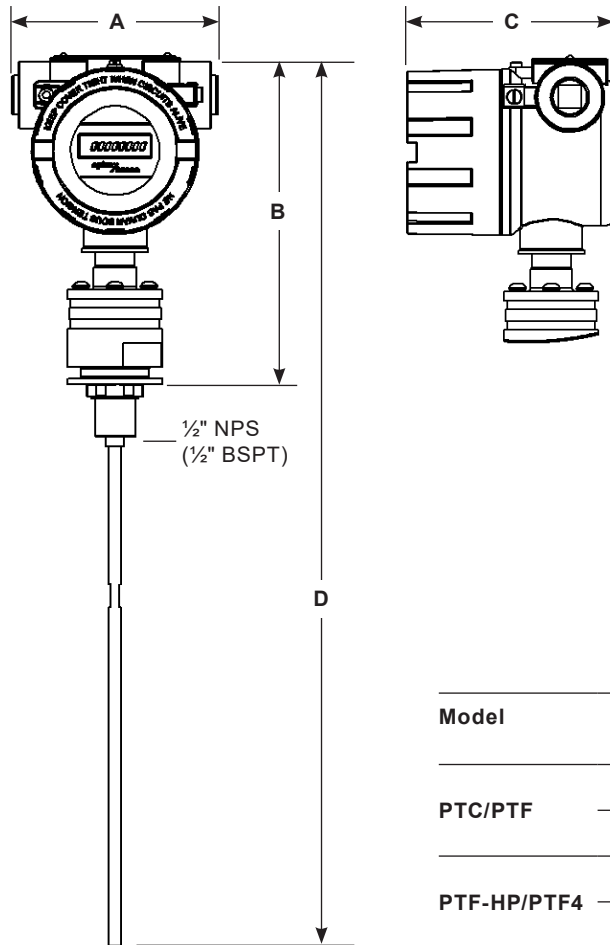

Model	A	A w/Aux	B	C	D	Weight
PTC/PTF	4.4	4.9	7.0	4.4	17.0	5 lb
	(112)	(124)	(178)	(112)	(432)	(2.3 kg)
PTF-HP/PTF4	4.4	4.9	7.0	4.4	25.4	5.1 lb
	(112)	(124)	(178)	(112)	(645)	(2.3 kg)

Enclosure approvals

For FM approved enclosure: CL I.
 GR. A,B,C,D;
 CL. II. GR. E,F,G;
 CL. III.;
 TYPE 4X
 For CSA Class I Group A, conduit seal is required within 18 inches.

For FM approved enclosure: CL. I, ZONE 1, AEx d IIC, IP66

For IECEx: IECEx FMG 06.0003U, Ex d II C, IP68

For Ex: II 2 GD Ex d II C; IP68; FTZU 04 ATEX 0265 U AMBIENT TEMP.: - 40 °C to + 85 °C (- 40 °F to 185 °F)

Battery is suitable for up to 10 years of uninterrupted operation.

Safety and regulatory compliance

Seating nut contains Teflon®.

This product is not intended to be submerged.

Installation (see IM-P207-09-US)

1. Place counter in ½" NPS (½" BSPT) hole in pump cover (only hole available)
2. Orientate counter in desired direction.
3. Screw sealing nut until wrench tight.

Caution: Before installation or any maintenance is performed, ensure that all steam, condensate, air or gas lines are closed and internal pressure is relieved to prevent injury.

Plugs (7) and (8) should not be unscrewed and will void warranty.

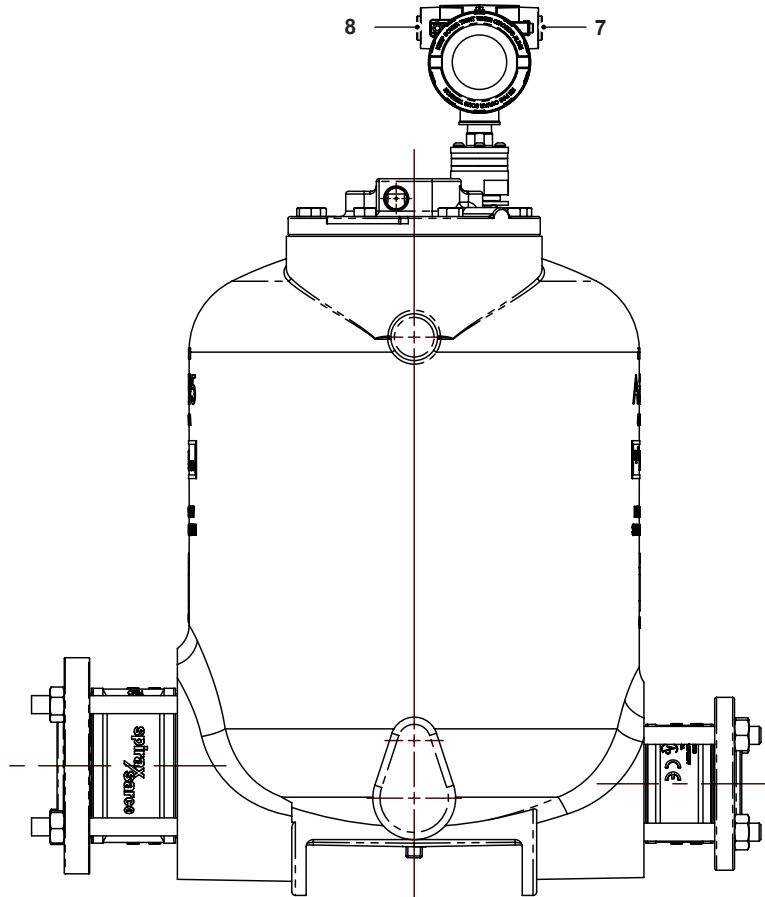

Orientation (see IM-P207-09-US)

The Digital Cycle Counter orientation may be changed from its original position in the Pivotrol cover and mechanism assembly.

Caution: Before any maintenance is performed, ensure that all steam, condensate, air or gas has be closed and internal pressure is relieved to prevent injury.

1. Unscrew sealing nut.
2. Twist cycle counter into desired position, ensuring cable remains in place.
3. Tighten sealing nut.