

Gilflo ILVA Flowmeters System Overview

Description

The Gilflo ILVA metering system consists of 2 major parts:

1. The Gilflo ILVA pipeline unit. This is installed in the line where the flow is to be measured. Using impulse pipework, this is connected to:
 - a- To act as a suitable input to an EMS/DCS which can be programmed by the user to carry out the linearizing of the output signal based on the calibration data that is supplied with each Gilflo ILVA meter. Additional inputs from the pressure and temperature transmitters can be used to carry out density compensation for compressible flow applications.
 - b- To supply an M750 Display Unit. This gives a non-compensated display of rate of flow and totaled flow. It is suitable for liquid, gas and steam applications where density compensation is not required.
 - c- To supply an M800 (steam) or (gas) Flow Computer. Use of the pressure and temperature transmitters enables automatic density compensation to be carried out for compressible flow applications. See relevant TIS's for details of pressure/temperature limits for M800 Flow Computers.
2. The M610 DP transmitter assembly. This measures the differential pressure across the Gilflo ILVA pipeline unit and converts it to a 4-20mA output signal. This output signal can be used in a number of ways:
 - a- To act as a suitable input to an EMS/DCS which can be programmed by the user to carry out the linearizing of the output signal based on the calibration data that is supplied with each Gilflo ILVA meter. Additional inputs from the pressure and temperature transmitters can be used to carry out density compensation for compressible flow applications.
 - b- To supply an M750 Display Unit. This gives a non-compensated display of rate of flow and totaled flow. It is suitable for liquid, gas and steam applications where density compensation is not required.
 - c- To supply an M800 (steam) or (gas) Flow Computer. Use of the pressure and temperature transmitters enables automatic density compensation to be carried out for compressible flow applications. See relevant TIS's for details of pressure/temperature limits for M800 Flow Computers.

The Gilflo ILVA pipeline unit can be used to measure the flow of most industrial liquids, gases and vapors within the pressure and temperature limits detailed in the TIS's.

Installation

Care must be taken to meet all the requirements of the Installation and Maintenance Instructions that are included with the equipment.

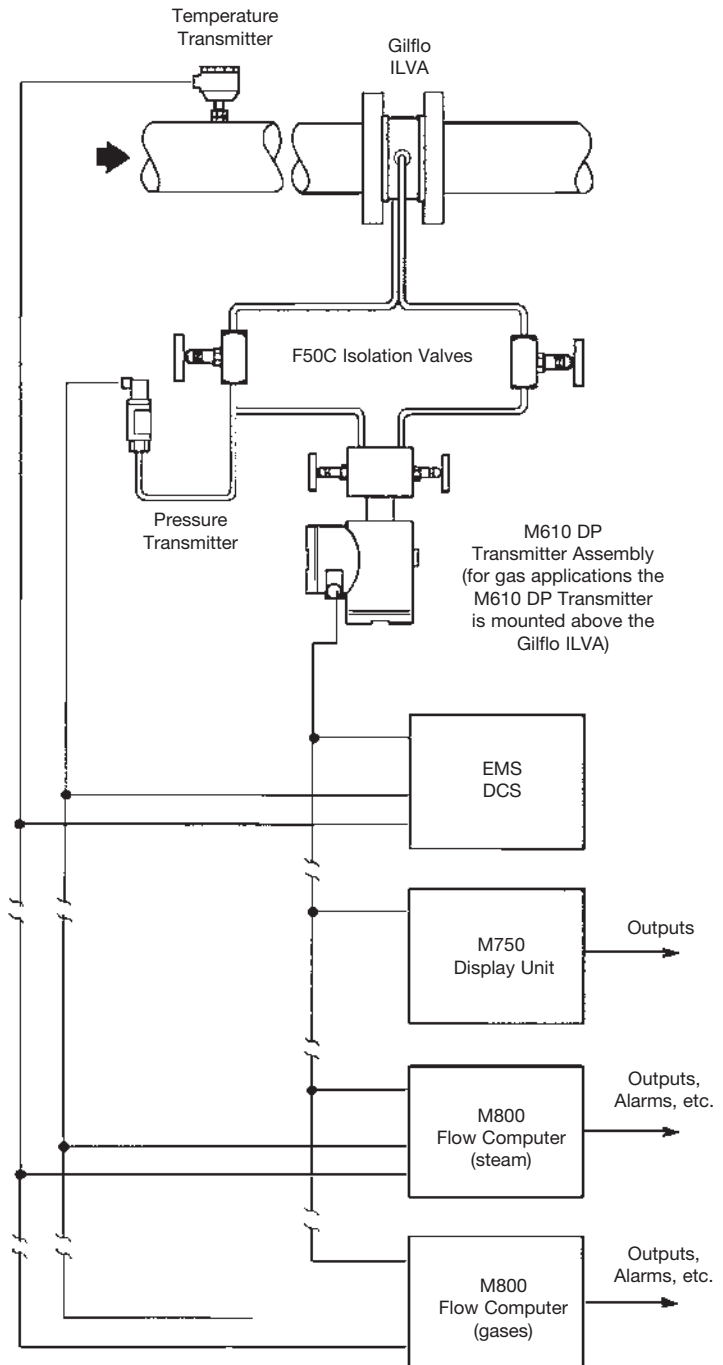

Gilflo ILVA Flowmeters - System Overview

Installation points to watch:

1. Ensure that all pipework is adequately supported and properly aligned. Specialcare should be taken to ensure that the Gilflo ILVA pipeline unit is concentrically mounted in the line. (Special installation kits are available to order for sizes 2" to 8").
2. The Gilflo ILVA pipeline unit should be selected on capacity rather than line size. Where line size changes on steam systems are necessary, use eccentric reducers to avoid buildup of condensate.
3. The minimum recommended lengths of straight pipe upstream and downstream are 6D and 3D respectively. See TIS (ref TIS 8.009) for Gilflo ILVA for more details.
4. Take care to ensure the correct direction of flow as indicated by the arrow on the meter body.
5. Take care to avoid reverse flow through the meter.
6. Avoid installing the meter downstream of a pressure reducing valve (especially on steam systems) as this may cause inaccurate readings. Similarly, avoid installing the meter downstream of a partially open valve.
7. Remember that actuated valves may cause rapid pressure fluctuations which could cause damage.
8. On steam or liquid systems, the M610 DP transmitter assembly is mounted below the meter. Take care to ensure that all impulse lines remain full to prevent damage to the DP transmitter through contact with steam or high temperature liquid.
9. For steam applications, care should be taken to ensure adequate line drainage, trapping etc. so as to avoid condensate slugs impacting the meter. Where practical, steam separators should be fitted. These should be drained using a float trap set.
10. For gas applications, the M610 DP transmitter assembly is installed above the pipework. Ensure that the impulse lines allow free drainage of moisture away from the DP transmitter and back into the pipeline.

Electrical wiring

All electrical wiring must be carried out to the appropriate standards.
Full wiring interconnection details are included with the equipment.

Associated equipment

Item	Description	Technical literature
M610	DP transmitter assembly	TI-P335-10 US
Gilflo ILVA	Pipeline unit	TIS 8.009
M750	Display unit	TI-P332-08 US
F50C	Isolation valve	TIS 8.401
M800	Steam flow computer	TI-P331-04-US
M800	Gas flow computer	TI-P333-24-US