

spirax/sarco

Gilflo ILVA Flowmeter 10" and 12"

Description

The Gilflo ILVA flowmeter operates on the spring loaded variable area principle and produces a differential pressure related to the rate of flow. It can be used with most industrial fluids, gases and both saturated and superheated steam. A general description of the ILVA flowmetering system and its associated equipment is given in a separate TI sheet.

Sizes and pipe connections

10" and 12"

Suitable for fitting between the following flanges:

EN 1092 PN16, PN25 and PN40.

ASME (ANSI) B 16.5 Class 150, 300 and 600.

JIS 20.

KS 20.

The Gilflo ILVA flowmeter should be installed in pipework manufactured to BS 1600 or ASME (ANSI) B 36.10 Schedule 40. For different pipe standards/schedules, downstream spool pieces with an equivalent internal diameter to BS 1600 or ASME (ANSI) B 36.10 Schedule 40 should be used. If this is not possible, please contact Spirax Sarco Limited.

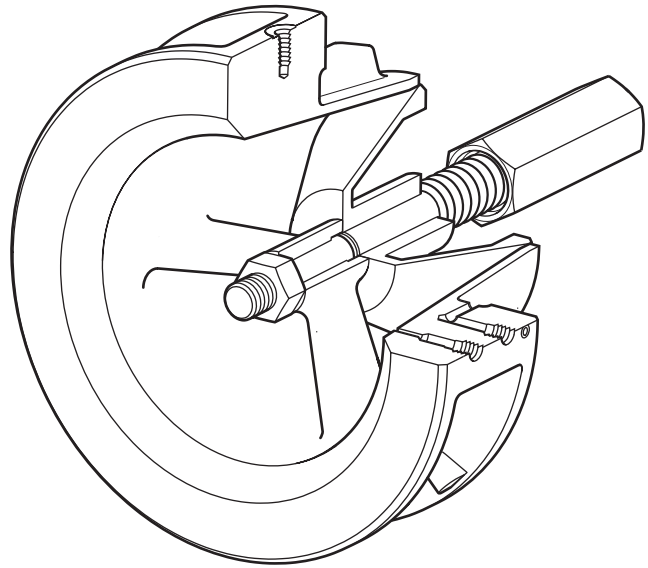

Materials

Part	Material
Body	Cast stainless steel S.316 (CF8M/1.4408)
Internals	431 S29/S303/S304/S316
Spring	Inconel X750

Pressure/temperature limits

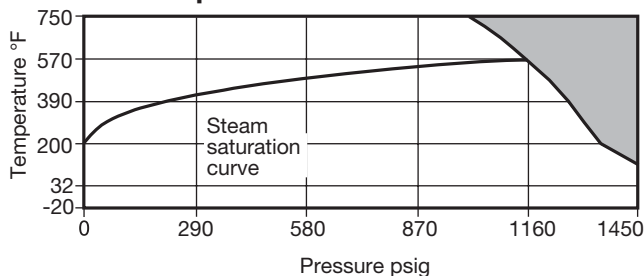

The product **must not** be used in this region.

Body design conditions	ASME (ANSI) 600
PMA Maximum allowable pressure	1450 psig @ 120°F
TMA Maximum allowable temperature	750°F @ 1000 psig
Minimum allowable temperature	-20°F
PMO Maximum operating pressure is dependant on the flange specification	
Minimum operating pressure	9 psig
TMO Maximum operating temperature	750°F @ 1000 psig
Minimum operating temperature	-20°F
Note: For lower operating temperatures consult Spirax Sarco	
Maximum viscosity	30 centipoise
DPMX Maximum differential pressure	200 in
Designed for a maximum cold hydraulic test pressure of 2248 psig	

Performance

The Gilflo ILVA is used in conjunction with linearising electronics such as the M800 flow computer or M750 display unit. Alternatively the output signal linearisation can be performed on an EMS/BEMS or equivalent.

Accuracy when used with M800 or M750:

±1% of measured value from 5% to 100% of maximum rated flow.

±0.1% FSD from 1% to 5% of maximum rated flow.

Repeatability better than 0.25%

Turndown: up to 100:1

Caution: The steam mass flow transmitters are uniquely configured at the factory to work with a single, specific Gilflo ILVA flowmeter. For correct operation the configured transmitter must always be installed with its allocated flowmeter. Labels on the packaging give the serial numbers of the matched products.

Pressure drop

The maximum pressure drop across the Gilflo ILVA pipeline unit is 498 m bar (200 ins water gauge) at maximum rated flow.

Flow capacity

To determine the capacity of the Gilflo ILVA for different fluids, it is necessary to calculate the equivalent water flowrate Q_E (in l/min) as described in Step 1, under the section 'sizing the Gilflo ILVA' then selecting the appropriate size of flowmeter from the Table under Step 2 overleaf.

How to order

Spirax Sarco 10" Gilflo ILVA flowmeter for installation between ANSI Class 300 flanges. The body material is to be 316 stainless steel. The flow medium will be saturated steam at 145 psig and the maximum flow will be 61,730 lbs/hr. For a general description of the Gilflo ILVA metering system, see TI-8-010-US which also gives details of associated equipment.

Gilflo ILVA Flowmeter

10" and 12"

Dimensions/weights (approximate) in inches and pounds

Size	A	B	C	D	E	F	Weight
10"	4.1	8	17.5	13	1.4	1.4	91.5
12"	4.7	9.8	20.9	15.2	1.7	1.4	147.7

Note:- Pressure tappings are threaded ¼" NPT

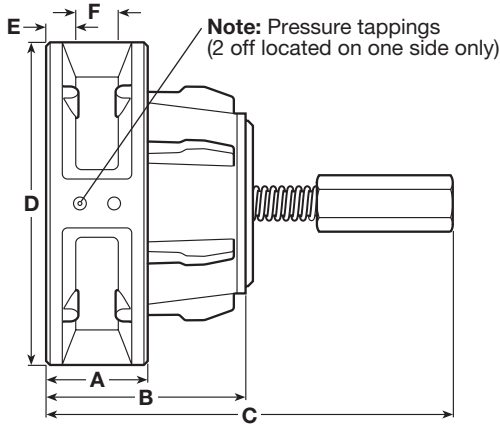

Safety information, installation and maintenance

For full details see the Installation and Maintenance Instructions supplied with the product.

Installation note:

The following main points are given here for guidance:

- The Gilflo ILVA should be mounted with a minimum of 6 straight pipe diameters upstream and 3 downstream. No valves, fittings or cross sectional changes are permitted within these pipe lengths. Where an increase in nominal pipe diameter is required upstream of the flowmeter, the length of straight pipe should be increased to 12 diameters. Similarly, where a Gilflo ILVA is installed downstream of two 90 degree bends in two planes, a pressure reducing valve or a partially open valve, 12 upstream pipe diameters should be allowed.
- It is important that the internal upstream and downstream diameters of pipe are smooth. Ideally seamless pipes should be used. It is recommended that slip-on flanges be used to avoid any intrusive weld beads on the internal diameter of the pipe.
- Care should be taken to install the Gilflo ILVA concentrically in the line. If this is not done, flow measurement errors may occur.
- The Gilflo ILVA should be mounted horizontally. For vertical installations, consult Spirax Sarco.
- For steam applications, good basic steam engineering practices should be followed:
 - Correct line drainage through adequate trapping.
 - Good alignment and support of associated pipework.
 - Line size changes achieved by the use of eccentric reducers.

Maintenance note:

There are no user serviceable parts in the Gilflo ILVA. A visual check together with confirmation that the orifice/cone reference dimension is within tolerance is possible.

Sizing the Gilflo ILVA for saturated steam - lb/h

Maximum flowrates in lb/h at different pressures (psig)

Note: Maximum steam flowrates are calculated at a differential pressure across the Gilflo ILVA pipeline unit of 200 ins H₂O.

Size	Steam pressure psig	15	44	73	102	145	174	218	290	363	435	580
10"	Maximum flow	33786	47675	57708	66128	76959	83379	92162	105216	116909	127654	147172
	Minimum flow	344	476	578	661	769	833	919	1052	1168	1276	1473
12"	Maximum flow	48782	67514	81723	93646	108983	118075	130514	148999	165558	114638	208414
	Minimum flow	487	675	820	939	1091	1179	1303	1490	1658	1808	2083

Sizing the Gilflo ILVA Meter

In order to determine the flow capacity of a Gilflo ILVA pipeline unit, it is necessary to calculate the Equivalent Water Flowrate (Q_e) based on the anticipated actual flow.

Figure 2 is then used to select the appropriate unit.

- Determine Equivalent Water Flowrate (Q_e) in U.S. gpm:

Liquids:

$$Q_e = \frac{m}{500} \sqrt{\frac{D_e}{D_i}} \quad \text{or} \quad Q_e = Q_1 \sqrt{\frac{D_i}{D_e}}$$

- Q_e = equivalent flow rate of water at 70°F (U.S. gpm)
- m = maximum flow rate of service liquid (lb/hr)
- D_e = density of water at calibration (62.305 lb/ft³)
- D_i = density of service liquid (lb/ft³)
- Q_1 = maximum flow rate of service liquid (US gpm)

Gases:

$$Q_e = \sqrt{D} \times \frac{(0.0158) \times m}{P_s} \times \frac{T_s}{T_f}$$

$$\text{or } Q_e = (0.948) \times Q_g \sqrt{D} \times \frac{P_s}{P_f} \times \frac{T_f}{T_s}$$

- Q_e = water equivalent flow rate at 70°F (U.S. gpm)
- m = maximum flow rate of gas (lb/hr)
- D = gas density at 14.7 psia, 520°R (60°F) (lb/ft³)
- P_f = flowing pressure of gas (psia)
- P_s = standard atmospheric pressure (14.7 psia)
- T_s = standard absolute temperature (520°R)
- T_f = flowing temperature of gas (°R=°F + 460)
- Q_g = maximum flow rate of gas (SCFM)

Steam:

$$Q_e = (0.0158) \times m \sqrt{v}$$

- Q_e = water equivalent flow rate at 70°F (U.S. gpm)
- m = maximum flow rate of steam (lb/hr)
- v = specific volume of steam at normal pressure and temperature (ft³/lb)

- Select from the table below the Gilflo ILVA meter with a maximum Q_e that closely matches (but exceeds) the application Q_e determined in step 1.

Flowmeter type	Max. Q_e U.S. gpm	Maximum pressure drop Ins Wg
10"	2047	200
12"	2900	200