



Condensate Return and Boiler Feed Pumps "G" Series

Description

Spirax Sarco "G" Series condensate and boiler feed pumps are packaged units completely assembled, wired and tested at the factory. They are used in low pressure steam heating systems to collect and quickly return condensate to the boiler or boiler feed unit. Pumping action is controlled by an integral float switch on simplex (one pump) units or mechanical alternator on duplex (two pump) units. Unlike boiler feed units which are controlled by a boiler mounted control and equipped with a makeup valve mechanism, condensate pumps usually do not directly supply boiler makeup water.

Available Types

Simplex units

Simplex units are equipped with vapor tight, heavy duty float switch control with stainless steel float. Easily field adjustable to provide proper pump control and operation.

Duplex units

Duplex units offer some additional distinct advantages over simplex units. They are used where an unusually heavy amount of condensate must be returned or where it is desirable to have a stand-by pump available. Equipped with a float operated, automatic mechanical alternator, they provide several benefits.

- **System overload protection**
The second pump is activated if the rate of condensate return exceeds the limits of the first pump.
- **Extra long service life**
Each of the two pumps is activated automatically on alternating pumping cycles so the work load is evenly distributed between the two pumps.
- **Back-up system protection**
A second pump is automatically actuated if the first one fails to start. Maintenance or repairs can be made on either pump without shutting down the other one or interrupting system operation.

Limiting conditions

Capacity: to 18 gpm (68 Liters per minutes). Discharge pressures: 20, 30 and 40 psi (1.4, 2.1 and 2.8 bar).

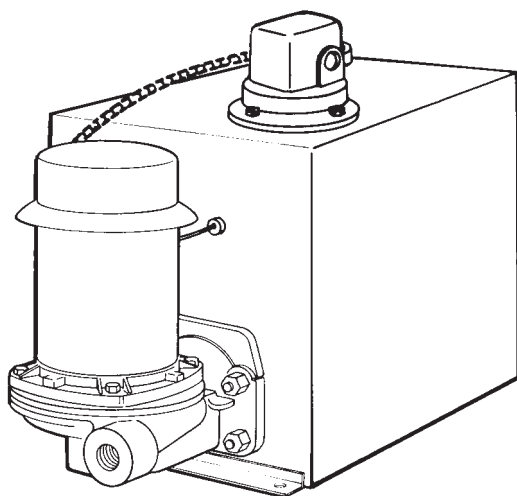

Simplex Unit

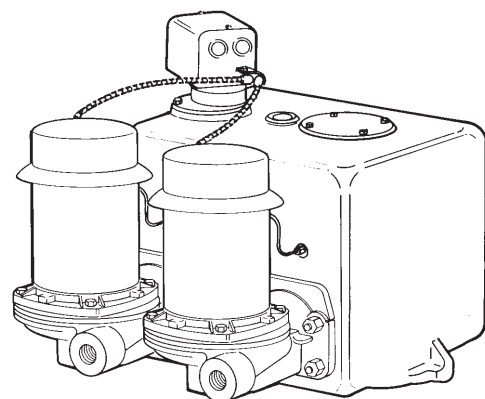

Duplex Unit

Receiver

Close grained cast iron.

Simplex unit 6,15, 21 and 45 gallon sizes (23, 57, 79 and 170 Liter sizes).

Duplex unit 15, 21 and 45 gallon sizes (57, 79 and 170 Liter sizes).

Welded, copper bearing steel.

Simplex unit 10, 20 and 45 gallon sizes (38, 76 and 170 Liter sizes).

Duplex unit 20 and 45 gallon sizes (76 and 170 Liter sizes).

Heavy duty, drip proof motors

Heavy duty, drip proof motors are designed for continuous operation. Ball bearings are prelubricated and shielded. Motors have stainless steel shaft -operated at 3450 rpm 60Hz. Both single phase 115/230 volt with built-in overload protection, and three phase 230/460 volt (or 208 volt) motors are available with O.D.P. or special TEFC enclosures.

All parts of the pump and motor which are subject to normal wear are easily accessible by removal of motor and canopy, attached with universal type 4 bolt flange mounting. Service of impeller and seal is also made easy. Entire motor can be removed without disturbing plumbing or electrical connections.

Pump and motor assembly

Pump and motor assembly is close coupled centrifugal design with enclosed type bronze impeller and wearing ring. The bronze impeller is designed to assure smooth, efficient water passage. No close clearances that are subject to rapid wear and reduced efficiency.

Mechanical shaft seal designed for temperatures to 250 °F (121 °C). Seal is vented to receiver to insure adequate lubrication at all times.

Optional extras

Suction Isolation Valve

When installed between the pump and receiver on simplex units, it allows the pump motor assembly to be removed without draining the receiver. On duplex units, it permits one pump to be removed while the other one continues to operate without interrupting system operation.

Ordering codes and models

Motor		Pump		Cast Iron Receiver Sizes							
Phase and Voltage	HP	Discharge Pressure psi	gpm	6 Gallon 8000 EDR	15 Gallon 12000 EDR		21 Gallon 12000 EDR		45 Gallon 12000 EDR		
				Simplex	Simplex	Duplex	Simplex	Duplex	Simplex	Duplex	
Single 115/ 230 V.	1/3	20	18	GC2S61	GC2S151	GC2D151	GC2S211	GC2D211	GC2S451	GC2D451	
	½	30	18	GC3S61	GC3S151	GC3D151	GC3S211	GC3D211	GC3S451	GC3D451	
	¾	40	18	GC4S61	GC4S151	GC4D151	GC4S211	GC4D211	GC4S451	GC4D451	
Three 230/ 460 V.	1/3	20	18	GC2S63	GC2S153	GC2D153	GC2S213	GC2D213	GC2S453	GC2D453	
	½	30	18	GC3S63	GC3S153	GC3D153	GC3S213	GC3D213	GC3S453	GC3D453	
	¾	40	18	GC4S63	GC4S153	GC4D153	GC4S213	GC4D213	GC4S453	GC4D453	

Motor		Pump		Welded Steel Receiver Sizes				
Phase and Voltage	HP	Discharge Pressure psi	gpm	10 Gallon 8000 EDR	20 Gallon 12000 EDR		45 Gallon 12000 EDR	
				Simplex	Simplex	Duplex	Simplex	Duplex
Single 115/ 230 V.	1/3	20	18	GS2S101	GS2S201	GS2D201	GS2S451	GS2D451
	½	30	18	GS3S101	GS3S201	GS3D201	GS3S451	GS3D451
	¾	40	18	GS4S101	GS4S201	GS4D201	GS4S451	GS4D451
Three 230/ 460 V.	1/3	20	18	GS2S103	GS2S203	GS2D203	GS2S453	GS2D453
	½	30	18	GS3S103	GS3S203	GS3D203	GS3S453	GS3D453
	¾	40	18	GS4S103	GS4S203	GS4D203	GS4S453	GS4D453

Dimensions (approximate) in inches (mm) and lbs (kg)

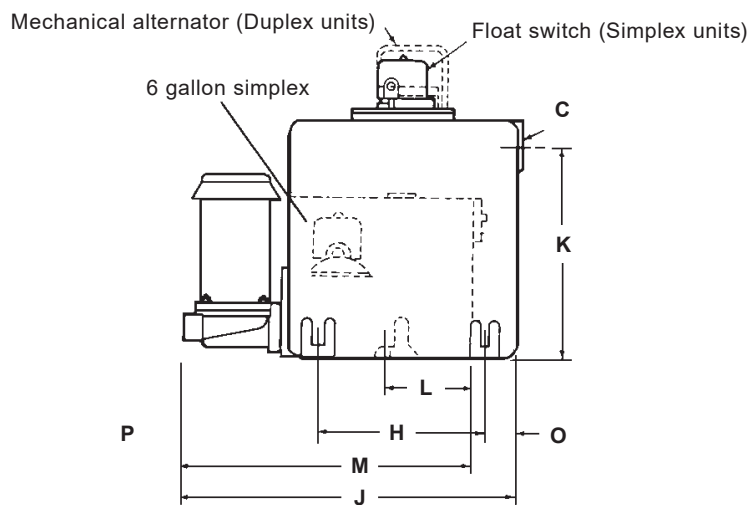
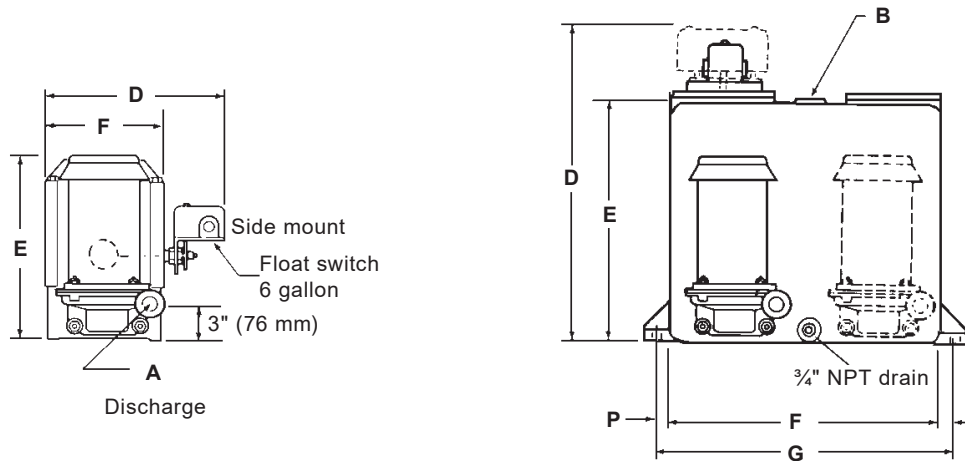

Cast Iron receivers

Receiver size	A	B	C	D	E	F	G	H	J	K	L	M	O	P	Weight	
Simplex 6 gallon	1 (25)	1 (25)	2 (51)	14.5 (368)	14.5 (368)	9.5 (241)				9.0 (229)		27 (686)			115 (52)	
Simplex 15 gallon				21 (533)	15.6 (396)	17.6 (447)	19.8 (503)		26.5 (673)	13.3 (338)	9.3 (236)				1 (25)	215 (98)
Duplex 15 gallon				21.5 (546)												
Simplex 21 gallon		1 1/4 (32)	1 1/4 (32)	2 (51)	17 (432)	12.4 (315)	22.7 (577)	27.7 (704)	18 (457)	31.8 (808)	10.2 (259)			1.5 (38)	1.5 (38)	260 (118)
Duplex 21 gallon		18 (457)														
Simplex 45 gallon		1 1/2 (38)	1 1/2 (38)	2 1/2 (64)	21.8 (554)	17.3 (439)	26.7 (678)	28.7 (729)	20 (508)	36.7 (932)	15 (381)			2.85 (72)	1 (25)	410 (186)
Duplex 45 gallon		22.8 (579)														

Dimensions (approximate) in inches (mm) and lbs (kg)

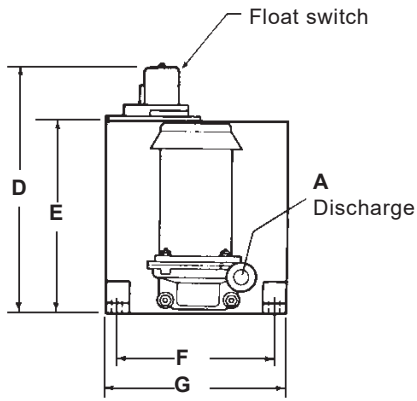

End view steel 10 gallon Simplex unit

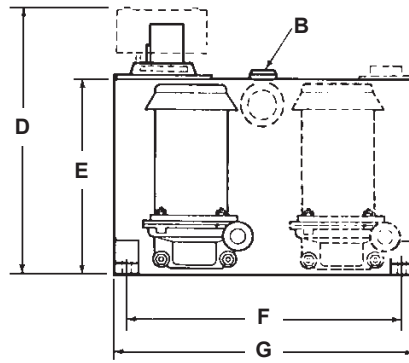

End view steel 20 gallon Simplex and duplex unit

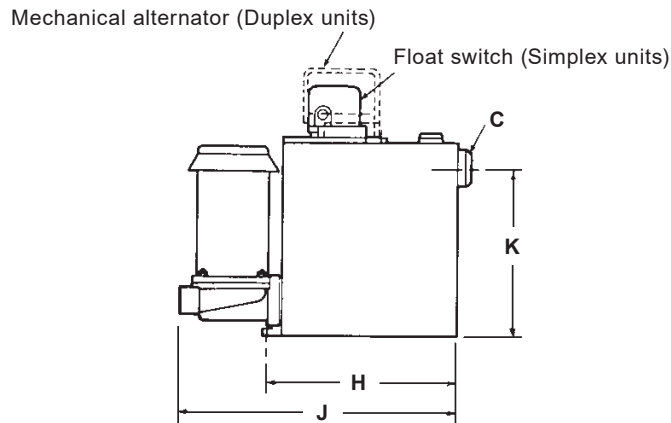

Side view steel 10 and 20 gallon Simplex and duplex unit

Receiver size	A	B	C	D	E	F	G	H	J	K	Weight
Simplex 10 gallon	1 (25)	1 (25)	2 (51)	18.2 (462)	14.2 (361)	12.5 (318)	14.3 (363)	15.2 (386)	25.2 (640)	12.7 (323)	108 (49)
Simplex 20 gallon						22.5 (572)	24.3 (617)				138 (63)
Duplex 20 gallon				19.7 (500)	24.4 (620)	190 (86)					
Simplex 45 gallon		1.5 (38)	3 (76)	22.4 (569)	18.4 (467)	24.4 (620)	26.4 (671)	24.4 (620)	35.4 (899)	15.7 (399)	238 (108)
Duplex 45 gallon											24.4 (620)