

spirax sarco

FTC62 Carbon Steel Ball Float Steam Traps

Description

The FTC62 is a carbon steel bodied ball float steam trap having stainless steel working internals and automatic air venting facility.

L-R Select **L-R** for a flow direction of **Left-to-Right**

or

R-L Select **R-L** for a flow direction of **Right-to-Left** (shown below)

FTC62 available options when facing the body:

Optional extra:

On request the cover (2) can be drilled and tapped for the purpose of fitting a balance line.

If this option is requested at the time of order placement there will be an extra charge incurred and the unit will be treated as a special product.

Standards

This product fully complies with the requirements of the European Pressure Equipment Directive 2014/68/EU and carries the **CE** mark.

Certification

This unit is available with certification to EN 10204 3.1.

Note: All certification / inspection requirements must be stated at the time of order placement.

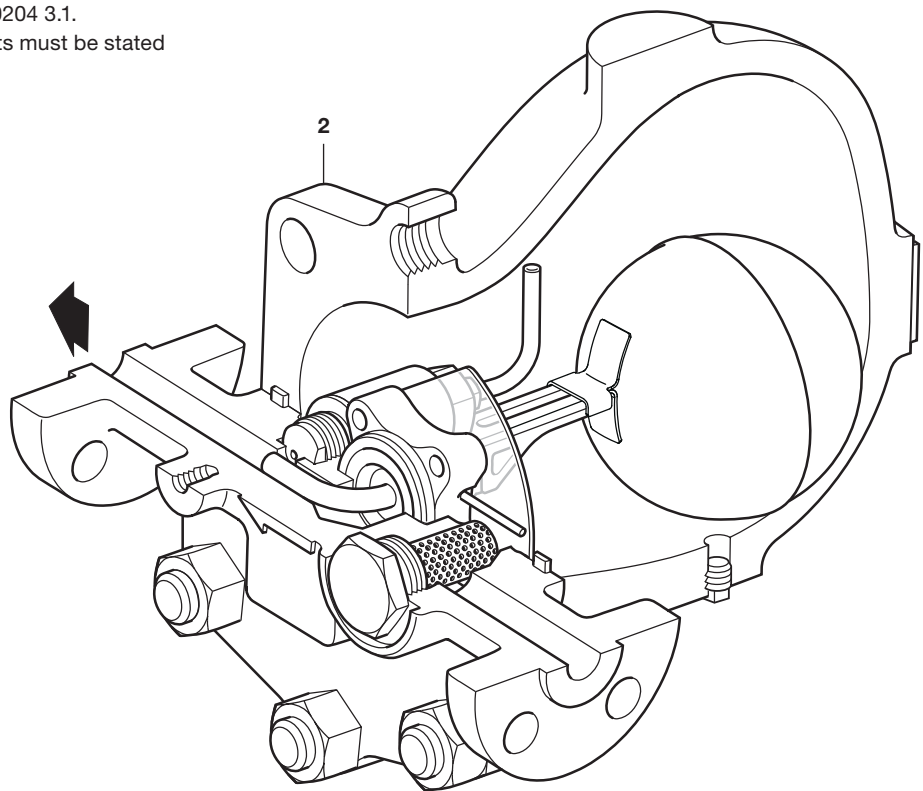

Sizes and pipe connections

1/2", 3/4" and 1" Screwed NPT (BSP optional)

1/2", 3/4" and 1" Socket weld ends to BS 3799 and Class 3000 lbs

Standard flanges:

1/2", 3/4" and 1" Flanged ASME B 16.5 Class 600

DN15, DN20 and DN25 Flanged EN 1092-1 PN100 optional

*Local regulation may restrict the use of this product below the conditions quoted. Limiting conditions refer to standard connections only.
In the interests of development and improvement of the product, we reserve the right to change the specification.*

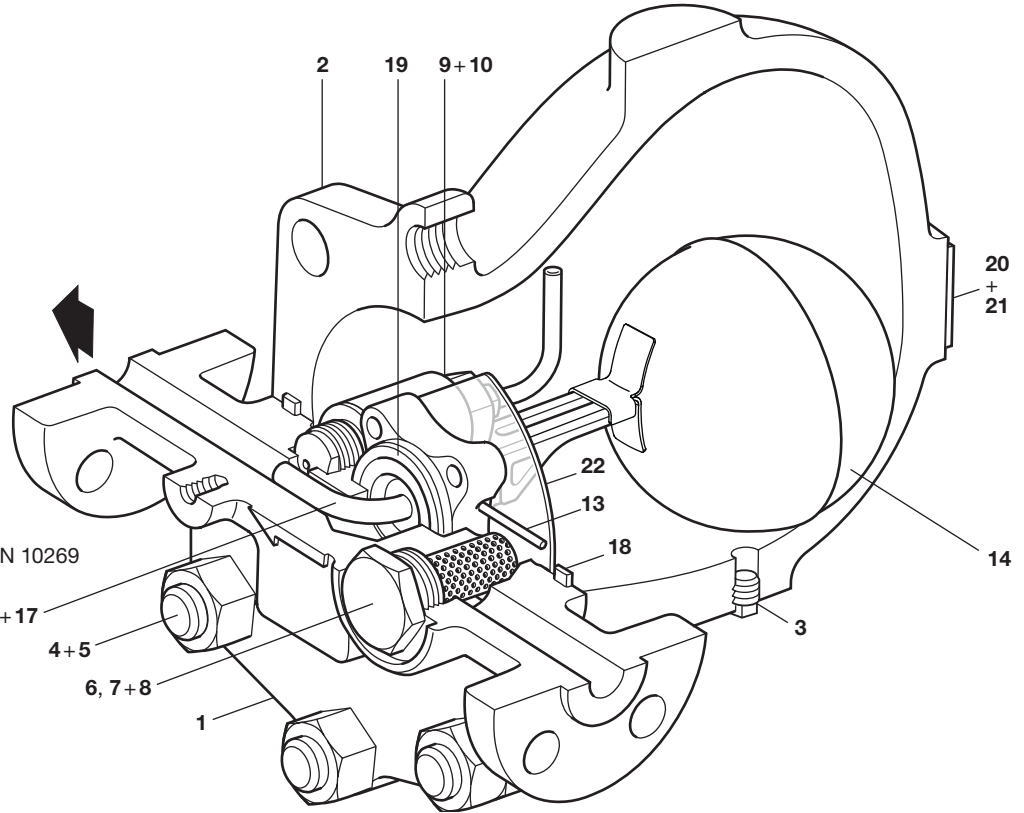

The material used for the studs and nuts upon all versions is :

- Studs = ASTM A193 B7
- Nuts = ASTM A194 Gr. 4 to EN 10269

11, 12, 15, 16 +17

* **Please note** that part numbers 11, 12, 15 and 16 are more clearly identified on the spares illustration on page 6.

Materials

No.	Part	Material	
1	Body	Carbon steel	EN 10213 1.0619+N / ASTM A216 WCB
2	Cover	Carbon steel	
3	3/8" NPT taper plug	Stainless steel	CF8 / 1.4308 or 1.4301 / 304
4	3/4" UNF nut (x6)	Carbon steel	ASTM A194 Gr. 4
5	3/4" UNF studs x 85 mm long (x6)	Carbon steel	ASTM A193 B7
6	Strainer cap	Stainless steel	CF8 / 1.4308 or 1.4301 / 304
7	Strainer screen	Stainless steel	AISI 316L
8	'S' type gasket	Stainless steel	AISI 304
9	Air vent assembly	Stainless steel	AISI 431 S29 + 303
10	Air vent tube	Stainless steel	ASTM A269 304L
*11	Seat clamp	Stainless steel	CF8 / 1.4308 or AISI 303
*12	M6x30 long cap screw (x4)	Stainless steel	EN 150 3506-1
13	Pivot pin	Stainless steel	ASTM A276 304
14	Float assembly	Stainless steel	AISI 304L
*15	1/2" Ø ball	Stainless steel	AISI 316
*16	Conical spring	Stainless steel	Gr. 302 S26 Gr. 1
17	Valve seat and discharge pipe assembly	Stainless steel	AISI 431 S29 + 304L
18	Spirally wound gaskets	Body to Cover and Seat to Body	Graphite filler + 304 stainless strip
19			
20	Name-plate	Stainless steel	204
21	Hammer drive screws (x 2)	Stainless steel	18-8
22	Baffle plate	Stainless steel	304L

TI-P179-13-US 10.16

Pressure / temperature limits (ISO 6552) - Screwed and Socket weld

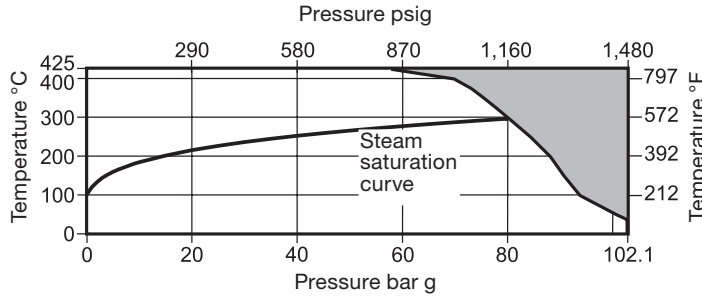

The product must not be used in this region or beyond the parameter of the PMA or TMA of the relative end connection..

Body design condition	ASME Class 600	
PMA Maximum allowable pressure	1480 psig @ 100°F (102.1 bar g @ 38°C)	
TMA Maximum allowable temperature	797°F @ 834 psig (425°C @ 57.5 bar g)	
Minimum allowable temperature	-20°F (-29°C)	
PMO Maximum operating pressure for saturated steam service	1160 psig @ 465°F (80 bar g @ 296°C)	
TMO Maximum operating temperature	797°F @ 834 psig (425°C @ 57.5 bar g)	
Minimum operating temperature	32°F (0°C)	
Note: For lower operating temperatures consult Spirax Sarco		
Minimum operating differential pressure	1.5 psig (0.1 bar g)	
PMX Maximum differential pressure	FTC62-46	667 psig (46 bar)
	FTC62-62	900 psig (62 bar)
Designed for a maximum cold hydraulic test pressure of:	2,221 psig (153.2 bar g)	

Screwed Socket weld

Pressure / temperature limits (ISO 6552) - Flanged ASME

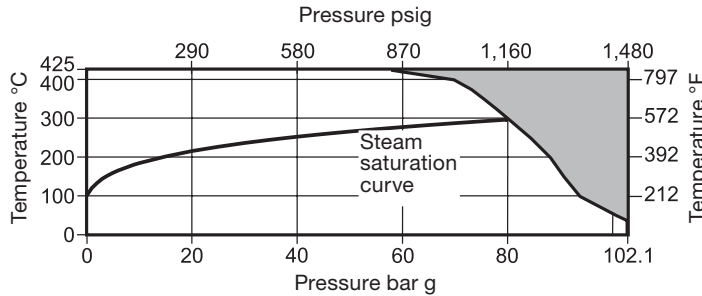

The product must not be used in this region or beyond the parameter of the PMA or TMA of the relative end connection..

Body design condition	ASME Class 600	
PMA Maximum allowable pressure	1440 psig @ 100°F (102.1 bar g @ 38 °C)	
TMA Maximum allowable temperature	797°F @ 812 psig (425 °C @ 57.5 bar g)	
Minimum allowable temperature	-20°F (-29 °C)	
PMO Maximum operating pressure for saturated steam service	915 psig @ 536°F (80 bar g @ 296 °C)	
TMO Maximum operating temperature	32°F (425 °C @ 57.5 bar g)	
Minimum operating temperature	32°F (0 °C)	
Note: For lower operating temperatures consult Spirax Sarco		
Minimum operating differential pressure	1.5 psig (0.1 bar g)	
PMX Maximum differential pressure	FTC62-46	667 psig (46 bar)
	FTC62-62	900 psig (62 bar)
Designed for a maximum cold hydraulic test pressure of:	2,161 psig (153.2 bar g)	

Flanged ASME Class 600

FTC/FTS62 Capacity, Hot Condensate

Pressure psig (barg)	Flow in lb/hr (kg/hr)	
	667 psig (46 barg) Mechanism	900 psig (62 barg) Mechanism
22 (1.5)	705 (320)	375 (170)
145 (10)	1323 (600)	1146 (520)
290 (20)	1698 (770)	1433 (650)
435 (30)	2072 (940)	1720 (780)
580 (40)	2425 (1100)	2017 (915)
667 (46)	2646 (1200)	2189 (993)
725 (50)		2304 (1045)
870 (60)		2590 (1175)
900 (62)		2646 (1200)

Capacities shown above are based on condensate at saturation temperature. Under start-up conditions when condensate is cold the internal bi-metallic air vent will be open and provides additional capacity to the main valve. **The table (to right) gives the minimum additional cold water capacities from the air vent on all sizes.**

P psi (bar)	22 (1.5)	145 (10)	435 (30)	667 (46)	900 (62)
FTC62	Minimum additional cold water capacity lb/hr (kg/h)				
667 psi (46 bar version)	44 (20)	939 (426)	1182 (536)	1764 (800)	
900 psi (62 bar version)	44 (20)	772 (350)	970 (440)	2050 (930)	1764 (800)

Note: The Air vent closing temperature range = 248°F to 275°F (120°C to 135°C)
For differential pressures less than 22 psig (1.5 bar g), the additional cold water capacity is minimal.

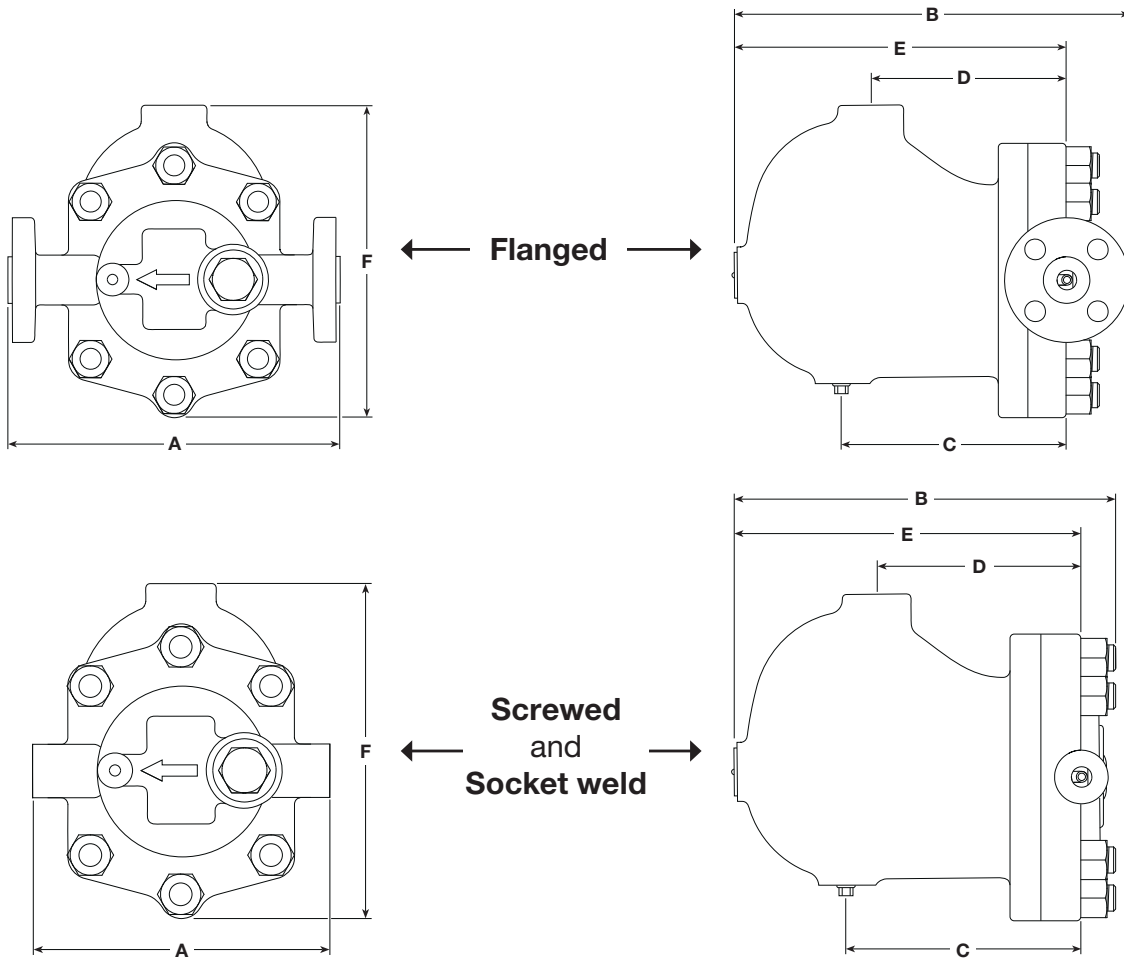

Dimensions / weights (approximate) in inches (mm) and pounds (kg)

Size	Flanged - ASME 600			Screwed and Socket Weld			Common Dimensions			
	A	B	Weight	A	B	Weight	C	D	E	F
1/2"	10.3 (261)	11.8 (299)	52.9 (24)	7.5 (190)	11.3 (287.5)	48.5 (22)	6.8 (172.5)	5.8 (148)	9.9 (251.5)	9.4 (239)
3/4"	10.7 (271)	12.2 (309)	56.2 (25.5)	7.5 (190)	11.3 (287.5)	48.5 (22)	6.8 (172.5)	5.8 (148)	9.9 (251.5)	9.4 (239)
1"	11.5 (291)	12.4 (314)	59.5 (27)	7.5 (190)	11.3 (287.5)	48.5 (22)	6.8 (172.5)	5.8 (148)	9.9 (251.5)	9.4 (239)

TI-P179-13-US 10.16

Safety information, installation and maintenance

For full details see the Installation and Maintenance Instructions (IM-P179-15) supplied with the product.

Installation note

The FTC62 must be installed with the direction of flow as indicated on the body, and with the float arm in a horizontal plane so that it rises and falls vertically.

Disposal

This product is recyclable. No ecological hazard is anticipated with the disposal of this product, providing due care is taken.

How to order

Example: 1 off Spirax Sarco 1/2" FTC62-62 L-R ball float steam trap, flanged to ASME 600 with carbon steel body and cover and thermostatic air vent.

Example: 1 - Maintenance kit for a Spirax Sarco 1/2" FTC62-62 ball float steam trap.

Spare parts

The spare parts available are shown in solid outline. Parts drawn in a grey line are not supplied as spares.

Available spares



Body / cover gasket kit	18
Air vent assembly + Air vent tube	9 and 10
Strainer screen + 'S' type gasket	7 and 8
1/8" NPT taper plug	3
Cap screw (x 4)	12
Pivot pin	13
Float assembly	14
Maintenance kit 1/2" Ø ball	15
Conical spring	16
Valve seat and discharge pipe assembly	17
'S' type gasket + Spirally wound gaskets	8, 18 and 19
Baffle plate	22
Rebuild kit	3, 7, 8, 9, 10, 12, 13, 14, 15, 16, 17, 18, 19 and 22

How to order spares

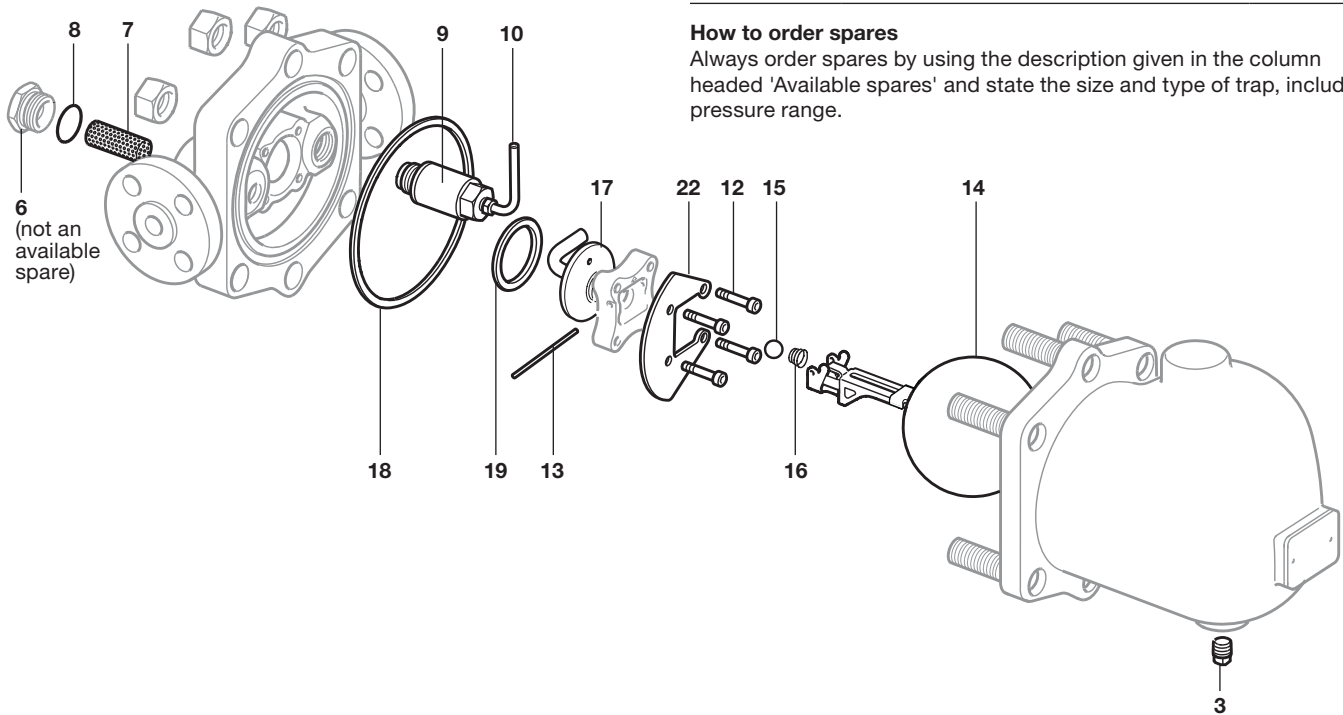
Always order spares by using the description given in the column headed 'Available spares' and state the size and type of trap, including pressure range.



Recommended tightening torques

Item	Part		Inch or mm		N m	lbf ft
3	1/8" NPT Square head plug		11 mm A/F	1/8" NPT	As required	
4	3/4" UNF Hex. Nut		1.125" A/F	3/4" UNF	252-260	186-192
6	Strainer cap		32 mm A/F	M28 x 1.5	170-190	125-140
9	Air vent assembly		24 mm A/F	M22 x 1.5	80-88	59-65
10	Air vent tube assembly		11 mm A/F	M10 x 1.5	10-12	7-9
12	Socket head cap screw		5 mm A/F (Hex Key)	M6	14-16	10-12

TI-P179-13-US 10.16