



CSG Series - Clean Steam Generator (Unfired Steam Generator)

Description

The Spirax Sarco Clean Steam Generator (CSG) is designed to provide sterilization grade clean steam from suitably treated feed water using plant steam as the energy source. Units using other primary fluids on the heating media can be provided to special order.

The skid mounted CSG units are supplied with water level control, primary steam control and other essential equipment required for efficient operation. The units are factory assembled and tested to allow for minimal installation time, trouble free commissioning and operation.

Common application for Clean Steam Generator are for humidification, sterilization, food processing, pharmaceuticals, laboratories and clean room applications.

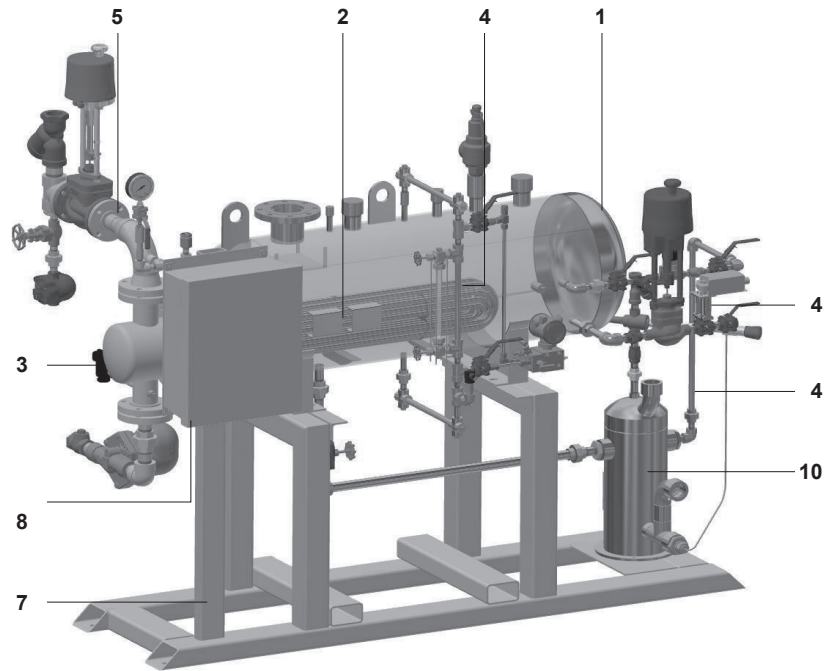

Pressure/Temperature Limits

	Primary side – Plant steam (Tube Bundle)		Secondary side – Clean steam (Shell Side)	
PMA (Maximum allowable pressure)	150 psi g	(10.3 bar g)	150 psi g	(10.3 bar g)
TMA (Maximum allowable temperature)	366 °F	(185.5 °C)	366 °F	(185.5 °C)
PMO (Maximum operating pressure)	125 psi g	(8.6 bar g)	80 psi g	(8.6 bar g)
TMA (Maximum operating temperature)	353 °F Saturated	(178.2 °C) Saturated	323 °F	(162.2 °C)
Hydrotest pressure	195 psi g	(13.4 bar g)	195 psi g	(13.4 bar g)

Materials

No.	Part	Material
1	CSG vessel	Stainless steel 316
2	Steam coil/'U' tube bundle	Stainless steel 316
3	Tube head (Plant Steam)	Carbon steel
4	Clean steam piping/ Accessories	Stainless steel 316
5	Plant steam piping/ Accessories	Carbon steel/Equal
6	Gaskets	Laminated graphite/spiral wound SS304
7	Frame/skid	Carbon steel
8	Control Panel – NEMA 1	14 g steel
9	Insulation – CSG Vessel	2" thick mineral Fibre/ Smooth aluminum cladding
10	Condensate cooler (Optional equipment)	Stainless steel 316L

All clean steam wetted components will be stainless steel

Standards

- Pressure Vessel & Tube Bundle is designed and fabricated in accordance with ASME Section VIII Div. 1 and CRN registered.
- Control Panel is CSA certified and with native Bacnet firmware
- Package is assembled & Tested in TSSA approved facility

Standard documentation

- General arrangement drawing
- Control Schematic
- Operation – Maintenance Instruction
- ASME Data Report for Vessel
- CRN certificates for components/fittings

Recommended water quality

Spirax Sarco CSG's are capable of producing clean steam when supplied with make-up feed water deionized, reverse osmosis water or softened dechlorinated potable water.	PH	6.5-8.5
	Hardness	Absent
	Chlorine	Absent in all forms
	Conductivity	<600 ppm total dissolved solids

Testing

Spirax Sarco CSG generators are subjected to hot & wet functional test as per Factory Acceptance Test. All CSG series generators are Hydro tested & leak tested in factory.

Optional equipment

- Blow down/condensate cooler
- Automatic surface blowdown based on conductivity
- Steam meter and water meter
- Clean steam separator

Control panel and automation

Touchscreen control panel displays

- Operating pressure psi g
- Pressure set point psi g
- Feed water valve status
- High water cutoff valve status
- Plant steam valve position (%)
- Level indication (%)
- Enable/disable switch status
- Startup/normal mode display
- High-Low water alarms
- High pressure alarms
- Trend log for valve position and clean steam pressure
- Controls overview

All controller variables available through Bacnet communication protocol

Control panel features and alarms

- Password protected user level
- Remote start stop
- On-Off switch
- High pressure cut-out and alarm
- Low pressure alarm
- Control loop configuration screen
- Controller output (PID)
- Conductivity blowdown functionality – Optional feature
- Native Bacnet communication
- General alarm output
- Low water
- High water
- Low pressure
- High pressure

Capacities

See new TI-CSG-Capacity

Clean steam generator schematic

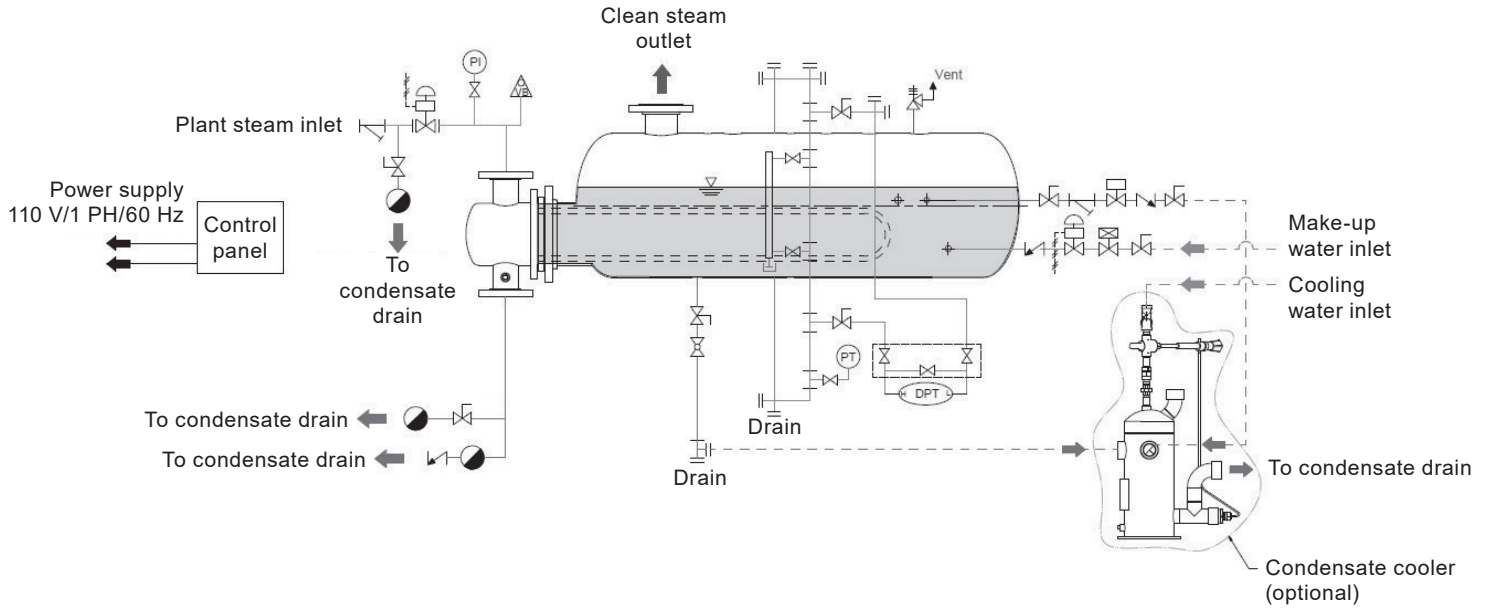

Key

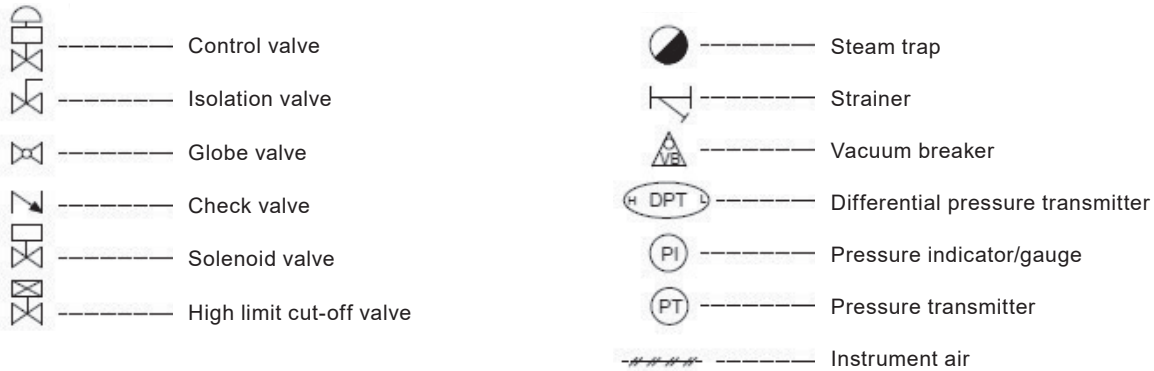

Dimensions/weights (approx inches/lbs)

Model #	Vessel Size Dia. X L (inch)	L Length (Inch)	W Width (Inch)	H Height (Inch)	Dry weight (lbs)	Operating weight (lbs)
CSG-xx -60-xx	20" x 48"	90	56	84	2000	2400
CSG-xx -120-xx	24" x 60"	110	56	88	2200	3000
CSG-xx-205-xx	30" x 72"	116	56	92	2600	3975
CSG-xx-395-xx	36" x 96"	120	56	96	3250	5800

