

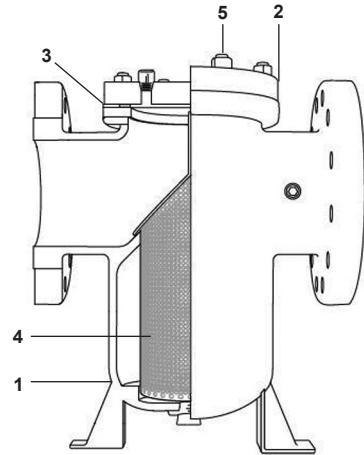

Carbon Steel Basket Strainers 734

| | | |
|----------------------------------|--------------|-----------|
| Type | 734-150 | 734-300 |
| Sizes | 2" to 12" | |
| Connections | ANSI 150 | ANSI 300 |
| Construction | Carbon steel | |
| Maximum saturated steam pressure | 203 psi g | 604 psi g |
| Standard screen | | |
| Steam | 2" to 8": | .045 perf |
| | 10" to 12": | .125 perf |
| Liquid | 2" to 4": | .063 perf |
| | 6" and up: | .125 perf |



Type 734-150

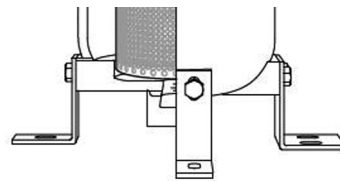

Supporting brackets for Type 734-300

Limiting operating conditions (non-shock)

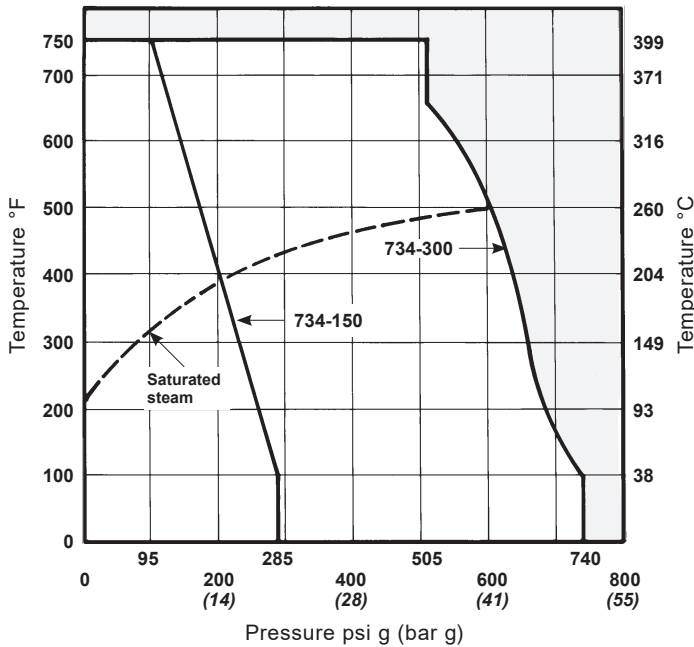

Referenced standards and codes

| Code | Description |
|-----------------|---|
| ASME/ANSI B16-5 | Pipe flanges, flanged fittings and body |

*Note: Strainers are not ANSI stamped as standard.

Construction materials

| No. | Part | Material | |
|-----|-----------------|---|-------------------|
| 1 | Body | Carbon steel | ASTM A216 Gr. WCB |
| 2 | Cover | Carbon steel | ASTM A216 Gr. WCB |
| 3 | Cover gasket | Spiral wound, stainless steel, non asbestos | |
| 4 | Strainer screen | Stainless steel | Type 304 |
| 5 | Cover studs | Alloy steel | A193 Gr. B7 |
| | Nuts | Carbon steel | A194 Gr. 2H |

Pressure shell design conditions

ANSI CLASS 150 734-150

| | |
|------------------------|-----------------|
| WOG (water, oil, gas): | 285 psi @ 100°F |
| Saturated steam: | 150 psi @ 366°F |
| Maximum liquid: | 80 psi @ 800°F |

ANSI CLASS 300 734-300

| | |
|------------------------|-----------------|
| WOG (water, oil, gas): | 740 psi @ 100°F |
| Saturated steam: | 300 psi @ 420°F |
| Maximum liquid: | 400 psi @ 800°F |

C_v values (GPM)

| Size | C _v |
|------|----------------|
| 2" | 43 |
| 2½" | 86 |
| 3" | 135 |
| 4" | 290 |
| 6" | 780 |
| 8" | 1600 |
| 10" | 3250 |
| 12" | 5200 |

For water:

$$\text{Pressure drop} = \frac{(\text{GPM})^2}{(\text{Cv})^2}$$

Consult factory for other liquids.

See TI-7-429-US for pressure drops on steam, air and other gases.

Installation

The strainer should be installed with the flow direction as indicated on the body, in a horizontal pipeline. The strainer must be accessible for periodic removal and cleaning of the screen.

| | |
|--------|----------|
| Screen | 4 |
| Gasket | 3 |

Note: Please provide date code when placing order for spare parts. Contact Technical Support for assistance if needed.

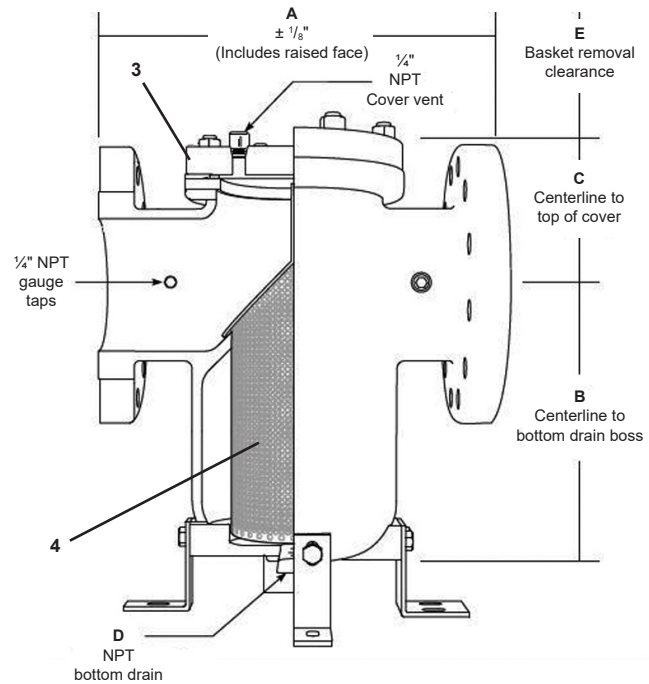

Dimensions (nominal) in inches (and millimeters)

| Size | ANSI 150 | ANSI 300 | ANSI 150 | ANSI 300 | ANSI 150 | ANSI 300 | NPT | ANSI 150 | ANSI 300 | Weight lb/kg | |
|--------|---------------------|----------|------------------------------|----------|---------------------------|----------|--------|----------|-----------------------|--------------|----------|
| | A (Face-to-face) | | B (Center-line to bottom) | | C (Center-line to top) | | | D | E (Screen removal) | | ANSI 150 |
| 2" | 8.50 | 8.50 | 5.88 | 6.13 | 5.00 | 4.91 | 1/2" | | 8.00 | 9.00 | 24.0 |
| | 216 | 216 | 150 | 156 | 127 | 125 | | 204 | 229 | 10.9 | 18.1 |
| 2 1/2" | 8.00 | 8.69 | 5.44 | 6.25 | 4.75 | 5.45 | 3/4" | 7.50 | 10.00 | 33.0 | 63.0 |
| | 204 | 221 | 139 | 159 | 121 | 139 | | 191 | 254 | 15 | 28.5 |
| 3" | 8.75 | 9.56 | 5.25 | 8.00 | 5.50 | 6.08 | 3/4" | 8.50 | 10.00 | 38.0 | 63.0 |
| | 223 | 243 | 134 | 204 | 140 | 155 | | 216 | 254 | 17.2 | 28.5 |
| 4" | 11.19 | 11.88 | 7.88 | 8.53 | 6.13 | 5.31 | 1" | 11.00 | 10.00 | 64.0 | 108.0 |
| | 285 | 302 | 201 | 217 | 156 | 135 | | 280 | 254 | 29 | 48.9 |
| 6" | 13.88 | 14.75 | 13.13 | 12.75 | 6.75 | 6.38 | 1-1/4" | 14.50 | 20.00 | 128.0 | 200.0 |
| | 353 | 375 | 334 | 324 | 172 | 162 | | 369 | 508 | 58 | 90.6 |
| 8" | 17.38 | 18.13 | 16.38 | 15.63 | 8.88 | 8.08 | 1 1/2" | 19.25 | 20.00 | 227.0 | 342.0 |
| | 442 | 461 | 416 | 397 | 226 | 206 | | 489 | 508 | 102.9 | 155 |
| 10" | 22.00 | 22.88 | 19.38 | 16.52 | 10.75 | 9.70 | 1 1/2" | 22.75 | 26.00 | 362.0 | 542.0 |
| | 559 | 582 | 493 | 420 | 274 | 247 | | 578 | 661 | 164 | 245.6 |
| 12" | 26.25 | 25.38 | 23.75 | 24.52 | 13.75 | 11.70 | 2" | 27.00 | 35.00 | 487.0 | n/a |
| | 667 | 645 | 604 | 623 | 350 | 298 | | 686 | 889 | 220.7 | n/a |