

spirax sarco

BX and BXRA Bronze Self-Acting Control Valves

Description

The BX range of two port valves are used in conjunction with Spirax Sarco SA control systems to provide a self-acting temperature control unit. Alternatively, they can be used as electrically actuated temperature control valves by fitting an EL3500 Series electric actuator with a suitable temperature transmitter and controller.

Available Types

BX Normally open single seat with four different orifice sizes: BX2, BX3, BX4 and BX6.

BXRA Normally closed, single seat.

Sizes and Pipe Connections

½" screwed NPT. (Option: BSP)

Limiting Operating Conditions

Maximum Differential Pressure

BX	250 psi*	17 bar
BXRA	150 psi	10 bar

* On liquid applications, the permissible maximum differential pressure may be affected by high static pressure. Please consult the factory if the application requires a large differential pressure with a high inlet pressure.

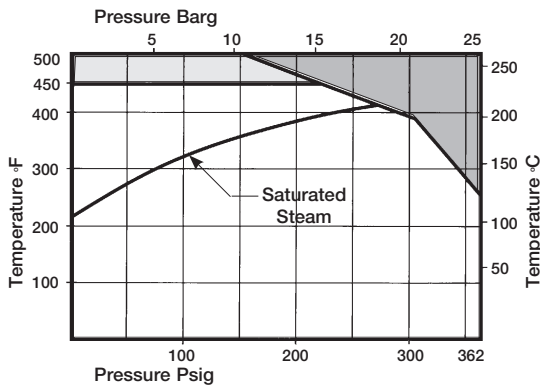

If the valve is to be used in this region, a spacer (stock #0467000) must be fitted between the valve and the control system to protect the control system from overheating.

The valves must not be used in this region

The valves may be used in this region provided that the above maximum differential pressures are not exceeded. Valves with ANSI flanges must not be used above flange limits.

SHUTOFF: ANSI CLASS IV

Pressure Shell Design Conditions

PMA	362 psig/248°F	25 barg/120°C
Max. allowable pressure	253 psig/428°F	17.5 barg/220°C
	152 psig/500°F	10.5 barg/260°C

TMA	500°F/0-152 psig	260°C/0-10.5 barg
Max. allowable temperature		

Typical Applications

Industrial or commercial applications using steam or hot water as a heating medium, or water for cooling.

BX Valve

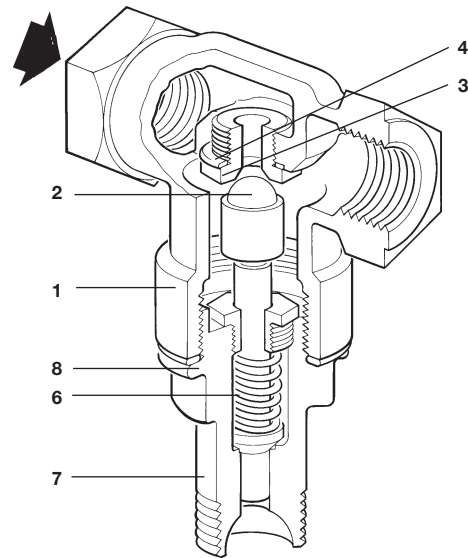

BXRA Valve

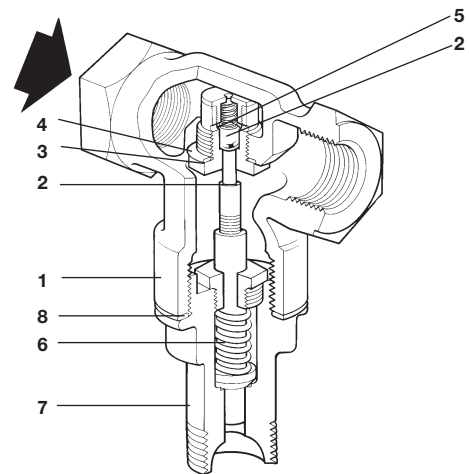

Construction Materials

No.	Part	Material	Material Spec.	Closest Equivalent
1	Body	Bronze	BS 1400 LG2	ASTM B62
2	Valve	Stainless Steel		
3	Valve Seat	Stainless Steel		
4	Valve Seat Gasket	Copper		
5	Ball Return Spring	Stainless Steel		
6	Main Return Spring	Stainless Steel		
7	Bonnet	Brass		
8	Bonnet Gasket	Nickle Reinforced Exfoliated Graphite		

Local regulation may restrict the use of this product below the conditions quoted. Limiting conditions refer to standard connections only. In the interests of development and improvement of the product, we reserve the right to change the specification.

BX and BXRA Bronze Self-Acting Control Valves

Dimensions (nominal) in inches and millimeters

Size	A	B	Weight
½"	3.2	3.3	1.5 lb
(DN15)	80	83	0.7 kg

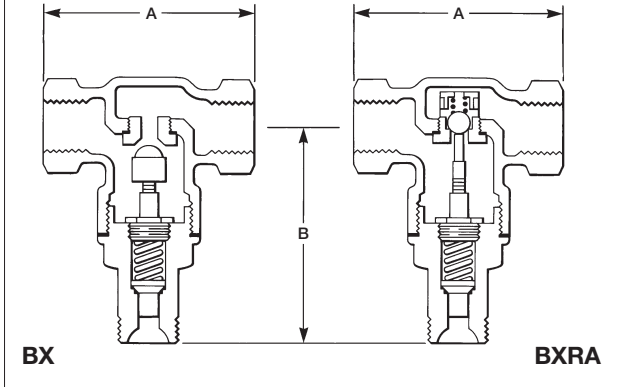

C_v at P Band*

Valve	BX2	BX3	BX4	BX6	BXRA
C _v	0.44	0.74	1.20	1.92	0.66
P Band (°F)*	5.4°	8°	8°	8°	8°

* The proportional band (P Band) is the difference required between the desired set temperature and the actual controlled temperature to open the valve fully. The above figures apply to valves fitted with 121 or 123 control systems. For 122 or 128 systems, the P Band will be twice the amount shown.

Example: For a BX3 valve with a 122 control system, the valve will not fully open until the controlled temperature drops to 16°F below the set point.

Capacities

For saturated steam sizing capacities, see TI-1-011-US. For water sizing capacities, see TI-1-012-US.

Sample Specification

Control valve shall be bronze body with stainless steel trim. Valve is coupled to the appropriate temperature control system. This combined unit is self acting and provides proportional control action. The temperature control system shall be brass with PVC covered capillary or stainless steel sensor and capillary, oil filled, hydraulically operated; and shall incorporate packless glands and a gas filled overheat protection device. Temperature setting shall be adjustable while control is in service, include °F adjustment scale and shall incorporate a tamper proof device. When required, sensor bulb shall be mounted in a separable well for removal from the equipment. Refer to TI-1-900-US or TI-1-901-US for temperature control system details.

Installation

The valve should be installed in a horizontal section of the heating or cooling medium inlet piping. The control system connection must point vertically downward. A bypass with suitable stop valves should be provided to permit servicing, and a Y-pattern strainer should be installed upstream of the valve. If the valve is smaller than the pipeline, eccentric reducers should be used. In a steam system, a steam trap should be installed upstream of the valve to ensure that the steam entering the valve is as dry as possible.

Maintenance

Except for periodic cleaning of the upstream strainer, maintenance or servicing is normally required only if a malfunction is detected. Complete installation and maintenance instructions are given in the IM-S21-01 sheet, which accompanies the product.

Spare Parts

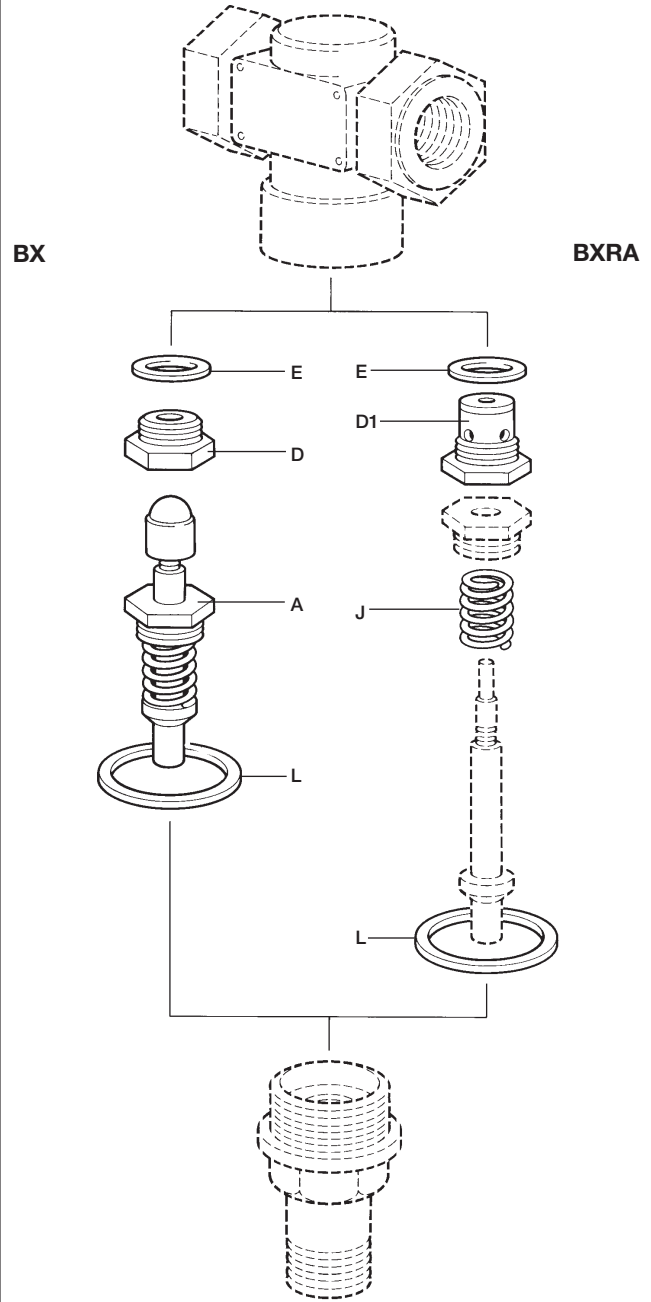

Valve & Seat Assembly (BX valve) L, A, D, E

Valve & Seat Assembly (BXRA valve) L, D1, E

Gasket Set (pkt of 3 each) L, E