

# spirax sarco®

## Air Eliminators AE30, AE30A

AE30 and AE30A Air Eliminators are designed to improve the circulation of pressurized liquids by eliminating air and other non-condensable gases which may collect at high points in the system. The AE30A has a check valve in the outlet orifice.

Model ↔	AE30 AE30A
<b>PMO</b>	116 psig
<b>Sizes</b>	1/2" x 1/4"
<b>Connections</b>	NPT
<b>Construction</b>	Brass Body Stainless Steel, Rubber and Plastic Internals
<b>Options</b>	BSP Connections

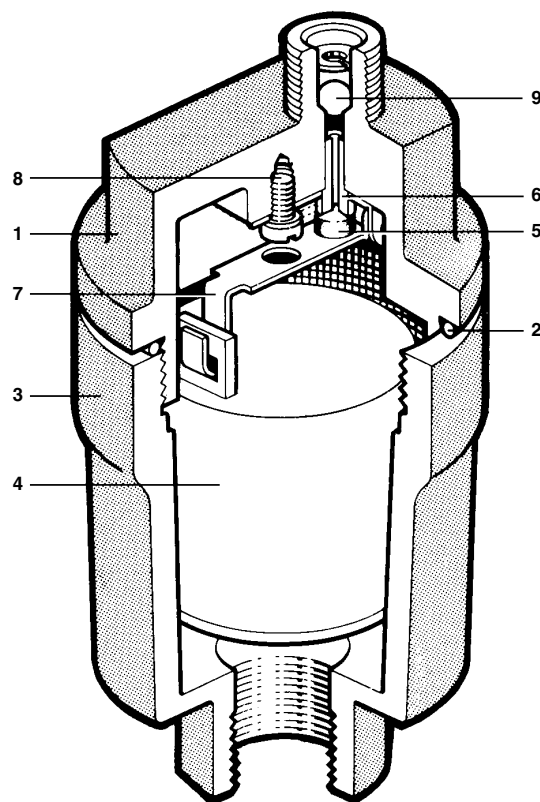

### CONSTRUCTION MATERIALS

No.	Part	Material	
1	Cap	Brass Alloy	Delta Alloy S10
2	Cap "O" Ring	Nitrile Rubber	
3	Body	Brass Alloy	Delta Alloy S10
4	Float	Plastic	
5	Valve	Viton Rubber	
6	Valve Seat	Stainless Steel	BS 970 431 S29
7	Bracket & Lever Assy.	Stainless Steel	BS 1449 304 S12
8	Bracket Screw 4 mm Cheese Head x 6 mm	Stainless Steel	BS 4183 18/8
9	Check Valve (for AE30CV)	Stainless Steel	AISI 440 B

### LIMITING OPERATING CONDITIONS

**Max. Operating Pressure (PMO)** 116 psig (8 barg)

**Max. Operating Temperature** 230°F (110°C)

### PRESSURE SHELL DESIGN CONDITIONS

**PMA** 145 psig/0-230°F 10 barg/0-110°C  
Max. allowable pressure

**TMA** 230°F/0-145 psig 110°C/0-10 barg  
Max. allowable temperature

### TYPICAL APPLICATIONS

Air vents can be used on both hot and cold liquid services. Typical applications are cold water lines, suction lines to pumps, mixing tanks, condensate return lines, cooling water lines on air compressors, and water storage tanks.

*Local regulation may restrict the use of this product below the conditions quoted. Limiting conditions refer to standard connections only.*

*In the interests of development and improvement of the product, we reserve the right to change the specification.*

# Air Eliminators AE30, AE30A

## AIR CAPACITY (discharge to atmosphere)

SCFM cubic feet per minute at standard conditions of 14.7 psia at 60°F. For dm<sup>3</sup>/s multiply by .4719.

	Inlet Pressure				
	psi	25	50	75	100
	bar	1.7	3.4	5.2	6.9
Capacity		1.5	2.7	3.9	5.0

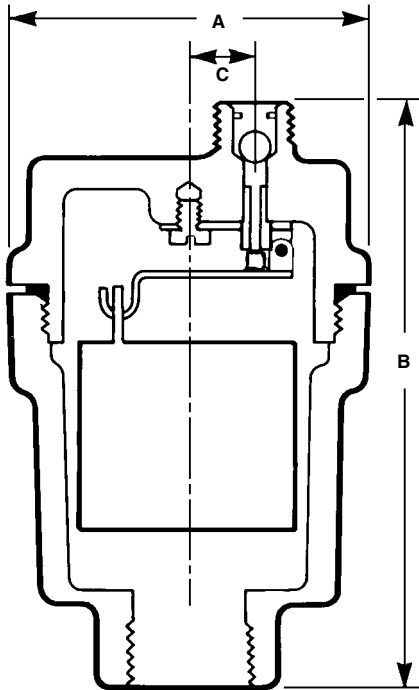

### DIMENSIONS (NOMINAL) IN INCHES AND MILLIMETERS

Size Inlet	Outlet	A	B	C	Weight
1/2	1/4	2.2	4.1	0.40	1.5 lb
		56	105	10	0.7 kg

## MAINTENANCE

This product can be maintained without disturbing the inlet piping connection. Complete isolation is required before any servicing is performed.

The air vent should be disassembled periodically for inspection and cleaning of the valve head and seat and operating mechanism. Worn or damaged parts should be replaced using a complete set of internals.

**Complete installation and maintenance instructions are given in IMI 4.006, which accompanies the product.**

## SAMPLE SPECIFICATION

Automatic Air Eliminators shall be mounted at high points to provide for immediate removal of contained air or other non-condensable gases in liquid piping systems. They shall be of the float type design having brass body with threaded connections, valve head shall be of viton rubber material to provide positive shut-off. Air vent shall have a minimum venting capacity of 5.0 SCFM at 100 psig.

## INSTALLATION

An air vent is required at all high points of a liquid system, on terminal equipment and wherever air can collect. The air vent must be installed vertically above the piping with the inlet at the bottom so that the float mechanism is rising and falling in the vertical plane. The inlet piping should be the same size as the piping connection on the body, and a full-port isolating valve should be installed upstream of the air vent. As with all air vents, dribbling may occur if the valve becomes fouled with dirt. For this reason, it is recommended that a pipe be fitted to the outlet discharge to drain or to a safe place where damage cannot occur.

### SPARE PARTS

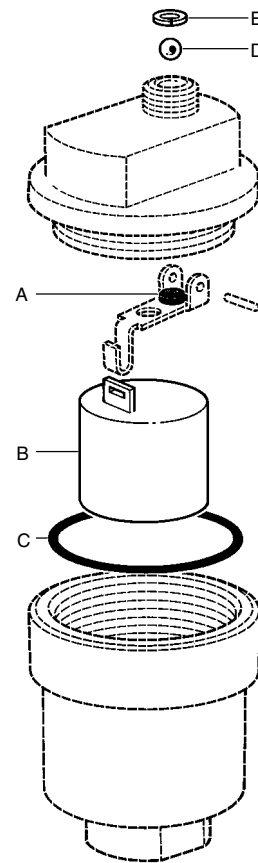

Set of Internals

A, B, C, D, E