

spirax sarco

Pilot Operated Temperature Regulators 1/2" to 4" 25T

The 25T is a self actuated pilot-operated temperature regulating valve. The temperature pilot has a calibrated dial for accurate temperature setting, and is available with a variety of solid-fill sensing bulbs (see TI-1-1123-US). The standard capillary tubing length is 8 feet, with an optional standard length of 15 feet.

Model	25T			
Sizes	1/2" to 2"	2 1/2", 3", 4"	1/2" to 2"	2", 2 1/2", 3", 4"
Connections	NPT	ANSI 125 flgd.	NPT	ANSI 300 flgd.
Construction	Cast Iron		Cast Steel	
Options		ANSI 250 flgd.		ANSI 150 flgd. (excludes 2")
	Non-Standard capillary tubing length (see TIS 1.1123) in 5 ft. intervals to a maximum of 50 ft.			

Typical Applications

Storage steam water heaters, instantaneous heat exchangers and converters, air handling coils, tank heating coils, steam jacketed vessels, steam chests, molds and platens.

Capacities

For selection and sizing data, see TI-1-1124-US.

Limiting Operating Conditions

Max. Operating Pressure (PMO)	NPT: 250 psig (17 barg) @ 450°F (232°C)	ANSI 125: 125 psig (8 barg) @ 450°F (232°C)	ANSI 250: 250 psig (17 barg) @ 450°F (232°C)	ANSI 150: 185 psig (12 barg) @ 450°F (232°C)	ANSI 300: 300 psig (20 barg) @ 450°F (232°C)
Max. Operating Temperature*	450°F (232°C)	*The temperature of the sensing bulb must not exceed 350°F (177°C)			

Standard Temperature Ranges

30°F to 90°F (0°C to 32°C)	100°F to 160°F (40°C to 70°C)
60°F to 120°F (15°C to 50°C)	160°F to 220°F (70°C to 105°C)
120°F to 180°F (50°C to 80°C)	260°F to 320°F (125°C to 160°C)
200°F to 260°F (95°C to 125°C)	

Pressure Shell Design Conditions

PMA	Cast Iron: 250 psig/0-450°F 17 barg/0-232°C
Max. allowable pressure	Cast Steel: 300 psig/0-450°F 20 barg/0-232°C

TMA	Cast Iron: 450°F/0-250 psig 232°C/0-17 barg
Max. allowable temperature	Cast Steel: 450°F/0-300 psig 232°C/0-17 barg

Sample Specification

Temperature Regulators shall be of the pilot-actuated, diaphragm-operated type. The main valve shall be single-seated, with hardened stainless steel trim; the valve body shall be cast iron (cast steel). The pilot shall be bolted directly to the valve body and shall be removable without disturbing the control connections. The temperature setting shall be adjustable without the use of tools, and the set point shall be indicated on a calibrated dial. The thermostatic system shall be solid fill, and shall incorporate overheat protection.

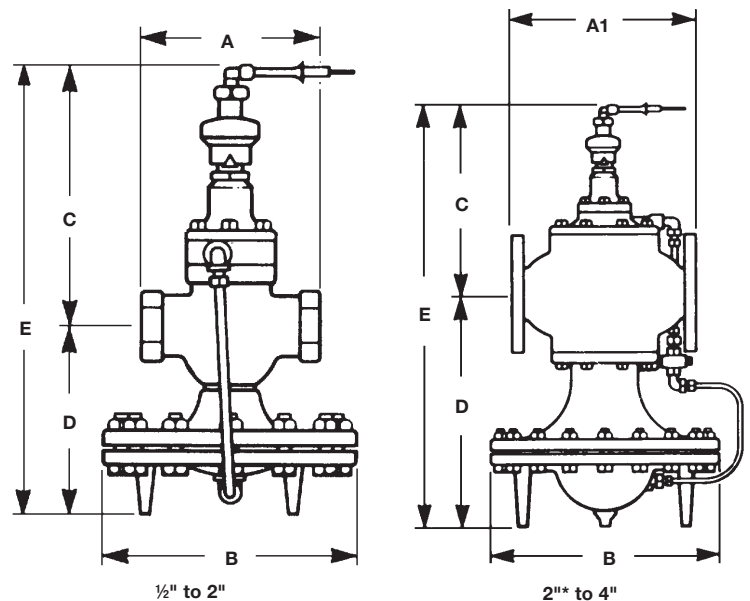

Dimensions (nominal) in inches and millimeters

Size	Ansi 125		Ansi 250		C	D	E	Weight	
	A	A1	A1	B				Cast Iron	Cast Steel
1/2", 3/4"	5.5	-	-	7.6	9.8	6.2	16.0	27 lb	30 lb
	140	-	-	194	249	157	406	12.2 kg	13.6 kg
1"	6.0	-	-	8.6	9.75	6.75	16.5	34 lb	37 lb
	152	-	-	219	248	171	419	15.4 kg	16.8 kg
1 1/4", 1 1/2"	7.25	-	-	8.6	10.3	7.1	17.4	39.5 lb	43 lb
	184	-	-	219	262	179	441	17.9 kg	19.5 kg
2"	8.5	-	9.0	10.6	10.9	8.2	19.1	64 lb	70 lb
	216	-	228	270	278	208	486	29 kg	31.8 kg
2 1/2"	-	10.9	11.5	13.6	11.7	13.9	25.6	152.5 lb	166 lb
	-	276	292	346	297	354	651	69.2 kg	75.3 kg
3"	-	11.75	12.5	13.6	11.6	14.4	26.0	183.5 lb	200 lb
	-	298	318	346	294	367	660	83.2 kg	90.7 kg
4"	-	13.9	14.5	15.6	12.8	16.1	28.9	279.5 lb	305 lb
	-	352	368	397	325	410	735	127 kg	138 kg

Local regulation may restrict the use of this product below the conditions quoted. Limiting conditions refer to standard connections only.

In the interests of development and improvement of the product, we reserve the right to change the specification.

TI-1-1116-US 4.12

Pilot Operated Temperature Regulators

1/2" to 4" 25T

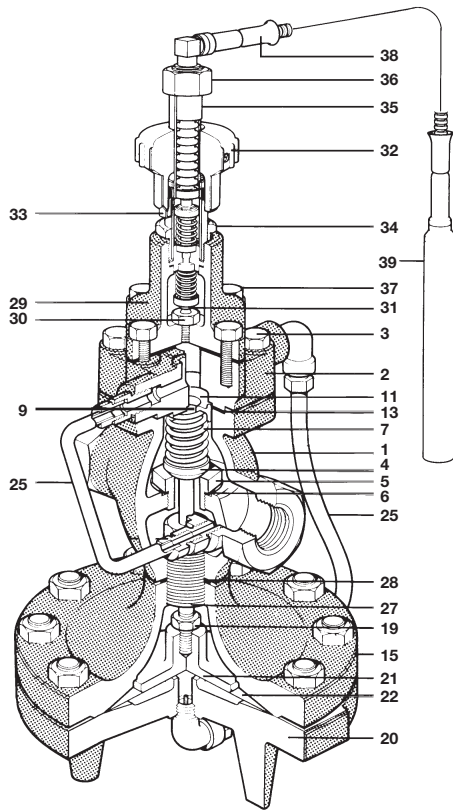

1/2" to 2"

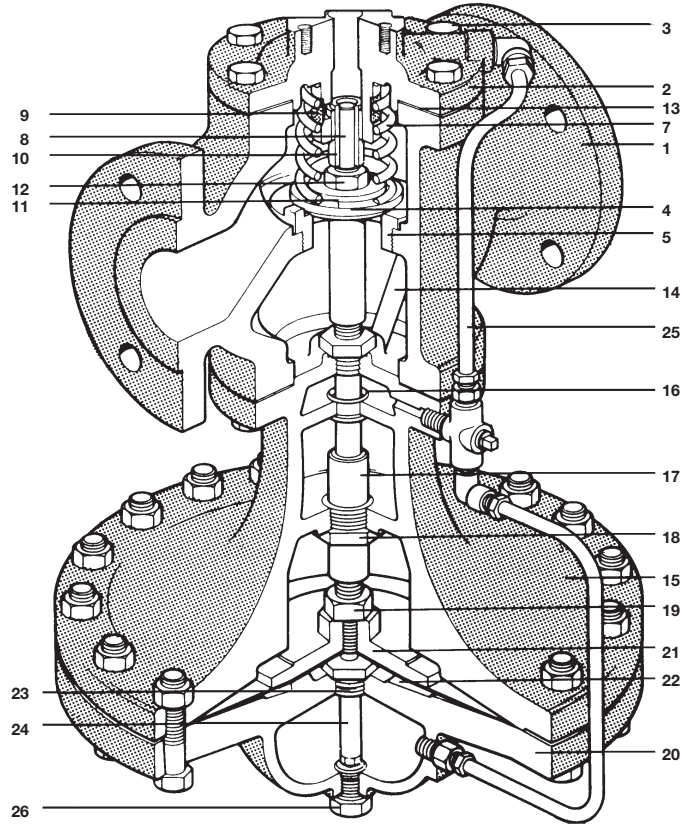

2" to 4" *ANSI 300 ONLY

Construction Materials

No.	Part	Material
1	Valve Body	Cast Iron ASTM A 126 CL B
		Cast Steel ASTM A216 Gr WCB
2	Cover	Cast Iron ASTM A 126 CL B
		Cast Steel ASTM A216 Gr WCB
3	Cover Bolts	Steel ASTM A449
4	Main Valve Head	Stainless Steel,
5	Main Valve Seat	Stainless Steel
6	Main Valve Seat Gasket	Copper
7	Valve Return Spring	Stainless Steel
8	Valve Stem	Stainless Steel
9	Strainer Screen	Stainless Steel
10	Valve Stem Sleeve	Stainless Steel
11	Spring Guide	Cast Iron 1/2"-2" CRS 2** - 4"
12	Nut	Steel
13	Cover Gasket	Graphite
14	Pressure Equalizer Pipe	Stainless Steel
15	Upper Diaphragm Case	Cast Iron ASTM A 126 CL B
		Cast Steel ASTM A216 Gr WCB
16	Stem Bushing (2 1/2" - 4" Cast Steel only)	Stainless Steel
17	Diaphragm Plate Stem	Stainless Steel
18	Diaphragm Stem Guide	Stainless Steel
19	Nut	Brass 1/2" - 2" Steel 2** - 4"
20	Lower Diaphragm Case	Cast Iron
		Cast Steel
21	Diaphragm Plate	Brass 1/2" - 2" C.I. 2** - 4"
22	Main Diaphragm (2 ply)	Stainless Steel
23	Bushing	CRS
24	Tube & Orifice	Stainless Steel

25	Tubing Assembly	Copper
		Brass
26	Plug (Cast Iron) (Cast Steel)	Brass
		Steel
27	Connector Stud	Stainless Steel
28	Body Gasket	1/2" - 2" Copper Clad
		2" - 4" Graphite
29	Pilot Valve Body	Cast Iron ASTM A 126 CL B
		Cast Steel ASTM A216 Gr WCB
30	Pilot Valve Seat	Stainless Steel
31	Pilot Valve Head	Stainless Steel
32	Adjustment Knob	Phenolic
33	Pointer	Stainless Steel
34	Extension Nut	Brass
35	Case Tube	Brass
36	Retaining Nut	Brass
37	Pilot Mounting Screws	Steel
38	Capillary Tube	Varies with style selected
39	Bulb	Varies with style selected
60	Pilot Gasket	Stainless Steel

Installation

The regulator should be installed in a horizontal line with suitable bypass and isolating valves. A steam trap should be installed upstream to prevent condensate from reaching the valve. The trap and regulator should both be protected with a strainer. The thermostatic bulb must be carefully located in the medium being heated. Complete installation instructions are given in IM-1-1116-US.

Maintenance

Complete installation and maintenance instructions are given in IM-1-1116-US, a copy of which is supplied with each valve. Available spare parts are shown on TI-1-1120-US and TI-3-0271-US.

TI-1-1116-US 4.12