



Combination Pressure/Temperature Regulator with Electric Override 1/2" to 4" 25PTE

Description

The 25PTE has all of the features of the 25PT pressure/temperature regulator, with the addition of an electric pilot which permits an electrical signal to override the temperature and pressure pilots to provide a remote shut-off capability.

*Note: For pressures below 15 psi g (1 bar g), the E pilot is not recommended for use with valves 2 1/2" (DN65) and larger.

Model	25PTE			
Sizes	1/2" to 2" (DN15 to DN50)	2 1/2", 3", 4" (DN65, DN80, DN100)	1/2" to 2" (DN15 to DN50)	2", 2 1/2", 3", 4" (DN50, DN65, DN80, DN100)
Connections	NPT	ANSI 125	NPT	ANSI 300
Construction	Cast iron		Cast steel	
		ANSI 250		ANSI 150 (excludes 2")
Options	Standard capillary tubing available 8' and 15' lengths. Contact the factory for non-standard capillary tubing lengths available in 5' increments, up to 50' (15m). (see TI-P235-07-US)			
Transmission Tubing	Copper Tubing		Stainless Steel Tubing	
Electric pilot specifications	Enclosure: NEMA 2, 3, 3S, 4, & 4X 120 VAC / 60 Hz Holding: 23 VAC Inrush: 45 VAC Normally Closed PMO: 200 psi g (13.8 bar g) TMO: 388 °F (198 °C)			
Electric pilot options	Enclosure: NEMA 2, 3, 3S, 4, & 4X 120 VAC / 60 Hz Holding: 23 VAC Inrush: 45 VAC Normally Closed PMO: 140 psi g (9.7 bar g) TMO: 361 °F (183 °C)			

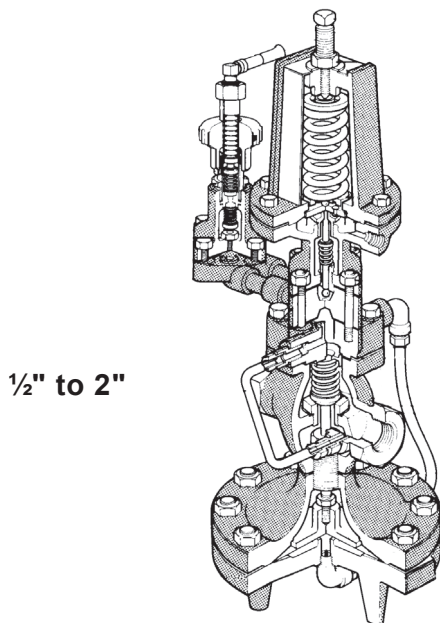

1/2" to 2"

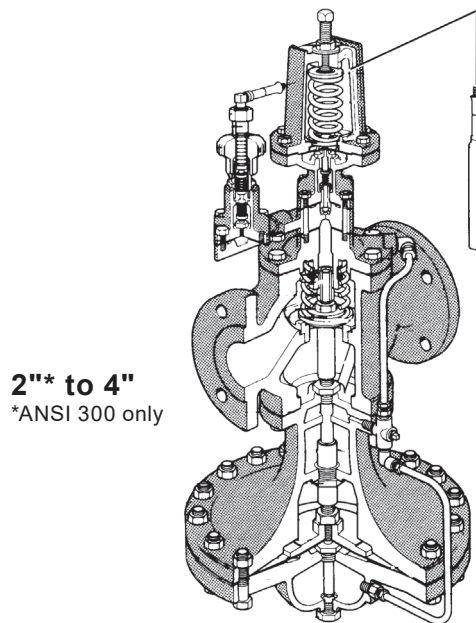

2" to 4"
 *ANSI 300 only

Typical applications

Pressure/Temperature control applications where the regulator must also respond to an electrical program timer, safety or limit switch, or remote manual switch.

Limiting operating conditions

	NPT:	200 psi g (14 bar g) @ 392 °F (200 °C)
	ANSI 125:	125 psi g (9 bar g) @ 392 °F (200 °C)
PMO	ANSI 250:	200 psi g (17 bar g) @ 392 °F (200 °C)
Maximum operating pressure	ANSI 150:	185 psi g (13 bar g) @ 392 °F (200 °C)
	ANSI 300:	200 psi g (14 bar g) @ 392 °F (200 °C)
Maximum operating temperature		392 °F (200 °C)

*The temperature of the sensing bulb must not exceed 350 °F (177 °C)

Standard temperature ranges

30 °F to 90 °F	(0 °C to 32 °C)
60 °F to 120 °F	(16 °C to 49 °C)
100 °F to 160 °F	(38 °C to 71 °C)
120 °F to 180 °F	(49 °C to 82 °C)
160 °F to 220 °F	(71 °C to 104 °C)
200 °F to 260 °F	(93 °C to 127 °C)
260 °F to 320 °F	(127 °C to 160 °C)

Downstream pressure ranges

For the following downstream pressures, three color-coded pilot valve springs are available:

Yellow	Blue	Red
3 to 30 psi (0.21 to 2.1 bar)	20 to 100 psi (1.4 to 6.9 bar)	80 to 190 psi (5.5 to 13.1 bar)

Pressure Shell Design Conditions

PMA	Maximum allowable pressure	Cast iron:	250 psi g @ 450 °F	(17 bar g @ 232 °C)
		Cast steel:	300 psi g @ 600 °F	(21 bar g @ 316 °C)
TMA	Maximum allowable temperature	Cast iron:	450 °F @ 250 psi g	(232 °C @ 17 bar g)
		Cast steel:	600 °F @ 300 psi g	(316 °C @ 21 bar g)

Capacities

The regulator is sized according to the temperature control requirements. For selection and sizing, see TI-P235-18-US and TI-P717-08-US

Materials

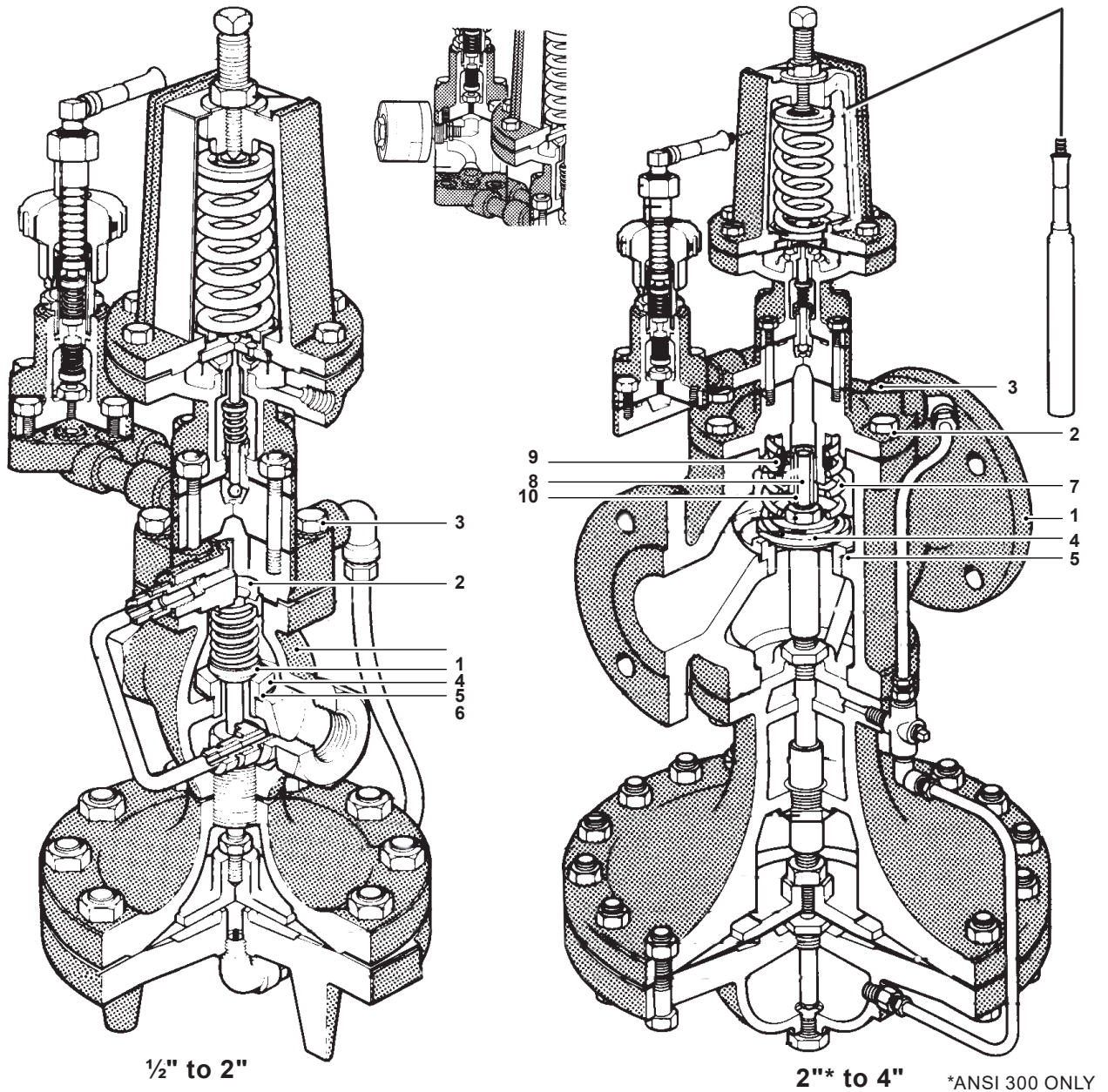

No.	Part	Material
1	Valve Body	Cast iron ASTM A 126 CL B
		Cast steel ASTM A216 Gr WCB
2	Cover	Cast iron ASTM A 126 CL B
		Cast steel ASTM A216 Gr WCB
3	Cover Bolts	Steel ASTM A449
4	Main Valve Head	Stainless steel
5	Main Valve Seat	Stainless steel
6	Main Valve Seat Gasket	Copper
7	Valve Return Spring	Stainless steel
8	Valve Stem	Stainless steel
9	Strainer Screen	Stainless steel
10	Valve Stem Sleeve	Stainless steel

Materials continued on next page

Materials (continued)

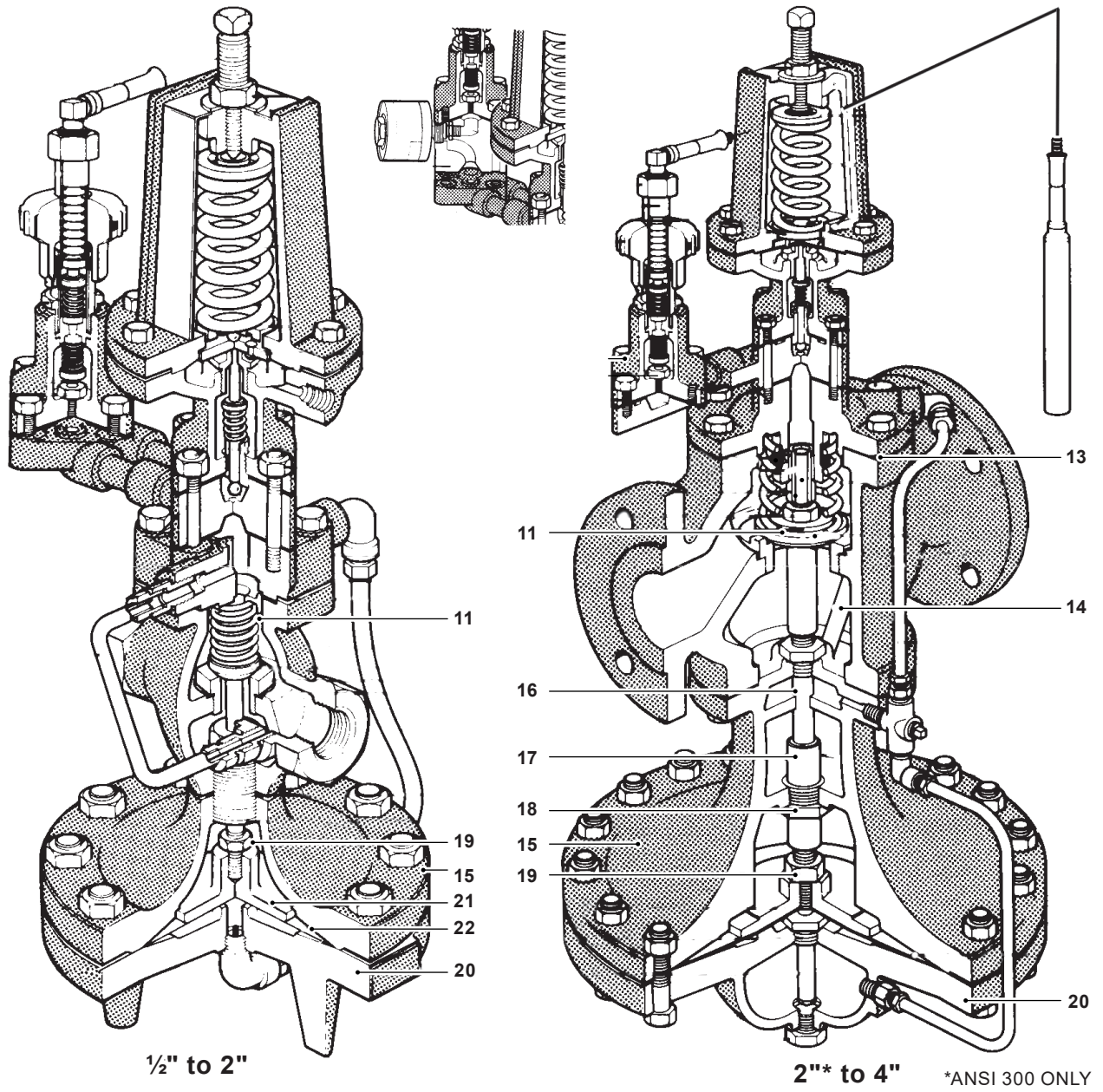

No.	Part	Material
11	Spring Guide	Cast iron 1/2"-2" (DN15 to DN50) CRS 2"* - 4" (DN50 to DN100)
12	Nut	Steel
13	Cover Gasket	Graphite
14	Pressure Equalizer Pipe	Stainless steel
15	Upper Diaphragm Case	Cast iron ASTM A 126 CL B Cast steel ASTM A216 Gr WCB
16	Stem Bushing	Stainless steel (2-1/2" - 4" (DN65 to DN100) Cast steel only)
17	Diaphragm Plate Stem	Stainless steel
18	Diaphragm Stem Guide	Stainless steel
19	Nut	Brass 1/2" - 2" (DN15 to DN50) Steel 2"* - 4" (DN50 to DN100)
20	Lower Diaphragm Case	Cast iron ASTM A 126 CL B Cast steel ASTM A216 Gr WCB

Materials continued on next page

Materials (continued)

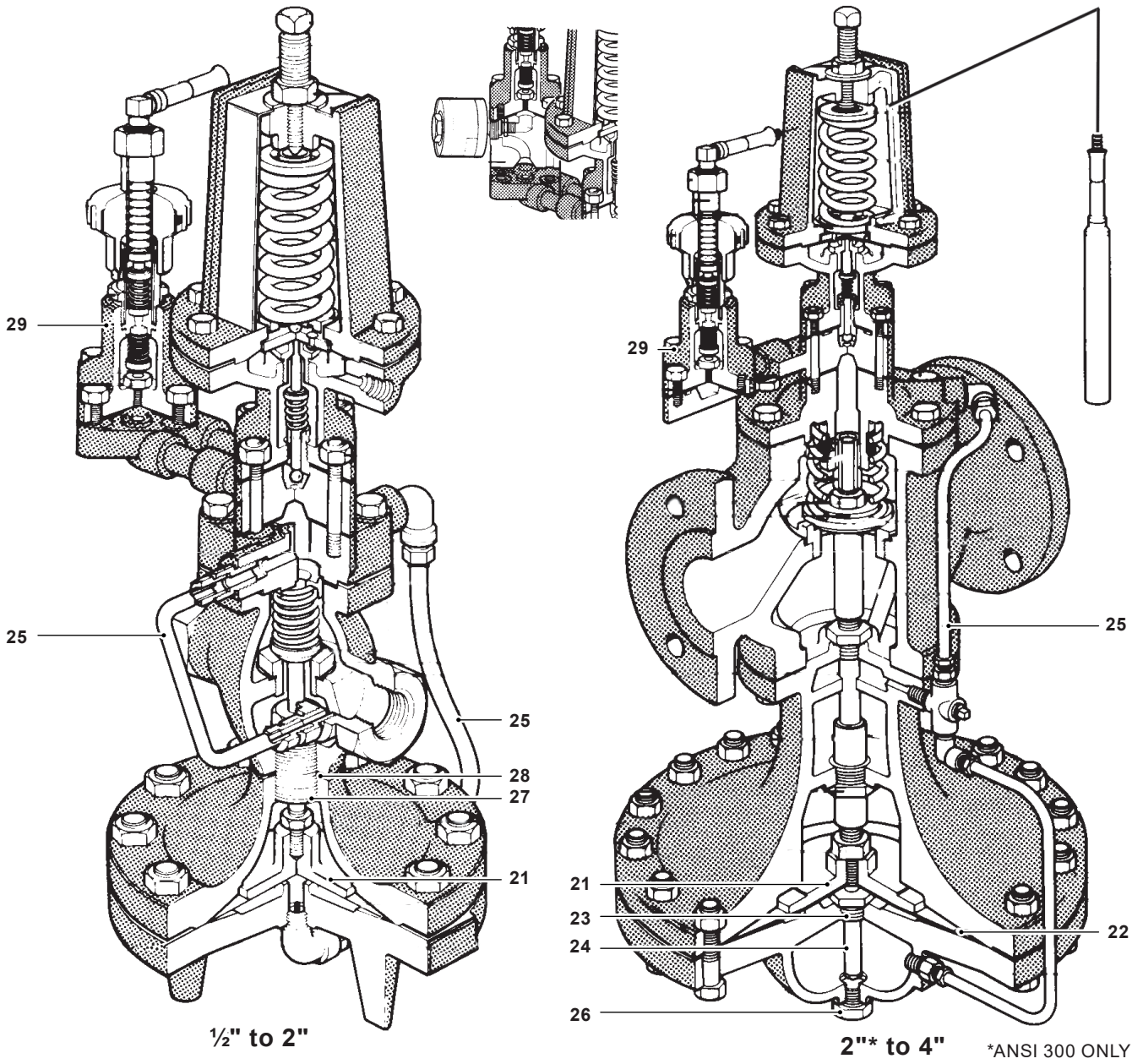

No.	Part	Material
21	Diaphragm Plate	Brass 1/2" - 2" (DN15 to DN50) C.I. 2" - 4" (DN50 to DN100)
22	Main Diaphragm (2 ply)	Stainless steel
23	Bushing	CRS
24	Tube & Orifice	Stainless steel
25	Tubing Assembly Cast Iron	Copper / Brass
	Tubing Assembly Cast Steel	Stainless Steel
26	Plug	(Cast iron) Brass
		(Cast steel) Steel
27	Connector Stud	Stainless steel
28	Body Gasket	1/2" - 2" (DN15 to DN50) Copper Clad
		2" - 4" (DN50 to DN100) Graphite
29	Pilot Valve Body	Cast iron
		Cast steel

ASTM A 126 CL B

Materials continued on next page

Materials (continued)

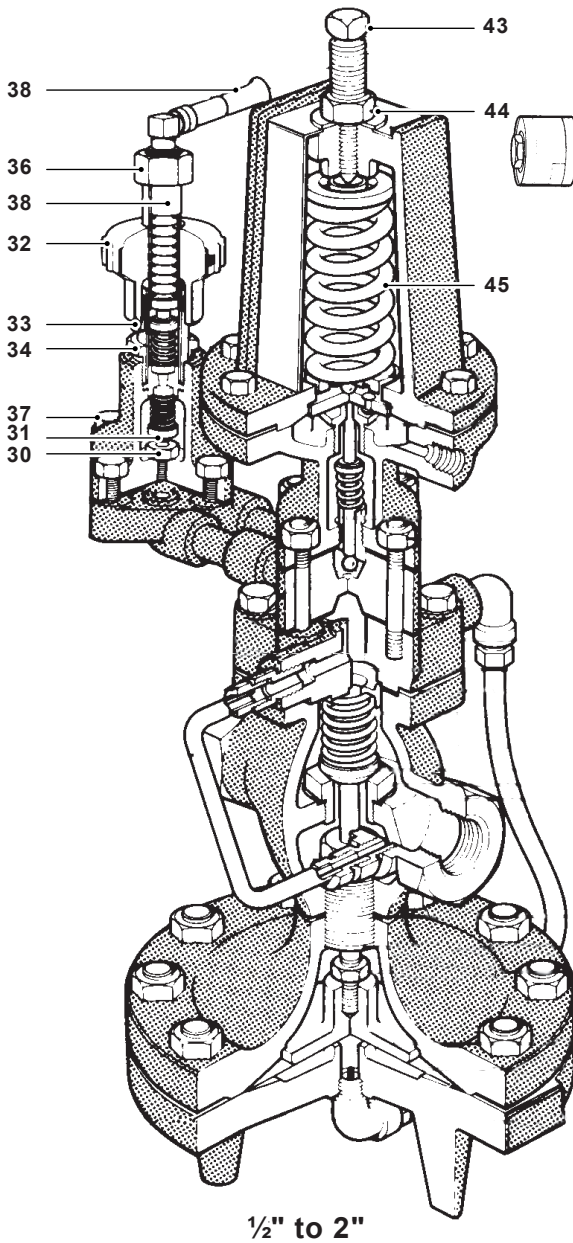

1/2" to 2"

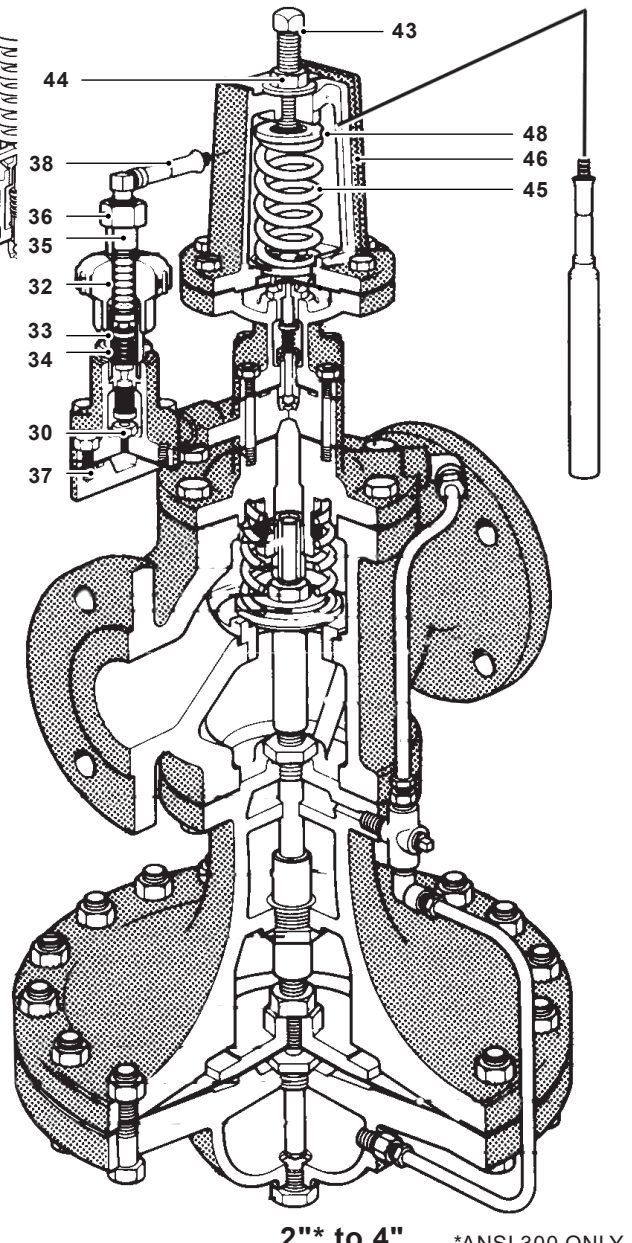

2" to 4" *ANSI 300 ONLY

No.	Part	Material
30	Pilot Valve Seat	Stainless steel
31	Pilot Valve Head	Stainless steel
32	Adjustment Knob	Phenolic
33	Pointer	Stainless steel
34	Extension Nut	Brass
35	Case Tube	Brass
36	Retaining Nut	Brass
37	Pilot Mounting Screws	Steel
38	Capillary Tube	Varies with style selected
39	Bulb	Varies with style selected
43	Adjustment Screw	Stainless steel
44	Jam Nut	Brass
45	Pilot Valve Spring	Steel

Materials continued on next page

Materials (continued)

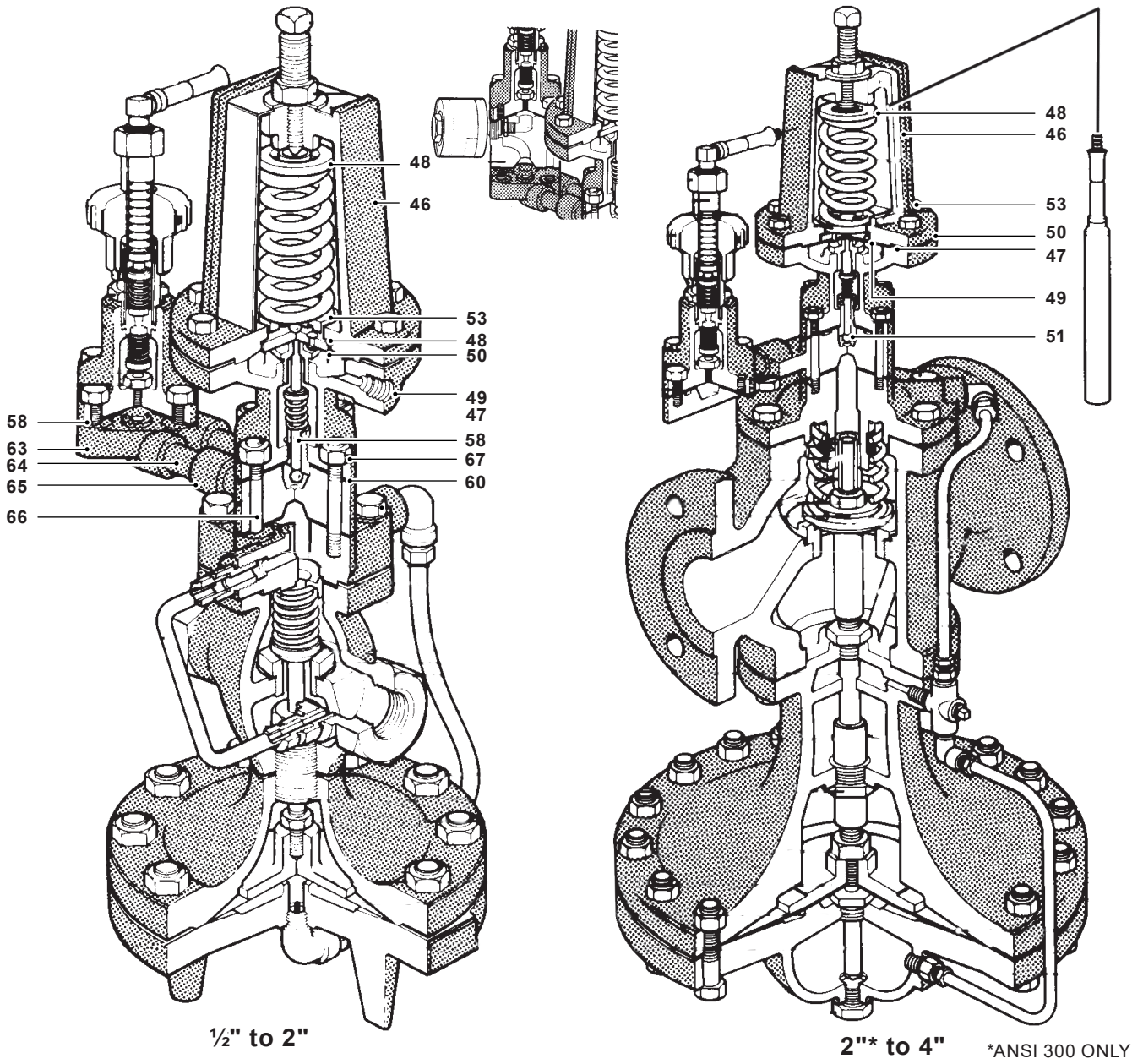

No.	Part	Material
46	Upper Diaphragm Case	Cast iron
		Cast steel
47	Lower Diaphragm Case	Cast iron
		Cast steel
48	Spring Plate	Steel ASTM A569
49	Diaphragm	Stainless steel
50	Diaphragm PLate	Brass
51	Pilot Head Spring	Stainless steel
52	Spring Retainer Cup	Stainless steel
53	Retaining Ring	Brass
54	Pilot Seat	Stainless steel
55	Pilot Head	Stainless steel
56	Head Stem	Stainless steel

Materials continued on next page

Materials (continued)

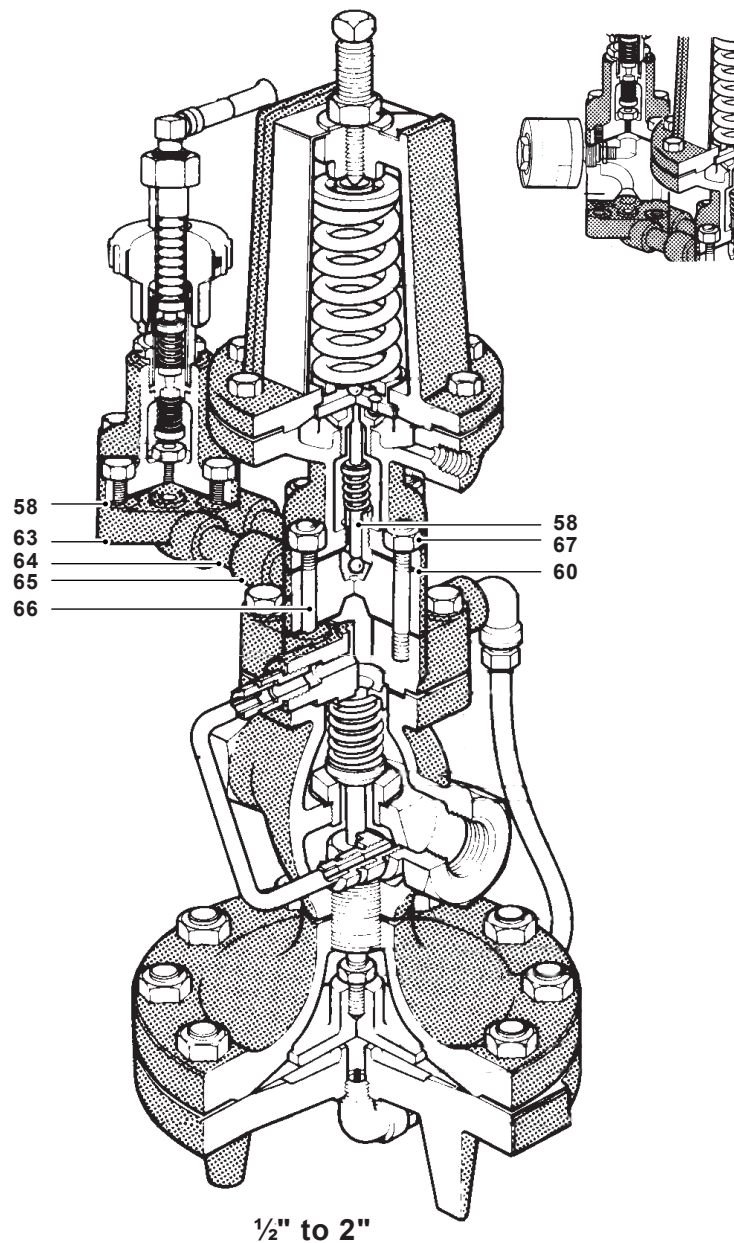

No.	Part	Material	
57	Stem Guide	Stainless steel	
58	Stem Guide Gasket	Stainless steel	
59	Seat Gasket	Stainless steel	
60	Pilot Gasket	Graphite	
61	Pilot Mounting Screws	Steel	ASTM A449
62	Diaphragm Case Screws	Steel	
63	"T" Pilot Adapter	Brass	
64	Adapter Pipe	Steel	
65	"P" Pilot Adapter	Ductile Iron	
		Cast steel	
66	Adapter Stud	Steel	
67	Adapter Nut	Steel	

Dimensions/weights (approximate) in inches (mm) and lbs (kg)

¼" NPT Sensing Line Connection

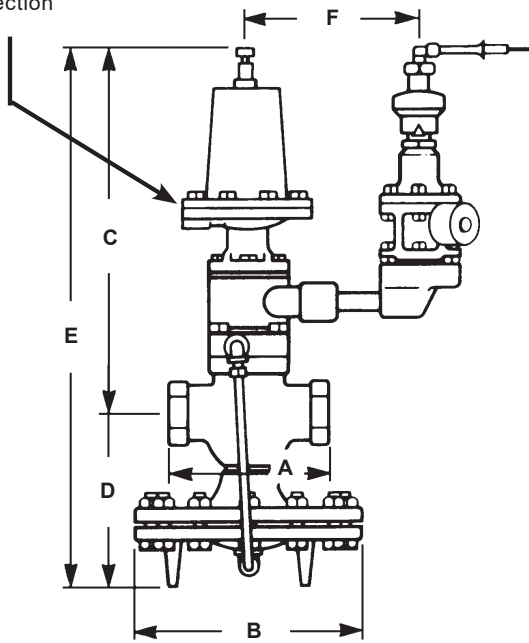

½" to 2"

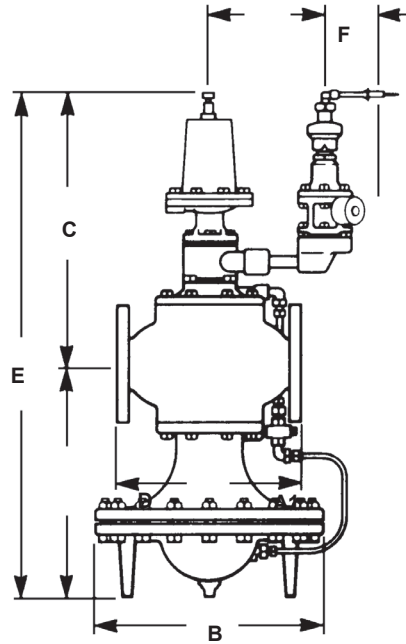

2"* to 4"

Size	A	ANSI 125 ANSI 150 A1	ANSI 250 ANSI 300 A1	B	C	D	E	F	Weight	
									Cast iron	Cast Steel
½", ¾"	5.5 (140)			7.6 (193)	13.25 (337)	6.2 (157)	19.4 (493)	5.0 (127)	41 lb (18.6 kg)	45 lb (20.4 kg)
1"	6.0 (152)			8.6 (218)	13.2 (335)	6.75 (171)	19.9 (505)	5.0 (127)	48 lb (21.8 kg)	52 lb (23.6kg)
1¼", 1½"	7.25 (184)			8.6 (218)	13.75 (349)	7.1 (180)	20.8 (528)	5.0 (127)	53.5 lb (24.3 kg)	60 lb (27.2kg)
2"	8.5 (216)		9.0 (229)	10.6 (269)	14.4 (366)	8.2 (208)	22.6 (574)	5.0 (127)	78 lb (35.4 kg)	85 lb (38.6 kg)
2½"		10.9 (277)	11.5 (292)	13.6 (346)	15.1 (384)	13.9 (353)	29.0 (737)	5.0 (127)	166 lb (75.3 kg)	181 lb (82.1 kg)
3"		11.75 (298)	12.5 (318)	13.6 (345)	15.0 (381)	14.4 (366)	29.4 (747)	5.0 (127)	197.5 lb (89.6 kg)	215 lb (97.5 kg)
4"		13.9 (353)	14.5 (368)	15.6 (396)	16.3 (414)	16.1 (409)	32.4 (823)	5.0 (127)	293.5 lb (133 kg)	320 lb (145 kg)

Sample specification

Pressure/Temperature Regulators shall be of the pilot-actuated, diaphragm-operated type with separate pressure and temperature pilots and electrical override. The main valve shall be single-seated, with hardened Stainless steel trim; the regulator body shall be Cast iron (Cast steel). The pilots shall be removable without disturbing the control connections. The temperature setting shall be adjustable without the use of tools, and the set point shall be indicated on a calibrated dial. The thermostatic system shall be solid fill, and shall incorporate overheat protection. The regulator shall be capable of dead-end shut-off. The electric pilot shall have a Enclosure: NEMA 2, 3, 3S, 4, & 4X enclosure with 120 VAC / 60 Hz coil.

Installation

The regulator should be installed in a horizontal line with suitable bypass and isolating valves. A steam trap should be installed upstream to prevent condensate from reaching the regulator. The trap and regulator should both be protected with a strainer. The thermostatic bulb must be carefully located in the medium being heated. The pressure sensing line may be located either in the downstream piping or in the steam space. Complete installation instructions are given in IM-3-017-US.

Maintenance

Complete installation and maintenance instructions are given in IM-3-017-US, a copy of which is supplied with each regulator. Available spare parts are shown on TI-P717-09-US and TI-P235-02-US.

Standard Transmission tubing for Cast Iron Valve will be Copper with Brass fittings.

Standard Transmission tubing for Cast Steel Valve will be Stainless Steel.

If a different material is required order the Spare Part Kit

Stainless Steel Transmission Tubing Kits

Item #	Size	Description
71464	½", ¾"	Kit, ½"-¾", 25 Valve, Stainless Steel, Transmission tubing
71465	1"	Kit, 1", 25 Valve, Stainless Steel, Transmission tubing
71466	1¼", 1½"	Kit, 1¼"-1½", 25 Valve, Stainless Steel, Transmission tubing
71467	2"	Kit, 2", 25 Valve, Stainless Steel, Transmission tubing
71468	2½"	Kit, 2½", 25 Valve, Stainless Steel, Transmission tubing
71469	3"	Kit, 3", 25 Valve, Stainless Steel, Transmission tubing
71470	4"	Kit, 4", 25 Valve, Stainless Steel, Transmission tubing

Copper Tubing Transmission Line Kits

Item #	Size	Description
57302	½", ¾"	Transmission tubing kit, ½"-¾", 25 Valve
57303	1"	Transmission tubing kit, 1", 25 Valve
57304	1¼", 1½"	Transmission tubing kit, 1¼"-1½", 25 Valve
57305	2"	Transmission tubing kit, 2", 25 Valve
58010	2½"	Transmission tubing kit, 2½", 25 Valve
58011	3"	Transmission tubing kit, 3", 25 Valve
58012	4"	Transmission tubing kit, 4", 25 Valve