



Pilot Operated Pressure Regulator with Electric Override 6" 25PE

Description

The 25PE has all of the features of the 25P, with the addition of an electric pilot. An electrical signal can override the pressure pilot. This valve meets Class IV shut-off specifications but is not suitable for dead-end service.

Model	25PE	
Sizes	6" (DN150)	
Connections	ANSI 125, 250	ANSI 150, 300
Construction	Cast Iron	Cast Steel
Options	Reduced Orifice Designated by "S"	
Electric pilot specifications	Enclosure: NEMA 4 & 7 (C&D) 115v (230v)/60Hz Inrush: 45 VA Normally closed 200 psi g (14 bar g) Max. operating pressure	
Electric pilot options	At pressures below 125 psi g (9 bar g), use the following electric pilot: Enclosure: NEMA 4 & 7 (C&D) 115v (230v)/60Hz Inrush: 45 VA Normally closed 140 psi g (10 bar g) Max Operating Pressure	

Typical applications

Steam pressure reducing applications where the PRV must also respond to an electrical program timer, safety or limit switch, or remote manual switch.

Downstream pressure ranges

For the following downstream pressures, three color-coded pilot valve springs are available:

Yellow:	Blue:	Red:
3 to 30 psi (0.2 to 2 bar)	20 to 100 psi (1.4 to 6.9 bar)	80 to 250 psi (5.5 to 17.2 bar)

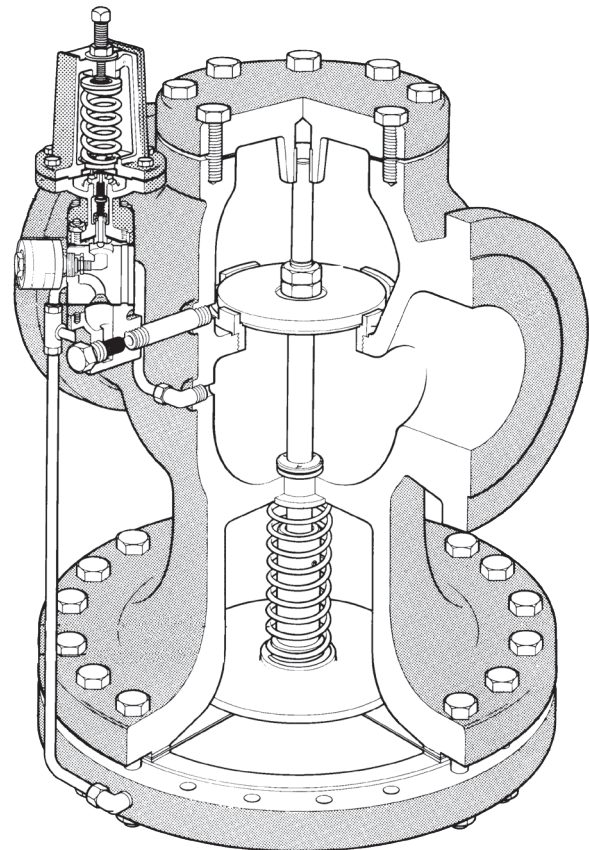

Materials

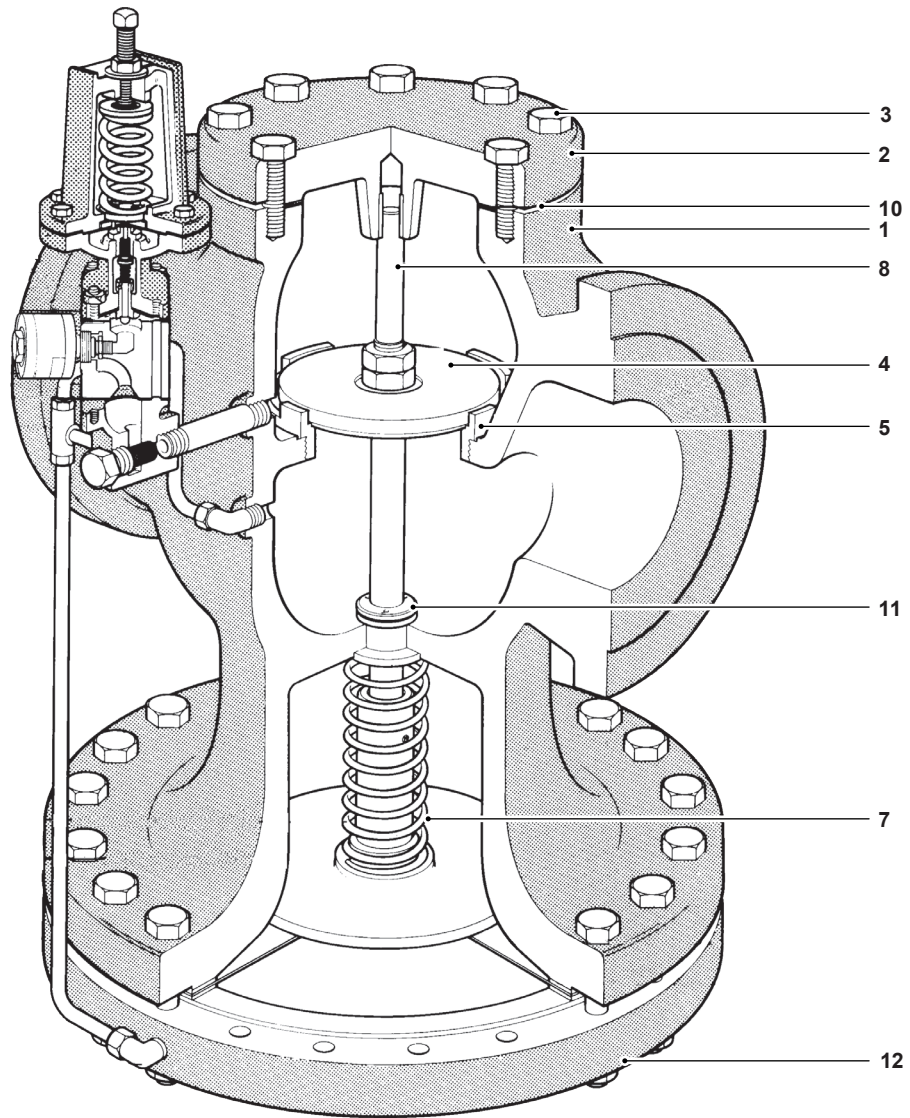

No.	Part	Material	
1	Valve Body	Cast Iron	ASTM A 126 CL B
		Cast Steel	ASTM A 216 WC B
2	Cover	Cast Iron	ASTM A 126 CL B
		Cast Steel	ASTM A 216 WC B
3	Cover Bolts	Steel	AISI 1038
4	Main Valve Head	Stainless Steel	ASTM A 743 CA 40
5	Main Valve Seat	Stainless Steel	ASTM A 743 CA 40
7	Valve Return Spring	Stainless Steel	AISI 302
8	Valve Stem	Stainless Steel	AISI 304
10	Cover Gasket	Graphite	BS 2815A
11	Stem Bushing	Brass	ASTM B16
12	Lower Diaphragm Case	Cast Iron	ASTM A 126 CL B
		Cast Steel	ASTM A 216 WC B

Materials continued on next page

Materials (continued)

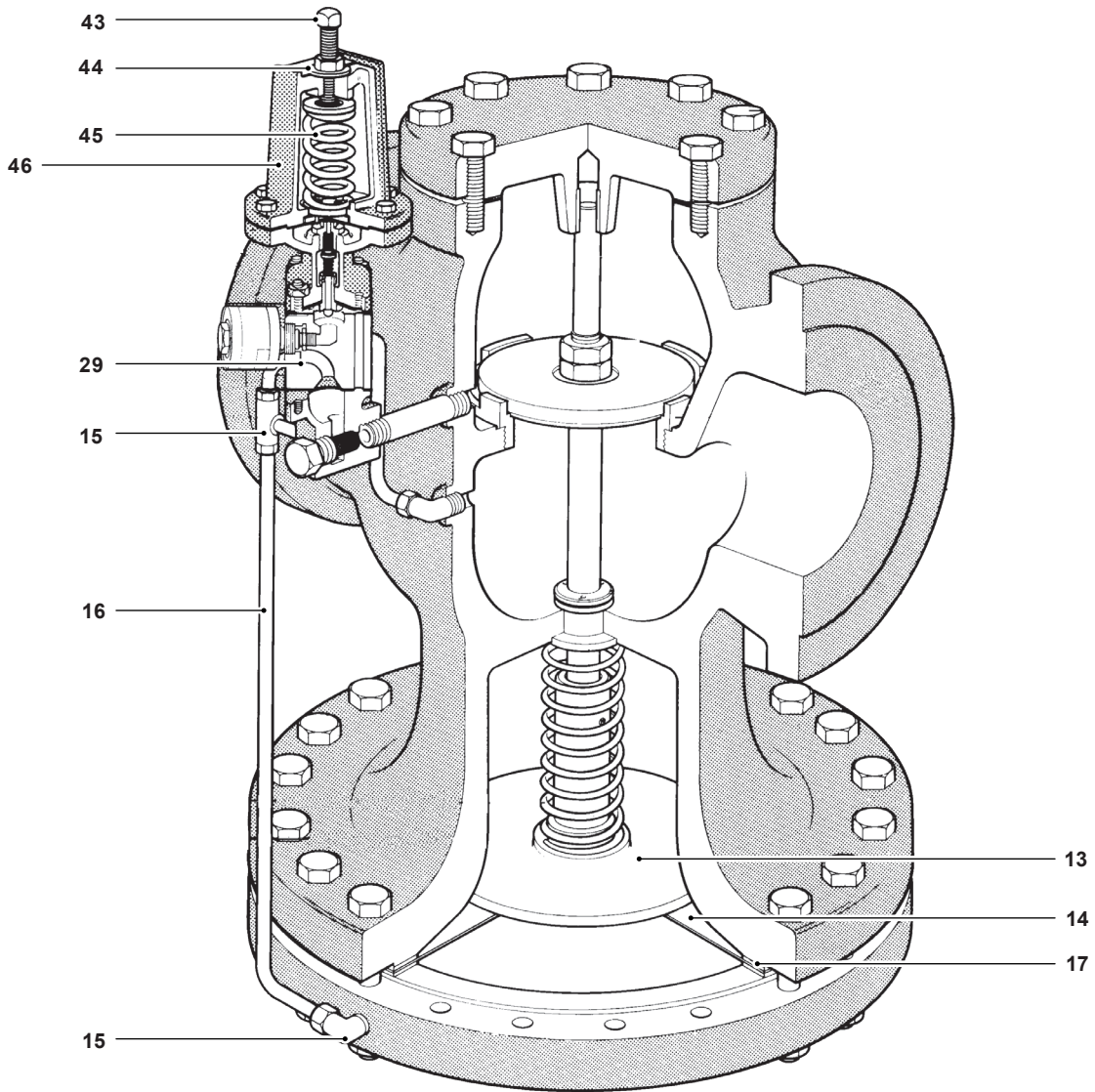

No.	Part	Material	
13	Diaphragm Plate	Stainless Steel	ASTM A 743 CA 40
14	Main Diaphragm (2 ply)	Stainless Steel	ASTM A240
15	Tube & Orifice	Brass	ASTM B16
16	Tubing Assembly	Copper	ASTM B280 (122)
17	Diaphragm Gasket (2)	Graphite	BS 2815A
29	Electric Pilot Adapter	Cast Iron	ASTM A 126 CL B
43	Adjustment Screw	Stainless Steel	AISI 304
44	Jam Nut	Brass	ASTM B6
45	Pilot Valve Spring	Steel	AISI 1060
46	Upper Diaphragm Case	Cast Iron	ASTM A 126 CL B
		Cast Steel	ASTM A 216 WC B

Materials continued on next page

Materials (continued)

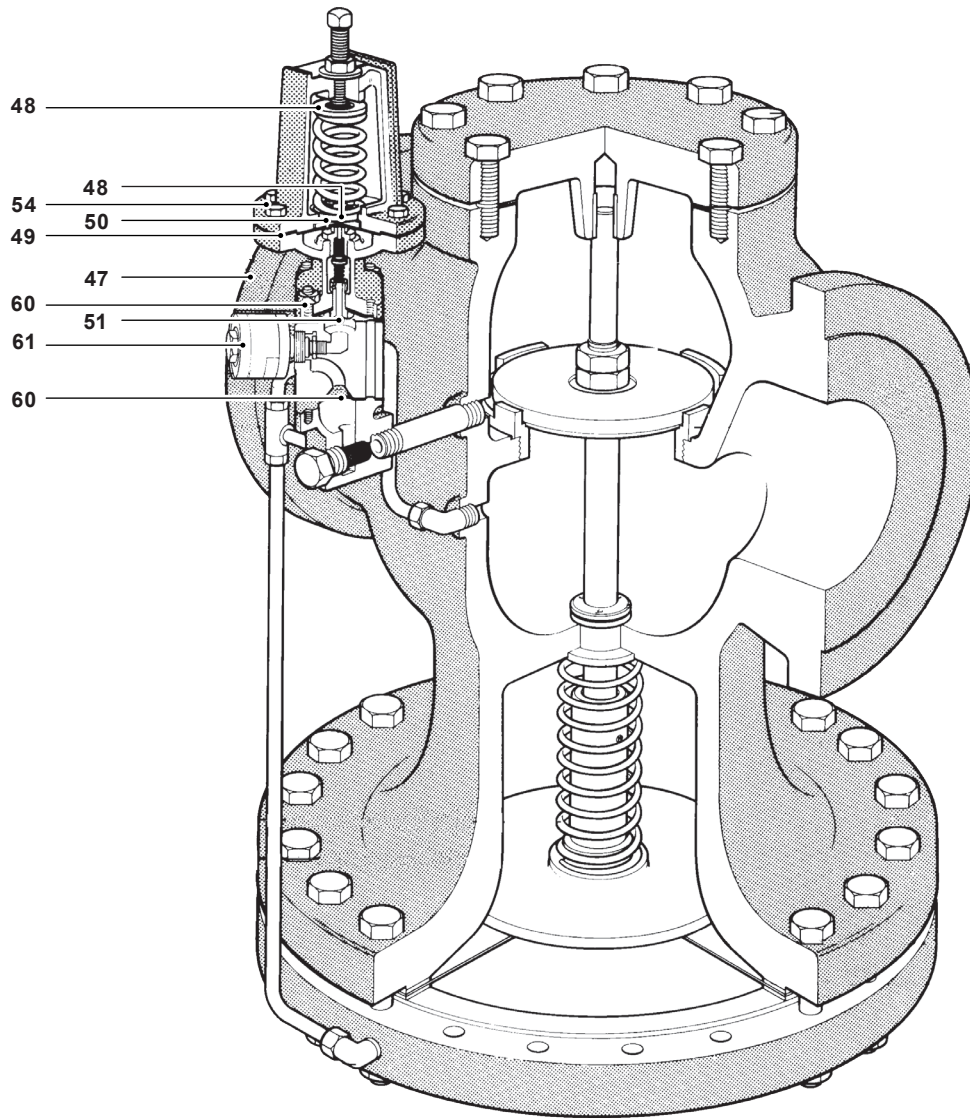

No.	Part	Material	
47	Lower Diaphragm Case	Cast Iron	ASTM A 126 CL B
		Cast Steel	ASTM A 216 WC B
48	Spring Plate	Steel	ASTM A569
49	Diaphragm	Stainless Steel	ASTM A240
50	Diaphragm Plate	Brass	ASTM B36
51	Head & Seat Assembly	Stainless Steel	AISI 440
		Stainless Steel	AISI 440F
54	Diaphragm Case Screws	Steel 5/16" - 18 x 1"	ASTM A449
60	Pilot Gasket	Graphite	
61	Electric Solenoid Valve		

Limiting operating conditions

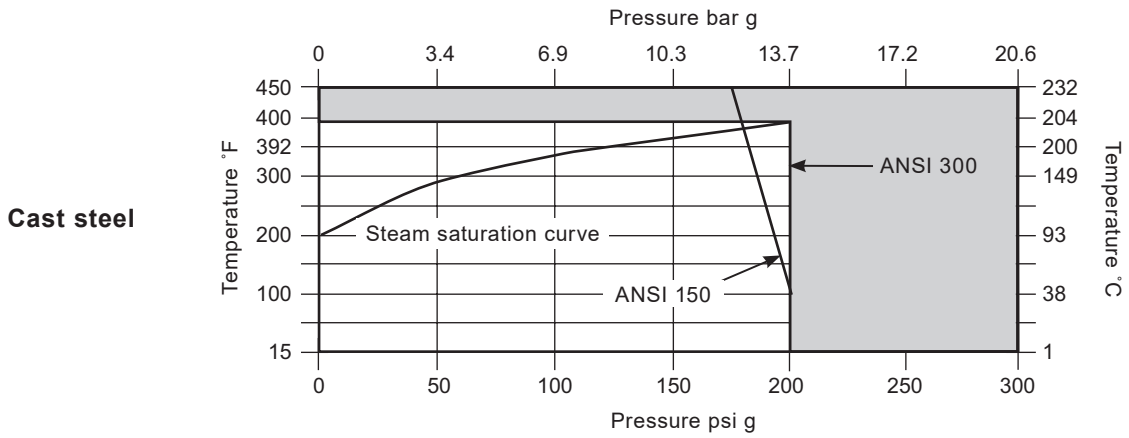
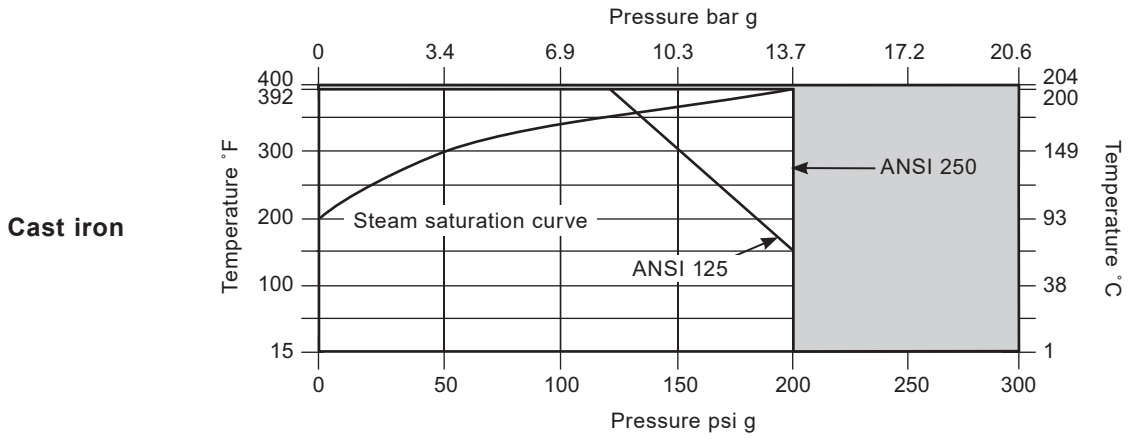

 The product should not be used in shaded area.

Dimensions/weights (approximate) in inches (millimeters) and lbs (kg)

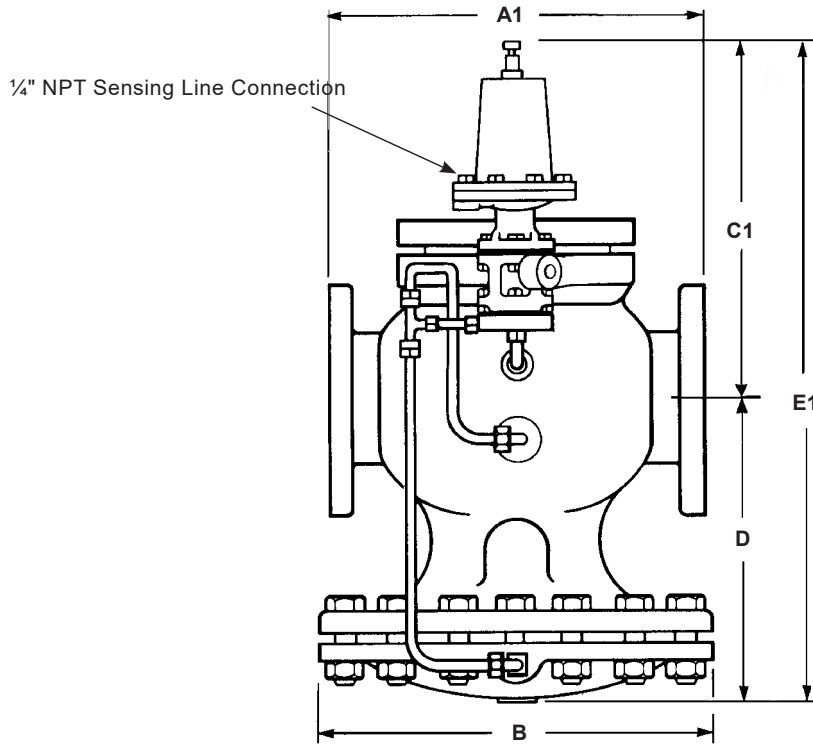

	ANSI 125/150		ANSI 250/300				
Size	A1	A1	B	C1	D	E1	Weight
6"	18.1 (460)	18.9 (480)	19.75 (502)	17.2 (437)	17.1 (434)	34.3 (872)	595 lb (270 kg)

Cv Values

Size	6"	6" "S"
Cv value	280	156

Sample specifications

The pressure regulator shall be of the pilot-actuated diaphragm operated type. The main valve shall be single-seated with hardened stainless steel trim; the valve body shall be cast iron. The pilot shall be externally mounted to the regulator body. The electric pilot shall have a NEMA 4 & 7 (C & D) enclosure with 115v (230v) 60 Hz coil.

Capacities

For selection & sizing data, see TI-P717-08-US.

Installation

The valve should be installed in a horizontal line with suitable bypass and isolating valves. A steam trap should be installed upstream to prevent condensate from reaching the valve. The trap and regulator should both be protected with a strainer separator set. The pressure sensing line should be located in a straight section of the downstream piping at least 10 pipe diameters from the nearest fitting. Complete installation instructions are given in IM-3-000-US.

Maintenance

Complete installation and maintenance instructions are given in IM-3-000-US and ADVP 3029, a copy of which is supplied with each regulator. Available spare parts are shown on TI-P335-11-US and TI-P235-02-US.