



# Pilot Operated Pressure Regulator

## 1/2" to 4" 25P

### Description

The 25P is a self-actuated pilot-operated pressure regulator. Downstream pressure is fed back through an external sensing line to the pressure pilot, which adjusts the opening of the main valve so as to maintain the set pressure. The main valve can close tight for ANSI/FCI 70-2 Class IV shut off when steam is not required.

Model	25P			
Sizes	1/2" to 2"	2 1/2", 3", 4"	1/2" to 2"	2", 2 1/2", 3", 4"
Connections	NPT	ANSI 125 flanged	NPT	ANSI 300 flanged
Construction	Cast iron		Cast steel	
Options		ANSI 250 flanged		ANSI 150 flanged (excludes 2")
Transmission Tubing	Copper Tubing		Stainless Steel Tubing	

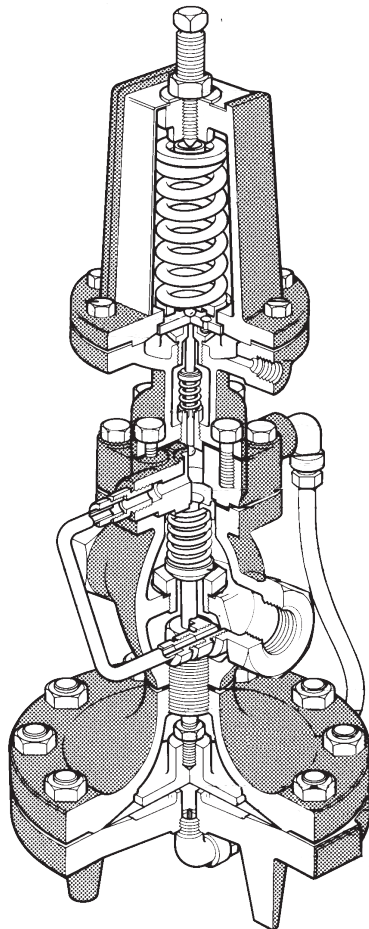

1/2" to 2"

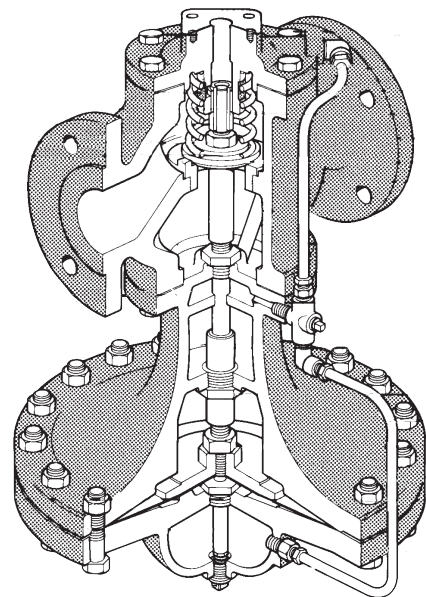

2" (ANSI 300 only) to 4"

## Typical applications

The 25P is a reliable, accurate regulator to reduce steam from a high supply pressure to the most efficient operating pressure of the equipment, and to protect the equipment from dangerously high pressures.

## Downstream pressure ranges

For the following downstream pressures, three color-coded pilot valve springs are available:

Yellow: 3 to 30 psi (0.21 to 2.1 bar)

Blue: 20 to 100 psi (1.4 to 6.9 bar)

Red: 80 to 250 psi (5.5 to 17.2 bar)

## Capacities

For selection and sizing data, see TI-P717-08-US.

## Pressure/temperature limits

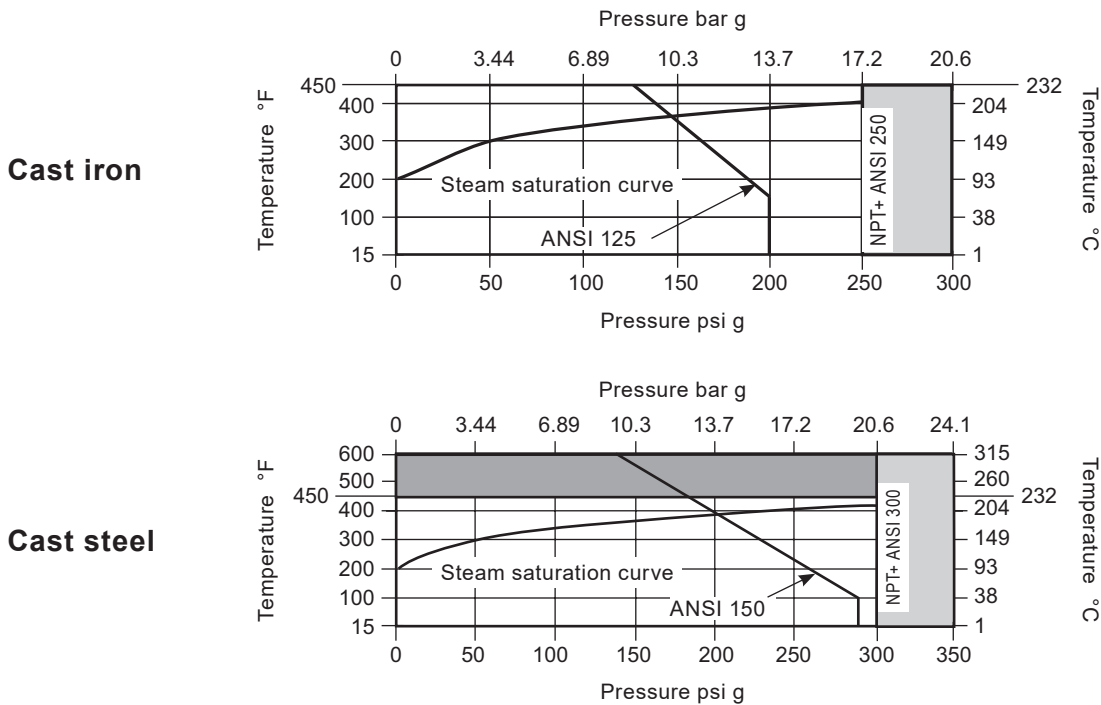

- The product should not be used in shaded area.
- For operation in this region, stainless steel transmission tubing need be fitted.  
**Note:** Maximum temperature for Stainless steel tubing is 600 °F (316 °C)

## Sample specification

The pressure regulator shall be of the pilot-actuated diaphragm operated type. The main valve shall be single-seated with hardened stainless steel trim; the regulator body shall be cast iron (cast steel). The pilot shall be bolted directly to the regulator body. The regulator shall be capable of dead-end shut-off.

## Installation

The regulator should be installed in a horizontal line with suitable bypass and isolating valves. A steam trap should be installed upstream to prevent condensate from reaching the regulator. The trap and regulator should both be protected with a strainer. The pressure sensing line should be located in a straight section of the downstream piping at least 10 pipe diameters from the nearest fitting. Complete installation instructions are given in IM-P717-06-US.

## Maintenance

Complete installation and maintenance instructions are given in IM-P717-06-US, a copy of which is supplied with each regulator. Available spare parts are shown on TI-P717-09-US and TI-P235-02-US.

## Materials

1/2" to 2"

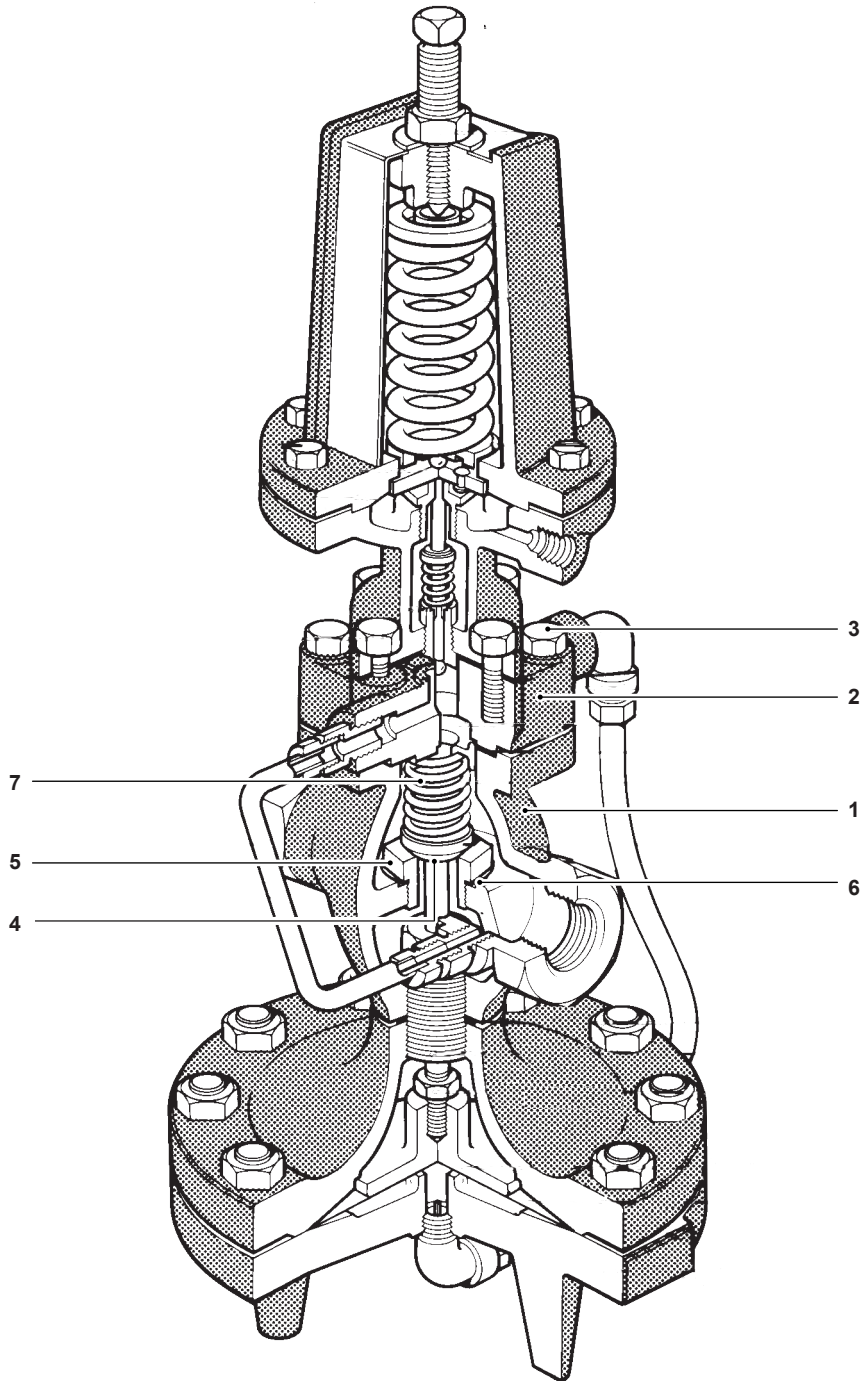

No.	Part	Material	
1	Valve Body	Cast iron	ASTM A 126 CL B
		Cast steel	ASTM A216 Gr WCB
2	Cover	Cast iron	ASTM A 126 CL B
		Cast steel	ASTM A216 Gr WCB
3	Cover Bolts	Steel	ASTM A449
4	Main Valve Head	Stainless steel	
5	Main Valve Seat	Stainless steel	
6	Main Valve Seat Gasket	Copper	
7	Valve Return Spring	Stainless steel	

Materials continued on next page

**Materials (continued)**

**1/2" to 2"**

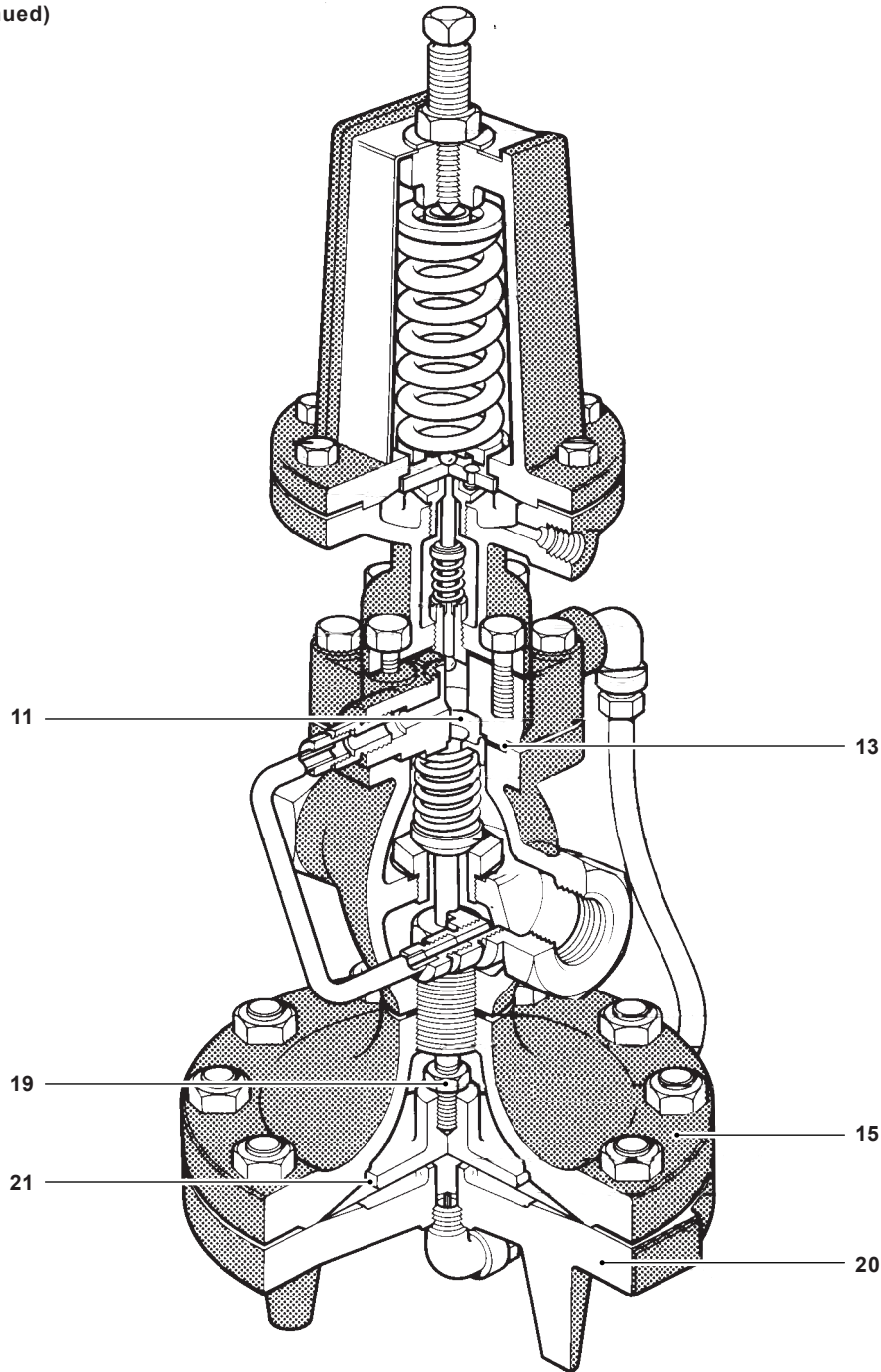

No.	Part	Material
11	Spring Guide	Cast iron 1/2"-2" CRS 2"* - 4"
13	Cover Gasket	Graphite
15	Upper Diaphragm Case	Cast iron Cast steel
		ASTM A 126 CL B ASTM A216 Gr WCB
19	Nut	Brass 1/2" - 2" Steel 2"* - 4"
20	Lower Diaphragm Case	Cast iron Cast steel
		ASTM A 126 CL B ASTM A216 Gr WCB
21	Diaphragm Plate	Stainless steel 1/2" - 2" C.I. 2"* - 4"

Materials continued on next page

**Materials (continued)**

**1/2" to 2"**

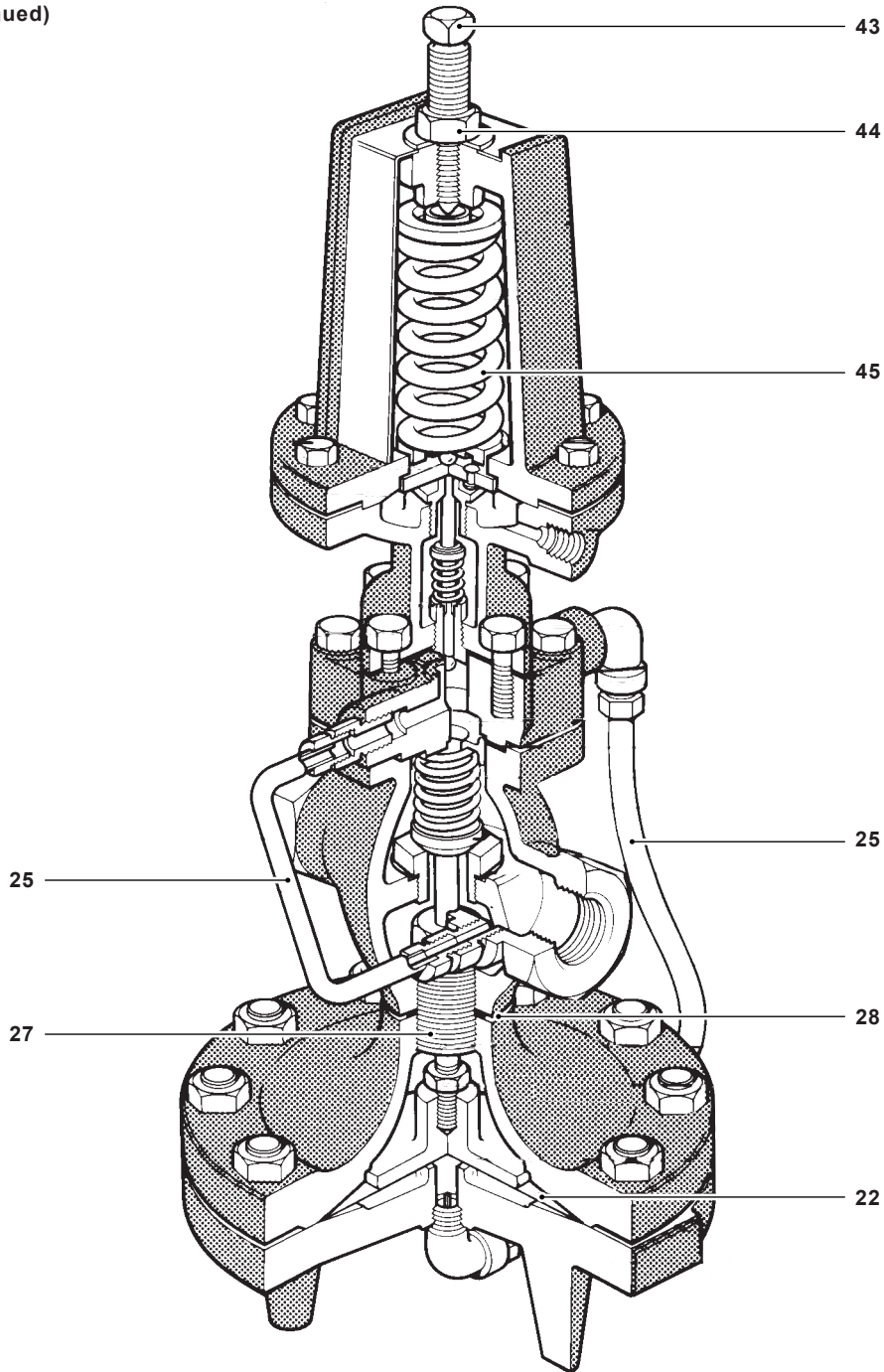

No.	Part	Material
22	Main Diaphragm (2 ply)	Stainless steel
25	Tubing Assembly Cast Iron	Copper / Brass
	Tubing Assembly Cast Steel	Stainless Steel
27	Connector Stud	Stainless steel
28	Body Gasket	1/2" - 2" Copper Clad
		2"* - 4" Graphite
43	Adjustment screw	Stainless steel
44	Jam Nut	Brass
45	Pilot Valve Spring	Steel

Materials continued on next page

**Materials (continued)**

1/2" to 2"

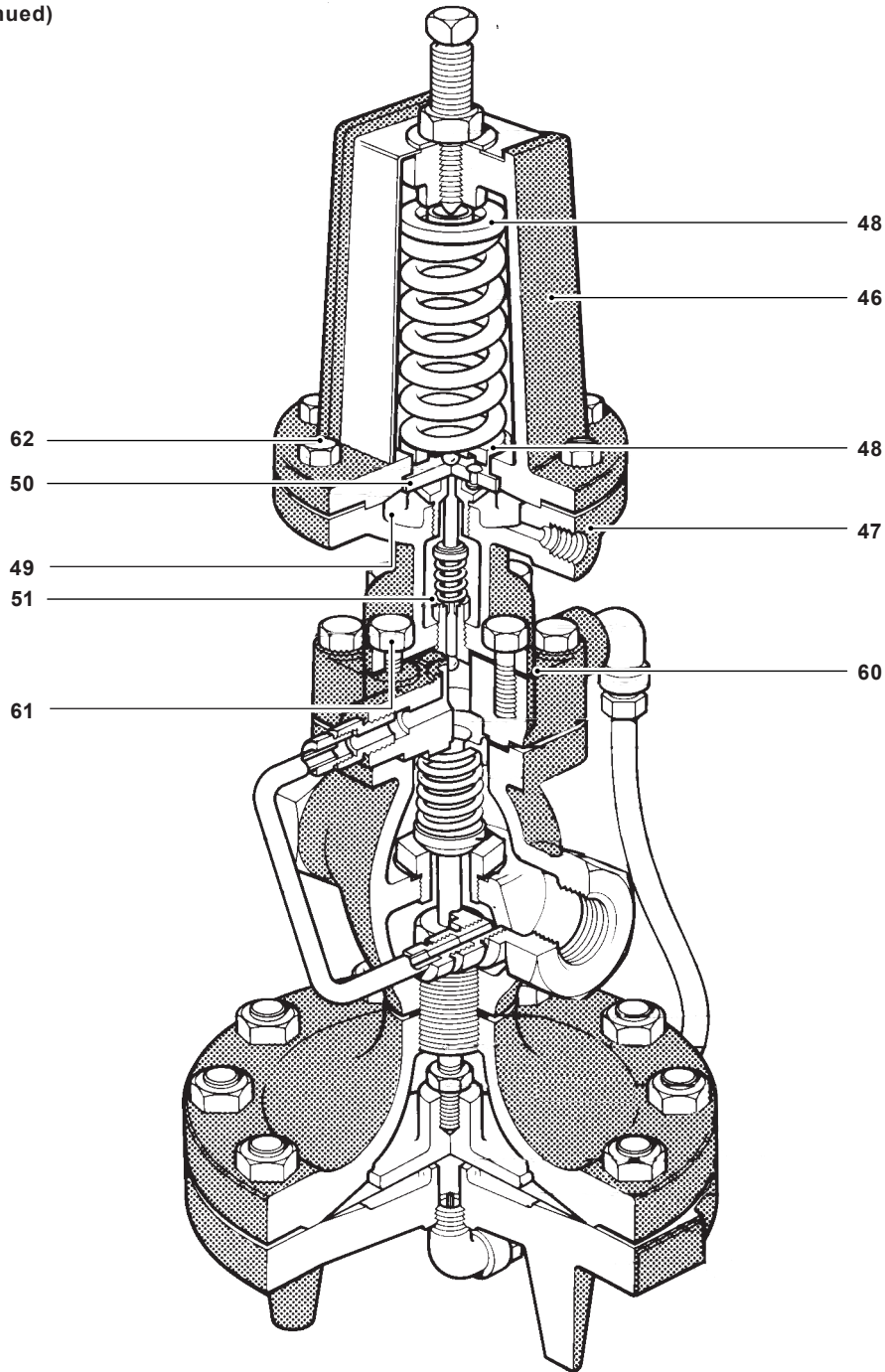

No.	Part	Material	
46	Upper Diaphragm Case	Cast iron	ASTM A 126 CL B
		Cast steel	ASTM A216 Gr WCB
47	Lower Diaphragm Case	Cast iron	ASTM A 126 CL B
		Cast steel	ASTM A216 Gr WCB
48	Spring Plate	Steel	
49	Diaphragm (2 ply)	Stainless steel	
51	Pilot Head Spring	Stainless steel	
60	Pilot Gasket	Graphite	
61	Pilot Mounting Screws	Steel	
62	Diaphragm Case Screws	Steel	ASTM A449

## Materials

2" (ANSI 300 only) to 4"

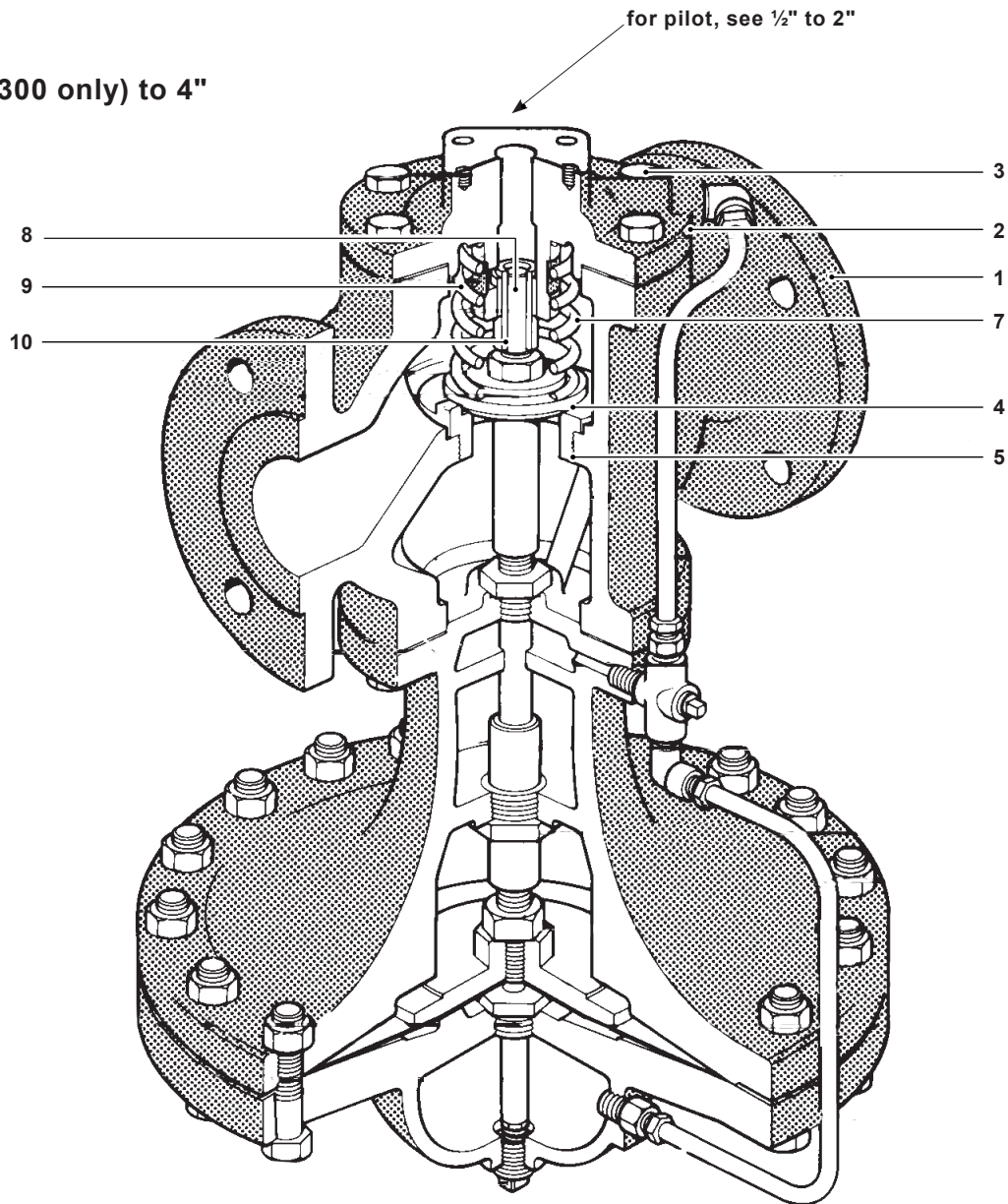

No.	Part	Material	
1	Valve Body	Cast iron	ASTM A 126 CL B
		Cast steel	ASTM A216 Gr WCB
2	Cover	Cast iron	ASTM A 126 CL B
		Cast steel	ASTM A216 Gr WCB
3	Cover Bolts	Steel	ASTM A449
4	Main Valve Head	Stainless steel	
5	Main Valve Seat	Stainless steel	
7	Valve Return Spring	Stainless steel	
8	Valve Stem	Stainless steel	
9	Strainer Screen	Stainless steel	
10	Valve Stem Sleeve	Stainless steel	

Materials continued on next page

**Materials (continued)**

**2" (ANSI 300 only) to 4"**

for pilot, see 1/2" to 2"

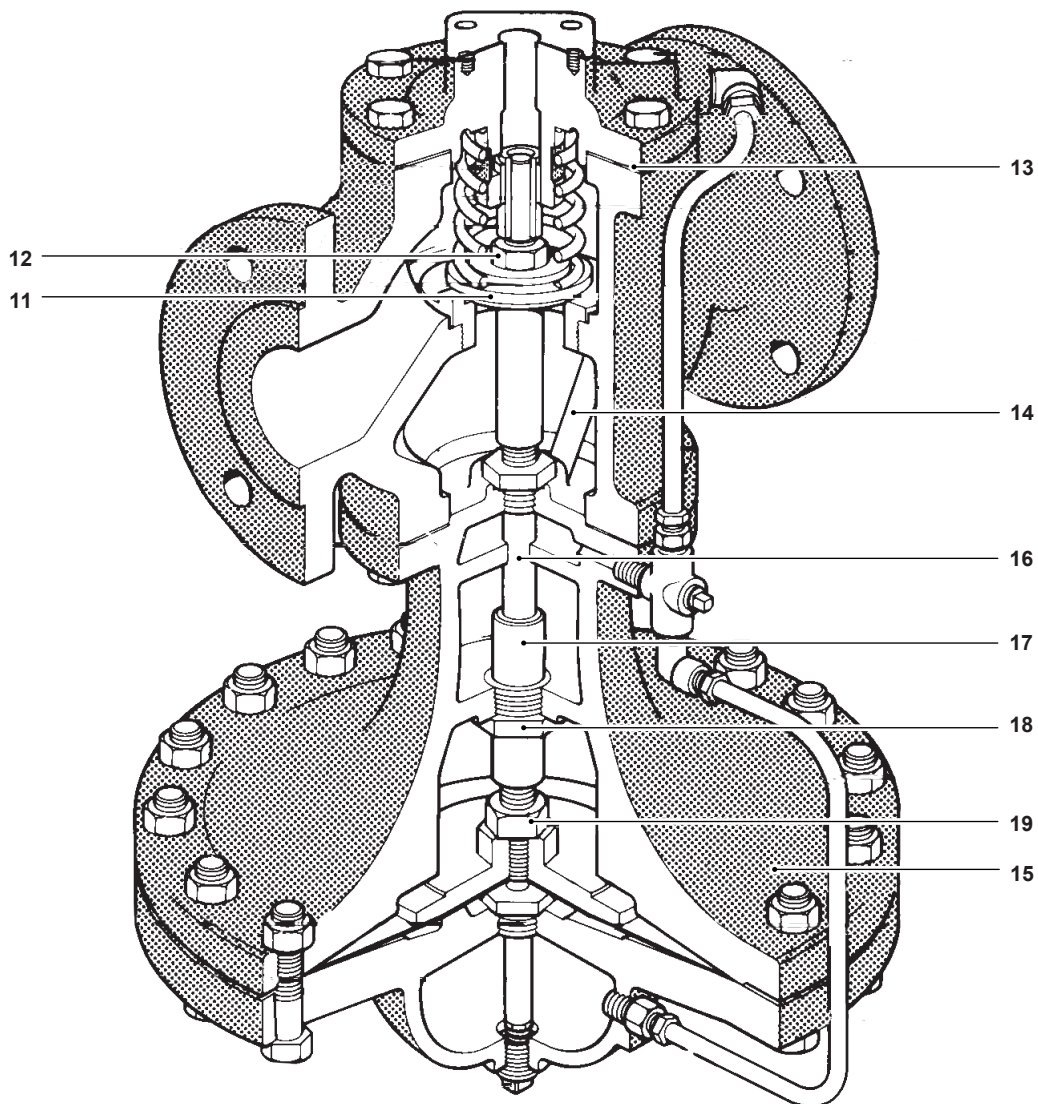

No.	Part	Material
11	Spring Guide	Cast iron 1/2"-2" CRS 2"* - 4"
12	Nut	Steel
13	Cover Gasket	Graphite
14	Pressure Equalizer Pipe	Stainless steel
15	Upper Diaphragm Case	Cast iron ASTM A 126 CL B Cast steel ASTM A216 Gr WCB
16	Stem Bushing	Stainless steel (2 1/2" - 4" Cast steel only)
17	Diaphragm Plate Stem	Stainless steel
18	Diaphragm Stem Guide	Stainless steel
19	Nut	Brass 1/2" - 2" Steel 2"* - 4"

Materials continued on next page

**Materials (continued)**

**2" (ANSI 300 only) to 4"**

for pilot, see 1/2" to 2"

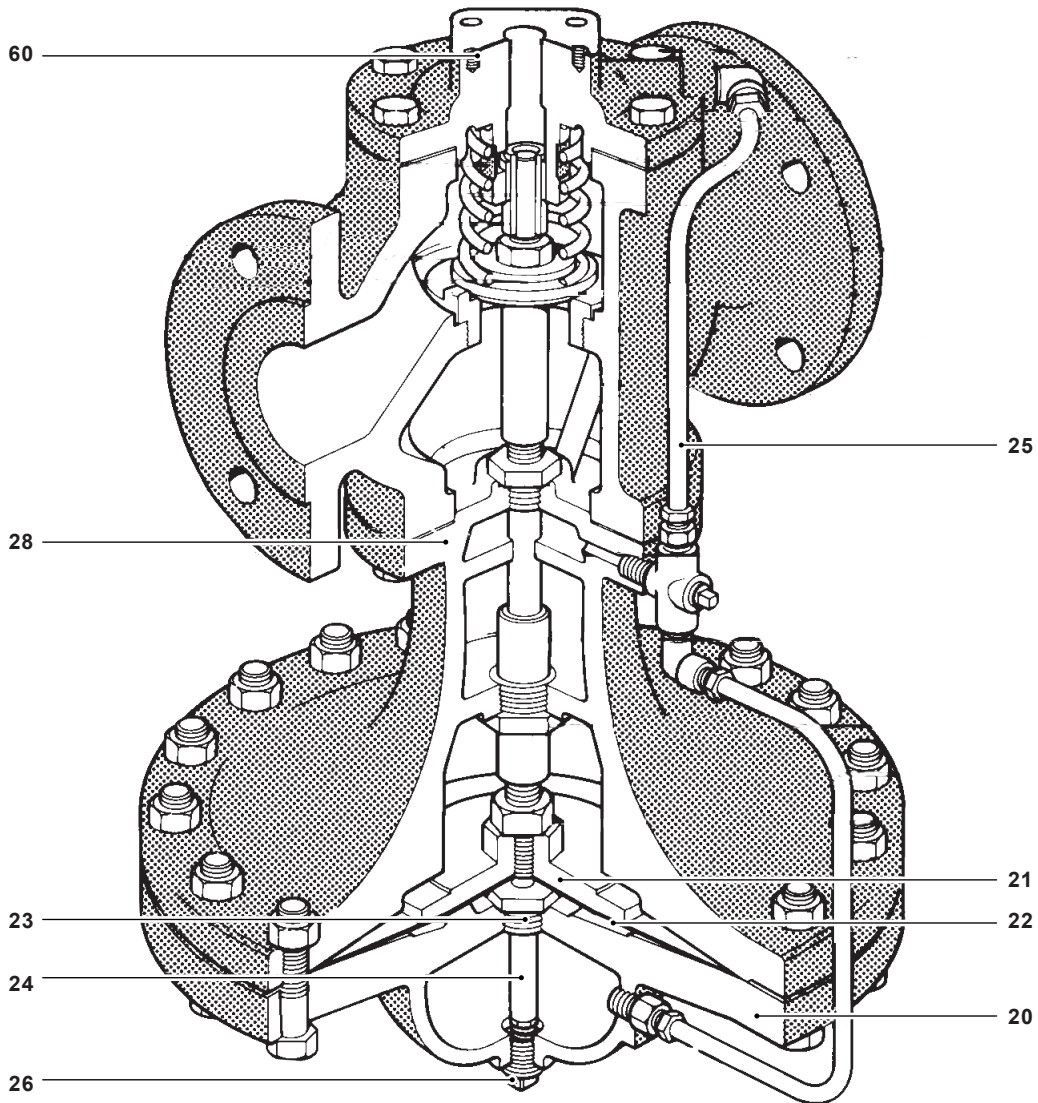

No.	Part	Material
20	Lower Diaphragm Case	Cast iron
		Cast steel
		ASTM A 126 CL B
		ASTM A216 Gr WCB
21	Diaphragm Plate	Stainless steel 1/2" - 2" C.I. 2"* - 4"
22	Main Diaphragm (2 ply)	Stainless steel
23	Bushing	CRS
24	Tube and Orifice	Stainless steel
25	Tubing Assembly Cast Iron	Copper / Brass
	Tubing Assembly Cast Steel	Stainless Steel
26	Plug	(Cast iron)
		(Cast steel)
		Brass
		Steel
28	Body Gasket	1/2" - 2" Copper Clad 2"* - 4" Graphite
60	Pilot Gasket	Graphite

**Dimensions/weights (approximate) in mm (inches) and kg (lbs)**

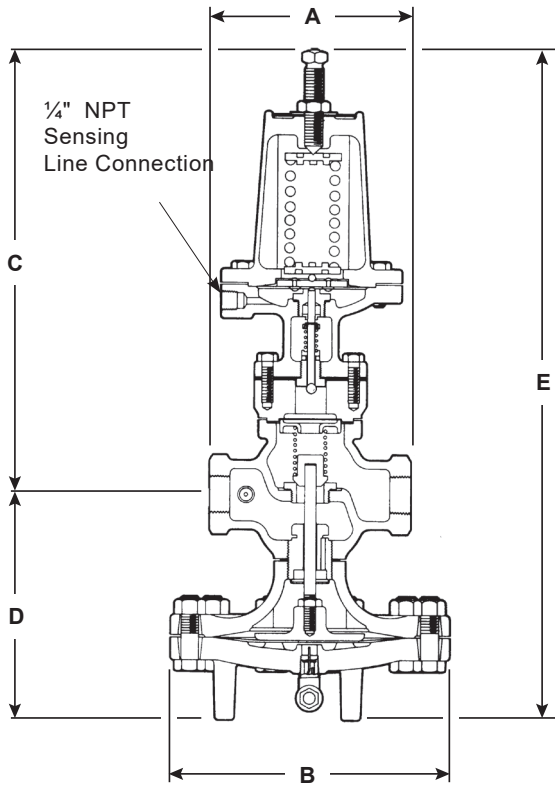

**1/2" to 2"**

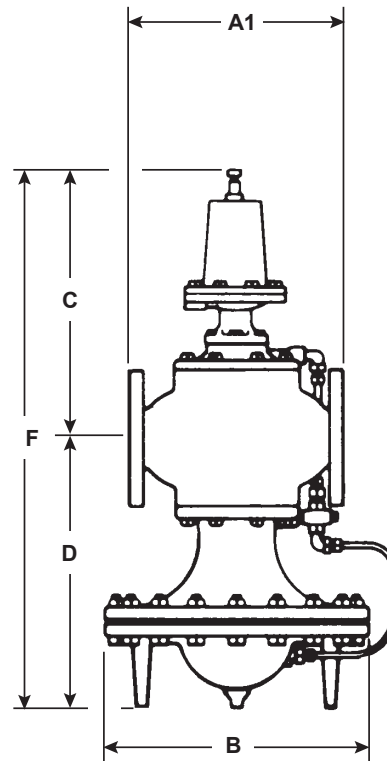

**2" (ANSI 300 only) to 4"**

Size	A	ANSI 125 ANSI 150 A1	ANSI 250 ANSI 300 A1	B	C	D	E	Weight	
								Cast Iron	Cast Steel
1/2", 3/4"	5.5 (140)			7.6 (193)	12.2 (310)	6.2 (157)	18.4 (467)	32 (14.5)	35 (15.9)
1"	6.0 (152)			8.6 (218)	12.1 (307)	6.75 (171)	18.9 (480)	39 (17.7)	43 (19.5)
1 1/4", 1 1/2"	7.25 (184)			8.6 (218)	12.7 (323)	7.1 (80)	19.75 (502)	44 (20)	48 (21.8)
2"	8.5 (216)		9.0 (229)	10.6 (269)	13.3 (338)	8.2 (208)	21.5 (546)	69 (31.3)	75 (34)
2 1/2"		10.9 (277)	11.5 (292)	13.6 (345)	14.0 (356)	13.9 (353)	27.9 (709)	157 (71.2)	171 (77.6)
3"		11.75 (298)	12.5 (318)	13.6 (345)	13.9 (353)	14.4 (366)	28.4 (721)	188 (85.3)	205 (93)
4"		13.9 (353)	14.5 (368)	15.6 (396)	15.25 (387)	16.1 (409)	31.4 (798)	284 (129)	309 (140)

Standard Transmission tubing for Cast Iron Valve will be Copper with Brass fittings.

Standard Transmission tubing for Cast Steel Valve will be Stainless Steel.

If a different material is required order the Spare Part Kit

### Stainless Steel Transmission Tubing Kits

Item #	Size	Description
71464	½", ¾"	Kit, ½"-¾", 25 Valve, Stainless Steel, Transmission tubing
71465	1"	Kit, 1", 25 Valve, Stainless Steel, Transmission tubing
71466	1¼", 1½"	Kit, 1¼"-1½", 25 Valve, Stainless Steel, Transmission tubing
71467	2"	Kit, 2", 25 Valve, Stainless Steel, Transmission tubing
71468	2½"	Kit, 2½", 25 Valve, Stainless Steel, Transmission tubing
71469	3"	Kit, 3", 25 Valve, Stainless Steel, Transmission tubing
71470	4"	Kit, 4", 25 Valve, Stainless Steel, Transmission tubing

### Copper Tubing Transmission Line Kits

Item #	Size	Description
57302	½", ¾"	Transmission tubing kit, ½"-¾", 25 Valve
57303	1"	Transmission tubing kit, 1", 25 Valve
57304	1¼", 1½"	Transmission tubing kit, 1¼"-1½", 25 Valve
57305	2"	Transmission tubing kit, 2", 25 Valve
58010	2½"	Transmission tubing kit, 2½", 25 Valve
58011	3"	Transmission tubing kit, 3", 25 Valve
58012	4"	Transmission tubing kit, 4", 25 Valve