



# Pilot Operated Back Pressure Regulator

## 1/2" to 4" 25BP

### Description

The 25BP Back Pressure Regulator maintains a constant upstream pressure in a piping system. The reverse-acting pressure pilot opens the main valve when the sensed upstream pressure increases.

The 25BP is NOT a safety valve, and should NEVER be used as such.

Model	25BP			
Sizes	1/2" to 2" (DN15 to DN50)	2 1/2", 3", 4" (DN65, DN80, DN100)	1/2" to 2" (DN15 to DN50)	2", 2 1/2", 3", 4" (DN50, DN65, DN80, DN100)
Connections	NPT	ANSI 125	NPT	ANSI 300
Construction	Cast iron		Cast steel	
Options		ANSI 250		ANSI 150 (excludes 2")
Transmission Tubing	Copper Tubing		Stainless Steel Tubing	

1/2" to 2"

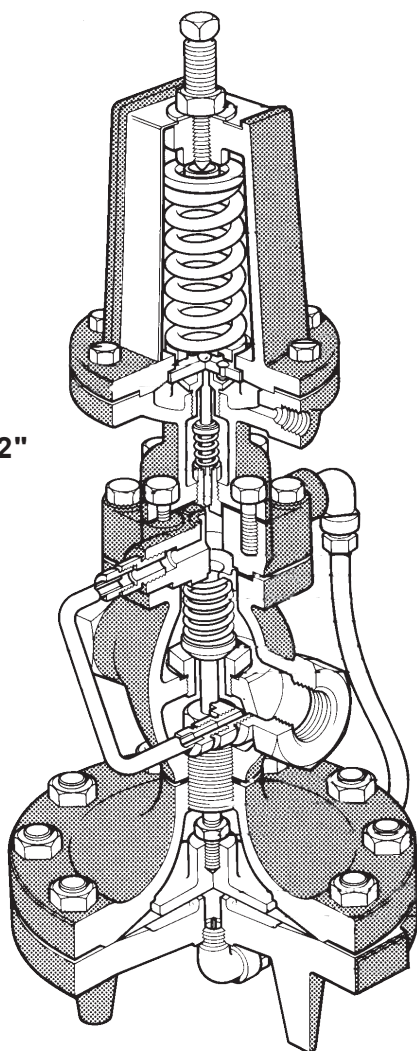

2" to 4"

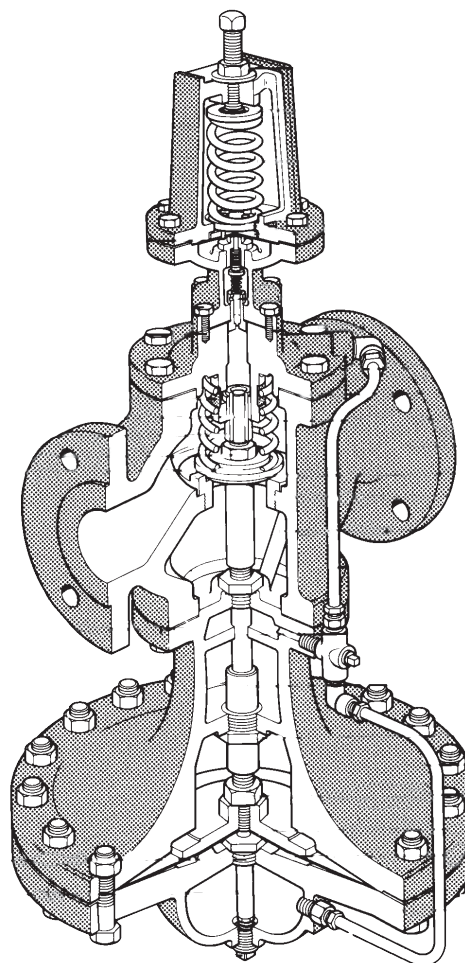

## Typical applications

The modulated release of surplus steam ensures that the set maximum pressure in the steam space or upstream piping will not be exceeded. Flash steam recovery systems to release excess flash steam limits the flash tank pressure. For elimination of non-critical loads, see TI-P717-07-US.

## Limiting operating conditions

	NPT:	250 psi g (17 bar g) @ 450 °F (232 °C)
	ANSI 125:	125 psi g ( 8 bar g) @ 450 °F (232 °C)
PMO	Maximum operating pressure	ANSI 250: 250 psi g (17 bar g) @ 450 °F (232 °C)
		ANSI 150: 185 psi g (12 bar g) @ 450 °F (232 °C)
		ANSI 300: 300 psi g (20 bar g) @ 450 °F (232 °C)
	Maximum temperating temperature	450 °F (232 °C)

## Upstream pressure ranges

For the following upstream pressures, three color-coded pilot valve springs are available:

Yellow	Blue	Red
3 to 30 psi (0.2 to 2 bar)	20 to 100 psi (1.3 to 6.9 bar)	80 to 250 psi (5.5 to 17.2 bar)

## Pressure shell design conditions

PMA	Maximum allowable pressure	Cast iron:	250 psi g/0-450 °F (17 bar g/0-232 °C)
		Cast steel:	300 psi g/0-600 °F (21 bar g/0-316 °C)
TMA	Maximum allowable temperature	Cast iron:	450 °F/0-250 psi g (232 °C/0-17 bar g)
		Cast steel:	600 °F/0-300 psi g (316 °C/0-21 bar g)

## Materials

1/2" to 2"

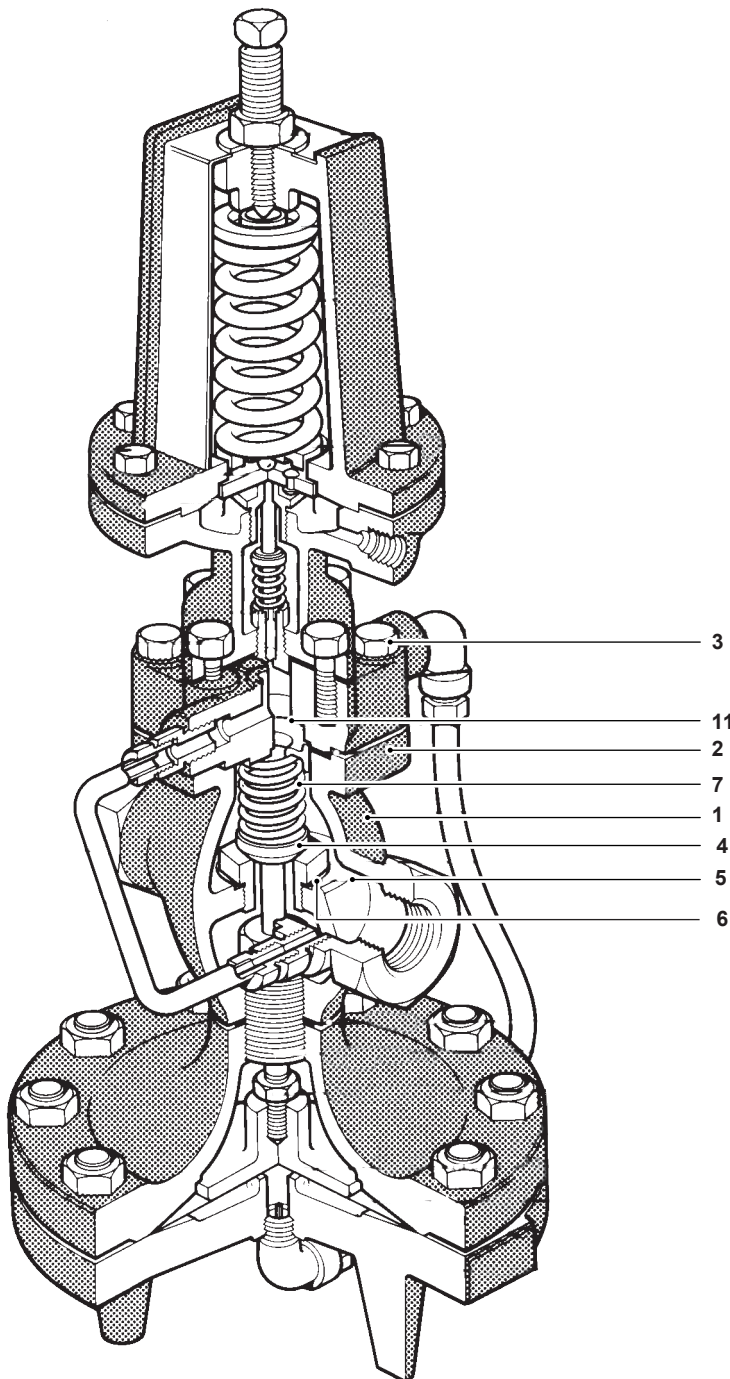

No.	Part	Material
1	Valve Body	Cast iron ASTM A 126 CL B
		Cast steel ASTM A216 Gr WCB
2	Cover	Cast iron ASTM A 126 CL B
		Cast steel ASTM A216 Gr WCB
3	Cover Bolts	Steel ASTM A449
4	Main Valve Head	Stainless steel 400 Series Stn Stl
5	Main Valve Seat	Stainless steel
6	Main Valve Seat Gasket	Copper
7	Valve Return Spring	Stainless steel
11	Spring Guide	Cast iron 1/2"-2" (DN15 to DN50) CRS 2** - 4" (DN50 to DN100)

Materials continued on next page

**Materials** (continued)

1/2" to 2"

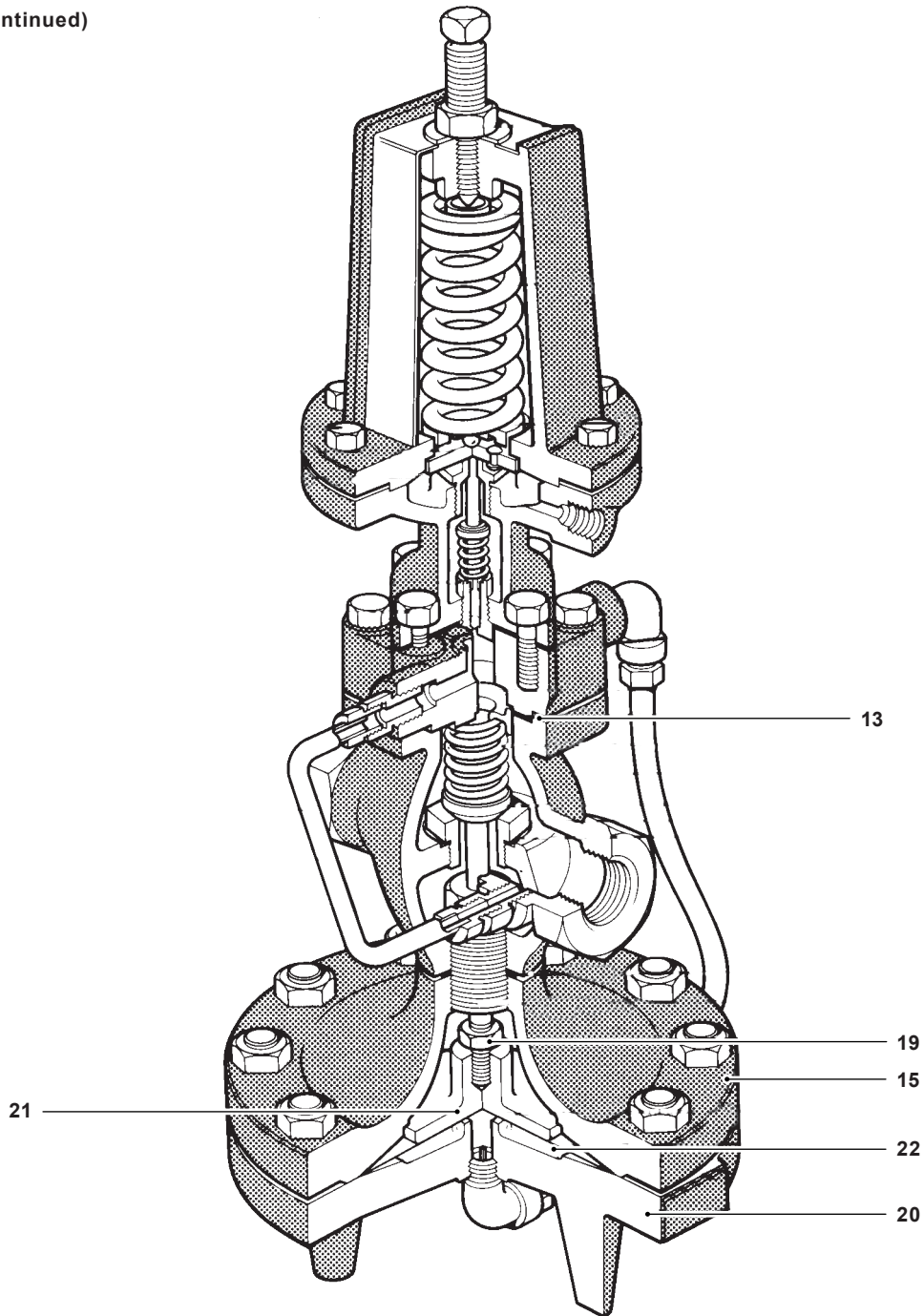

No.	Part	Material
13	Cover Gasket	Graphite
15	Upper Diaphragm Case	Cast iron <span style="float: right;">ASTM A 126 CL B</span>
		Cast steel <span style="float: right;">ASTM A216 Gr WCB</span>
19	Nut	Brass 1/2" - 2" (DN15 to DN50)
		Steel 2"* - 4" (DN50 to DN100)
20	Lower Diaphragm Case	Cast iron <span style="float: right;">ASTM A 126 CL B</span>
		Cast steel <span style="float: right;">ASTM A216 Gr WCB</span>
21	Diaphragm Plate	Brass 1/2" - 2" (DN15 to DN50)
		C.I. 2"* - 4" (DN50 to DN100)
22	Main Diaphragm (2 ply)	Stainless steel

**Materials continued on next page**

**Materials (continued)**

1/2" to 2"

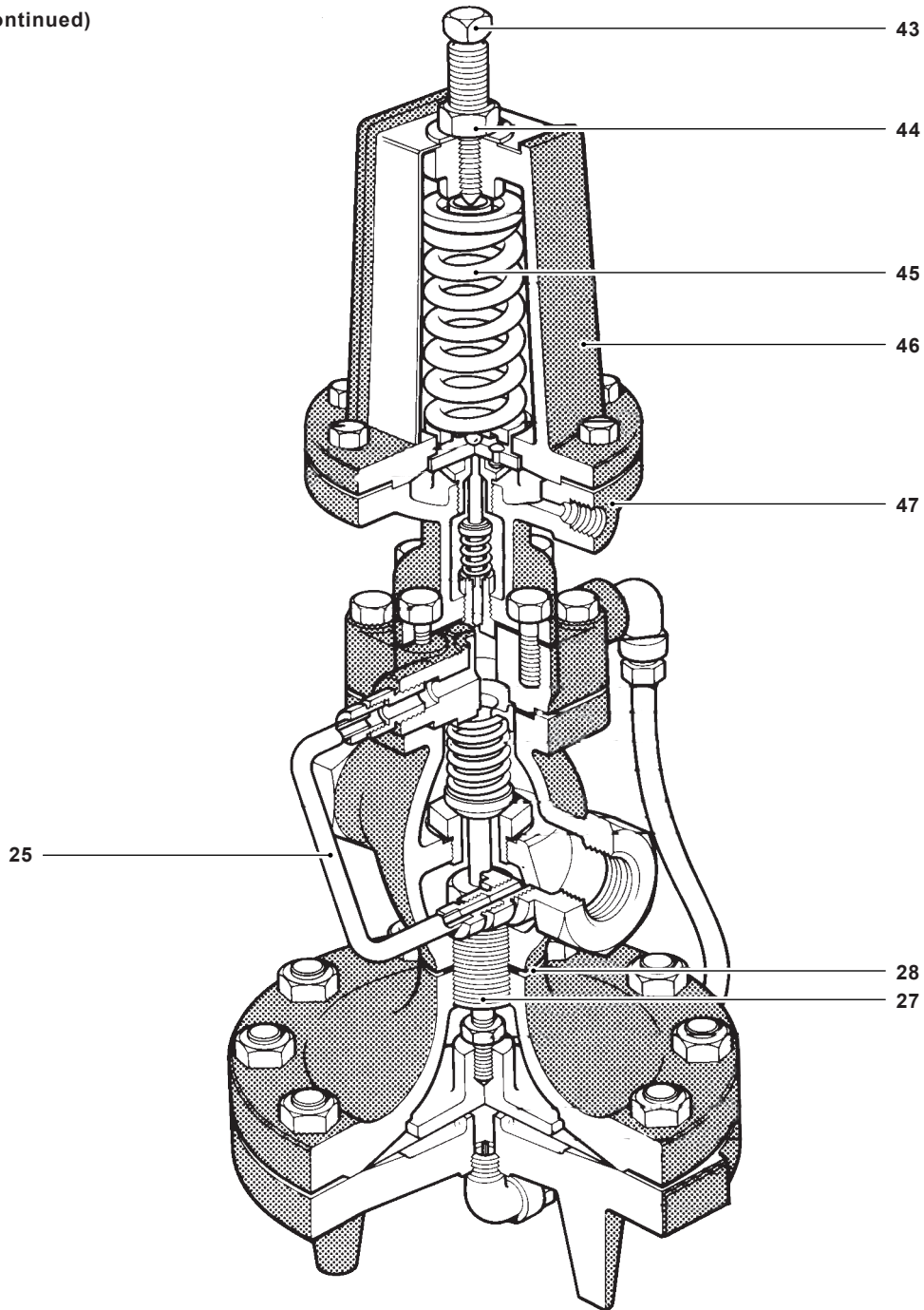

No.	Part	Material
25	Tubing Assembly Cast Iron	Copper / Brass
	Tubing Assembly Cast Steel	Stainless Steel
27	Connector Stud	Stainless steel
28	Body Gasket	1/2" - 2" (DN15 to DN50) Copper Clad
		2"* - 4" (DN50 to DN100) Graphite
43	Adjustment Screw	Stainless steel
44	Jam Nut	Brass
45	Pilot Valve Spring	Steel
46	Upper Diaphragm Case	Cast iron
		Cast steel

**Materials continued on next page**

**Materials** (continued)

1/2" to 2"

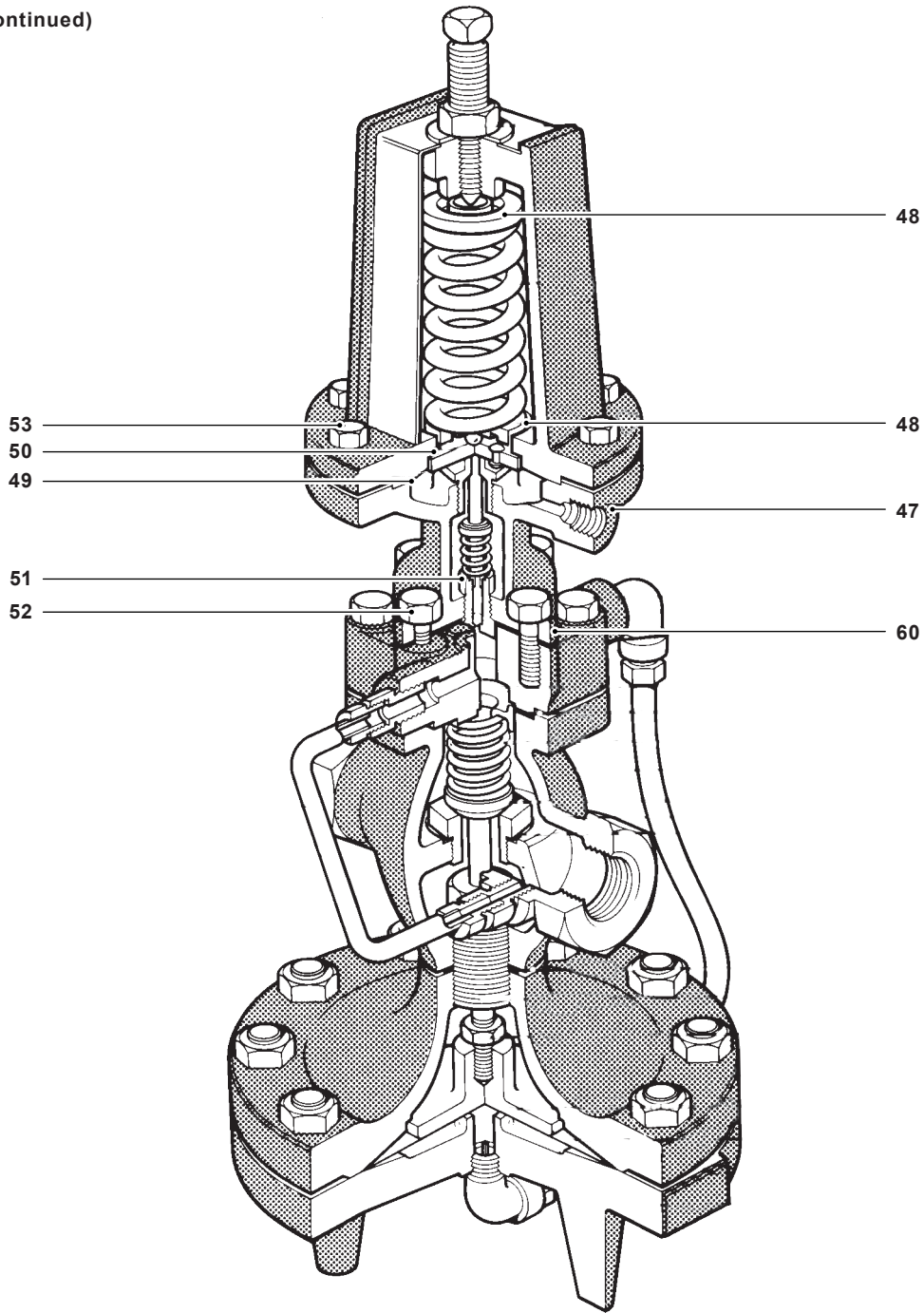

No.	Part	Material
47	Lower Diaphragm Case	Cast iron
		Cast steel
48	Spring Plate	Steel <span style="float: right;">ASTM A569</span>
49	Diaphragm	Stainless steel
50	Diaphragm Plate	Brass
51	Head and Seat assembly	Stainless steel
		Stainless steel
52	Pilot Mounting Screws	Steel <span style="float: right;">ASTM A449</span>
53	Diaphragm case screws	Steel
60	Pilot Gasket	Graphite

## Materials

2" to 4"

\*ANSI 300 ONLY

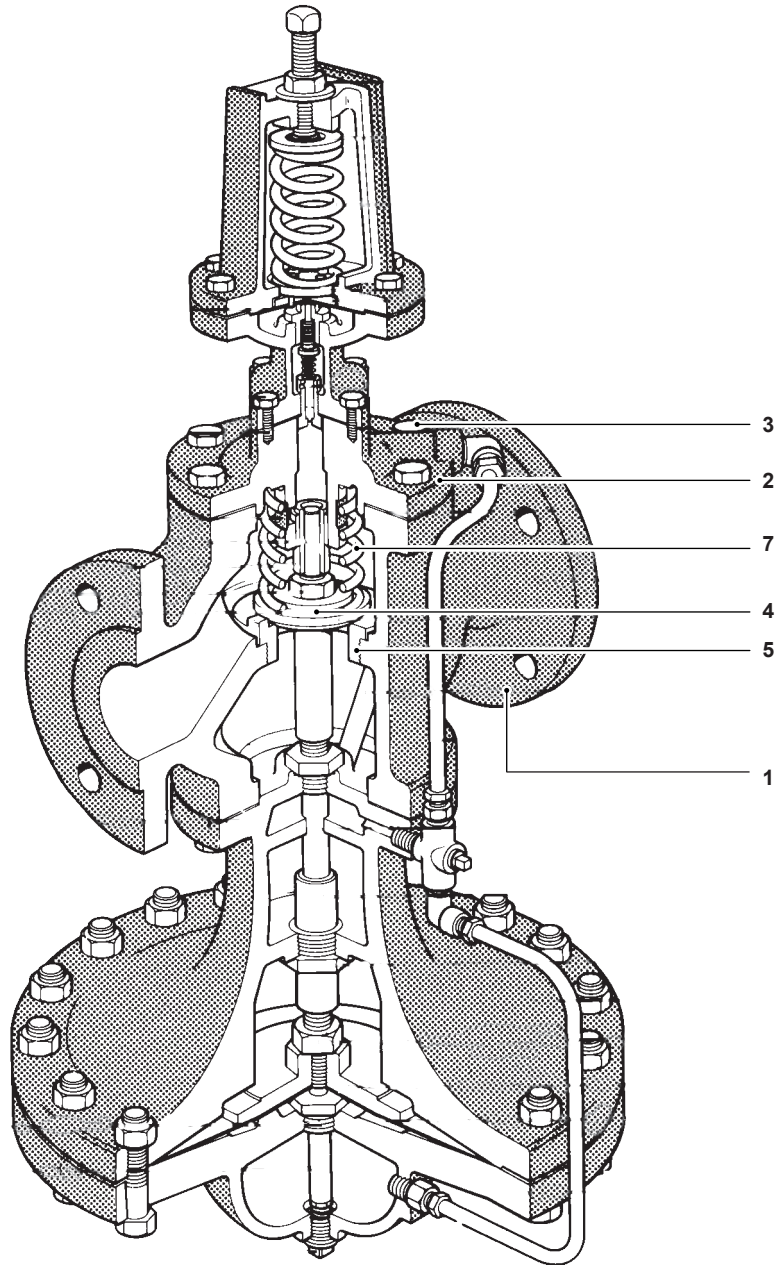

No.	Part	Material
1	Valve Body	Cast iron ASTM A 126 CL B
		Cast steel ASTM A216 Gr WCB
2	Cover	Cast iron ASTM A 126 CL B
		Cast steel ASTM A216 Gr WCB
3	Cover Bolts	Steel ASTM A449
4	Main Valve Head	Stainless steel 400 Series Stn Stl
5	Main Valve Seat	Stainless steel
6	Main Valve Seat Gasket	Copper
7	Valve Return Spring	Stainless steel

Materials continued on next page

**Materials (continued)**

**2" to 4"**

**\*ANSI 300 ONLY**

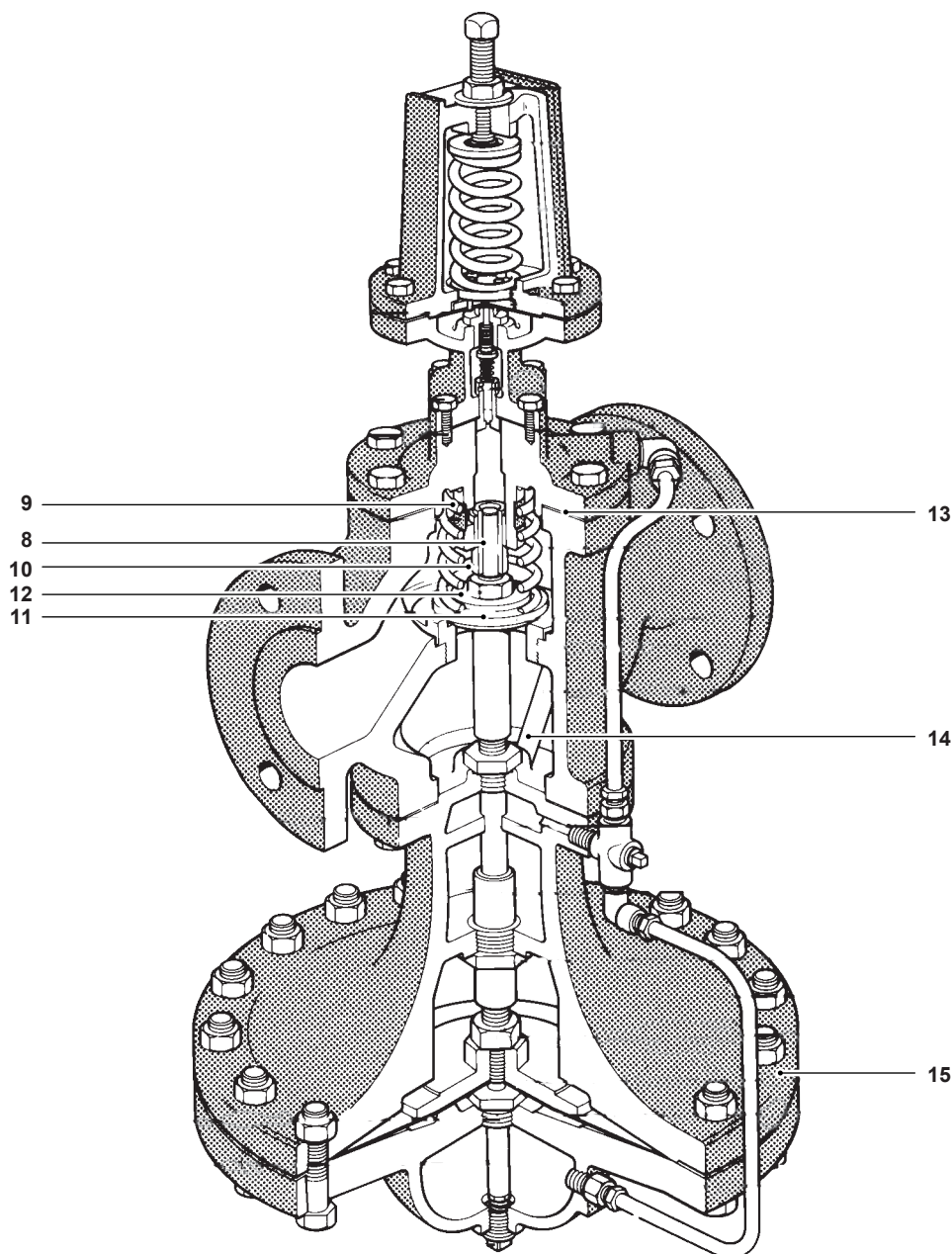

No.	Part	Material
8	Valve Stem	Stainless steel
9	Strainer Screen	Stainless steel
10	Valve Stem Sleeve	Stainless steel
11	Spring Guide	Cast iron 1/2"-2" (DN15 to DN50) CRS 2" - 4" (DN50 to DN100)
12	Nut	Steel
13	Cover Gasket	Graphite
14	Pressure Equalizer Pipe	Stainless steel
15	Upper Diaphragm Case	Cast iron <span style="float: right;">ASTM A 126 CL B</span> Cast steel <span style="float: right;">ASTM A216 Gr WCB</span>

**Materials continued on next page**

**Materials** (continued)

**2" to 4"**

\*ANSI 300 ONLY

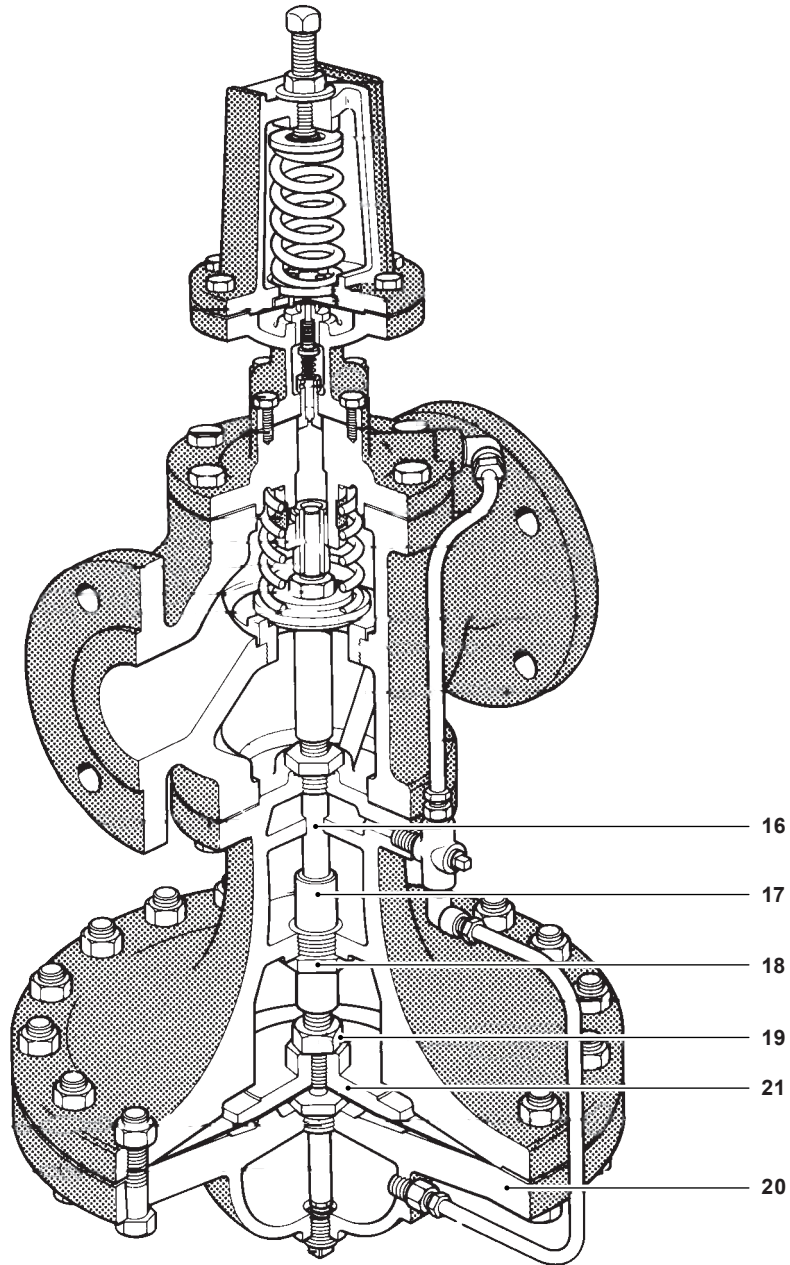

No.	Part	Material
16	Stem Bushing (2½" - 4" (DN65 to DN100) Cast steel only)	Stainless steel
17	Diaphragm Plate Stem	Stainless steel
18	Diaphragm Stem Guide	Stainless steel
19	Nut	Brass ½" - 2" (DN15 to DN50) Steel 2" - 4" (DN50 to DN100)
20	Lower Diaphragm Case	Cast iron <span style="float: right;">ASTM A 126 CL B</span> Cast steel <span style="float: right;">ASTM A216 Gr WCB</span>
21	Diaphragm Plate	Brass ½" - 2" (DN15 to DN50) C.I. 2" - 4" (DN50 to DN100)

**Materials continued on next page**

**Materials** (continued)

**2" to 4"**

\*ANSI 300 ONLY

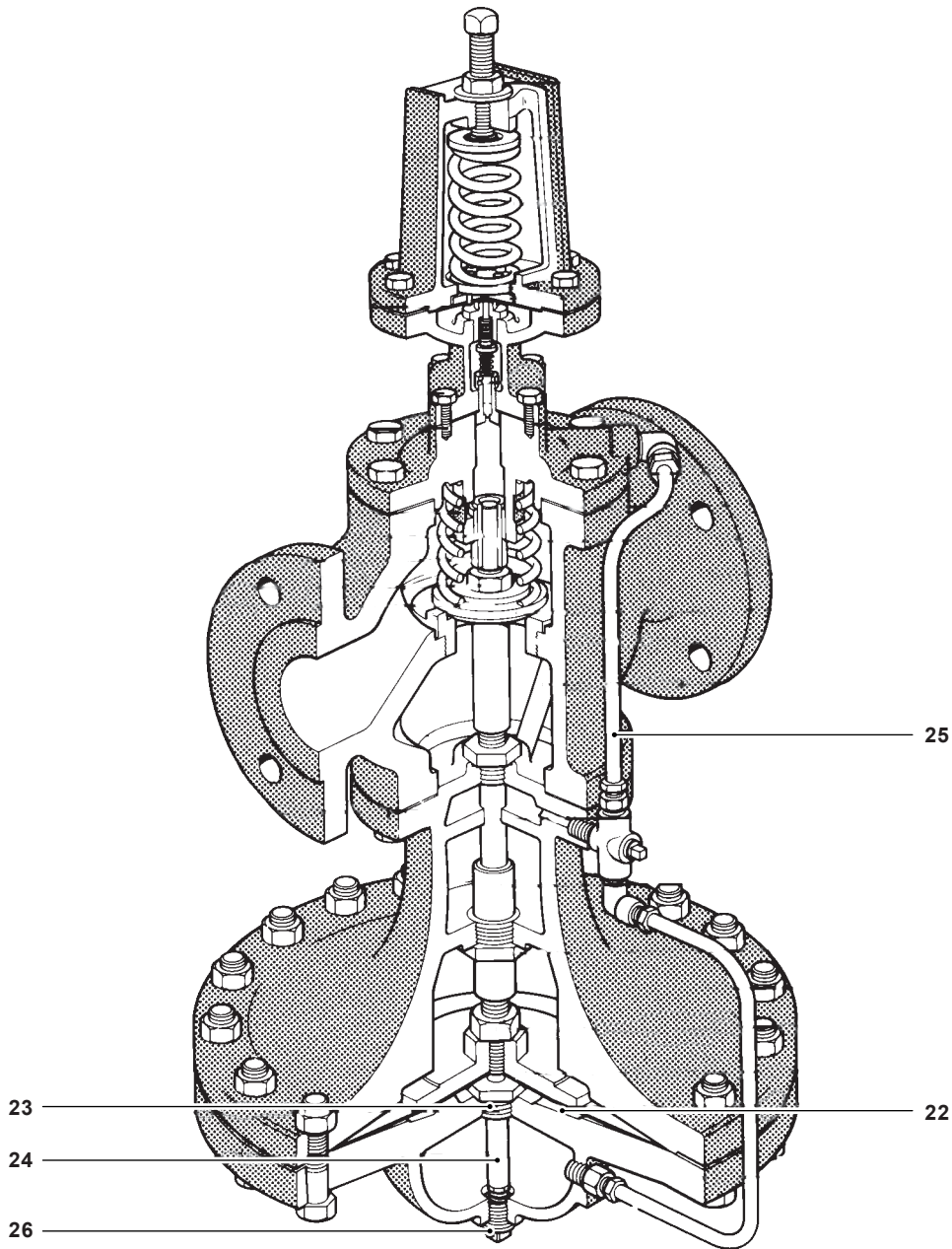

No.	Part	Material	
22	Main Diaphragm (2 ply)	Stainless steel	
23	Bushing	CRS	
24	Tube & Orifice	Brass	
25	Tubing Assembly Cast Iron	Copper / Brass	
	Tubing Assembly Cast Steel	Stainless Steel	
26	Plug	(Cast iron)	Brass
		(Cast steel)	Steel

Materials continued on next page

**Materials (continued)**

**2" to 4"**

**\*ANSI 300 ONLY**

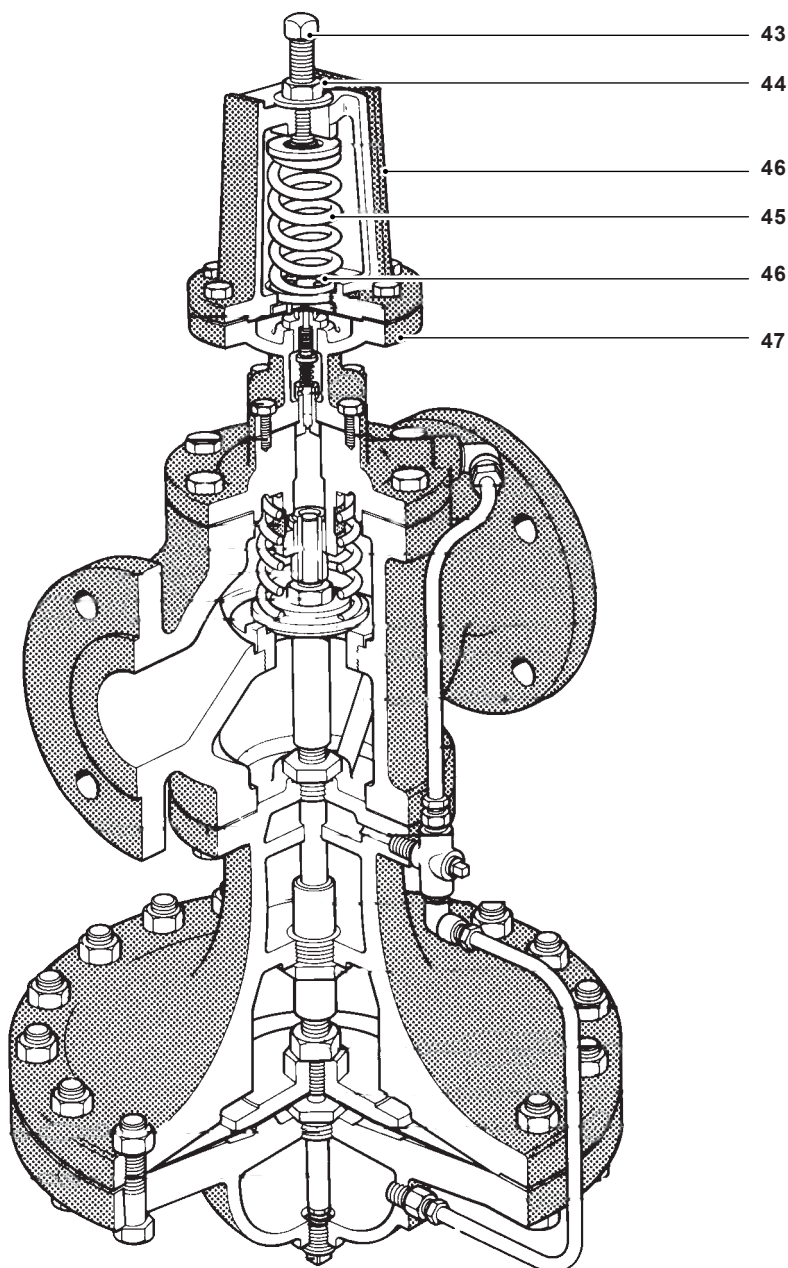

No.	Part	Material
43	Adjustment Screw	Stainless steel
44	Jam Nut	Brass
45	Pilot Valve Spring	Steel
46	Upper Diaphragm Case	Cast iron
		Cast steel
47	Lower Diaphragm Case	Cast iron
		Cast steel

**Materials continued on next page**

**Materials** (continued)

**2" to 4"**

\*ANSI 300 ONLY

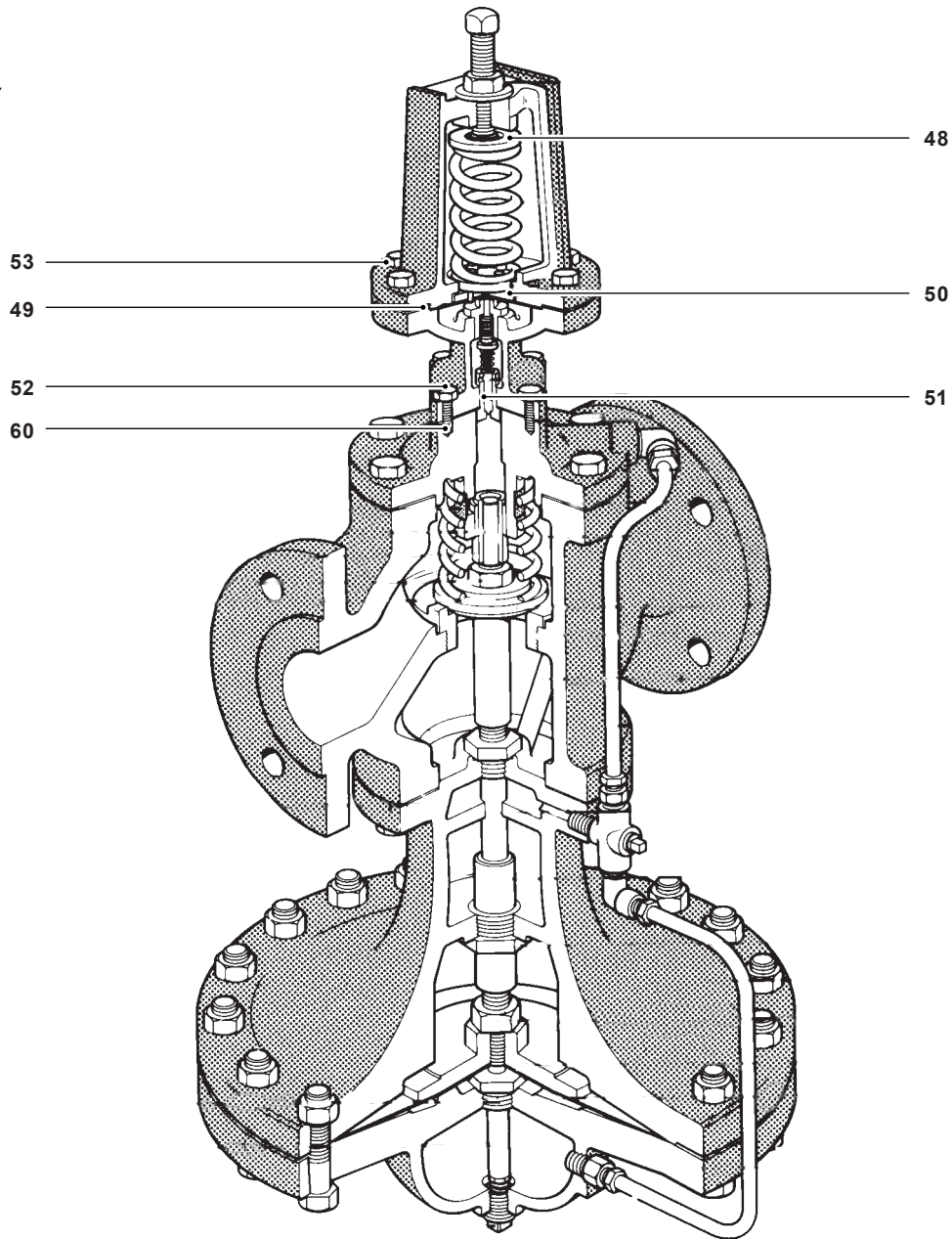

No.	Part	Material	
48	Spring Plate	Steel	ASTM A569
49	Diaphragm	Stainless steel	
50	Diaphragm Plate	Brass	
51	Head and Seat assembly	Stainless steel	
		Stainless steel	
52	Pilot Mounting Screws	Steel	ASTM A449
53	Diaphragm case screws	Steel	
60	Pilot Gasket	Graphite	

**Materials continued on next page**

**Dimensions/weights (approximate) in inches (mm) and lbs (kg)**

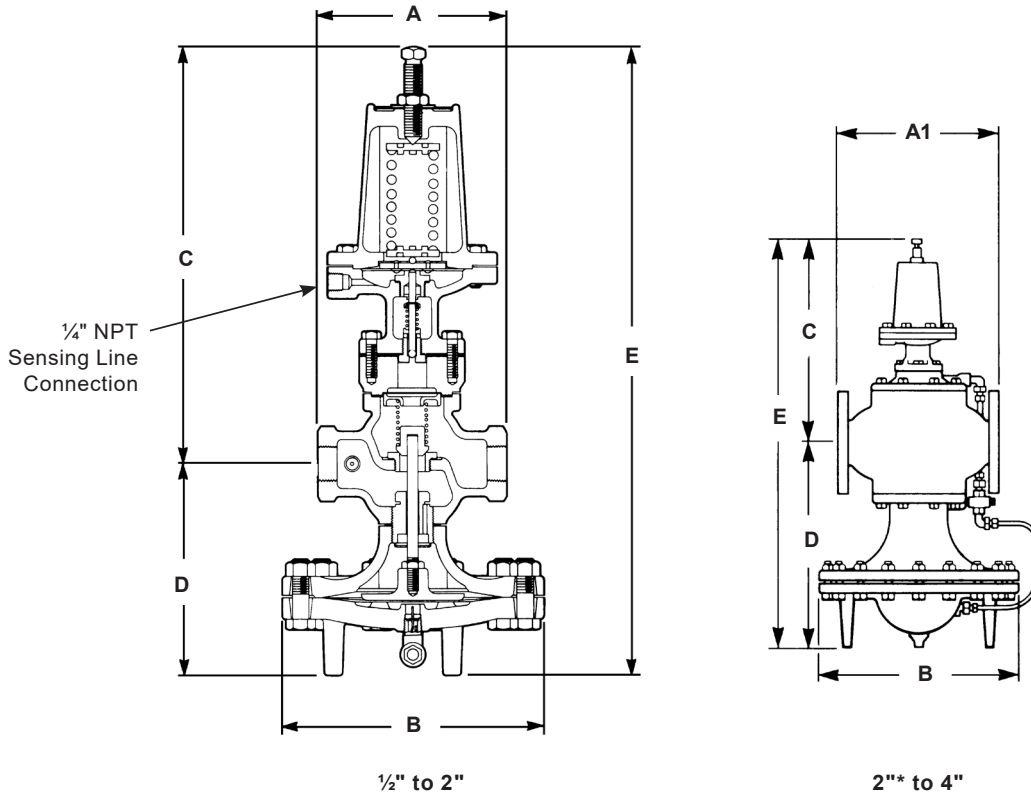

Size	ANSI 125		ANSI 250 ANSI 300		C	D	E	Weight	
	A	A1	A1	B				Cast iron	Cast steel
1/2", 3/4"	5.5	-	-	7.6	12.2	6.2	18.4	32 lb	35 lb
	(140)	-	-	(193)	(310)	(157)	(467)	(14.5 kg)	(15.9 kg)
1"	6.0	-	-	8.6	12.1	6.75	18.9	39 lb	43 lb
	(152)	-	-	(219)	(308)	(171)	(480)	(17.7 kg)	(19.5 kg)
1 1/4", 1 1/2"	7.25	-	-	8.6	12.7	7.1	19.75	44 lb	48 lb
	(184)	-	-	(219)	(323)	(180)	(502)	(20 kg)	(21.8 kg)
2"	8.5	-	9.0	10.6	13.3	8.2	21.5	69 lb	75 lb
	(216)	-	(229)	(270)	(338)	(208)	(546)	(31.3 kg)	(34 kg)
2 1/2"	-	10.9	11.5	13.6	14.0	13.9	27.9	157 lb	171 lb
	-	(276)	(292)	(346)	(356)	(353)	(709)	(71.2 kg)	(77.6 kg)
3"	-	11.75	12.5	13.6	13.9	14.4	28.4	188 lb	205 lb
	-	(298)	(318)	(346)	(353)	(365)	(721)	(85.3 kg)	(93 kg)
4"	-	13.9	14.5	15.6	15.25	16.1	31.4	284 lb	309 lb
	-	(353)	(368)	(397)	(387)	(409)	(797)	(129 kg)	(140 kg)

## Capacities:

For selection and sizing data, see TI-P717-07-US.

## Installation

The regulator should be installed in a horizontal line with suitable bypass and isolating valves. A steam trap should be installed upstream to prevent condensate from reaching the regulator. The trap and regulator should both be protected with a strainer. The pressure sensing line should be located either in the upstream piping, or in the steam space. Complete installation instructions are given in IM-3-023-US.

## Maintenance

Complete installation and maintenance instructions are given in IM-3-023-US, a copy of which is supplied with each regulator. Available spare parts are shown on TI-P717-09-US and TI-P235-02-US.

## Sample specification

The back pressure regulator shall be of the pilot-actuated, diaphragm-operated type. The main valve shall be single seated with hardened stainless steel trim; the valve body shall be cast iron (cast steel). The pilot shall be bolted directly to the valve body.

Standard Transmission tubing for Cast Iron Valve will be Copper with Brass fittings.

Standard Transmission tubing for Cast Steel Valve will be Stainless Steel.

If a different material is required order the Spare Part Kit

### Stainless Steel Transmission Tubing Kits

Item #	Size	Description
71464	½", ¾"	Kit, ½"-¾", 25 Valve, Stainless Steel, Transmission tubing
71465	1"	Kit, 1", 25 Valve, Stainless Steel, Transmission tubing
71466	1¼", 1½"	Kit, 1¼"-1½", 25 Valve, Stainless Steel, Transmission tubing
71467	2"	Kit, 2", 25 Valve, Stainless Steel, Transmission tubing
71468	2½"	Kit, 2½", 25 Valve, Stainless Steel, Transmission tubing
71469	3"	Kit, 3", 25 Valve, Stainless Steel, Transmission tubing
71470	4"	Kit, 4", 25 Valve, Stainless Steel, Transmission tubing

### Copper Tubing Transmission Line Kits

Item #	Size	Description
57302	½", ¾"	Transmission tubing kit, ½"-¾", 25 Valve
57303	1"	Transmission tubing kit, 1", 25 Valve
57304	1¼", 1½"	Transmission tubing kit, 1¼"-1½", 25 Valve
57305	2"	Transmission tubing kit, 2", 25 Valve
58010	2½"	Transmission tubing kit, 2½", 25 Valve
58011	3"	Transmission tubing kit, 3", 25 Valve
58012	4"	Transmission tubing kit, 4", 25 Valve