

FTC23 and FTS23 Float Trap

The steam trap solution for heavily contaminated steam applications

The FT23 provides a reliable and cost effective steam trapping solution for dirty and corrosive condensate streams. Lasting considerably longer than conventional float traps, the FT23 is at home in contaminated systems, effectively resisting fouling to reduce overall cost of ownership. The FT23 is available in two models, the FTC23 in carbon and stainless steel and the FTS23 in stainless steel throughout.

Compared to conventional float traps the FTC23 will:

- Reduce your maintenance requirements**
 Self purging discharge action
- Lower your costs and trap replacement frequency**
 Highly resistant to corrosion and erosion
- Reduce downtime**
 External lever allows you to manually clear blockages without decommissioning the line.



Range overview	FTC23		FTS23	
Body Material	Carbon Steel		Stainless Steel	
Cover and Internals material	Stainless Steel		Stainless Steel	
Size	1½" (DN40)	2" (DN50)	1½" (DN40)	2" (DN50)
Pipeline Connections				
ASME 150	•	•	•	•
ASME 300	•	•	•	•
Manual Lever	•	•	•	•

Innovative self-cleaning float mechanism

The new design of the plug and seat assembly resists the build-up of debris and allows the automatic safe operation even in the presence of severe steam contamination. The position and size of the main valve and seat makes it easier for the discharge of condensate and solid contaminant. The FT23 is able to modulate the condensate flow, adapting immediately to sudden and large variations of flow and pressure.

Manual blockage clearance lever

The external lever allows the operator to manually open the valve to purge the interior and remove any build-up of contaminants. This helps the trap to maintain optimum performance inline without a lengthy maintenance period and decommissioning of the steam line.

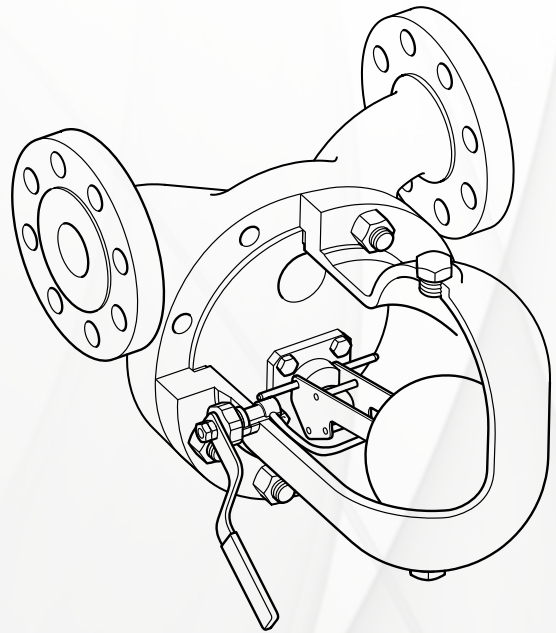

For more information visit spiraxsarco/global/us.com

spirax
sarco

Spirax Sarco U.S.
1150 Northpoint Blvd., Blythewood, SC 29016
T 800-883-4411
www.spiraxsarco.com/global/us

SB-P605-03-US



© Copyright 2017 Spirax Sarco is a registered trademark of Spirax-Sarco Limited