

VTD
Venturi Type desuperheater
Installation and Maintenance Instructions



1. Safety information
2. Introduction
3. General product information
4. Inspection and performance confirmation
5. Installation
6. Operation
7. Maintenance
8. Troubleshooting

1. Safety information

Safe operation of these products can only be guaranteed if they are properly installed, commissioned, used and maintained by qualified personnel (see Section 1.11) in compliance with the operating instructions. General installation and safety instructions for pipeline and plant construction, as well as the proper use of tools and safety equipment must also be complied with.

1.1 Intended use

Referring to the Installation and Maintenance Instructions, name-plate and Technical Information Sheet, check that the product is suitable for the intended use/application. The products listed below comply with the requirements of the European Pressure Equipment Directive 2014/68/EU and carry the mark when so required.

The products fall within the Pressure Equipment directive categories as shown below:

Application	Group 2 Gases	Group 2 Liquids
Steam	Will not exceed Cat. 3	-
Water	-	Will not exceed Cat. 2

- i) The products have been specifically designed for use on steam which is in Group 2 of the above mentioned Pressure Equipment directive.
- ii) Check material suitability, pressure and temperature and the maximum and minimum design pressure and design temperature values on the product nameplate. If the maximum operating limits of the product are lower than those of the system in which it is being fitted, or if malfunction of the product could result in a dangerous overpressure or over-temperature occurrence, ensure a safety device is included in the system to prevent such over-limit situations.
- iii) Determine the correct installation situation and direction of fluid flow.
- iv) Spirax Sarco products are not intended to withstand external stresses that may be induced by any system to which they are fitted. It is the responsibility of the installer to consider these stresses and take adequate precautions to minimise them.
- v) Remove protective covers from all connections and protective film from all name-plates, where appropriate, before installation on steam and water lines.

1.2 Access

Ensure safe access and if necessary a safe working platform (suitably guarded) before attempting to work on the product. Arrange suitable lifting gear if required.

1.3 Lighting

Ensure adequate lighting, particularly where detailed or intricate work is required.

1.4 Hazardous liquids or gases in the pipeline

Consider what is in the pipeline or what may have been in the pipeline at some previous time. Consider: flammable materials, substances hazardous to health, extremes of temperature.

1.5 Hazardous environment around the product

Consider: explosion risk areas, lack of oxygen (e.g. tanks, pits), dangerous gases, extremes of temperature, hot surfaces, fire hazard (e.g. during welding), excessive noise, moving machinery.

1.6 The system

Consider the effect on the complete system of the work proposed. Will any proposed action (e.g. closing isolation valves, electrical isolation) put any other part of the system or any personnel at risk?

Dangers might include isolation of vents or protective devices or the rendering ineffective of controls or alarms. Ensure isolation valves are turned on and off in a gradual way to avoid system shocks.

1.7 Pressure systems

Ensure that any pressure is isolated and safely vented to atmospheric pressure. Consider double isolation (double block and bleed) and the locking or labelling of closed valves. Do not assume that the system has depressurised even when the pressure gauge indicates zero.

1.8 Temperature

Allow time for temperature to normalise after isolation to avoid danger of burns.

1.9 Tools and consumables

Before starting work ensure that you have suitable tools and/or consumables available. Use only genuine Spirax Sarco replacement parts.

1.10 Protective clothing

Consider whether you and/or others in the vicinity require any protective clothing to protect against the hazards of, for example, chemicals, high/low temperature, radiation, noise, falling objects, and dangers to eyes and face.

1.11 Permits to work

All work must be carried out or be supervised by a suitably competent person.

Installation and operating personnel should be trained in the correct use of the product according to the Installation and Maintenance Instructions.

Where a formal 'permit to work' system is in force it must be complied with. Where there is no such system, it is recommended that a responsible person should know what work is going on and, where necessary, arrange to have an assistant whose primary responsibility is safety. Post warning notices if necessary.

1.12 Handling

Manual handling of large and/or heavy products may present a risk of injury. Lifting, pushing, pulling, carrying or supporting a load by bodily force can cause injury particularly to the back. You are advised to assess the risks taking into account the task, the individual, the load and the working environment and use the appropriate handling method depending on the circumstances of the work being done.

1.13 Residual hazards

In normal use the external surface of the product may be very hot. If used at the maximum permitted operating conditions the surface temperature of some products may reach temperatures of 590 °C (1094 °F).

Many products are not self-draining. Take due care when dismantling or removing the product from an installation (refer to 'Maintenance instructions').

1.14 Freezing

Provision must be made to protect products which are not self-draining against frost damage in environments where they may be exposed to temperatures below freezing point.

1.15 Disposal

Unless otherwise stated in the Installation and Maintenance Instructions, this product is recyclable and no ecological hazard is anticipated with its disposal providing due care is taken.

Please visit the Spirax Sarco product compliance web pages

<https://www.spiraxsarco.com/product-compliance>

for up to date information on any substances of concern that may be contained within this product. Where no additional information is provided on the Spirax Sarco product compliance web page, this product may be safely recycled and/or disposed providing due care is taken. Always check your local recycling and disposal regulations.

1.16 Returning products

Customers and stockists are reminded that under EC Health, Safety and Environment Law, when returning products to Spirax Sarco they must provide information on any hazards and the precautions to be taken due to contamination residues or mechanical damage which may present a health, safety or environmental risk. This information must be provided in writing including Health and Safety data sheets relating to any substances identified as hazardous or potentially hazardous.

2. Introduction

2.1 General

This document presents the installation, operation and maintenance instructions for venturi type desuperheaters - VTD.

This document should be read in conjunction with the General arrangement drawing of the desuperheater.

3. General product information

Direct contact desuperheaters reduce the temperature of superheated steam to produce steam temperatures approaching saturation temperature (typically to within 3 °C of the saturation temperature). To cool the superheated steam water is entrained and flashed into vapour by absorbing heat from the steam.

It contains no moving parts and is therefore very simple in operation.

3.1 Construction

The VTD venturi type desuperheater is an in-line mounted unit and has end connections which make it suitable for connecting directly into the steam pipework. The connections are either flanged or butt weld ends for welding into the pipeline by others.

The construction of the VTD depends upon its size.

Above 2" NB:-

For units above 2" in size (which incidentally is the vast majority) the VTD comprises an external shell containing a number of internal components. It is the design of the internal components which give the unit its specific operating characteristics.

These components are referred to as 1) the nozzle, 2) the internal diffuser, 3) the internal housing and 4) the main diffuser. The nozzle and the internal diffuser are removable items, generally screwed into the internal housing. At large VTD sizes (typically above 12"), the nozzle and internal diffuser are welded to the internal housing as the use of screw threads becomes impractical at larger thread sizes.

The venturi principle is used to create regions of high velocity and turbulence which produces intimate contact between the steam and cooling water.

The region of the internal diffuser which is located within the internal housing contains a number of small holes which allow cooling water to pass into the steam via the internal diffuser.

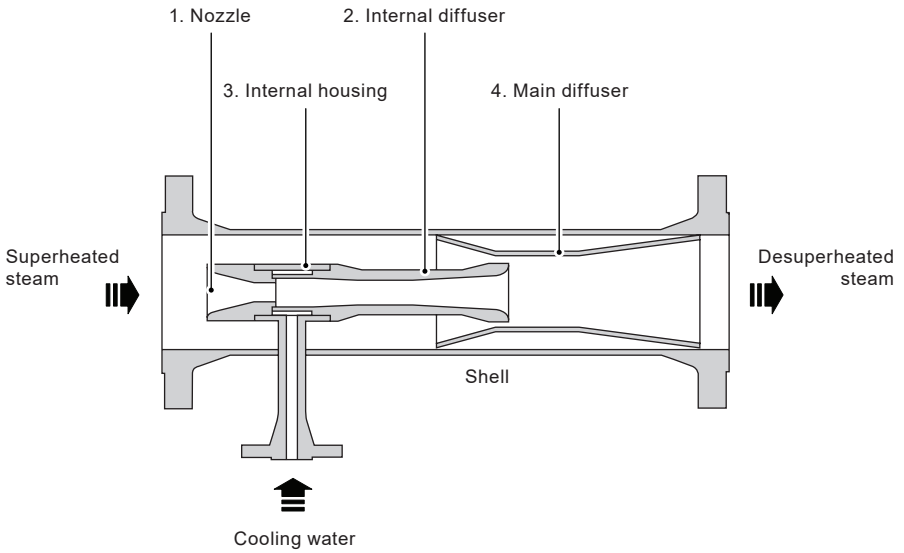

Fig. 1

There is a series of three internal seals/gaskets within the VTD which prevent cooling water passing into the steam flow other than through these holes. The location of these seals is shown in the General Arrangement drawing in Section 3.2.

3.2 Typical VTD multi-nozzle arrangement

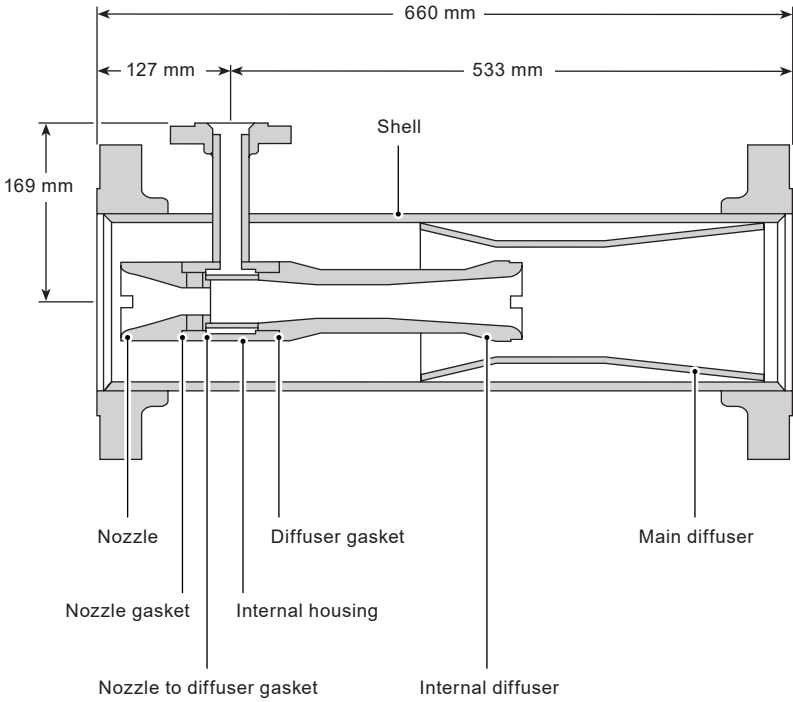

Fig. 2 General arrangement drawing of a size 6 venturi type desuperheater (cross section through centreline)

3.3 Materials of construction

Component	Mechanical design temperature up to and including 425 °C	Mechanical design temperature above 425 °C up to and including 590 °C
Shell	Sizes 1 to 2: ASTM A350 LF2N Size 3 and above: ASTM A106 Grade B	Sizes 1 to 2: ASTM A182 F11 Size 3 and above: ASTM A335 P11
Water branch	Sizes 1 to 2: ASTM A350 LF2N Size 3 and above: ASTM A106 Grade B	Sizes 1 to 2: ASTM A182 F11 Size 3 and above: ASTM A335 P11
Flanges	Sizes 1 to 2: ASTM A350 LF2N Size 3 and above: ASTM A105N	ASTM A182 F11
Nozzle	ASTM A182 F316L	ASTM A182 F11
Internal diffuser	Sizes 1 to 2: Not Applicable Size 3 and above: ASTM A182 F316L	Sizes 1 to 2: Not Applicable Size 3 and above: ASTM A182 F11
Internal housing	Sizes 1 to 2: Not Applicable Size 3 and above: ASTM A350 LF2N	Sizes 1 to 2: Not Applicable Size 3 and above: ASTM A182 F11
Main diffuser	Sizes 1 to 4: ASTM A350 LF2N Sizes 6 and 8: ASTM A240/ ASTM A312 316L Size 10: BS EN 10130:2006 dC01 Size 12 and above: ASTM A516 Gr70	Sizes 1 to 4: ASTM A182 F11 Size 6 and above: ASTM A387 Gr11
Internal seals	Soft copper	Soft copper

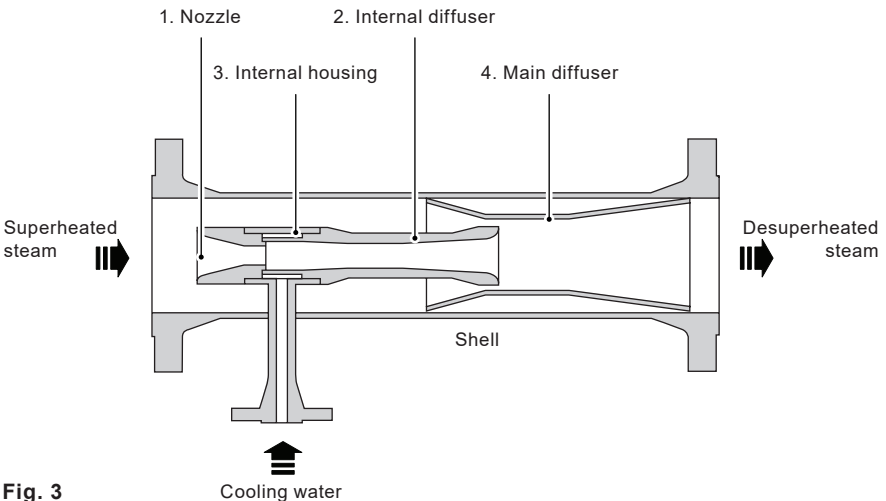

Fig. 3

VTD Venturi Type desuperheater

3.4 Mechanical design temperature and flange rating

<374 °C	ASME 150, ASME 300 and ASME 600 + PN16, PN25 and PN40 Slip-on (Weld neck optional)
374 - 525 °C	ASME 150, ASME 300 and ASME 600 + PN16, PN25 and PN40 Weld neck (Slip-on N/A)
375 - 590 °C	ASME 300, ASME 600, ASME 900 and ASME 1500 + PN10, PN16, PN25, PN40, PN63 and PN100

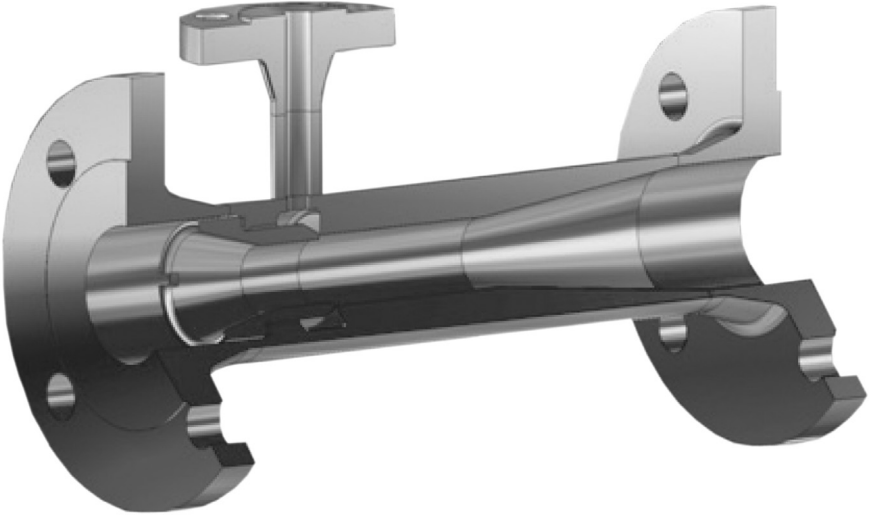

Fig. 4 Typical view of Size 2 VTD venturi type desuperheater

At sizes smaller than 2" NB, it has been found that a 'block-body' type of design becomes more economical. In this type of design, the entire VTD is machined from a single block of material. A General Arrangement drawing and model for a size 1¼ (1¼" steam connection sizes) is shown in Section 3.5.

3.5 Typical VTD multi-nozzle arrangement

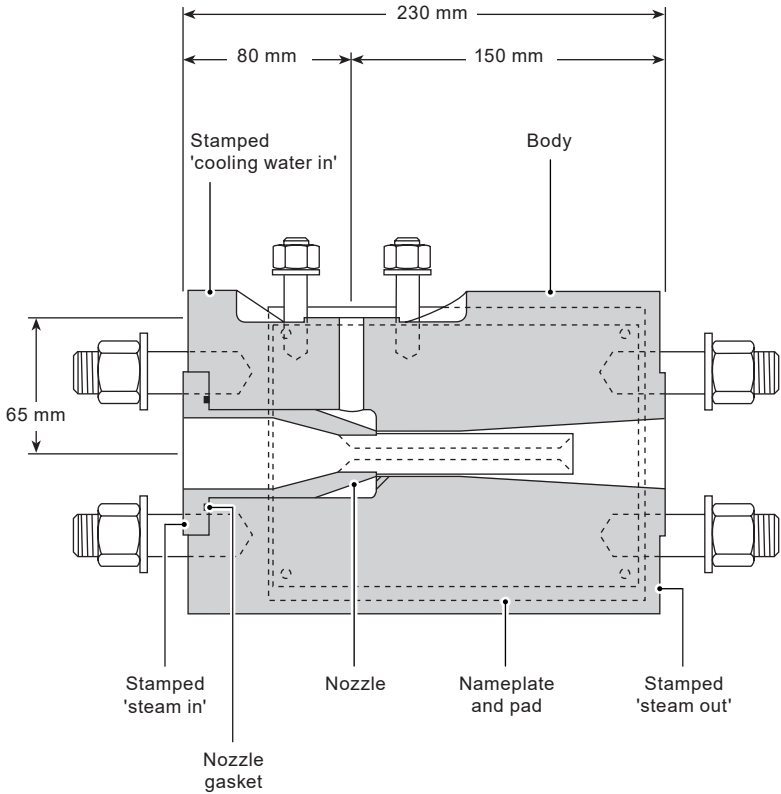

Fig. 5 General arrangement drawing of a size 1¼ venturi type desuperheater (cross section through centreline)

Special Note: For all configurations, the bores and profiles of the nozzle, internal diffuser and main diffuser are specifically calculated and designed for each application. In this way, the VTD is tailored to suit each individual application.

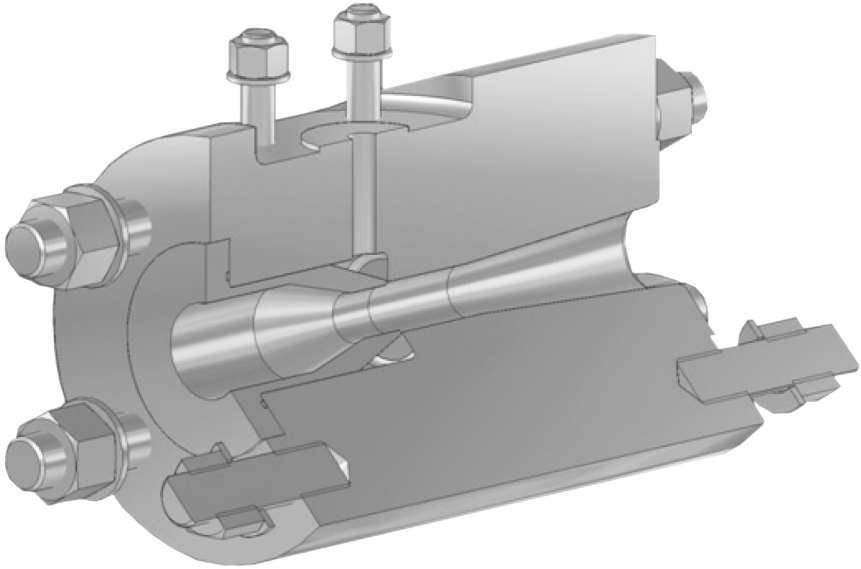

Fig. 6

3.6 Thermal performance and turndown

The achievable turndown depends upon actual operating conditions, but generally, for horizontal installations, accurate control at 3 °C above saturation (3 °C residual superheat) is possible at turndowns of up to 4:1. This increases to 5:1 for installations in which the steam flowrate is vertically upwards.

3.7 Cooling water supply

The flow of cooling water into the VTD is regulated by the number and size of water holes and the pressure drop across them.

Suitable for most general plant applications except where high turndowns on cooling water are required.

4. Inspection and performance confirmation

4.1 Receiving inspection

Although Spirax Sarco carry out full inspection of all Units before despatch, damage may have occurred during transit. On receipt of the unit, a visual inspection will highlight any external damage and hence indicate any internal damage that may have occurred. If this is the case please contact us immediately.

4.2 User's rating inspection

Before installing the VTD, the user must ensure the mechanical rating of the unit is suitable for the intended service.

Details of the mechanical rating can be found on the nameplate and associated documentation for the unit.

5. Installation

Note: Please read Section 1, 'Safety information' before proceeding with installation.

5.1 General

It is important that installation should only be carried out by qualified, experienced personnel, who are familiar with the fitting of Venturi Type desuperheaters, and who have read and understood the instructions in this IM.

5.2 Installation considerations

5.2.1 Steam piping upstream of the desuperheater

- a) The pipe size should be the same as the desuperheater steam inlet connection.
- b) The associated PRV is usually smaller than the desuperheater connection size. We recommend eccentric pipe reducers are used to achieve the change in size.
- c) Where noise from the PRV is expected to be a problem, consider making this pipe thicker than that required to just contain the pressure. This will help reduce noise levels emitted to atmosphere. Under extreme conditions this pipe may have to be acoustically insulated. This, however is very rare indeed.
- d) The distance between the PRV and inlet to the VTD should be as short as possible but long enough to have eliminated valve turbulence at the inlet to the desuperheater. The rule of thumb is that this distance should be five times the diameter of the desuperheater inlet or 1.5 metres, whichever is the longer. If the PRV and desuperheater are too close or if the PRV is too close to a pipe bend or other fitting, then turbulence may cause noise and vibration.

5.2.2 Discharge steam piping

- a) The size should be the same as the desuperheater steam outlet connection.
- b) The distance between the desuperheater discharge connection and the location of the temperature sensor must be long enough to allow complete evaporation of the cooling water ahead of the sensor. If the sensor is too close to the desuperheater discharge, evaporation of the cooling water will not be complete and the sensor will give a false reading, with corresponding poor temperature control.
- c) This pipe should be straight, free of bends and contain no restrictions. We recommend a minimum straight length distance of 2.5 to 7.5 m depending on the amount of residual superheat required (specified in table below). The greater the amount of residual superheat required, the faster the water droplets are evaporated and the shorter the distance required.
- d) The table below specifies the minimum straight distance required between the desuperheater outlet and the temperature sensor versus residual superheat.

Amount of residual superheat	Minimum straight length distance to temperature sensor
3 - 5 °C	7.50 m
10 °C	6.80 m
15 °C	6.25 m
30 °C	5.00 m
50 °C	3.70 m
100 °C	2.50 m

- e) If bends or restrictions are placed in this pipework within the specified distance, before the droplets have had chance to evaporate, inertia causes the droplets to separate out from the main steam flow and run along the bottom or side wall of the pipe. Contact between the steam and cooling water is lost and desuperheating is halted.
- f) Use thermal insulation over this pipe section to help prevent false temperature readings (condensation can still occur on the walls of a 50 °C superheated steam line). Measurement error can be quite large, especially at low flow rates when heat lost through condensation is a high percentage of total heat energy in the line.

5.2.3 Temperature sensor

- a) Speed of controlled response is important. For this reason, thermocouples or resistance thermometers are usually employed.
- b) The size of an associated thermowell is important. Ones with large mass slow down rate of heat transfer and can cause serious measurement time lags. At low flow rates the problem is worse. Sometimes it's sufficient to simply improve contact between the sensor and well. But in other cases a special well may be needed, such as an extended-surface type. Recommendations should be sought from the instrument supplier.
- c) The temperature sensor should be positioned on the uppermost surface of a horizontal installation.

5.2.4 Pressure sensor

This should be located at a minimum distance of 1.5 metres away from the desuperheater discharge flange. Ideally however, this should be located at the point of use so that the pressure control valve can compensate for any line loss between the desuperheater and the point of use.

5.2.5 Pressure relief valve (PSV)

In applications involving simultaneous pressure reduction and depending upon the pressure rating of the equipment, a safety relief valve to protect both the desuperheater and downstream equipment from the effects of excess pressure shall be considered. This could protect the desuperheater and downstream equipment if the PRV failed fully open for example.

5.2.6 Installation orientation

Desuperheaters may be installed either horizontally or vertically with the steam flowing upwards.

Spirax Sarco strongly advises against an installation in which the steam flow is vertically downwards.

In the case of a horizontal installation the cooling water connection should ideally point downwards, as this gives the best orientation for drainage of fluids in a shutdown situation.

Other orientations are acceptable for satisfactory operation, but drainage is not as effective.

In a vertical installation we recommend that, the cooling water pipework should be brought to the desuperheater from below the corresponding connections on the desuperheater. This arrangement will provide the best layout for drainage of fluids on shutdown.

5.2.7 Other installation considerations

a) Isolation valves:

To provide a shut-off facility and to allow maintenance to be carried out, isolation valves are recommended upstream of:

- The superheated steam pressure control valve.
- The cooling water control valve.

b) **Strainers:** depending on steam and cooling water quality, consider installing strainers in the lines in order to protect both the cooling water and steam valves as well as to prevent the small bores within the desuperheater from becoming blocked.

c) **Separator station:** In applications where there must be no moisture in the resulting steam (such as steam supply to a turbine or motive steam supply to a thermocompressor for example) it is recommended that a separator is installed downstream of the desuperheater system. This will protect downstream pipework and equipment from the effects of moisture in the event of a control system failure or from abnormal operating conditions, such as at start-up for example.

It is also considered prudent to install a separator station when desuperheating close to saturation temperature or for applications involving large steam turndowns. The separator must be located after the temperature sensor thereby giving the water droplets as much time as possible to evaporate.

The associated steam trap should be selected to prevent air binding and the discharge pipe from the steam trap should have ample capacity to deal with the drainage and be installed as near to the vertical as possible. There must be sufficient space in the drainpipe for the water to flow down and the air to pass up the pipe.

d) **Non Return Valve (NRV):** Consider the installation of an NRV in the cooling water line located immediately before the cooling water inlet connection to prevent back flow of steam into the cooling water inlet line in the event of either cooling water failure or excess pressure in the desuperheater caused by failure of the steam pressure reducing valve for example.

e) **Pressure tappings:** Include plugged pressure tappings within the connecting pipework which would allow gauges to be fitted to assist troubleshooting in the event of operational problems.

f) All connecting pipework must be sized in accordance with good working practice.

g) The termination points of the Spray Type desuperheater are not designed to be load bearing, therefore the client is responsible for ensuring that pipework loads are not transmitted to the connecting flanges of the desuperheater. We recommend that connecting pipework is supported from adjacent steelwork, to prevent loads being transmitted to the desuperheater.

h) Gaskets, valves, cocks and any in-line Instruments should not reduce the cross sectional area of the connecting pipelines. This is of particular importance in smaller bore pipework.

i) Ensure that low points of all interconnecting pipework have suitable connections for drains.

j) Ensure the system can be safely vented back to atmospheric pressure following a shut down.

k) Consider the installation of air vents to remove air on start-up.

5.3 Unit installation

5.3.1 Pre-installation check

- a) The gasket materials used for the installation must be compatible with the fluids passing through the desuperheater and must be suitable for the design conditions of the installation.
- b) Ensure that the connecting pipelines are clean and that all weld spatter and foreign bodies have been removed.
- c) Ensure the desuperheater is free of foreign bodies such as packing materials etc.

5.3.2 Installation

Only three connections into the connecting pipework are required:-

- a) The steam inlet connection is to be connected to the superheated steam line.
- b) The steam outlet connection is to be connected to the discharge line.
- c) The cooling water inlet connection is to be connected to the cooling water inlet line.

6. Operation

6.1 Unit operation

It contains no moving parts and is therefore very simple in operation.

This type of desuperheater employs restrictions that create regions of high velocity and turbulence that atomise then establish intimate contact between the steam and cooling water.

1. Pressurised cooling water enters the VTD through the cooling water branch then circulates within the annulus formed by the outside of the internal diffuser and inside of the internal housing.
2. The cooling water then passes from the annulus through a series of small holes into the internal diffuser. The number and size of these holes are determined by calculation. The use of a larger number of small holes than a smaller number of large holes assists the subsequent atomisation.
3. A calculated portion of the superheated enters the nozzle and is accelerated to a high velocity in the nozzle throat, dropping in pressure as it does so. The greater the pressure drop, the greater the velocity. It emerges from the nozzle as a high velocity jet of steam. The bore of the nozzle is determined by calculation.
4. The greater portion of superheated steam passes around the outside of the nozzle, internal housing and internal diffuser, towards the main diffuser.
5. The jet of steam leaving the nozzle enters the internal diffuser where its high velocity serves to atomise the incoming cooling water. The greater the pressure drop across the nozzle, the greater the velocity of the emerging steam jet and the better the resulting atomisation.
6. The mixture of cooling water and steam is intimately mixed at high turbulence as it moves along the internal diffuser. The internal profile of the internal diffuser is determined by calculation and promotes the turbulence, mixing and desuperheating in this region.
7. A saturated mist (or fog) emerges from the internal diffuser into the main diffuser throat.
8. The greater proportion of steam which did not pass through the nozzle enters the main diffuser, then is accelerated to a high velocity in the annular gap formed between the outside diameter of the internal diffuser and the inside diameter of the main diffuser. This steam is accelerated to the same velocity as that within the nozzle throat, dropping in pressure as it does so. This serves to balance or equalise the pressure of both streams as they enter the main diffuser throat.
9. The high velocity steam entering the main diffuser throat serves to create high turbulence in this area, thereby promoting further desuperheating.
10. The combined streams then pass out of the desuperheater into the discharge piping where the final desuperheating takes place.

6.2 Pre-operational check

- a) Check control system has been tested and is operational.
- b) Check relief valve (if fitted) has been tested and is fit for operation.
- c) Ensure all isolation valves (both steam and cooling water) are closed.
- d) Ensure that all line restrictions have been removed.
- e) Ensure that cooling water is available upstream of the cooling water isolation Valve.
- f) Take all precautions necessary to handle the possibility of leakage, both in terms of protection of personnel and nearby equipment.

6.3 Start-up procedure

The following start-up procedure should be considered as our initial recommendation as to how to start-up the desuperheater. It must be reviewed by the end user, preferably within a HAZOP, to determine whether it is consistent with the operating philosophy of the rest of the plant. The sequence of steps can be revised if necessary. However, the approach of ensuring the cooling water is made available to the desuperheater before admitting steam must be followed.

1. Activate the control system. The temperature control valve in the cooling water inlet line should close.
2. Open the cooling water isolation valve.
3. Open the steam isolation valve downstream the VTD. This may cause the desuperheater to pressurise, depending on the condition of the downstream system.
4. Very slowly open the upstream steam isolation valve to admit superheated steam to the desuperheater. Steam will begin to flow through the desuperheater. The PRV (if fitted) will begin to modulate to control the downstream pressure and the cooling water control valve will begin to open.
5. At this point the desuperheater is fully operational. Operational checks should be made to ensure:-
 - The cooling water valve is modulating correctly.
 - The PRV (if fitted) is modulating correctly.
 - The control valves are neither fully open nor nearly shut. (This would indicate incorrect sizing of these items).
 - The pressures of all streams around the desuperheater are correct.
 - The desired desuperheated temperature is being met.
 - All other ancillary items related to the desuperheater operation are functioning satisfactorily.

6.4 Shutdown procedure

This procedure must be reviewed and checked for consistency of operation with the rest of the plant. The sequence of steps may be revised if necessary, but the general principle of isolating the cooling water as the last step must be followed.

1. Slowly close the upstream steam isolation valve.
2. Close the isolation valve downstream the desuperheater.
3. Close the cooling water isolation valve.
4. De-activate the control system.

The desuperheater is now shut down.

7. Maintenance

Note: Please read Section 1, 'Safety information' before proceeding with any maintenance.

Maintenance should only be carried out by qualified, experienced personnel, who are familiar with desuperheaters and who have read and understood all the instructions in this document.

Caution

Do not proceed with any maintenance unless the spray type desuperheater has:-

- i) Been relieved of all pressure and/or vacuum.
- ii) Been allowed to reach ambient temperatures.
- iii) Been drained and purged of all fluids.
- iv) Had all connecting lines fully isolated.

7.1 Preventative maintenance

Spirax Sarco suggest that the user creates maintenance schedules, safety manuals and inspection schedules for each specific desuperheater installation.

On all installations, the following items should be considered by the user :-

- a) Desuperheater for blockages, particularly the steam nozzle, internal diffuser and cooling water holes. Check cooling water holes for scale build up which could indicate poor cooling water quality.
- b) Desuperheater for internal wear, particularly the steam nozzle, internal diffuser, main diffuser and cooling water holes.
- c) Discharge piping and fittings to be checked for signs of erosion, corrosion, debris build up and blockages.
- d) Sufficient tightness of flange connecting bolts.
- e) Strainers for debris build up.
- f) All other associated ancillary equipment and valves, in particular:-
 - The correct operation of all control equipment.
 - The correct operation of instrumentation.

7.2 Maintenance of Venturi Type desuperheaters

VTD disassembly

We recommend that any personnel carrying out maintenance work are in possession of the General Arrangement drawing of the desuperheater.

For the purposes of:-

- a) Internal Inspection
- b) The fitting of new gaskets.
- c) Removing or fitting a new steam nozzle.
- d) Removing or fitting a new internal diffuser,

the Venturi Type desuperheater must be dis-assembled to some degree.

- 1) Disconnect the connecting flanges to the desuperheater.
- 2) Remove the desuperheater from the line. This immediately permits an internal inspection of the desuperheater but it does not permit a full detailed inspection of the internals.
- 3) With the internals removal tool, enter the steam inlet of the desuperheater and engage the slots in the nozzle. Rotate anti-clockwise to unscrew and remove the nozzle. This will permit full inspection of the nozzle and its associated sealing gaskets.
- 4) With the internals removal tool, enter the discharge connection of the desuperheater and engage the slots in the internal diffuser. Rotate anti-clockwise to unscrew and remove the internal diffuser. This will permit full inspection of the internal diffuser, including the water holes and the associated sealing gaskets.

At this point the desuperheater is completely disassembled.

Re-assembly of the desuperheater is achieved by following the reverse procedure. However, when re-assembling:-

- a) Check all sealing faces are clean, flat and undamaged in anyway. Any damaged sealing faces, whether on the internal housing or internals, must be repaired.
- b) Renew all gaskets within the unit. It is essential for satisfactory operation that the thickness of these gaskets is the same as the ones originally present.
- c) Ensure against over tightening of any component.

8. Troubleshooting

Note: Please read Section 1, 'Safety information' before troubleshooting.

8.1 Introduction

Once successfully commissioned, desuperheaters provide trouble free service. However, as with any equipment in erosive or corrosive service, break down beyond control may occur.

Knowledge of the correct procedures for locating and correcting faults can lead to considerable time saving.

Poor performance of a desuperheater can be caused by either external or internal factors. Secondly, all performance can also be classified as either being gradual or sudden.

In general, a gradual loss of performance will normally suggest internal corrosion or erosion, whereas a sudden loss in performance will normally suggest an external factor is to blame.

Before setting out to examine why the desuperheater is not performing correctly, we strongly recommend that all instruments and any control systems are first checked that they are not giving false readings.

8.2 External causes of poor performance

At this stage, if an actual control system is fitted, ensure that all pressure and temperature indicating controllers are functioning and set correctly. Also check supply and signal pneumatic or electrical lines to the respective actuated control valve. Then check the operation of both the pressure and temperature control valves.

i.) Outlet pressure not in accordance with the specification.

- a) Check the operation of the actuated or manually operated pressure control valve, prior to the desuperheater.
- b) Check the steam pressure upstream and downstream of the pressure control valve.
The superheated steam at the inlet to the desuperheater must be in accordance with the design specification or the design of the unit must be modified.
- c) A varying steam pressure will cause a fluctuating outlet steam pressure unless an actuated pressure control system is fitted.

ii.) Steam outlet temperature not in accordance with the specification.

- a) Check temperature and pressure of cooling water prior to unit is in accordance with the design specification. If the pressure and temperature cannot be changed in accordance with the design specification, the desuperheater must be modified.
- b) Check all ancillary equipment associated with the cooling water supply line, including possible booster pumps, strainers, non - return valves and manually operated and actuated temperature control valves and associated control system.

8.3 Internal causes of poor performance

This involves an investigation into the individual desuperheater.

To perform a full investigation on an individual desuperheater, we recommend that it is removed from its location in the pipeline and then disassembled as described in Section 7.2 of this Manual.

Things to be checked during disassembly are as follows:-

- 1) Eroded and corroded parts, particularly the steam nozzle and the internal diffuser, including the water holes. If the internal components are worn or corroded, spares should be fitted.
- 2) Gaskets and gasket seating surfaces.
Check that gaskets are sitting correctly and do not permit by passing of steam or cooling water. New gaskets should always be fitted when re-assembling a desuperheater (See Section 7.3).
- 3) Blockages or partial blockages, particularly the small water holes in the internal diffuser.
- 4) Concentricity between inlet steam nozzle and internal diffuser/ combined cooling water Mixing Section.
- 5) Cracked components.

VTD Venturi Type desuperheater

