

USTS II

Universal Steam Trap Station

Installation and Maintenance Instructions

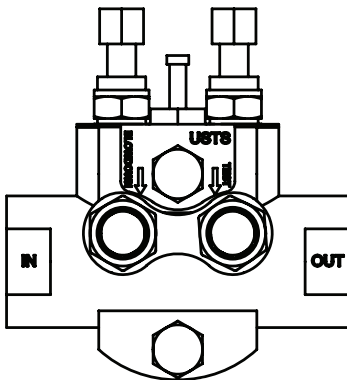

1. Description
2. Installation and start-up
3. Trap station operation
4. Station valve operating positions
5. Maintenance of trap station
6. Rebuilding station inlet and outlet flow valve assemblies
7. Replacing blowdown valve
8. Spare parts

1. Description

The USTS Steam Trap Station is designed to have inlet and outlet isolation valves, integral strainer with blowdown and test valve. Designed as a complete steam main drip or tracer steam trap station, the USTS will support all of the Spirax Sarco universal steam traps.

Limiting operating conditions

PMO	Maximum operating pressure	650 psi g	(45 bar g)
TMO	Maximum operating temperature	750 °F	(399 °C)
PMA		650 psig	(45 bar g)

Note: Maximum operating pressure is determined by the Pressure Shell Design conditions.

Note : Station cannot be operated higher than the steam trap rating

2. Installation and start-up

Before starting any work, make sure all steam is turned off where work is to be performed and is cool. The trap station must be installed in a horizontal pipeline with the valve adjusting screws in an upward position. The strainer blowdown valve and test valve will be perpendicular to the station piping with flow directly vertical down. The NPT piping connections should use a good quality pipe dope to insure a good tight seal (Do not over tighten the NPT piping). Mount selected trap to the connector in the orientation shown on the trap IMI with cap screws supplied with the connector. (Cap screws, which come with the steam trap, are too short). Use the cap screws, which come with the station. Tighten the cap screws to the proper torque as noted on the trap IMI. When the station is completely mounted into the piping and the trap has been mounted properly to the station start-up procedure can begin.

On initial start-up turn the strainer blowdown valve (3) and the test valve (4) to the open position.

Open inlet isolation valve (1) and purge the station.

Close the strainer blowdown valve (3).

Open the outlet isolation valve (2) and close the test valve (4).

Trap station is now in operation.

Observe trap function and check for leaks.

Left hand

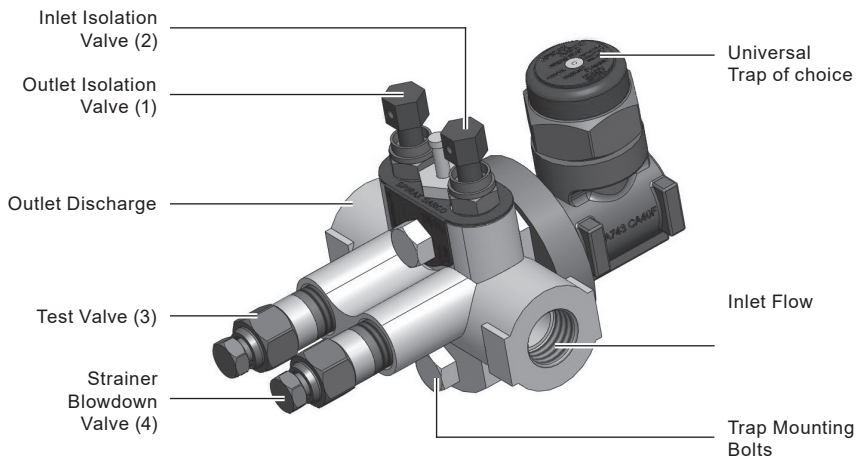

Right hand

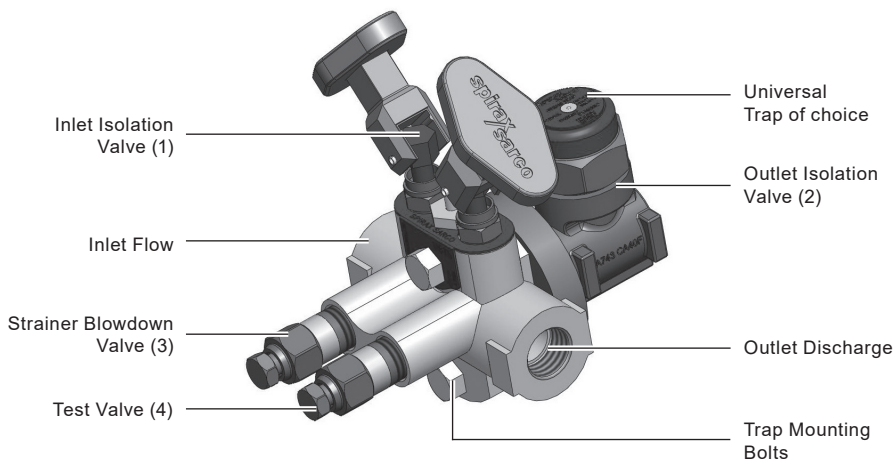

USTS II Universal Steam Trap Station

3. Trap station operation

The station when in normal operation has two valves in the open position (counter clockwise rotation), strainer valve closed (clockwise rotation) and test valve closed (clockwise rotation). All valves can be operated with a 1/2" socket, open -end, box, or adjustable wrench. Valves close off with little force and should not be excessively over tightened.

To test trap with normal flow through trap turn test valve open and close outlet flow valve. Observe the discharge

from the trap. If load is very high and discharge flow is continuous, opening strainer blowdown will reduce flow to the trap so the trap should either close or throttle back if working properly. If the trap is working properly return valve outlet flow valve to open position and close test valve. If trap is malfunctioning go through station isolation for trap maintenance or replacement. Never remove trap until all pressure is released and trap is somewhat cooled.

4. Station valve operating positions

Valve position	Right hand				Left hand			
	1	2	3	4	1	2	3	4
Start-up	O	O	O	C	O	O	C	O
Normal operation	O	O	C	C	O	O	C	C
Trap test	O	C	CO	O	C	O	O	CO
Trap change out	C	C	O	O	C	C	O	O
Strainer blowdown	O	O	O	C	O	O	C	O

O = Open

C = Closed

CO = Cracked open

Note: All valves are open when turned in counter clockwise rotation and closed when turned in clockwise rotation.

(1) Isolation Valve
Inlet - RH
Outlet - LH
(CW to close)

If packing leaks,
turn packing nut 1/8
intervals until leak
stops

2) Isolation Valve
Outlet - RH
Inlet - LH
(CW to close)

Tighten bolt into
trap at 22-26 ft-lbs

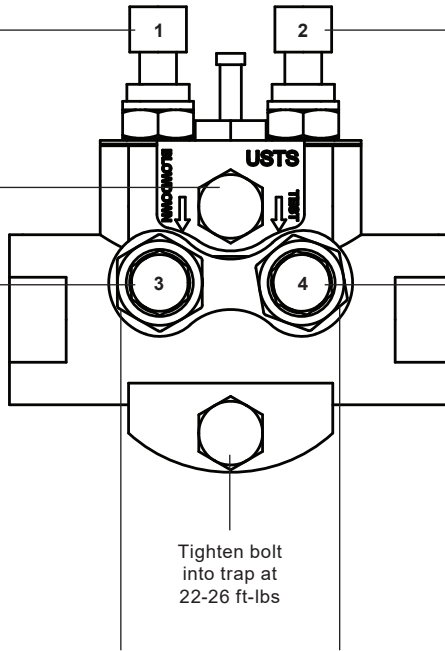

(3) Blowdown Valve
Strainer - RH
Test - LH
(CCW to open)

(4) Blowdown Valve
Test - RH
Strainer - LH
(CCW to open)

Tighten bolt
into trap at
22-26 ft-lbs

Blowdown discharge straight vertical down

All valves use 1/2" socket, box, open-end or adjustable wrench

To clean strainer, open strainer blowdown and allow it to flow for several seconds to clear debris.

Close blowdown valve.

To isolate station, turn inlet and outlet valves to the off position.

Open strainer blowdown and test valve.

Station will be completely depressurized and safe to remove the steam trap.

Note :

**Do not use excessive force to close valves off tight.
Excessive force can damage valves.**

USTS II Universal Steam Trap Station

spirax
sarco

5. Maintenance of trap station

The steam trap station generally does not require maintenance unless the valve leaks some steam along the valve stem. The hex nut is a packing nut and should be treated as such.

Never over tighten these nuts. This packing nut is factory tighten to give a tight seal, and should need no further adjustment under normal conditions,

If a little leakage should develop, the nut can be tightened to stop leakage. Tightened only one flat at a time before inspecting for stopped leakage. The packing should never be tightened more than enough to cause a handle operating torque of 15 ft. lbs.

6. Rebuilding station inlet and outlet flow valve assemblies

The valve assemblies can be replaced in-line by using the following technique:

- a) Remove all process pressure from valve to be serviced in accordance to all in-plant safety requirements.
- b) Open valve fully.
- c) Using a needle nose pliers, grab locking nut stem under the pin locknut stop and tap under pliers to remove pin and nut from station casting.
- d) Loosen packing nut with a $\frac{5}{8}$ " open end wrench.
- e) Screw packing nut up until it hits the hex. Continue to thread it out. If it doesn't pull free move side to side while applying upward force.
- f) Clean internal areas of all debris.
- g) Install new valve sub assembly.*
- h) Tighten packing nut to 100 inch pounds. Align nut flats so lock nut slides between packing nut flats.
- i) Slide locking nut on to pin. Take pin and locking nut assembly and tap into hole between isolation valves on station casting. Slide locking nut between packing nut flats.
- j) Put the valve back in service. Check for leaks and if necessary tighten packing up as above just enough to stop leakage.

* Valve assembly sold as a spare part, consult factory.

7. Replacing blowdown valve

The complete blowdown can be replaced if the unit fails

- a) Remove all process pressure by closing both inlet and out isolation valves on the station. Open both blowdown valves fully to allow all pressure to exhaust off.
- b) Remove the blowdown valve with a adjustable or open end wrench turning it counter clockwise to remove the valve from the trap station.
- c) Using a good pipe thread compound screw the new valve into the trap station (If the blowdown valve has the strainer screen contained within it make sure the screen is lined up in place before beginning to tighten the blow down valve). Tighten with usual force for a 3/8" NPT thread to get a seal making sure the outlet discharge hole is pointing straight down.
- d) Open both blowdown valves.
- e) Open isolation valve and allow the station to blow any dirt through the blowdown.
- f) Close both blowdown valves and inspect station for any leakage.

8. Spare parts

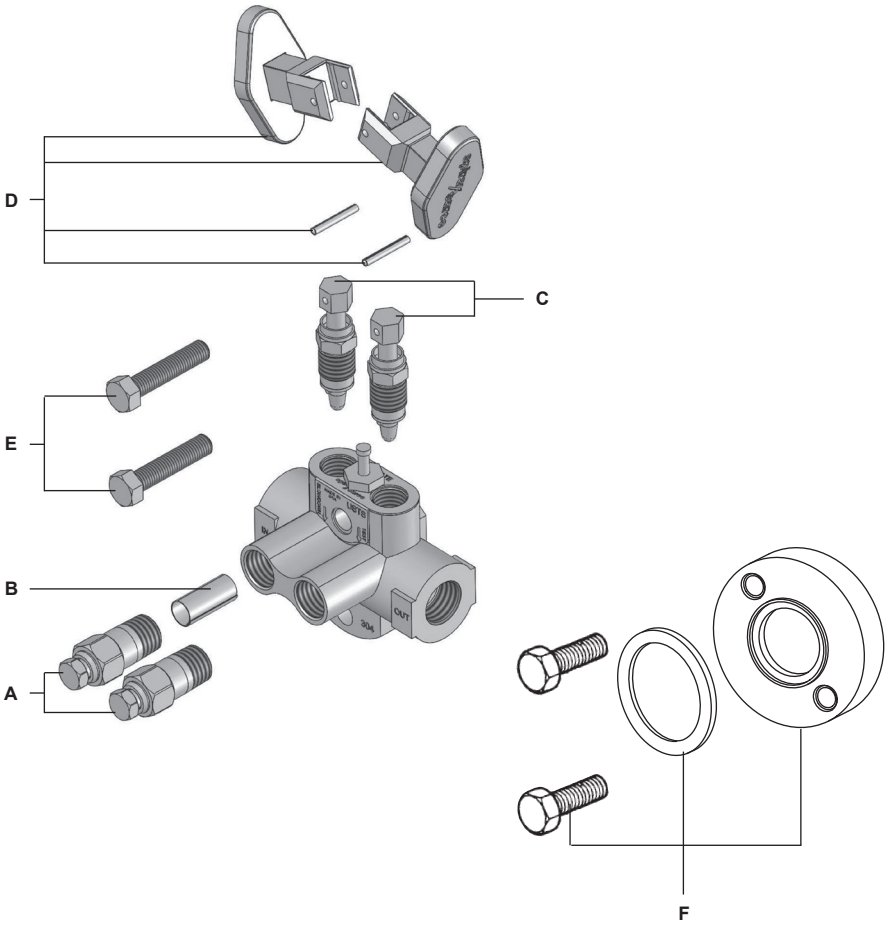

A	Blowdown Valve Assembly	(2 required for complete station)
B	Strainer Screen	(1 required)
C	Valve Assembly (isolation)	(2 required for complete station)
D	Handles with pins	
E	Mounting bolts	(2 required)
F	Blind flange kit	