

# Type 25BP and 26BP Back Pressure Control Valve Type 25P-BP, 25T-BP, 26P-BP and 26T-BP Combination Regulators Installation and Maintenance Instructions

---

---

## 1. Safety information

Safe operation of these products can only be guaranteed if they are properly installed, commissioned, used and maintained by qualified personnel (see Section 1.11) in compliance with the operating instructions. General installation and safety instructions for pipeline and plant construction, as well as the proper use of tools and safety equipment must also be complied with.

### 1.1 Intended use

Referring to the Installation and Maintenance Instructions, name-plate and Technical Information Sheet, check that the product is suitable for the intended use / application.

- i) The products have been specifically designed for use on steam, air or water/condensate. The products' use on other fluids may be possible but, if this is contemplated, Spirax Sarco should be contacted to confirm the suitability of the product for the application being considered.
- ii) Check material suitability, pressure and temperature and their maximum and minimum values. If the maximum operating limits of the product are lower than those of the system in which it is being fitted, or if malfunction of the product could result in a dangerous overpressure or overtemperature occurrence, ensure a safety device is included in the system to prevent such over-limit situations.
- iii) Determine the correct installation situation and direction of fluid flow.
- iv) Spirax Sarco products are not intended to withstand external stresses that may be induced by any system to which they are fitted. It is the responsibility of the installer to consider these stresses and take adequate precautions to minimise them.
- v) Remove protection covers from all connections and protective film from all name-plates, where appropriate, before installation on steam or other high temperature applications.

### 1.2 Access

Ensure safe access and if necessary a safe working platform (suitably guarded) before attempting to work on the product. Arrange suitable lifting gear if required.

### **1.3 Lighting**

Ensure adequate lighting, particularly where detailed or intricate work is required.

### **1.4 Hazardous liquids or gases in the pipeline**

Consider what is in the pipeline or what may have been in the pipeline at some previous time. Consider: flammable materials, substances hazardous to health, extremes of temperature.

### **1.5 Hazardous environment around the product**

Consider: explosion risk areas, lack of oxygen (e.g. tanks, pits), dangerous gases, extremes of temperature, hot surfaces, fire hazard (e.g. during welding), excessive noise, moving machinery.

### **1.6 The system**

Consider the effect on the complete system of the work proposed. Will any proposed action (e.g. closing isolation valves, electrical isolation) put any other part of the system or any personnel at risk?

Dangers might include isolation of vents or protective devices or the rendering ineffective of controls or alarms. Ensure isolation valves are turned on and off in a gradual way to avoid system shocks.

### **1.7 Pressure systems**

Ensure that any pressure is isolated and safely vented to atmospheric pressure. Consider double isolation (double block and bleed) and the locking or labelling of closed valves. Do not assume that the system has depressurised even when the pressure gauge indicates zero.

### **1.8 Temperature**

Allow time for temperature to normalise after isolation to avoid danger of burns.

### **1.9 Tools and consumables**

Before starting work ensure that you have suitable tools and / or consumables available. Use only genuine Spirax Sarco replacement parts.

### **1.10 Protective clothing**

Consider whether you and / or others in the vicinity require any protective clothing to protect against the hazards of, for example, chemicals, high / low temperature, radiation, noise, falling objects, and dangers to eyes and face.

### **1.11 Permits to work**

All work must be carried out or be supervised by a suitably competent person. Installation and operating personnel should be trained in the correct use of the product according to the Installation and Maintenance Instructions.

Where a formal 'permit to work' system is in force it must be complied with. Where there is no such system, it is recommended that a responsible person should know what work is going on and, where necessary, arrange to have an assistant whose primary responsibility is safety.

Post 'warning notices' if necessary.

## 1.12 Handling

Manual handling of large and/or heavy products may present a risk of injury. Lifting, pushing, pulling, carrying or supporting a load by bodily force can cause injury particularly to the back. You are advised to assess the risks taking into account the task, the individual, the load and the working environment and use the appropriate handling method depending on the circumstances of the work being done.

## 1.13 Residual hazards

In normal use the external surface of the product may be very hot. If used at the maximum permitted operating conditions the surface temperature of some products may reach temperatures in excess of 300 °C (572 °F).

Many products are not self-draining. Take due care when dismantling or removing the product from an installation (refer to 'Maintenance instructions').

## 1.14 Freezing

Provision must be made to protect products which are not self-draining against frost damage in environments where they may be exposed to temperatures below freezing point.

## 1.15 Disposal

Unless otherwise stated in the Installation and Maintenance Instructions, this product is recyclable and no ecological hazard is anticipated with its disposal providing due care is taken.

## 1.16 Returning products

Customers and stockists are reminded that under EC Health, Safety and Environment Law, when returning products to Spirax Sarco they must provide information on any hazards and the precautions to be taken due to contamination residues or mechanical damage which may present a health, safety or environmental risk. This information must be provided in writing including Health and Safety data sheets relating to any substances identified as hazardous or potentially hazardous.

## 1.17 Working safely with cast iron products on steam

Cast iron products are commonly found on steam and condensate systems. If installed correctly using good steam engineering practices, it is perfectly safe. However, because of its mechanical properties, it is less forgiving compared to other materials such as SG iron or carbon steel. The following are the good engineering practices required to prevent waterhammer and ensure safe working conditions on a steam system.

### Safe Handling

Cast Iron is a brittle material. If the product is dropped during installation and there is any risk of damage the product should not be used unless it

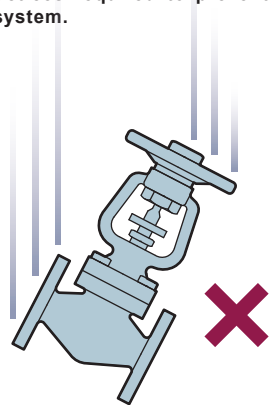

---

Type 25BP and 26BP Back Pressure Control Valve / Type 25P-BP, 25T-BP, 26P-BP and 26T-BP Combination Regulators

# Prevention of waterhammer

Steam trapping on steam mains:

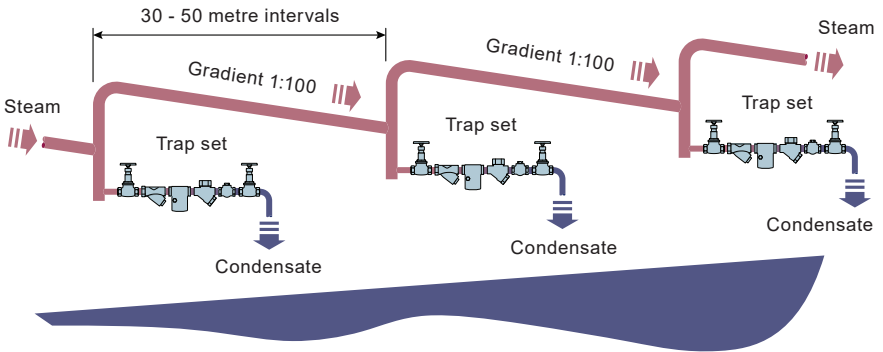

## Steam Mains - Do's and Don'ts:

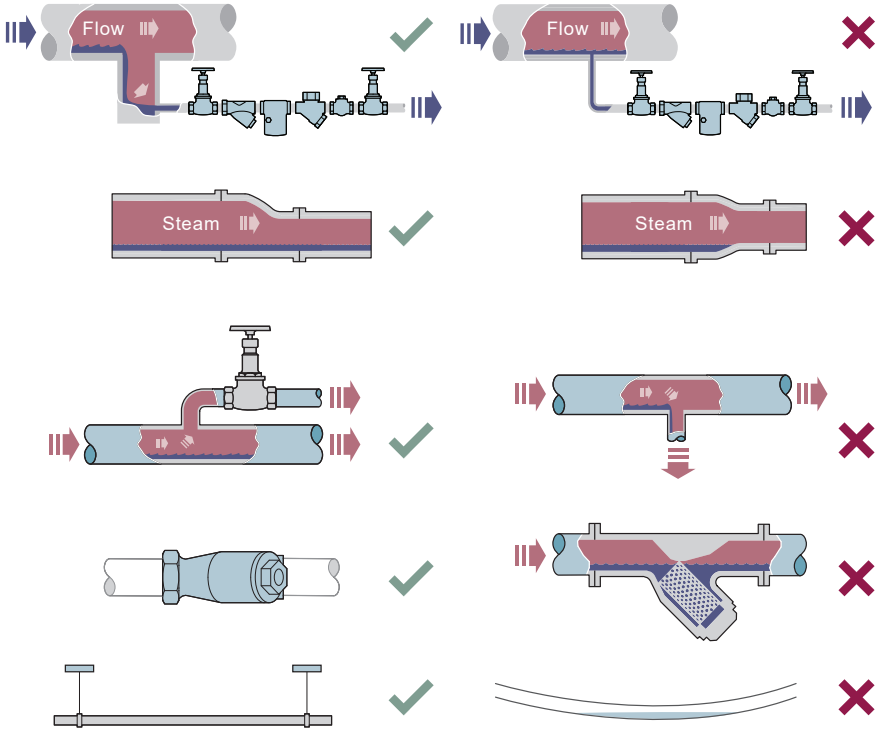

## Prevention of tensile stressing

Pipe misalignment:

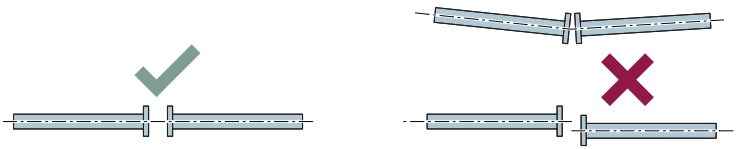

Installing products or re-assembling after maintenance:



Do not over tighten.  
Use correct torque figures.

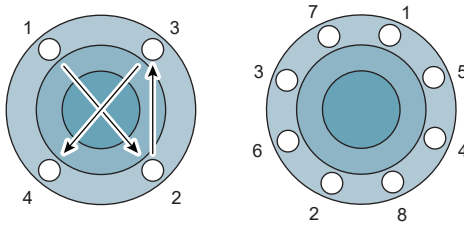

Flange bolts should be gradually tightened across diameters to ensure even load and alignment.

Prevention of tensile stressing continued on next page

**Thermal expansion:**

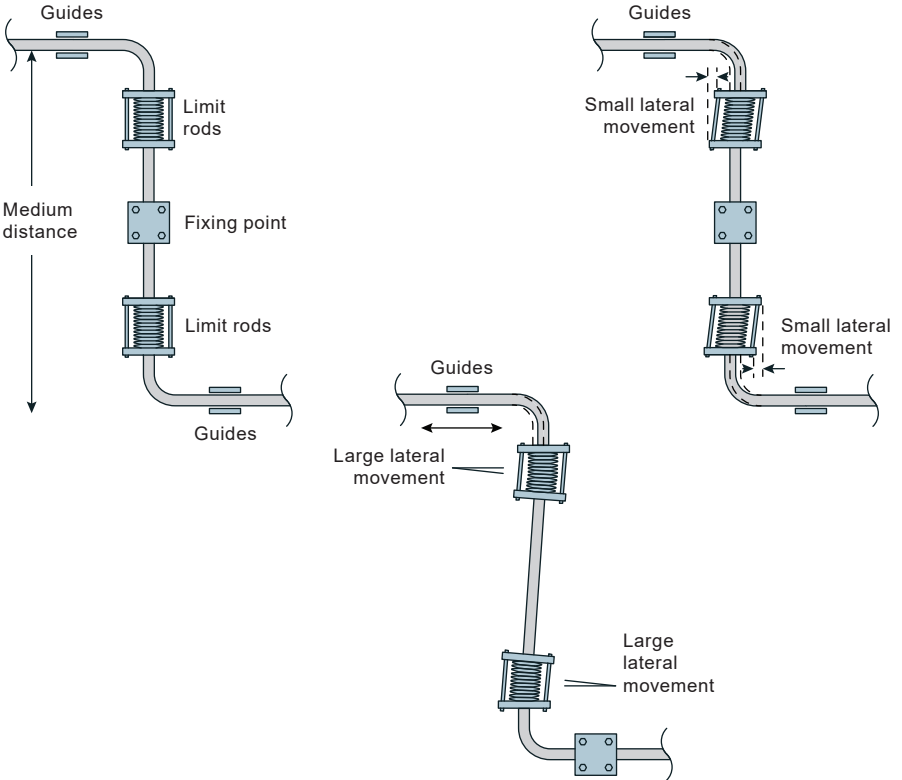
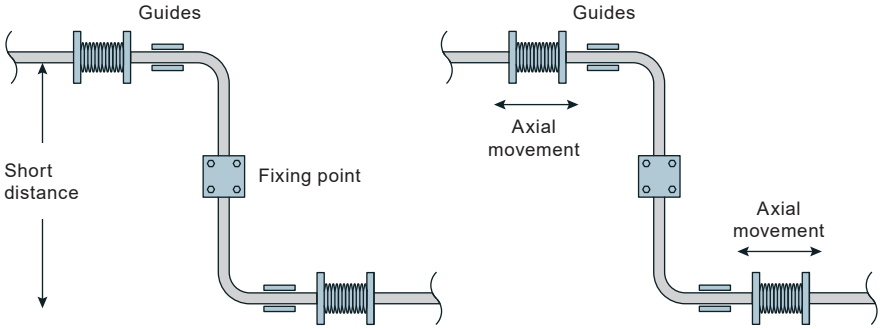

## 2. General product information

The Type 25BP is a back pressure regulator for steam service. The control consists of a pilot with reverse-acting valve trim that positions a main valve in response to pressure fluctuations at the inlet. Normal operation of the main valve will depend on the application type:

**Type A. As a back pressure surplussing valve**

The normally closed main valve is opened by the pilot when the inlet pressure increases above its setting. (Figure 2)

**Type B. For automatic shedding of non-essential steam loads when peak demand causes line pressure to fall.**

The main valve is normally open and is closed by the pilot when inlet pressure drops below the set point. (Figure 3)

**Type C. Using a combination of back pressure pilot with either temperature or pressure control to automatically shed non-essential steam loads when peak demand causes line pressure to fall.**

The valve will shut steam off to a piece of steam-consuming equipment that is under either pressure or temperature control when inlet pressure drops below setting of back pressure pilot. (Figure 4)

### How the 25BP operates

Normal positions before start-up are with the main valve closed and the pilot valve held closed by spring force. The pressure on the inlet side of the valve acts on the bottom of the pilot valve diaphragm through the sensing line to oppose the force of the pilot valve spring. As this force increases beyond the thrust of the spring, the pilot valve is opened. This sends pressure from the inlet side of the valve to the bottom of the main valve diaphragm thereby forcing the main valve head open. Simultaneously, the pressure in the main valve diaphragm is controlled by the opening of the pilot valve head and by the bleed orifice. The net result is that the pilot valve positions itself to maintain a predetermined main valve opening to insure a constant pressure on the inlet side of the valve. Any increase in the inlet pressure opens the valve further and any decrease in pressure tends to close the valve. When the inlet pressure to the valve falls below the setting of the pilot valve, the main valve closes tight to provide a dead-end shutoff. Adjustment of the spring above the pilot diaphragm changes the inlet pressure set point. This valve, in effect, operates as a safety valve. The difference is that the back pressure regulator throttles flow whereas the safety valve pops full open.

**Fig. 1**  
**Type 25BP Back Pressure Regulator**

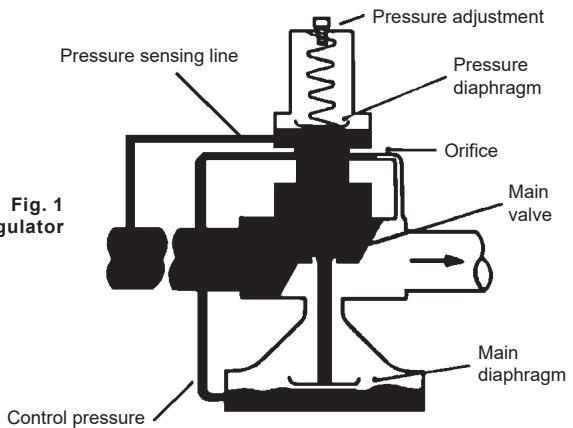

# 3. Installation

## Installing the valve

### Unpack carefully

Do not lift the regulator by the tubing. Grasp the body of the valve firmly when lifting.

### Caution:

Installation and troubleshooting should be performed by qualified service personnel. Before breaking any connection every effort should be made to assure that internal pressure has been relieved. When breaking any connection, piping/bolts should be removed slowly so that if the line is under pressure, this fact will be apparent before completely removing the pipe or component. Always relieve pressure before breaking any joint.

### Piping

1. Typical hookup sketches as shown in Figures 2, 3 and 4 will aid in planning a correct installation.
2. Piping on the downstream side of the valve should be increased so as not to restrict flow.
3. Swage nipples are recommended for changes in pipe sizes and a Spirax Sarco ½" steam trap fitted to drain any condensate from the valve inlet.
4. Before installing the valve, make sure the piping is free of foreign material, scale, etc. A pipeline strainer is recommended before the valve and all steam traps.
5. Make certain the arrow cast on valve body is pointing in the direction of flow.
6. Valve should always be installed in a horizontal position.
7. Pressure gauges must be installed on both sides of reducing valve.

### Pilot pressure sensing line for back pressure pilot

1. Copper tubing (¼" OD) can be used for the sensing line with suitable compression fittings or as an alternative, ¼" piping can be used.
2. Connect the sensing line to the upstream side of the main valve to a straight portion of the piping 10 pipe diameters from nearest fitting and approximately 1 foot from elbows, tees, valves and other restrictions. (See Figures 2, 3 and 4).
3. Install a small gate valve in the sensing line so that this can be closed when servicing the regulator.
4. The sensing line must be pitched downward from the main valve to ensure proper drainage.
5. To permit accurate setting of the back pressure regulator, a pressure gauge should be installed as close as possible to the pilot sensing line connection.

**Note:** Installation of sensing line for Pressure Reducing Pilot is identical, except that it is connected to the down-stream steam line.





# 4. Applications

## Type A application

### Surplussing valve for upstream pressure controls

A typical flash recovery system hookup is shown in Figure 2. This application allows utilizing flash steam whose pressure is limited by the 25BP (back pressure valve) for low pressure processing. The 25BP acts as a surplussing valve venting only excess steam from the receiver to atmosphere.

#### Note:

The 25BP control setting (receiver maximum operating pressure) may be greater than that normally desired in the Low Pressure main but must not exceed the pressure rating of the L.P. equipment being supplied. Also, it is recommended that the setting should not exceed 50% of the high pressure system steam traps. This is most important when H.P. equipment is supplied by modulating control valves.

The Back Pressure control setting should also be at least 2 to 5 psi g below the Safety Relief Valve pressure setting. These recommendations allow maximum recovery of flash steam and will prevent excessive back pressure from interfering with operation of the H.P. system traps and equipment.

### Pilot setting procedure:

1. On existing installations, make certain flash tank is isolated from low pressure steam and condensate return piping.
2. Make certain that a safety valve, in good operating condition, is installed and is properly set to protect the flash tank. **A back pressure regulator is NOT a safety valve and should NEVER be used for the purpose.**
3. Provisions must be made for proper trapping of condensate from the flash tank.
4. After installing 25BP regulator with sensing line back to inlet, remove stainless steel cover from pilot, exposing the adjusting spring.
5. **To set the valve opening pressure:** Turning the adjusting spring screw **clockwise will increase** the pressure at which the 25BP control will open. Turning counterclockwise will reduce the set pressure.
6. Turn 25BP pilot adjustment screw clockwise approximately 5 turns. This is to make sure that the BP pilot is in a closed position.
7. The high pressure condensate system can now be put into operation; however, steam valve A to low pressure system must be kept closed.
8. As steam pressure develops in flash vessel, observe pressure on Gauge B. When the desired pressure is obtained, turn adjustment screw on 25BP pilot counterclockwise until main valve just starts to open. This opening point can be determined by audible means or observing flow at exit of vent pipe.
9. After setting has been established, Valve A to low pressure main can be opened. Replace cover over pilot spring and tighten lock nut on adjustment stem to secure the setting. Valve is now in operation.

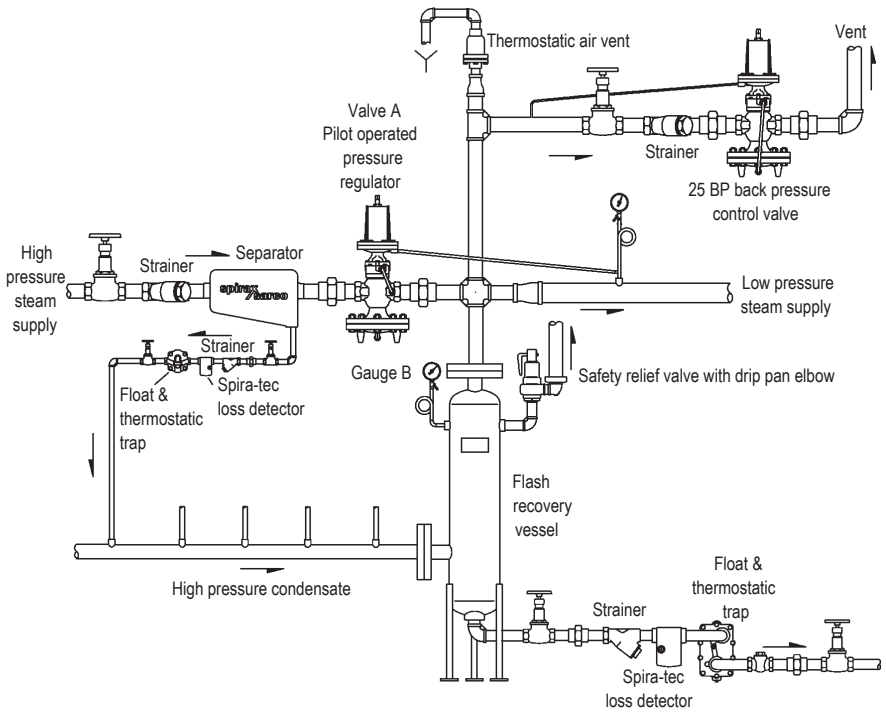

**Fig. 2**  
**25 BP back pressure control as a surplussing valve venting excess flash steam to atmosphere.**

## Type B Application

### Automatic shutdown of steam supply to non-critical loads.

A typical hookup is shown on Figure 3. This application automatically shuts off steam supply to non-critical loads at peak load times when boiler capacity is not sufficient to supply steam to essential requirements. When boiler capacity is available and inlet pressure rises, the 25BP regulator will again open and automatically supply steam to non-critical loads.

### Pilot Setting Procedure:

When making setting adjustments, load demand on valve should not be less than 10% and not greater than 90% of the valve rated capacity.

1. Check that 25BP regulator is installed with sensing line connected back to the inlet and make certain ALL stop valves are closed (Figure 3, #2 through #5).
2. Remove 25BP pilot spring cover from pilot, exposing the adjustment spring.
3. When adjusting pressure setting: Increasing spring tension by turning the adjustment screw clockwise will increase the shutdown pressure. Turning counterclockwise will lower the shutoff setting.
4. Turn adjustment screw on 25BP pilot counterclockwise to release all tension on the spring. This is to make sure that the 25BP pilot is fully open. Make certain spring remains in vertical position.
5.
  - a. Make certain valve #1 ahead of steam trap on steam supply line is open. This will ensure water-free steam at the regulator inlet when put into operation.
  - b. Open small gate valve #2 on pressure control line.
  - c. Open downstream stop valve #4. Valve is now set to be fully open when steam is supplied to it.

**Note:** When reduction in steam flow (due to valve beginning to close) can be determined either visually or with a sonic test instrument and shutdown pressure is not critical, the "Quick-Set Method" can be attempted (See Page 16.) All other installations should proceed as follows:

6. Remove the copper tubing located just below the base of the back pressure pilot leading to the downstream side of the valve so that any flow from the 25BP pilot valve can be seen.

**Caution:** During this procedure, beware of possible steam flow from tubing connector if stop valve #3 does not seal completely tight. Steam will flow from open connector during step (7) so stand aside before proceeding.

7. Slowly open inlet stop valve #3 until pressure on Gauge A registers the desired shutdown pressure.
8. Turn adjustment screw on BP pilot clockwise slowly until flow of steam from open connection just about stops (in operation the control will now close).
9. Close inlet stop valve #3. Before proceeding, wait a few minutes while valve cools and inlet steam condenses.
10. Next, carefully reconnect copper tubing to close open connection created in step #6. This will be proper setting of BP pilot to close main valve when inlet pressure drops to the set pressure.
11. Replace spring cover on BP pilot and tighten locknut on adjustment stem to secure the setting.
12. Slowly open inlet stop valve #3 to place regulator in operation

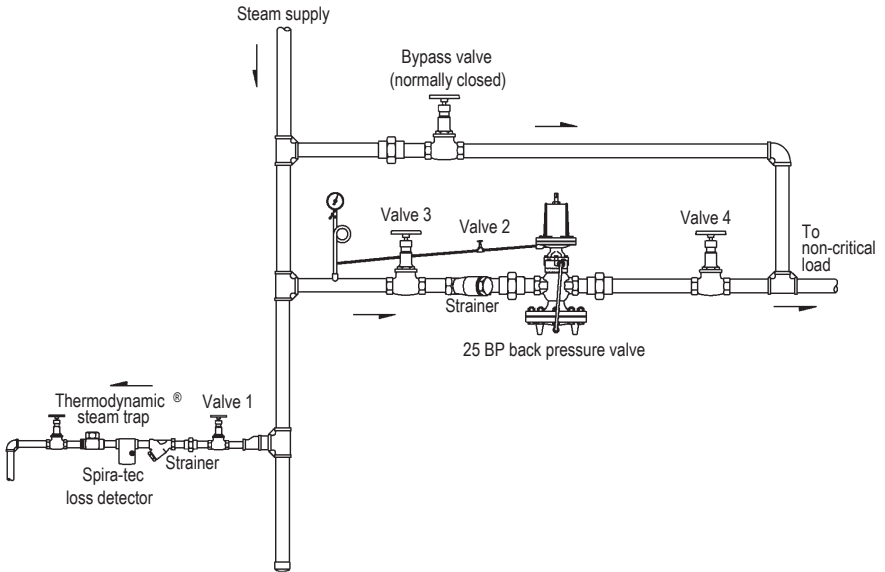

**Fig. 3**  
**25 BP Back Pressure control used to cut off steam to non-essential loads at times of boiler overload.**

## Type C Application

### Automatic shutdown of steam supply to non-critical loads when controlled by combination regulator.

See Figure 4 for typical hookup. This valve, while either controlling the downstream steam pressure to a piece of equipment with a 'P' Pilot or controlling the temperature of a secondary fluid with a 'T' Pilot, will also automatically shut off the steam supply should the incoming steam pressure fall below the setting of the 25BP pilot.

#### Pilot setting procedure:

1. First, make certain all stop valves are closed (2 through 6).
2. Remove back pressure pilot spring cover.
3. Turn adjustment screw on back pressure pilot counterclockwise to release tension on spring. This is to make sure that the 25BP pilot is fully open. Make certain spring remains in vertical position.
4. Remove 'P' pilot spring cover.
5. Turn adjustment on 'P' pilot counterclockwise to release tension. Make certain spring remains in vertical position. Open stop valves in following order:
  - a. Make certain valve #1 ahead of steam trap on steam supply line is open. This will ensure water-free steam at the regulator inlet when put into operation.
  - b. Open small gate valves #2 and #3.
  - c. Open downstream stop valve #5.
  - d. Slowly open inlet stop valve #4.
6. Slowly adjust 'P' pilot spring, turning clockwise, until reduced pressure required is indicated on downstream pressure gauge.
7. Once system has stabilized, re-adjustment of spring setting may be necessary.
8. Close inlet stop valve #4.
9. For setting 'BP' pilot, see pilot setting procedure for Type B Applications.

## Pilot Setting Procedure for 25T-BP

1. First, make certain all stop valves are closed (3 through 6). Valve #2 on Figure 3 is not installed since there is no down- stream sensing line.
  2. Remove 'BP' pilot spring cover.
  3. Turn adjustment screw on 25BP pilot counter- clockwise to release ten- sion on spring. This is to make sure that the 25BP pilot is fully open. Make certain spring remains in vertical position.
  4. Carefully uncoil the flexible tubing, avoiding sharp bends and kinks.
  5. Support flexible tubing to protect it against mechanical damage.
  6. Keep flexible tubing away from hot pipe lines or other hot surfaces.
  7. Install thermostatic bulb to unit to be controlled. Make certain that the entire bulb is exposed to the medium being controlled. Accuracy of regulation depends on the bulb being located in a representative location with adequate circulation over it.
  8. If a separable socket is used for the temperature bulb, it is recommended that the socket be packed with a heat transfer compound to minimize lag in response to temperature changes caused by the insulating air layer between bulb and socket.
  9. Adjust the temperature pilot to the temperatruere required by turning the red adjustment knob. Caution: Do not loosen Allen set-screw in the red temperature knob.
  10. Open stop valves in the following order:
    - a. Open stop valve #1 ahead of steam trap on steam supply line. This will ensure condensate-free steam at the regulator inlet.
    - b. Open downstream stop valve #5.
    - c. Slowly open inlet stop valve #4.
  11. After the system has stabilized itself, check thermom- eter temperature. Re-adjustment of the temperature pilot knob may be necessary.
- Note:** In the event the temperature indicated on the cali- brated dial does not agree with the thermometer, the temperature pilot can be recalibrated to match the thermometer as described in IM-1-1116-US.
12. Close inlet stop valve #4.
  13. For setting of 25BP pilot, see pilot setting procedure for Type B Applications.

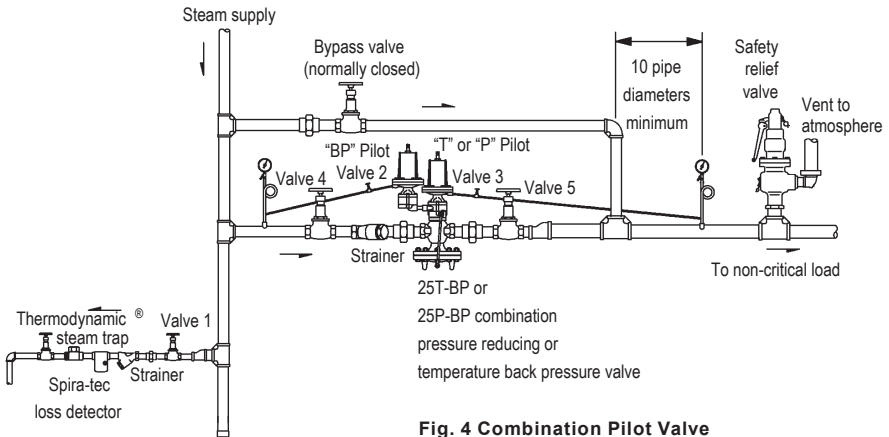

Fig. 4 Combination Pilot Valve

Type 25BP and 26BP Back Pressure Control Valve / Type 25P-BP, 25T-BP, 26P-BP and 26T-BP Combination Regulators

## "Quick-Set" Method

- Follow steps (1) through (5) above for type B application, then slowly open stop valve #3 fully, allowing steam to flow downstream through the 25BP control.
- When flow has stabilized, slowly close valve #3 until the inlet pressure drops to the desired setting, then slowly increase pilot spring tension (by turning adjustment screw clockwise) until the 25BP valve begins to close.
- The inlet pressure will have to be throttled more as the 25BP valve closes and it is usually best to have an assistant control the valve inlet pressure.
- When the correct pilot spring tension has been determined, replace the cover and secure the locknut.
- Fine-tune the setting as necessary after the 25BP control is placed in actual operating conditions.

## Maintenance

Main valve servicing procedures for a Spirax Sarco 25BP Back Pressure control are identical to those of other pressure control valves as given in IM-3-000-US for pressure reducing valves. An exception is the pilot valve head and seat assembly which close when spring tension is applied.

Combination pilot servicing procedures can be found on IM-1-1116-US.

**Spirax Sarco Applications Engineering Department**  
Toll Free at: 1-800-883-4411

**SPIRAX SARCO, INC.**  
1150 NORTHPOINT BLVD.  
BLYTHEWOOD, SC 29016  
PHONE 803-714-2000  
FAX 803-714-2222  
[www.spiraxsarco.com/global/us](http://www.spiraxsarco.com/global/us)