



Type 25P, 25PA, 26P and 26PA Pressure Reducing Valves Installation and Maintenance Instructions

1. Safety information

Safe operation of these products can only be guaranteed if they are properly installed, commissioned, used and maintained by qualified personnel (see Section 1.11) in compliance with the operating instructions. General installation and safety instructions for pipeline and plant construction, as well as the proper use of tools and safety equipment must also be complied with.

1.1 Intended use

Referring to the Installation and Maintenance Instructions, name-plate and Technical Information Sheet, check that the product is suitable for the intended use / application.

- i) The products have been specifically designed for use on steam, air or water/condensate. The products' use on other fluids may be possible but, if this is contemplated, Spirax Sarco should be contacted to confirm the suitability of the product for the application being considered.
- ii) Check material suitability, pressure and temperature and their maximum and minimum values. If the maximum operating limits of the product are lower than those of the system in which it is being fitted, or if malfunction of the product could result in a dangerous overpressure or overtemperature occurrence, ensure a safety device is included in the system to prevent such over-limit situations.
- iii) Determine the correct installation situation and direction of fluid flow.
- iv) Spirax Sarco products are not intended to withstand external stresses that may be induced by any system to which they are fitted. It is the responsibility of the installer to consider these stresses and take adequate precautions to minimise them.
- v) Remove protection covers from all connections and protective film from all name-plates, where appropriate, before installation on steam or other high temperature applications.

1.2 Access

Ensure safe access and if necessary a safe working platform (suitably guarded) before attempting to work on the product. Arrange suitable lifting gear if required.

1.3 Lighting

Ensure adequate lighting, particularly where detailed or intricate work is required.

1.4 Hazardous liquids or gases in the pipeline

Consider what is in the pipeline or what may have been in the pipeline at some previous time. Consider: flammable materials, substances hazardous to health, extremes of temperature.

1.5 Hazardous environment around the product

Consider: explosion risk areas, lack of oxygen (e.g. tanks, pits), dangerous gases, extremes of temperature, hot surfaces, fire hazard (e.g. during welding), excessive noise, moving machinery.

1.6 The system

Consider the effect on the complete system of the work proposed. Will any proposed action (e.g. closing isolation valves, electrical isolation) put any other part of the system or any personnel at risk?

Dangers might include isolation of vents or protective devices or the rendering ineffective of controls or alarms. Ensure isolation valves are turned on and off in a gradual way to avoid system shocks.

1.7 Pressure systems

Ensure that any pressure is isolated and safely vented to atmospheric pressure. Consider double isolation (double block and bleed) and the locking or labelling of closed valves. Do not assume that the system has depressurised even when the pressure gauge indicates zero.

1.8 Temperature

Allow time for temperature to normalise after isolation to avoid danger of burns.

1.9 Tools and consumables

Before starting work ensure that you have suitable tools and / or consumables available. Use only genuine Spirax Sarco replacement parts.

1.10 Protective clothing

Consider whether you and / or others in the vicinity require any protective clothing to protect against the hazards of, for example, chemicals, high / low temperature, radiation, noise, falling objects, and dangers to eyes and face.

1.11 Permits to work

All work must be carried out or be supervised by a suitably competent person. Installation and operating personnel should be trained in the correct use of the product according to the Installation and Maintenance Instructions.

Where a formal 'permit to work' system is in force it must be complied with. Where there is no such system, it is recommended that a responsible person should know what work is going on and, where necessary, arrange to have an assistant whose primary responsibility is safety.

Post 'warning notices' if necessary.

1.12 Handling

Manual handling of large and/or heavy products may present a risk of injury. Lifting, pushing, pulling, carrying or supporting a load by bodily force can cause injury particularly to the back. You are advised to assess the risks taking into account the task, the individual, the load and the working environment and use the appropriate handling method depending on the circumstances of the work being done.

1.13 Residual hazards

In normal use the external surface of the product may be very hot. If used at the maximum permitted operating conditions the surface temperature of some products may reach temperatures in excess of 300 °C (572 °F).

Many products are not self-draining. Take due care when dismantling or removing the product from an installation (refer to 'Maintenance instructions').

1.14 Freezing

Provision must be made to protect products which are not self-draining against frost damage in environments where they may be exposed to temperatures below freezing point.

1.15 Disposal

Unless otherwise stated in the Installation and Maintenance Instructions, this product is recyclable and no ecological hazard is anticipated with its disposal providing due care is taken.

1.16 Returning products

Customers and stockists are reminded that under EC Health, Safety and Environment Law, when returning products to Spirax Sarco they must provide information on any hazards and the precautions to be taken due to contamination residues or mechanical damage which may present a health, safety or environmental risk. This information must be provided in writing including Health and Safety data sheets relating to any substances identified as hazardous or potentially hazardous.

1.17 Working safely with cast iron products on steam

Cast iron products are commonly found on steam and condensate systems. If installed correctly using good steam engineering practices, it is perfectly safe. However, because of its mechanical properties, it is less forgiving compared to other materials such as SG iron or carbon steel. The following are the good engineering practices required to prevent waterhammer and ensure safe working conditions on a steam system.

Safe Handling

Cast Iron is a brittle material. If the product is dropped during installation and there is any risk of damage the product should not be used unless it

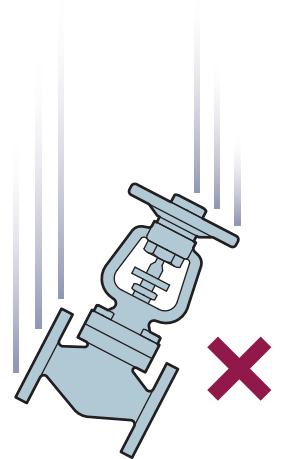

Prevention of waterhammer

Steam trapping on steam mains:

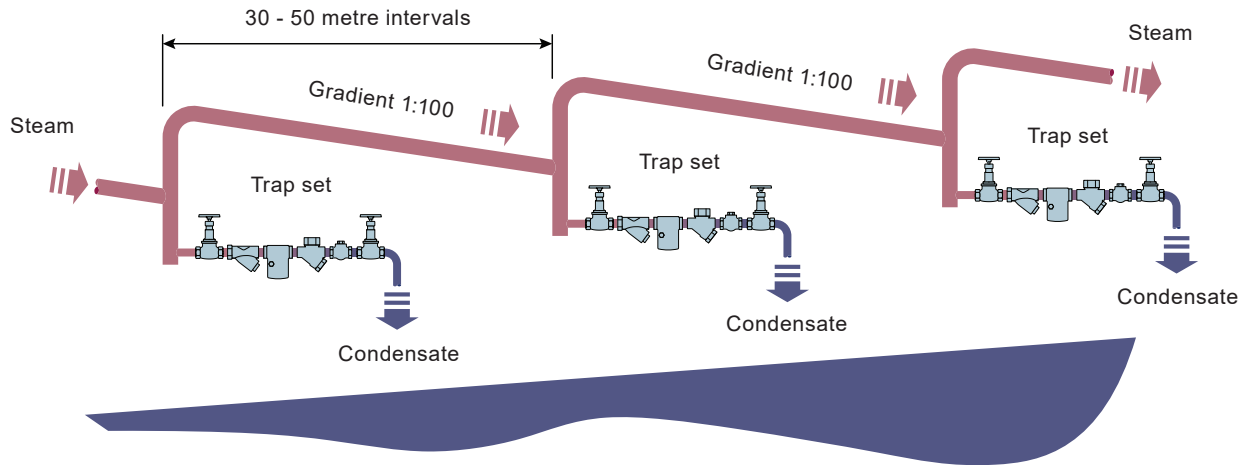

Steam Mains - Do's and Don'ts:

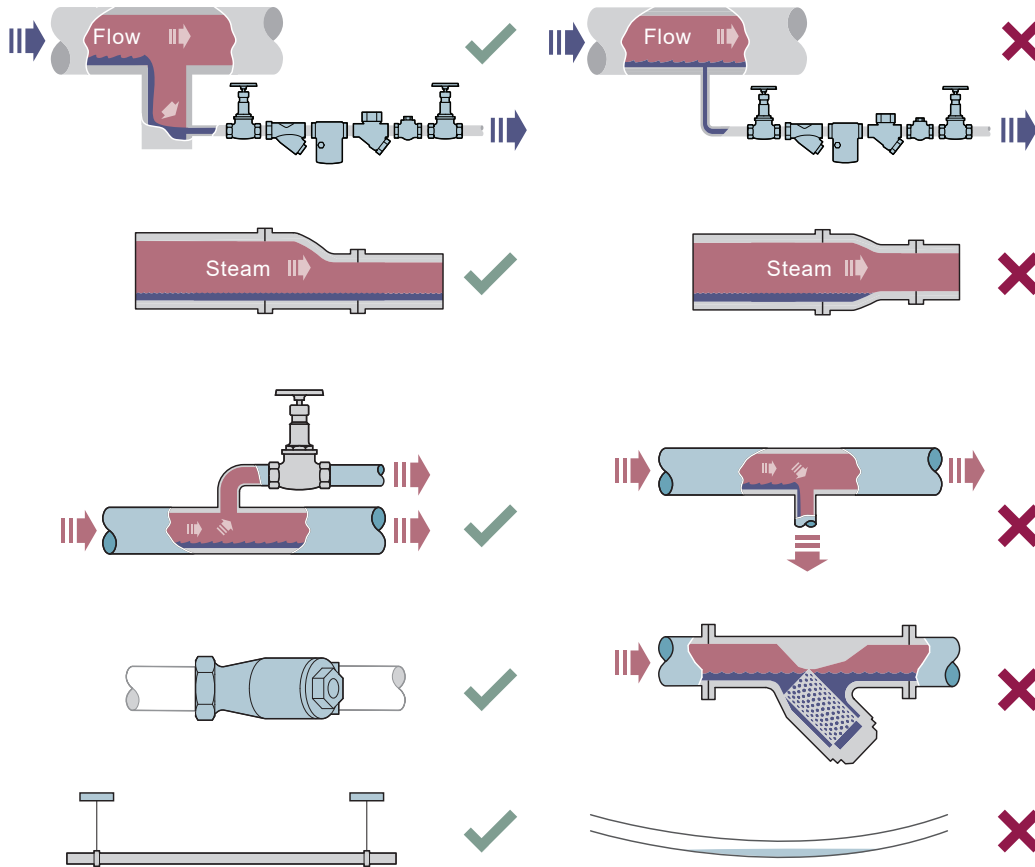

Prevention of tensile stressing

Pipe misalignment:

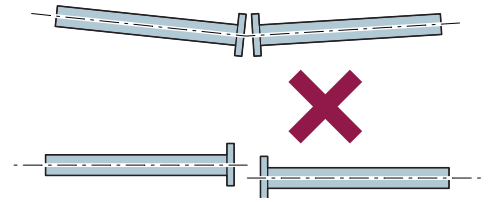
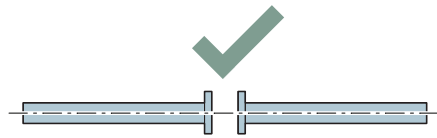

Installing products or re-assembling after maintenance:



Do not over tighten.
Use correct torque figures.

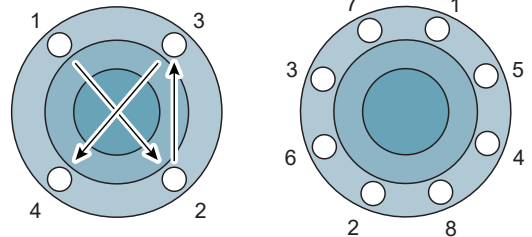

Flange bolts should be gradually tightened across diameters to ensure even load and alignment.

Thermal expansion:

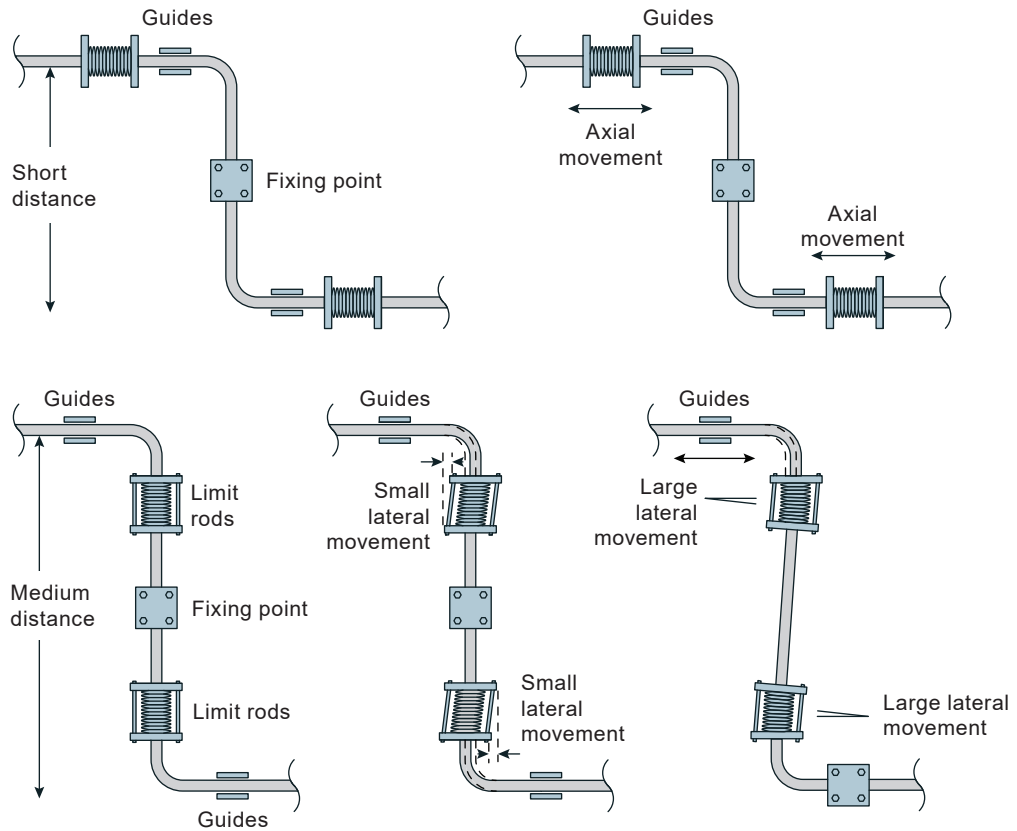

2. Installing the valve

Unpack Carefully

Do not lift the regulator by the tubing. Grasp the body of the valve firmly when lifting.

	<ol style="list-style-type: none">1. Typical hookup sketches as shown in Figs. 1 and 2 will aid in planning a correct installation.2. Piping on the downstream side of the valve should be increased so as not to restrict flow.3. Swage nipples are recommended for changes in pipe sizes.
Piping	<ol style="list-style-type: none">4. Before installing the valve make sure the piping is free of foreign material, scale, etc.5. Make certain the arrow cast on valve body is pointing in the direction of flow.6. Valve should always be installed in a horizontal position. (See Figs. 1 and 2.)7. Pressure Gauges must be installed on both sides of the reducing valve.
Assembling pilot to valve body	<ol style="list-style-type: none">1. Remove all protective caps from ports if present.2. Remove the package of square gaskets from the pilot box and install on the main valve cover assembly (A).3. Install pilot on top of gasket just placed on main valve cover assembly (A) so that the sensing line is pointing in same direction as the valve outlet connection. Be sure that the guide pin in the cover assembly (A) fits securely in the guide hole in the pilot. Be sure the pilot bolts are secured to the valve cover assembly (A) and tightened.
Pilot pressure sensing line	<ol style="list-style-type: none">1. Copper tubing ($\frac{1}{4}$" OD) can be used for the sensing line with suitable compression fittings or as alternative $\frac{1}{4}$" piping can be used.2. Connect the sensing line to a straight portion of the piping 10 pipe diameters from nearest fitting downstream from the valve and approximately 1 foot from elbows, tees, valves and other restrictions. (See Figs. 1 and 2.)3. When the reducing valve is serving a single piece of equipment, the sensing line can be connected to the steam space of the equipment.4. Install a small gate valve in the sensing line so that this can be closed when servicing the regulator.5. The sensing line must be pitched downward from the main valve to insure proper drainage.6. To permit accurate setting of the pressure regulator, a pressure gauge should be installed as close as possible to the pilot sensing line connection.
Bypass	<ol style="list-style-type: none">1. A bypass connection, as shown in Figs. 1 and 2, is recommended so that the valve can be serviced without shutting down the equipment.2. The bypass valve should be the same size as the pressure reducing valve.
Steam line drain trap	<ol style="list-style-type: none">1. To insure proper operation of the valve and avoid premature wear, it is recommended that a $\frac{1}{2}$" Spirax Sarco thermodynamic steam trap be installed on the steam supply line. (See Figs. 1 and 2.)2. A steam trap should also be installed in the downstream piping at the heel of each rise, between all reducing valves installed in series, and ahead of any manual or automatic valve. This will prevent condensate accumulation that can result in waterhammer damage.
Pipeline strainers	<ol style="list-style-type: none">1. It is strongly recommended that strainers be installed before the reducing valve and steam traps.2. Make certain adequate clearance is provided for screen removal and blowdown connection between strainer and valve body.
Stop valves	All stop valves on the supply side, as well as on the downstream side of the pressure reducing valve and sensing line, should be of the gate type so as to insure full rated capacity and good control.
Separators	It is recommended that a line size separator is installed before all pressure reducing stations where the pipeline supply is longer than 50 ft from a trapping station or where exposure or piping configurations lead to the accumulation of significant amounts of condensate ahead of the PRV station.

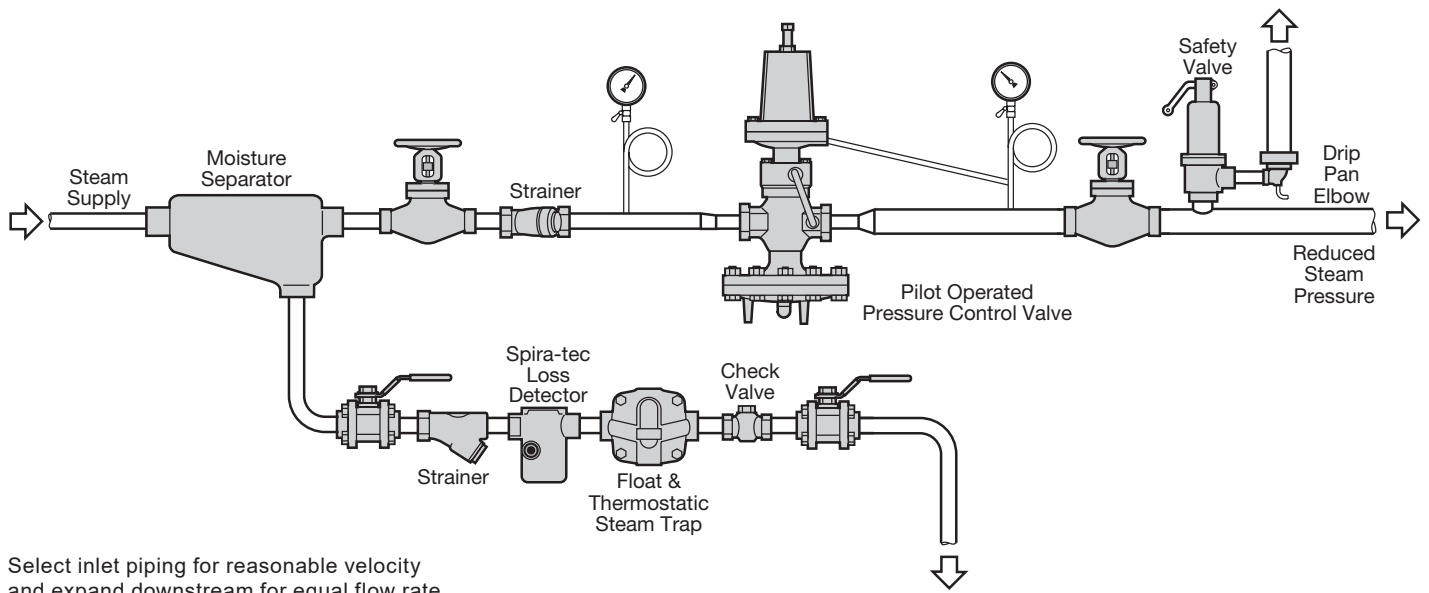

Select inlet piping for reasonable velocity and expand downstream for equal flow rate.

Fig. 1 Typical Pressure Reducing Valve Station

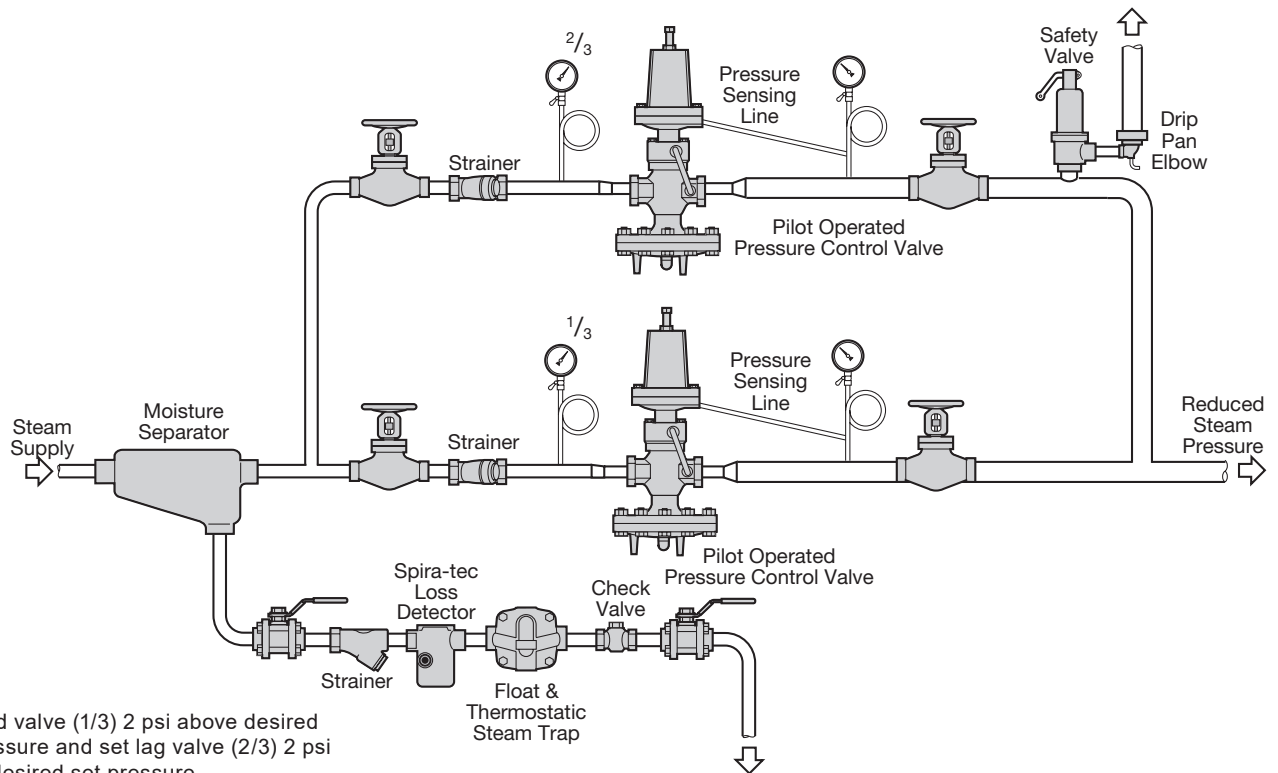

Set lead valve (1/3) 2 psi above desired set pressure and set lag valve (2/3) 2 psi below desired set pressure.

Fig. 2 Parallel Operation of Pressure Reducing Valves

Type 25P, 25PA, 26P and 26PA Pressure Reducing Valves

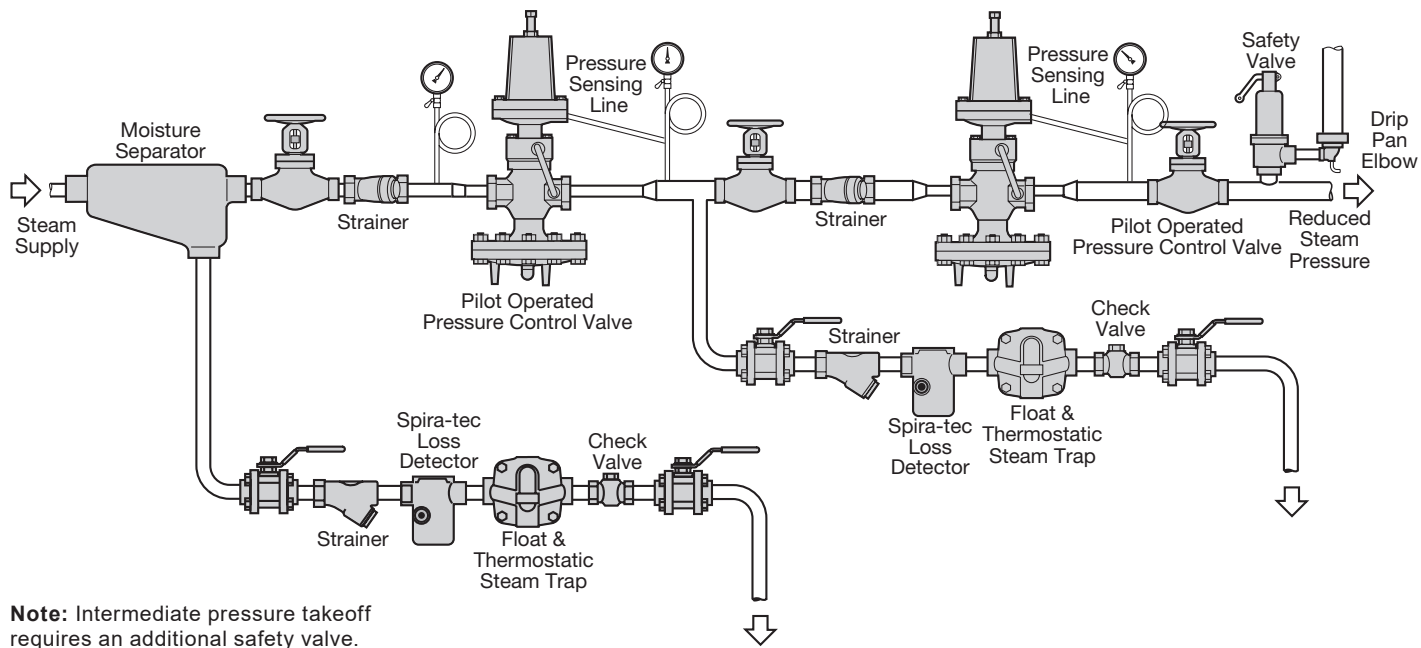

Note: Intermediate pressure takeoff requires an additional safety valve.

Fig. 3 Series Pressure Reducing Valve Station for High Turndown Ratios

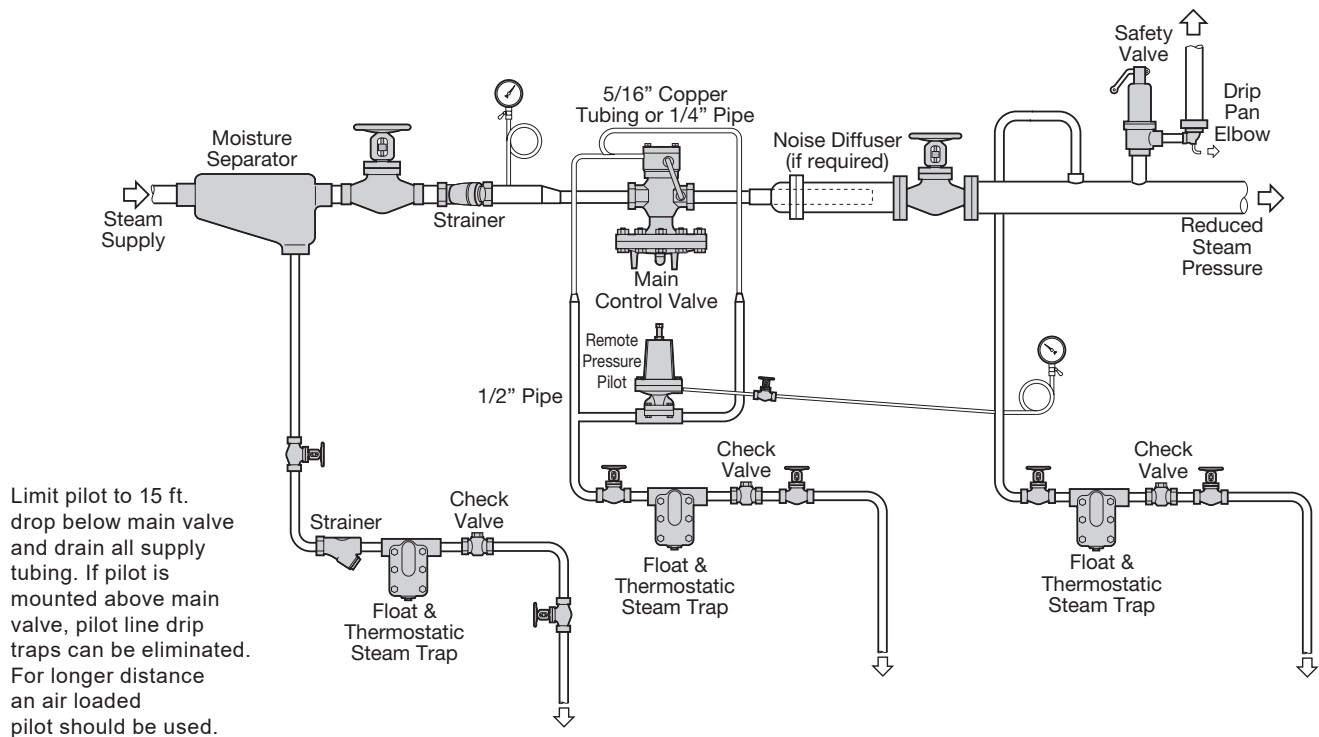

Limit pilot to 15 ft. drop below main valve and drain all supply tubing. If pilot is mounted above main valve, pilot line drip traps can be eliminated. For longer distance an air loaded pilot should be used.

Fig. 4 Hook-up for Remote Operation of 25 PRM Pressure Reducing Valve

Type 25P, 25PA, 26P and 26PA Pressure Reducing Valves

How the 25P, 25PA, 26P and 26PA work

Normal positions before start-up are with the main valve closed and the pilot valve held open by spring force or air pressure. Entering steam passes through the pilot valve into the main diaphragm chamber and also out through the control orifice. As flow through the pilot valve exceeds flow through the orifice, control pressure increases in the diaphragm chamber and opens the main valve. As steam flows through the main valve, the increase in downstream pressure feeds back through the pressure sensing line to the underside of the pressure diaphragm. When the force below that diaphragm balances the compression force of the spring above it, the pilot valve throttles. The control pressure maintained in the main diaphragm chamber positions the main valve to deliver just enough steam for the desired delivery pressure. Adjustment of the spring or air pressure above the pressure diaphragm changes the downstream pressure set point. When steam is no longer required, the sensing line pressure increases closing the pressure pilot and the control pressure bleeds back through the control orifice. This allows the main valve to hold the desired reduced

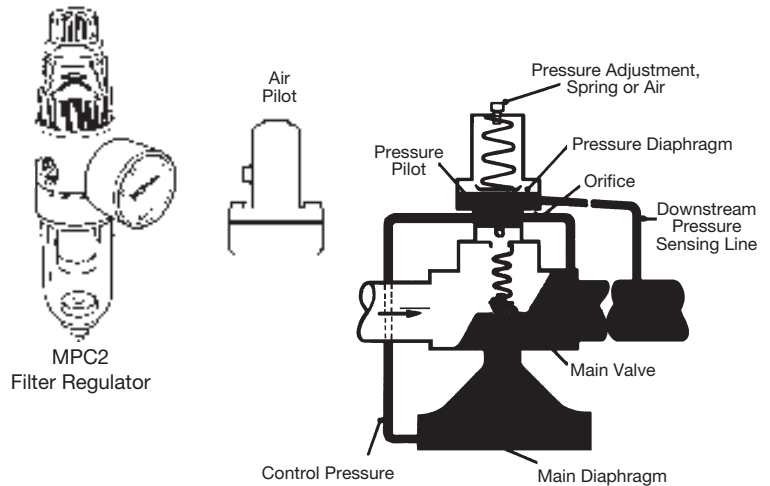

Start-up

1. First make certain that all stop valves are closed.
2. Remove pilot spring cover then turn the pressure pilot adjustment (2D) counter-clockwise until spring is slack. Make certain spring remains in vertical position and centered in its retainers. Air loaded PA pilots must have no air pressure supplied to them.
3. Open stop valves in the following order:
 - a. Open stop valve ahead of steam trap on steam supply line. This will insure water free steam at the regulator inlet when put into operation.
 - b. Open small gate valve on pressure sensing line.
 - c. Slowly open inlet stop valve.
4. Slowly adjust pilot spring at (2D) turning clockwise until reduced pressure required is indicated on pressure gauge downstream of valve.
5. Once the system has stabilized itself, slowly open down-stream isolation valve. It may be necessary to make re-adjustment of pilot spring (2D). Replace spring cover then tighten adjustment locknut.
6. Important-- Retighten all pilot flange connections to insure steam tight joints.
7. Air Loading PA Pilot requires air loading as indicated in the following table.

Desired Outlet Steam Pressure P2 psi g	5	10	25	50	75	100
Inlet Pressure P1 psi g	10 psi g to 100 psi g					
Approximate	11	16	31	56	80	102
Air Set Pressure	to	to	to	to	to	to
psi g	13.5	16.8	33.5	58	81	103

3. Troubleshooting

(Refer to Figs. 6, 7 and 8)

Symptom	Cause	Check and Cure
1. Controlled pressure overshoots under normal load conditions	(a) Dirt or foreign material between pilot valve seat and head.	(a) Loosen screw (2D). Remove copper tubing connections at (J and L). With steam on valve, if steam flows from copper tubing connections at (J and L) remove pilot head and seat assembly (2H) and clean or replace.
	(b) Foreign particles between main valve head and seat.	(b) Inspect and clean head and seat
	(c) Orifices (B) and (H) or pressure sensing line may be plugged.	(c) Remove, inspect and clean.
2. Controlled pressure overshoots only on light loads.	(a) Main valve head and seat worn or dirt between them.	(a) Inspect and clean head and seat.
	(b) Valve may be severely oversized.	(b) Adjust screw (2D) to give desired pressure under light loads.
	(c) Bypass valve not shut tightly or leaking.	(c) Check and repair as required.
	(d) Dirt or foreign material on main valve stem and guide (1F).	(d) Remove, inspect and clean.
3. Valve fails to open.	(a) Main valve diaphragm ruptured.	(a) Unscrew copper tubing connection at (G) and crack bypass valve. If steam flows from main valve diaphragm case, diaphragm is defective and must be replaced.
	(b) Orifice (H) is plugged	(b) Remove and clean.
	(c) Pilot valve seat is plugged with dirt.	(c) Remove head and seat assembly (2H). Inspect and clean or replace.
	(d) Screen (1D) is plugged.	(d) Inspect screen and clean.
	(e) Pipeline strainer blocked.	(e) Inspect and clean.
	(f) Pilot valve adjustment (2D) or air loading pressure not properly adjusted.	(f) Adjust screw (2D) to desired pressure Check air supply to PA pilots.
4. Delivery pressure low.	(a) Pilot valve adjustment (2D) not properly adjusted.	(a) Adjustment screw (2D) to desired pressure.
	(b) Valve undersized.	(b) Check actual load against valve rating.
	(c) Steam supply pressure too low.	(c) Check and correct.
	(d) Main valve diaphragm ruptured.	(d) Unscrew copper tubing connection (G) and crack bypass valve. If steam flows from diaphragm case, diaphragm is defective and must be replaced.
	(e) Bleed orifice (B) missing.	(e) Replace proper fitting.
5. Valve fails to close.	(a) Bypass valve open or leaking.	(a) Check and repair as required.
	(b) Pilot sensing line blocked (or not installed).	(b) Remove, inspect, clean or install.
	(c) Pilot ruptured (water or steam coming from pilot at spring retainer area).	(c) Replace pilot diaphragm assembly.
	(d) Pilot assembly or main valve seat threads leaking.	(d) Check casting in seat area for erosion.
	(e) Main valve diaphragm reassembled without return spring and main valve cover holding valve head closed.	(e) With main valve cover installed, loosen all main valve diaphragm bolts (1C) and then retighten. (½" through 4" sizes only).

4. Maintenance

General Inspection

While a program of planned maintenance is always to be recommended, the Spirax Sarco 25P and 26P valve will give long and trouble-free service if correctly selected, installed and kept reasonably free of dirt and foreign matter. Dirt and foreign matter are most likely to collect during installation and later trouble can be avoided by inspecting the installation after a few days. Check the following:

1. Clean all pipeline strainers. (Remove screens to clean.)
2. Check the main valve seat (1E) and protective screen (1D).
3. Inspect and clean orifices (B) and (H).
4. Check all joints for leakage.

Servicing Procedure (Refer to Fig. 6 and 9)

To determine which part of a malfunctioning pressure reducing valve requires maintenance, refer to the troubleshooting chart and follow this servicing procedure to check the tightness of the seats.

1. With all stop valves closed and the valve cooled down, remove the copper tubing from connectors (J) and (L) being careful not to bend them.
2. Close the pilot valve (2H) by turning the pressure adjustment (2D) counter-clockwise until the spring is slack. (No air pressure supplied to the type PA pilot).
3. Stand clear of the tubing connectors and open the inlet stop valve slightly so that a small amount of steam reaches the valve inlet and pilot.
4. Open and close the pilot valve a few times by turning the pressure adjustment (2D) and observe the steam flow from tubing connectors (J) and (L). When the pilot valve is closed, there should be no steam flow from the connectors; if there is some steam flow, it indicates that the pilot valve assembly (2H) is faulty and must be replaced.
5. With the copper tubing removed the main valve head and seat are held closed and should not pass any steam. Observe the downstream orifice connector (B). Steam flow from this connector indicates that the main valve head and seat are leaking and require servicing.

Inspecting and Replacing Pilot Valve Head and Seat (Refer to Fig. 6 and 9)

1. Remove 4 pressure pilot flange cap screws and lift off pressure pilot. Visual examination can be made of the pilot valve head and seat.
2. Pilot valve head and seat are contained in one complete assembly. (See Fig. 6.)
3. To remove head and seat assembly (2H), unscrew hexagon, using 11/16" hex wrench.
4. If it is found that either the head or seat is worn, the entire assembly should be replaced.

Inspecting and Replacing Pilot Valve Diaphragms (Refer to Fig. 6 and 9)

1. Turn adjustment screw (2D) counterclockwise until spring is slack. Air loaded PA pilots must have no air pressure supplied to them.
2. Remove cap screws (2C). Pilot yoke (2B) can then be removed.
3. The 2 metal diaphragms (2F) can then be inspected for distortion or possible fracture as a result of abnormal operation.
4. At the same time any accumulation of dirt or foreign material should be removed from the lower diaphragm pilot case.
5. When replacing diaphragms, make certain casting surface is clean to insure a steam tight joint. Application of a plastic compound on the casting surface, such as Garlock 101, is recommended.
6. Position pilot yoke on lower diaphragm pilot casting making certain that the yoke is properly centered.
7. Tighten all cap screws uniformly. To an assembly torque of 15-20 ft/lbs.

Valve Sizes ½" through 4"

Inspecting and Replacing Main Valve Head and Seat (Refer to Figs. 6, 7, and 9)

1. Unscrew copper tubing connections at (J) and (L).
2. Remove main valve cover cap screws (1A).
3. Remove main valve cover, strainer screen (1D), spring support disc and head spring.
4. Head can then be removed by simply withdrawing with a pliers or similar tool.
5. Inspection should then be made to determine if scale or other foreign material prevented tight closure of the head and seat.
6. If it is necessary to replace the valve seat, this can be removed from the valve body using a standard hexagon socket. (Valve sizes ½" to 2".) When replacing the valve seat, a new gasket should be used to insure a tight joint. 2½" through 6" valves contain raised lugs for removal and seal metal-to-metal without a gasket. Replacement heads and seats should be lapped in.

Valve Sizes ½" through 4"

Inspecting and Replacing Main Valve Diaphragms (Refer to Figs. 5, 6, 7, and 9)

1. Unscrew copper tubing connection at (G).
2. Remove main valve diaphragm bolts (1C).
3. This will allow the lower diaphragm case to be removed.
4. The 2 metal diaphragms (1H) should be inspected to insure that they have not become distorted or possibly fractured as a result of abnormal operating conditions.
5. At the same time any accumulation of dirt or foreign material should be removed from the diaphragm case.
6. The valve stem should also be checked to make sure it is free to move and that there is no scale or foreign material lodged in the guide bushing (1F).
7. Before reassembling diaphragms in ½" through 4" sizes, main valve head must be in place and head in a closed position with the return spring and main valve cover.
8. Make certain pressure plate (1G) is set properly. (Refer to Fig. 5.)
9. Care should be taken in centering the diaphragms properly and equalizing bolt take-up uniformly.

6" Valve (25P and 25PA) Only

Inspecting and Replacing Main Valve Diaphragm, Seat, and Head Assembly (Refer to Fig. 8)

Diaphragms

1. Unscrew copper tubing connections (G) to lower diaphragm chamber.
2. Remove main valve diaphragm bolts (1C) and drop lower diaphragm case.
3. The 2 metal diaphragms (1H) should be inspected and replaced if they have become distorted or fractured.
4. Clean any accumulation of dirt from the diaphragm case and orifice (H).

Servicing the Main Valve Head and Seat

5. Loosen the diaphragm plate set screw and remove the diaphragm plate (1G).
6. Remove the top cover bolts (1A) and cover.
7. Remove the stem and head assembly from the valve. Inspect the head and seat for wear.
8. Check the body erosion around the seat ring.
9. Replacement seats and heads should be lapped in, and minor wear can be corrected by lapping with 400 grit compound.
10. On re-assembly be sure diaphragm plate (1G) is set and set screw securely tightened.

NOTE: For replacement parts refer to Spirax Sarco Replacement Parts Reference Guide.

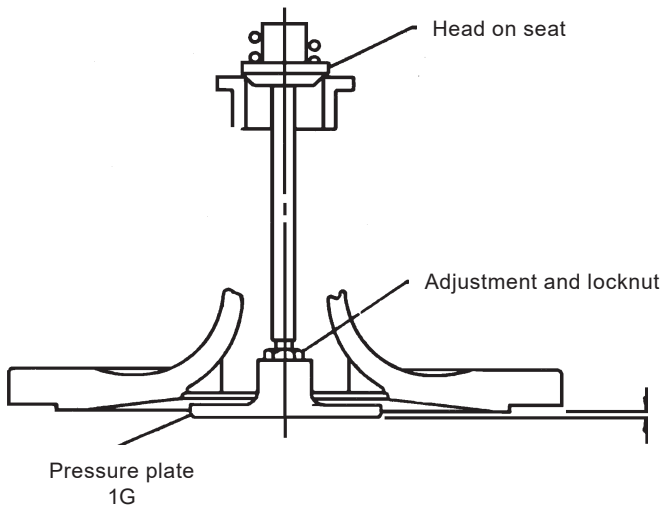

Fig. 5

Note in 1/2" and 4" sizes, top of valve must be completely assembled and head must be on seat when measuring dimension "A" and when re-assembling diaphragms.

Size	1/2" and 3/4"	1"	1 1/4" and 1 1/2"	2"	2 1/2"	3"	4"
Dimension A	1/16"	5/64"	3/32"	1/8"	13/64"	13/64"	1/4"

Fig. 6
1/2" to 2" sizes

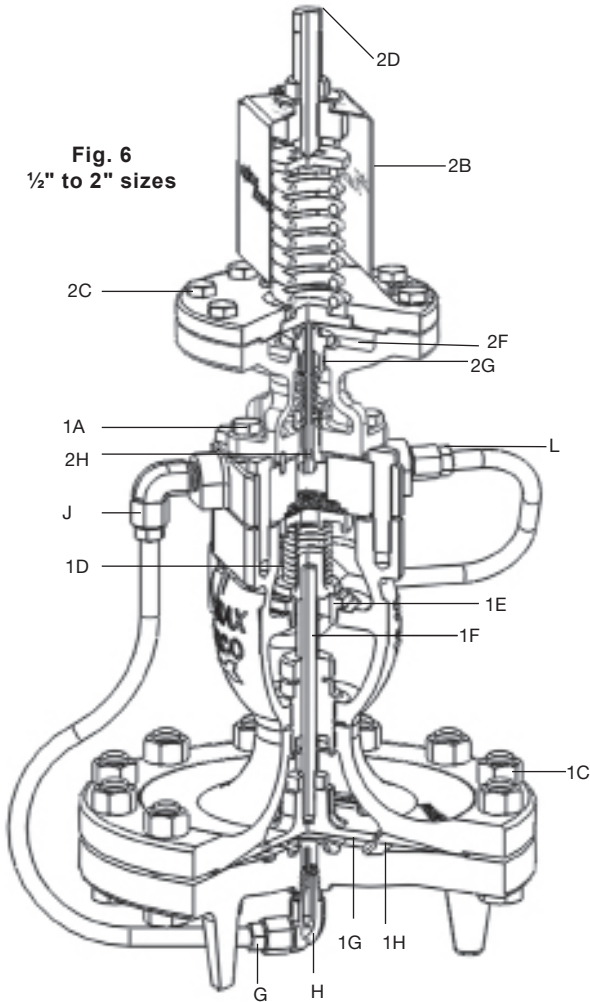
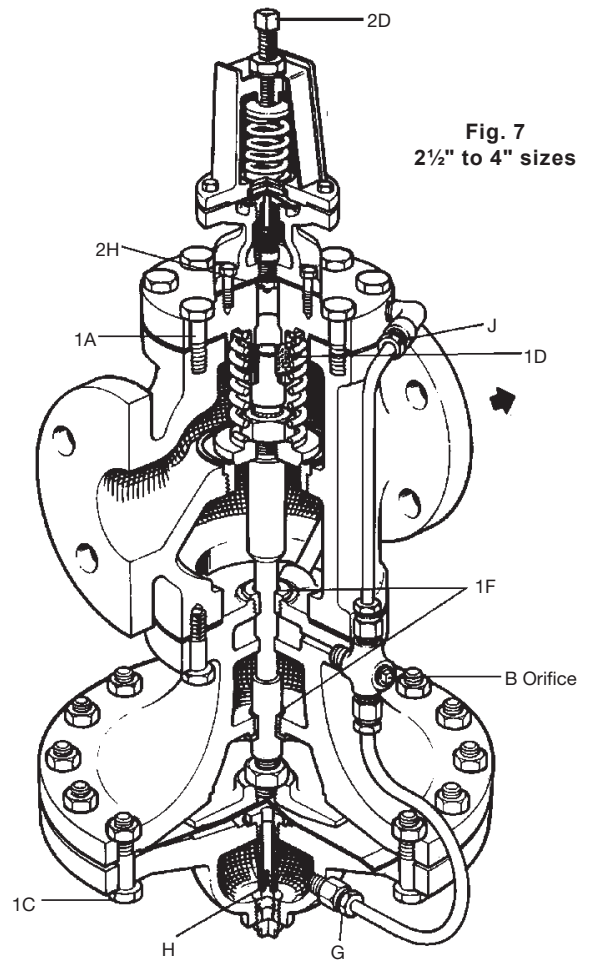

Fig. 7
2 1/2" to 4" sizes



Type 25P, 25PA, 26P and 26PA Pressure Reducing Valves

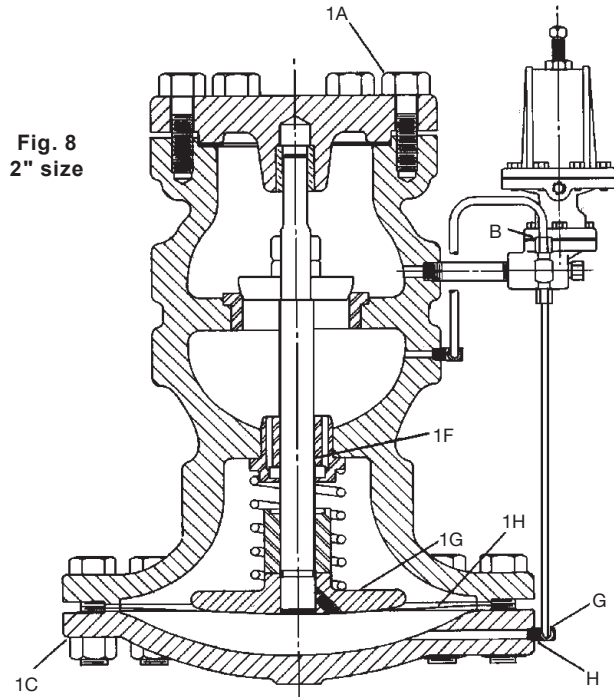

Fig. 8
2" size

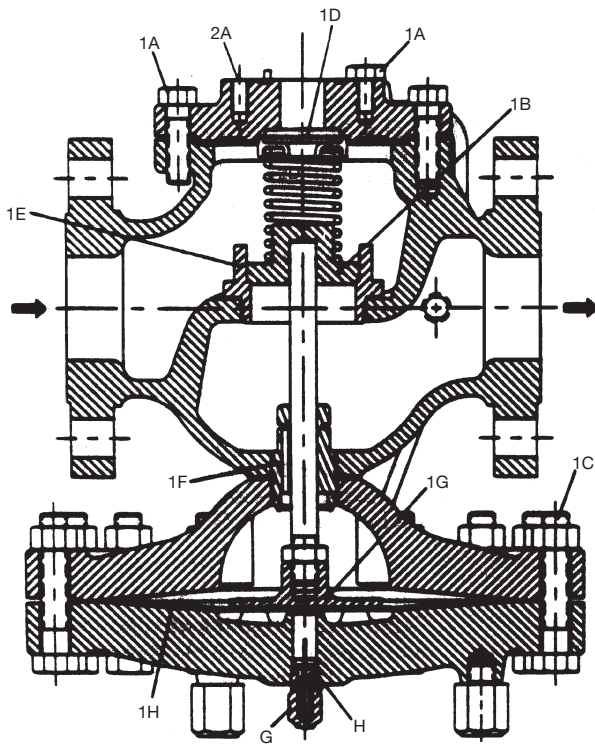
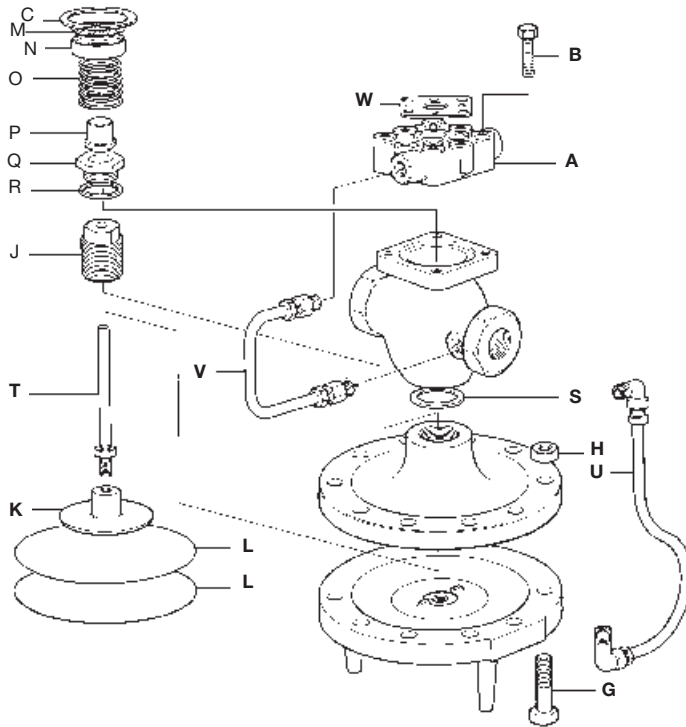

Fig. 9
2" Class 300, 25 valve components

5. Spare parts

½" to 2"



2½" to 4"

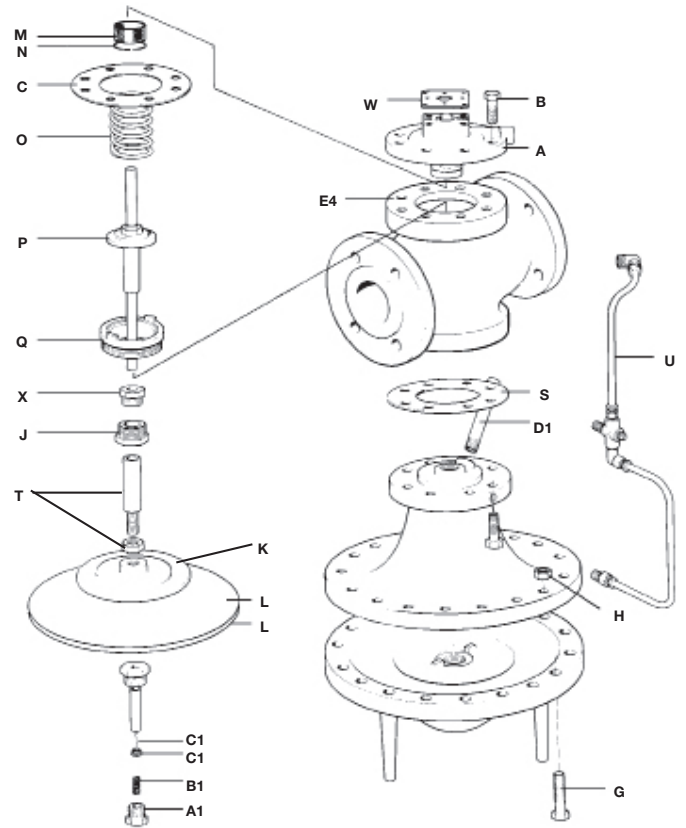

Cover Assembly w/ Cap Screws and Gasket	A, B, C
Diaphragm Case Bolts and Nuts	G, H
Screen, Spring Support Disc, Valve Spring and Cap Gasket	M, N, O, C
Cap Gasket, Valve Head, Seat and Seat Gasket (2) specify regular or reduced port "S" valve	C, P, Q, R
Valve Stem Guide and Gasket	J, S, T
Diaphragm Plate	K
Diaphragms (2 ply)	L
Transmission Tubing w/ Assembly	U, V
Gasket Kit	C, R, S, W
Rebuild Kit	B, C, L, M, O, P, Q, R, U, V, W

Cover Assembly w/ Cap Screws and Gasket	A, B, C
Diaphragm Case Bolts and Nuts	G, H
Screen, Spring Support Disc, Valve Spring and Cap Gasket	M, N, O, C
Cap Gasket, Valve Head, Seat and Seat Gasket (2) specify regular or reduced port "S" valve	C, P, Q, X
Diaphragms (2 ply)	L
Transmission Tubing w/ Assembly	U
Gasket Kit	S, W, C
Damping Assembly	A1, B1, C1
Diaphragm Plate	K
Lower Stem and Guide	J, T
Relief Tube	D1
Rebuild Kit	B, C, L, M, O, P, Q, R, U, W

Type 25P, 25PA, 26P and 26PA Pressure Reducing Valves

Transmission tubing

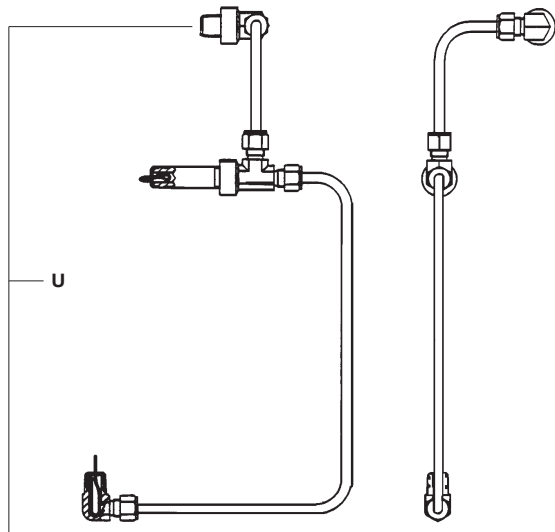

6" (25P and 25PA, only)

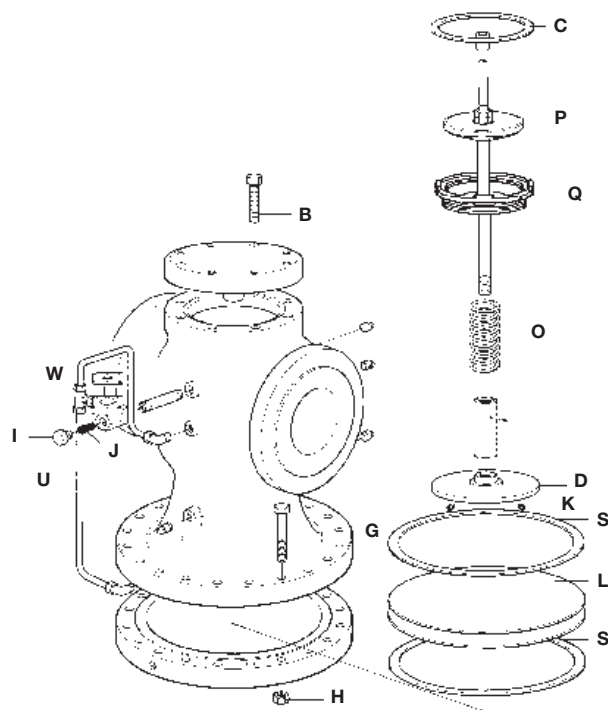

Transmission Tubing Spares Installation Instructions

Sizes 2½" – 4"

1. Remove "T" connector from tubing and thread male adapter bleeder assembly into hole at the top of the upper diaphragm case
 - a. Ensure 90° connection faces up
2. Insert 90° elbow with tubing into cover assembly
 - a. Hold elbow in place (vice grips suggested) and bend tubing by hand (can use rubber mallet) to align with open end of "T" connector
3. Use a 5/8" wrench to tighten both joints ensuring that "T" connector and 90° elbow do not rotate

Main Valve Spring and Lower Diaphragm Cover Gaskets	O, S
Diaphragm Plate and Set Screws	K, D
Transmission Tubing with Fittings	U*
Diaphragms (2 per set)	L*
Gasket Kit	C, S, W*
Head, Stem and Seat Assembly "S" Head, Stem and Seat Assembly	P, Q, C
Screen Assembly	I, J
Cover Bolt Kit	B
Diaphragm Case Bolt Kit	G, H

Spares Kits

* A standby set of spares for general maintenance purposes includes all spares marked



6. How to Size Piping for 25- and 26- Series Regulators

Principle

When steam pressure is lowered through a reducing valve, the steam expands creating a higher velocity. The extreme velocities that must exist across reducing valve seats cannot be tolerated in pipes supplying the valves and leading from them. Erosion and noise would be prohibitive.

It is recommended practice in heating systems to limit velocities to between 4,000 and 6,000 feet per minute. Higher velocities are often acceptable outdoors and in plants where the environment is already noisy.

This chart lists steam capacities of pipes under various pressure and velocity conditions.

Example

Given a steam heating system with a 100 psi g inlet pressure ahead of the pressure reducing valve and a capacity of 1,000 pounds per hour at a reduced pressure of 25 psi g, find the smallest sizes of upstream and downstream piping for reasonable steam velocities.

Upstream Piping

Enter the velocity chart at point A for 1,000 pounds per hour. Proceed horizontally to point B where the 100 psi g diagonal line intersects. Follow up vertically to point C where an intersection with a diagonal line falls inside the 4,000 to 6,000 feet per minute velocity band. Actual velocity (see point D) is about 4,800 feet per minute for 1½" upstream piping.

Downstream Piping

Enter the velocity chart at point A for 1,000 pounds per hour. Proceed horizontally to point E where the 25 psi g diagonal line intersects. Follow up vertically to point F where an intersection with a diagonal line falls inside the 4,000 to 6,000 feet per minute velocity band. Actual velocity (see point G) is about 5,500 feet per minute for 2½" downstream piping.

