

SRV66
Sanitary Pressure Reducing Valve
Installation and Maintenance Instructions

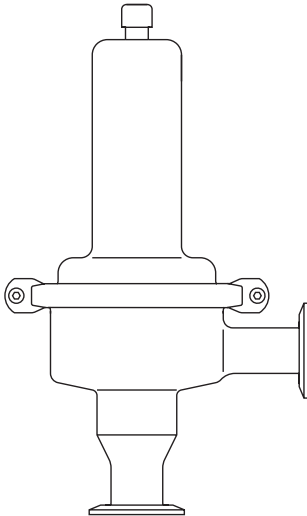

1. Safety information
2. General product information
3. Installation
4. Operation
5. Commissioning
6. Maintenance
7. Spare parts

1. Safety information

Safe operation of the unit can only be guaranteed if it is properly installed, commissioned and maintained by a qualified person (see Section 1.11) in compliance with the operating instructions. General installation and safety instructions for pipeline and plant construction, as well as the proper use of tools and safety equipment must also be complied with.

1.1 Intended use

Referring to these Installation and Maintenance Instructions, Name-plate and Technical Information Sheet, check that the product is suitable for the intended use/application. The product complies with the requirements of the EU Pressure Equipment Directive/UK Pressure Equipment (Safety) Regulations and falls within Category 'SEP'. It should be noted that products within this category are required by the Directive not to carry the  mark.

- i) The product has been specifically designed for use on steam, water and inert industrial gases. These fluids are in Group 2 of the above mentioned Pressure Equipment Directive. The product's use on other fluids may be possible but, if this is contemplated, Spirax Sarco should be contacted to confirm the suitability of the product for the application being considered.
- ii) Check material suitability, pressure and temperature and their maximum and minimum values. If the maximum operating limits of the product are lower than those of the system in which it is being fitted, or if malfunction of the product could result in a dangerous overpressure or overtemperature occurrence, ensure a safety device is included in the system to prevent such over-limit situations.
- iii) Determine the correct installation situation and direction of fluid flow.
- iv) Spirax Sarco products are not intended to withstand external stresses that may be induced by any system to which they are fitted. It is the responsibility of the installer to consider these stresses and take adequate precautions to minimise them.
- v) Remove protective covers from all connections and protective film from all name-plates, where appropriate, before installation on steam or other high temperature applications.

1.2 Access

Ensure safe access and if necessary a safe working platform before attempting to work on the product. Arrange suitable lifting gear if required.

1.3 Lighting

Ensure adequate lighting, particularly where detailed or intricate work is required.

1.4 Hazardous liquids or gases in the pipeline

Consider what is in the pipeline or what may have been in the pipeline at some previous time. Consider; flammable materials, substances hazardous to health, extremes of temperature.

1.5 Hazardous environment around the product

Consider; explosion risk areas, lack of oxygen (e.g. tanks, pits), dangerous gases, extremes of temperature, hot surfaces, fire hazard (e.g. during welding), excessive noise, moving machinery.

1.6 The system

Consider the effect on the complete system of the work proposed. Will any proposed action (e.g. closing isolation valves, electrical isolation) put any other part of the system or any personnel at risk?

Dangers might include isolation of vents or protective devices or the rendering ineffective of controls or alarms. Ensure isolation valves are turned on and off in a gradual way to avoid system shocks.

1.7 Pressure systems

Ensure that any pressure is isolated and safely vented to atmospheric pressure. Consider double isolation (double block and bleed) and the locking or labelling of closed valves. Do not assume that the system has depressurised even when the pressure gauge indicates zero.

1.8 Temperature

Allow time for temperature to normalise after isolation to avoid the danger of burns and consider whether protective clothing (including safety glasses) is required.

PTFE 'O' ring

If the PTFE 'O' ring used inside the unit has been subjected to a temperature approaching 260°C or higher, it will give off toxic fumes, which if inhaled is likely to cause temporary discomfort. It is essential for a no smoking rule to be enforced in all areas where PTFE is stored, handled or processed as persons inhaling the fumes from burning tobacco contaminated with PTFE particles can develop 'polymer fume fever'.

1.9 Tools and consumables

Before starting work ensure that you have suitable tools and/or consumables available. Use only genuine Spirax Sarco replacement parts.

1.10 Protective clothing

Consider whether any protective clothing is required by yourself and/or others in the vicinity to protect against the hazards of, for example, chemicals, high/low temperature, noise, falling objects, and dangers to eyes and face.

1.11 Permits to work

All work must be carried out or be supervised by a suitably competent person. Installation and operating personnel should be trained in the correct use of the product according to these instructions.

Where a formal 'permit to work' system is in force it must be complied with. Where there is no such system, it is recommended that a responsible person should know what work is going on and, where necessary, arrange to have an assistant whose primary responsibility is safety. Post 'warning notices' if necessary.

1.12 Handling

Manual handling of Spirax-Sarco products may present a risk of injury. Lifting, pushing, pulling, carrying or supporting a load by bodily force can cause injury particularly to the back. You are advised to assess the risks taking into account the task, the individual, the load and the working environment and use the appropriate handling method depending on the circumstances of the work being done.

1.13 Residual hazards

In normal use the external surface of the product may be very hot. If used at the maximum permitted operating conditions the surface temperature of some products may reach temperatures of 180°C.

Many products are not self-draining. Take due care when dismantling or removing the product from an installation (refer to 'Maintenance instructions').

1.14 Freezing

Provision must be made to protect products which are not self-draining against frost damage if they are inoperative in environments where they may be exposed to temperatures below freezing point.

1.15 Safety information - Product specific

This product should not be dismantled without first releasing the compression on the control spring.

1.16 Disposal

This product is recyclable and no ecological hazard is anticipated with its disposal providing due care is taken, EXCEPT:

PTFE protective film:

- Can only be disposed of by approved methods, not incineration.
- Keep PTFE waste in a separate container, do not mix it with other rubbish, and consign it to a landfill site.

1.17 Returning products

Customers and stockists are reminded that under UK and EC Health, Safety and Environment Law, when returning products to Spirax Sarco they must provide information on any hazards and the precautions to be taken due to contamination residues or mechanical damage which may present a health, safety or environmental risk. This information must be provided in writing including Health and safety data sheets relating to any substances identified as hazardous.

2. General product information

2.1 Description

The SRV66 is an angle pattern self-draining sanitary pressure regulating valve of all 316 type stainless steel construction suitable for use on steam, water and inert industrial gases. It is available with sanitary clamp compatible connections to ISO 2852, requires no external pressure sensing line and has clean in place (CIP) and sterilise in place (SIP) capability.

Typical applications include: Clean steam, gas and liquid supplies to bioreactors, centrifuges, freeze dryers, sterilisers, autoclaves, process tanks, humidifiers and culinary equipment.

Valve tightness

Valve tightness is in accordance with VDI/VDE guideline 2174 (leakage rate < 0.5% of K_v s value).

Standard surface finish and cleaning

Internal wetted parts - $R_a < 3.2 \mu\text{m}$ (126 μin) ultrasonically cleaned.

Note: For additional product data see Technical Information sheet TI-P186-08.

2.2 Sizes and pipe connections

DN15, DN20, DN25, DN32, DN40, and DN50 (1/2", 3/4", 1", 1-1/4", 1-1/2", and 2") ISO 2852 sanitary clamp compatible.

Please note: For other end connections contact Spirax Sarco.

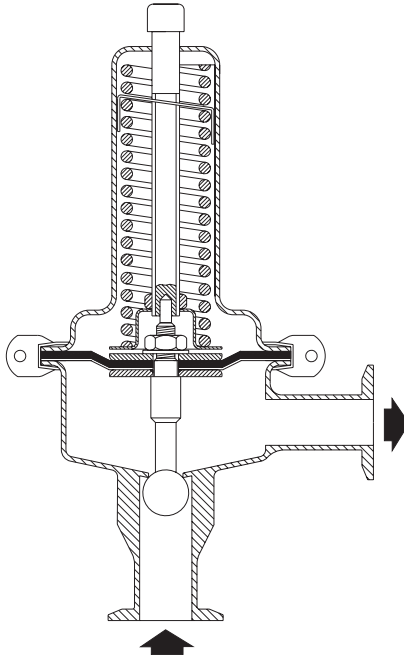
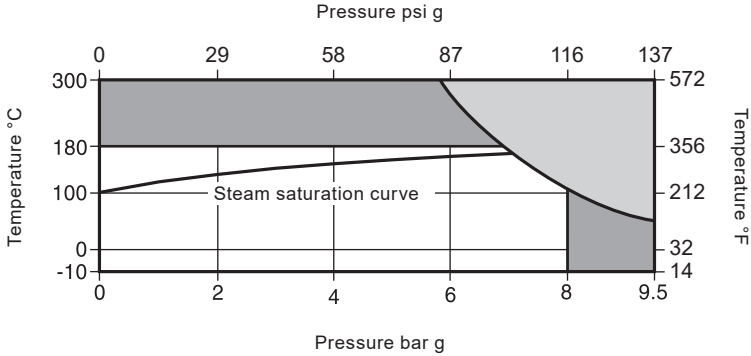

Fig. 1 SRV66

SRV66 Sanitary Pressure Reducing Valve

2.3 Pressure/temperature limits



- The product **must not** be used in this region.
- The product should not be used in this region or beyond its operating range as damage to the internals may occur.

Body design conditions	Inlet	PN10
	Outlet	see 'Pressure setting range' below
Maximum design pressure	9.5 bar @ 50 °C (137 psi g @ 122 °F)	
Maximum design temperature	300 °C @ 5.8 bar (572 °F @ 84 psi g)	
Minimum design temperature	-10 °C (14 °F)	
Maximum operating temperature	180 °C (356 °F)	
Maximum operating pressure (inlet)	8 bar g (116 psi g)	
Minimum operating temperature	-10 °C (14 °F)	
Designed for a maximum cold hydraulic test pressure of	15.2 bar g (220 psi g)	

2.4 Pressure setting range

Size	DN15 - DN50 (½" - 2")		
	PN10/PN2.5	PN10/PN6	PN10/PN10
Spring range	0.3 - 1.1 bar g (4.3 - 15.9 psi g)	0.8 - 2.5 bar g (11.6 - 36.2 psi g)	1.0 - 5.0 bar g (14.5 - 72.5 psi g)
Maximum permitted outlet pressure = 1.5 times set pressure			

SRV66 Sanitary Pressure Reducing Valve

2.5 Dimensions/weights (approximate) in mm and kg

Pressure range	Size	A	B	C	Weight
1.0 to 5.0 bar and 08. to 2.5 bar	DN15 - DN25 (½" - 1")	90 (3.5)	138 (5.4)	200 (7.8)	2.0 (4.4)
(14.5 to 72.5 psi and 11.6 to 36.2 psi)	DN32 - DN40 (1¼" - 1½")	120 (4.7)	138 (5.4)	200 (7.8)	2.5 (5.5)
	DN50 (2")	120 (4.7)	138 (5.4)	200 (7.8)	3.0 (6.6)
0.3 to 1.1 bar (4.3 to 15.9 psi)	DN15 - DN25 (½" - 1")	120 (4.7)	200 (7.8)	200 (7.8)	3.0 (6.6)
	DN32 - DN40 (1¼" - 1½")	120 (4.7)	200 (7.8)	200 (7.8)	3.5 (7.7)
	DN50 (2")	120 (4.7)	200 (7.8)	200 (7.8)	4.0 (8.8)

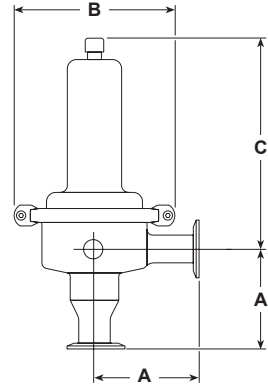

3. Installation

3.1 General information

Before installing the valve thoroughly flush the pipeline. Ideally the valve should be installed in a pressure reducing valve station, see Figure 2, at the very minimum there should be a separator and strainer fitted upstream, these should be serviced at regular intervals. The SRV66 should always be fitted with the inlet horizontal and the spring housing directly above the valve. Most applications will require a safety valve to be installed downstream in case of accidental overpressure. It should be noted that the valve should not be used as a shut-off valve, a separate valve should therefore be used for isolation purposes if required.

If it is possible for equipment downstream of the valve to be shut off then a further trap set should be installed to prevent downstream flooding.

The pressure reducing valve should not be insulated as this may lead to over heating and destroy the elastomer seals.

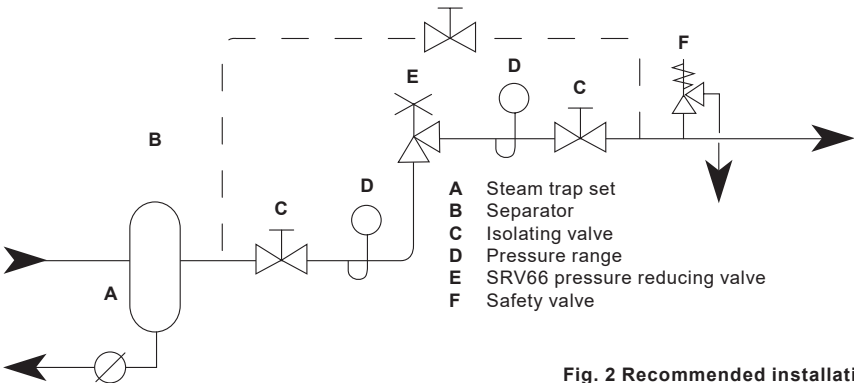

Fig. 2 Recommended installation

SRV66 Sanitary Pressure Reducing Valve

spirax
sarco

4. Operation

4.1 How the SRV66 works

As steam or other operating fluid passes through the valve the pressure on the downstream side of the valve increases and acts directly on the diaphragm. Pressure acting on the area of the diaphragm transmits a force which acts against that of the control spring. When the downstream pressure exceeds the set pressure the force acting through the diaphragm will overcome the force of the control spring and the valve will shut. Conversely, if the downstream pressure is too low then the control spring will exert sufficient force to open the valve.

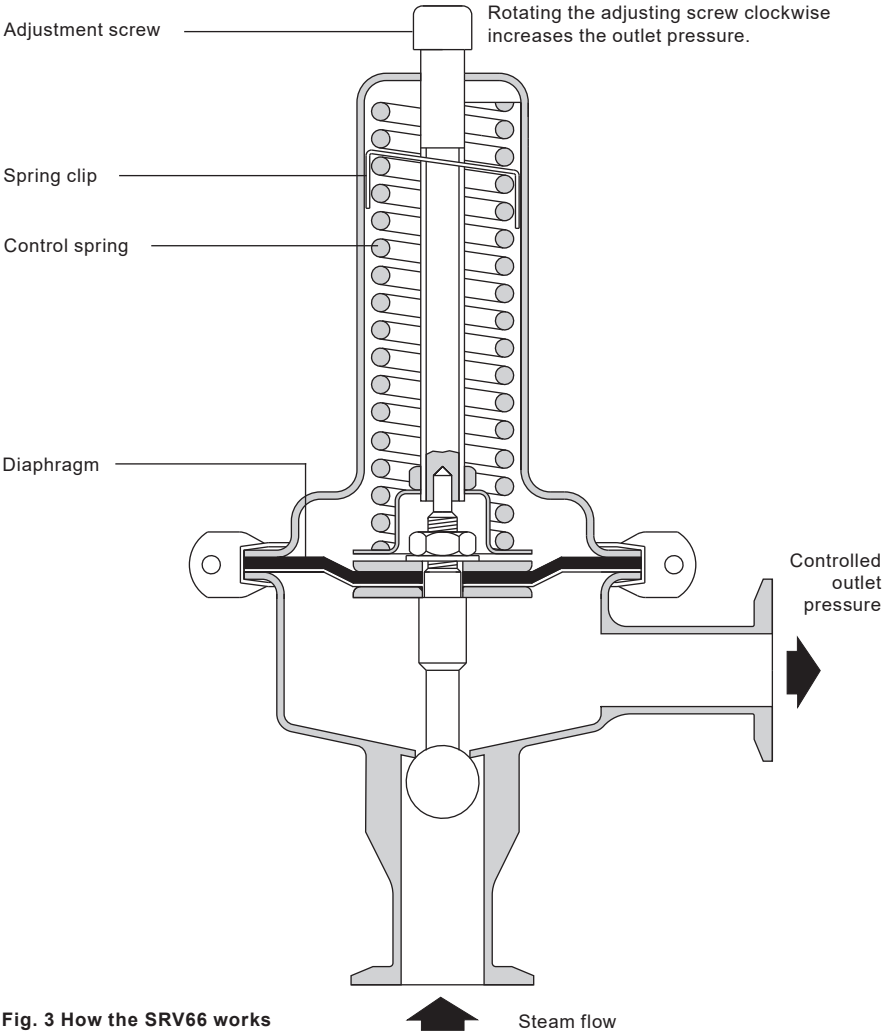

Fig. 3 How the SRV66 works

5. Commissioning

5.1 Start-up and adjustment:

- First make sure that all stop valves are closed.
- Check that the control spring is not compressed, wind the adjuster screw anticlockwise if necessary.
- Open the stop valves in the following order:
 - i - Open the stop valves immediately in front of the steam traps (C1).
 - ii - Open the downstream stop valve (C2).
 - iii - Very gently open the upstream valve on the inlet supply line (not shown) to avoid any sudden mechanical or thermal shock.
- Slowly turn the adjuster screw clockwise until the desired downstream pressure is achieved (D). If the valve is set under no-load conditions then there will be a proportional offset causing the controlled pressure to drop by about 20% under flowing conditions. If the valve is set under normal flowing conditions then there will be a pressure rise of about 20% due to the proportional offset of the valve as the load reduces to zero. It is important that any downstream safety valve (F) is set such that the no-load set pressure of the SRV66 is below the safety valve reseal pressure.

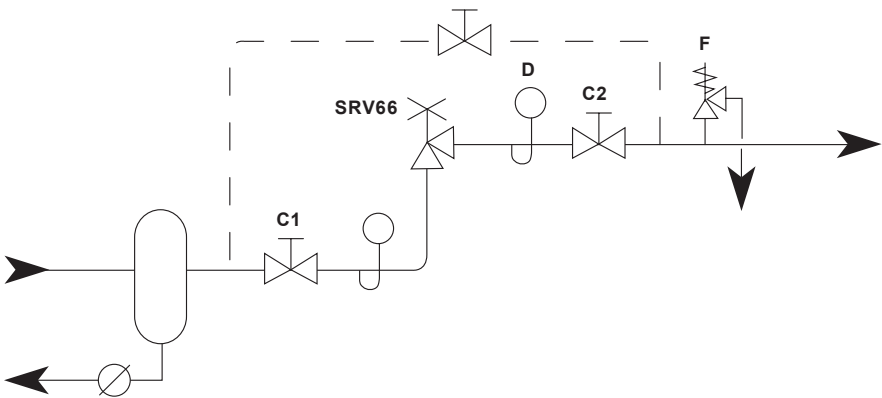

Fig. 4 SRV66 - Commissioning

6. Maintenance

6.1 General inspection

While a programme of planned maintenance is always recommended, the Spirax Sarco SRV66 will give long and trouble free service if correctly selected, installed and kept free of dirt and foreign matter. Dirt and foreign matter are most likely to collect during installation and later trouble can be avoided by inspecting the installation after a few days.

Check the following:

- Clean all pipeline filters or strainers (remove elements or screens to clean).
- Check all joints for leakage.

6.2 Inspecting/replacing diaphragm and valve assembly:

- Before attempting any maintenance operation read the product specific safety information in Section 1.15.
- Isolate the valve, first closing the upstream isolating valve (C1) and then the downstream isolating valve (C2). Check that the pressure is zero (D) and allow the valve to cool (see Figure 5).
- Release the compression on the control spring (5) by turning the adjustment screw (4) anticlockwise.
- Remove the SRV66 from the pipeline.
- Lift off the spring housing (3) and the control spring (5) by first releasing the 'V' band clamp screws (12) and then removing the 'V' band (9).

- Grip the flats visible on the main valve end and undo the lock-nut (7) clamping the diaphragm (10) and diaphragm plates (8). Please note: that when refitting the diaphragm plates the side with the radius should abut the diaphragm face.
- The diaphragm and diaphragm plates (8 and 10) can then be removed from the main valve which should be carefully lowered and removed via the valve inlet.

Note the diaphragm'O' ring seal (11) which sits against the diaphragm PTFE face on the wetted side.

- Reassemble in reverse order ensuring the PTFE (light colour) side of the two-part diaphragm is on the wetted side.

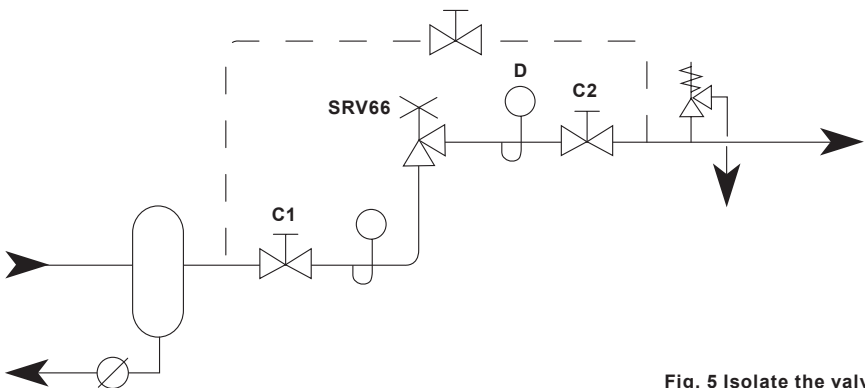

Fig. 5 Isolate the valve

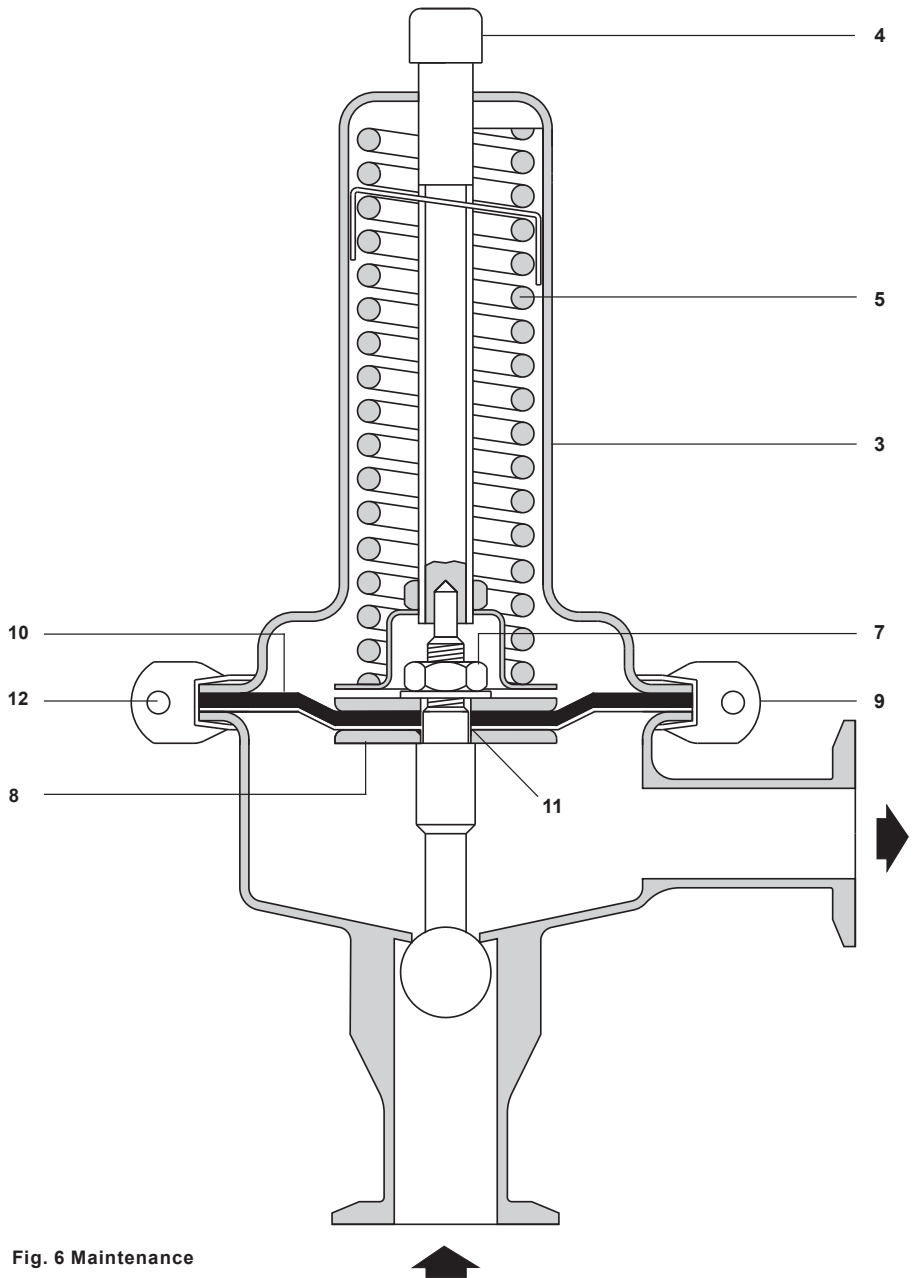

Fig. 6 Maintenance

SRV66 Sanitary Pressure Reducing Valve

7. Spare parts

The spare parts available are detailed below. No other parts are supplied as spares.

Available spares

Diaphragm and 'O' ring

10, 11

How to order spares

Always order spares by using the description given in the column headed 'Available spares' and state the size, model, pressure range and PN rating.

Example:

1 - Diaphragm and 'O' ring and gasket kit for a Spirax Sarco DN25 SRV66 direct acting pressure reducing valve having a pressure range of 1 to 5 bar, a PN10/PN6 rating and FPM diaphragm.

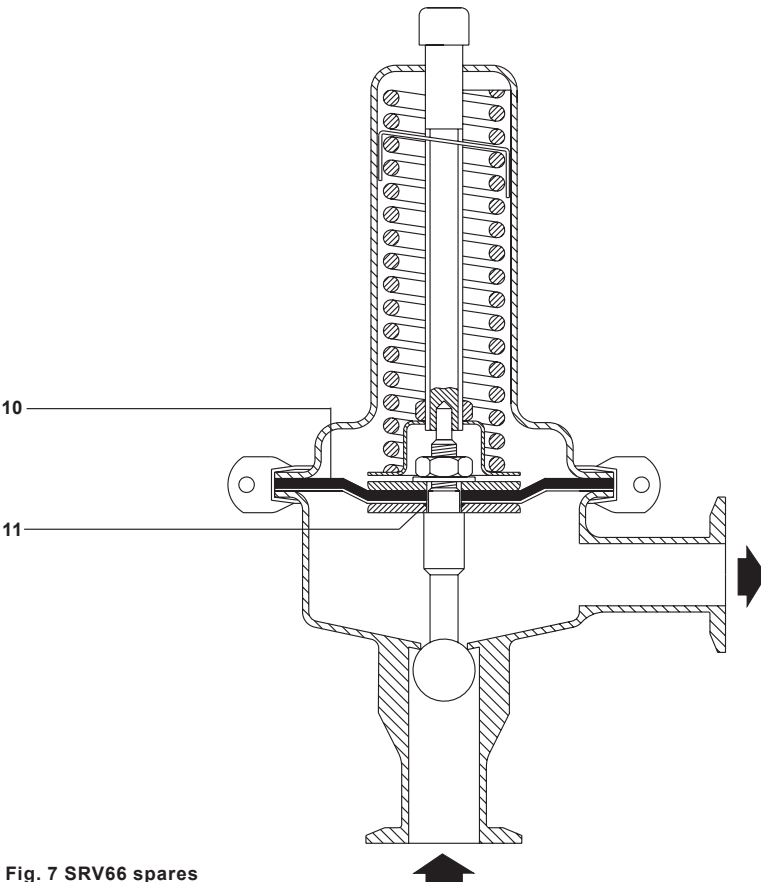

Fig. 7 SRV66 spares

SRV66 Sanitary Pressure Reducing Valve