

SP8-10
Smart positioner
Installation and Maintenance Instructions



1. Safety information

2. General product information

3. Installation

4. Commissioning

5. Operation

6. Troubleshooting

7. Maintenance

Copyright © Spirax-Sarco Limited 2021

All rights reserved

Spirax-Sarco Limited grants the legal user of this product (or device) the right to use the Work(s) solely within the scope of the legitimate operation of the product (or device). No other right is granted under this licence. In particular and without prejudice to the generality of the foregoing, the Work(s) may not be used, sold, licensed, transferred, copied or reproduced in whole or in part or in any manner or form other than as expressly granted here without the prior written consent of Spirax-Sarco Limited.

Contents

1. Safety information	4
2. General product information	
2.1 Introduction	7
2.2 Label description	
2.3 Operating principle	9
3. Installation	10
3.1 Mechanical mounting	
3.2 Electrical connections	21
3.3 Connection on the device	25
4. Commissioning	37
4.1 Checks prior to commissioning	
5. Operation	39
5.1 Parameterization of the device	
6. Troubleshooting	79
6.1 Diagnosis/error messages	
7. Maintenance	85

1. Safety information

Safe operation of these products can only be guaranteed if they are properly installed, commissioned, used and maintained by qualified personnel (see Section 1.13) in compliance with the operating instructions. General installation and safety instructions for pipeline and plant construction, as well as the proper use of tools and safety equipment must also be complied with.

1.1 Wiring

Every effort has been made during the design of the positioner to ensure the safety of the user, but the following precautions must be followed:

- i) Ensure correct installation. Safety may be compromised if the installation of the product is not carried out as specified in this manual.
- ii) Wiring should be carried out in accordance with IEC 60364 or equivalent.
- iii) Fuses should not be installed in the protective earth conductor. The integrity of the installation protective earth system must not be compromised by the disconnection or removal of other equipment.

1.2 Intended use

Referring to the Installation and Maintenance Instructions, product markings and Technical Information Sheet, check that the product is suitable for the intended use/application.

1.3 Access

Ensure safe access and if necessary a safe working platform (suitably guarded) before attempting to work on the product. Arrange suitable lifting gear if required.

1.4 Lighting

Ensure adequate lighting, particularly where detailed or intricate work is required.

1.5 Hazardous liquids or gases in the pipeline

Consider what is in the pipeline or what may have been in the pipeline at some previous time. Consider: flammable materials, substances hazardous to health, extremes of temperature.

1.6 Hazardous environment around the product

Consider: explosion risk areas, lack of oxygen (e.g. tanks, pits), dangerous gases, extremes of temperature, hot surfaces, fire hazard (e.g. during welding), excessive noise, moving machinery. The positioner is suitable for installation in Zone 1 or Zone 2 (Gas). The positioner shall not be used in zone 0.

1.7 The system

Consider the effect on the complete system of the work proposed. Will any proposed action (e.g. closing isolation valves, electrical isolation) put any other part of the system or any personnel at risk?

Dangers might include isolation of vents or protective devices or the rendering ineffective of controls or alarms. Ensure isolation valves are opened and closed progressively to avoid system shocks.

1.8 Pressure systems

Ensure that any pressure is isolated and safely vented to atmospheric pressure. Consider double isolation (double block and bleed) and the locking or labelling of closed valves. Do not assume that the system has depressurised even when the pressure gauge indicates zero.

1.9 Temperature

Allow time for temperature to normalise after isolation to avoid the danger of burns.

1.10 Tools and consumables

Before starting work ensure that you have suitable tools and /or consumables available. Use only genuine Spirax Sarco replacement parts.

1.11 Protective clothing

Consider whether you and /or others in the vicinity require any protective clothing to protect against the hazards of, for example, chemicals, high /low temperature, radiation, noise, falling objects, and dangers to eyes and face.

1.12 Permits to work

All work must be carried out or be supervised by a suitably competent person. Installation and operating personnel should be trained in the correct use of the product according to the Installation and Maintenance Instructions.

Where a formal 'permit to work' system is in force it must be complied with. Where there is no such system, it is recommended that a responsible person should know what work is going on and, where necessary, arrange to have an assistant whose primary responsibility is safety. Post 'warning notices' if necessary.

1.13 Handling

Manual handling of large and /or heavy products may present a risk of injury. Lifting, pushing, pulling, carrying or supporting a load by bodily force can cause injury particularly to the back. You are advised to assess the risks taking into account the task, the individual, the load and the working environment and use the appropriate handling method depending on the circumstances of the work being done.

1.14 Residual hazards

In normal use the external surface of the product may be hot. Many products are not self-draining. Take due care when dismantling or removing the product from an installation (refer to 'Maintenance instructions').

1.15 Freezing

Provision must be made to protect products which are not self-draining against frost damage in environments where they may be exposed to temperatures below freezing point.

1.16 Returning products

Customers and stockists are reminded that under EC Health, Safety and Environment Law, when returning products to Spirax Sarco they must provide information on any hazards and the precautions to be taken due to contamination residues or mechanical damage which may present a health, safety or environmental risk. This information must be provided in writing including Health and Safety data sheets relating to any substances identified as hazardous or potentially hazardous.

Product return procedure

Please provide the following information with any equipment being returned:

1. Your name, Company name, address and telephone number, order number and invoice and return delivery address.
2. Description of equipment being returned.
3. Description of the fault.
4. If the equipment is being returned under warranty, please indicate:
 - i. Date of purchase
 - ii. Original order number
 - iii. Serial number

Please return all items to your local Spirax Sarco branch.

Please ensure all items are suitably packed for transit (preferably in the original cartons).

2. General product information

2.1 Introduction

The SP8 is an electronically configurable positioner with communication capabilities designed for mounting on pneumatic linear or rotary actuators. It features a small and compact design, a modular construction, and an excellent cost-performance ratio. Fully automatic determination of the control parameters and adaptation to the positioner allow for considerable time savings as well as optimum control behaviour. The positioner has a built-in LCD indicator with a multi-line LCD display and 4 operating buttons for commissioning, configuration, and monitoring during live operation. Alternatively, the appropriate DTM/EDD can be used via the available communication interface. The positioner supports HART5 and HART7 communication. In addition to its input for the Analogue position set-point, the positioner is equipped with a digital input which can be used to activate a control system functions in the device.

2.2 Label description

- **Order-Code** Indicates the order code.
- **Serial no.** Indicates unique serial number
- **HW-Rev.** Indicates the hardware version
- **SW-Rev.** Indicates the software version.
- **DOM** Indicates the date of manufacture.
- **Special Request** Indicates any special requests.
- **Supply press.** Indicates the supply air pressure operating range.
- **Input** Indicates the Analogue input mA range.
- **Output** Indicates whether single or double acting.
- **Safe position** Indicates whether fail safe or fail freeze.



Options:

- **Pressure sensors** Indicates whether pressure sensors are installed.
- **Electr. limits switch** Indicates whether electr. limits switch is installed.
- **Mech. limits switch** Indicates whether Mech. limits switch is installed.
- **Contactless pos. sensor** Indicates whether contactless pos. sensor is installed.
- **Analogue feedback output** Indicates whether Analogue feedback output is installed.
- **Digital feedback output** Indicates whether digital feedback output is installed.
- **Universal Analogue Input** Indicates whether universal Analogue input is installed.
- **Safety shut down** Indicates whether safety shutdown is set.

Label example

 SP8-10	Order-Code: SP8-10-***** ***** Serial no.: 3K65 ***** HW-Rev.:*** SW-Rev.:*** DCM:*** Special Request: *****	Pressure sensors Electr. limit switch Mech. limit switch Contactless pos. sensor	<table border="0"> <tr><td> </td><td> </td></tr> <tr><td> </td><td> </td></tr> <tr><td> </td><td> </td></tr> <tr><td> </td><td> </td></tr> </table>																								
Supply press.: 0.14...1.0MPa / 20...145psi Input: analogue 4 - 20mA Output: ***** acting Safe position: fail ***	Options: Analogue feedback output Digital feedback output Universal analogue input Safety shut down	<table border="0"> <tr><td> </td><td>Slot 1</td><td>Slot 2</td></tr> <tr><td> </td><td> </td><td> </td></tr> <tr><td> </td><td> </td><td> </td></tr> <tr><td> </td><td> </td><td> </td></tr> </table>		Slot 1	Slot 2										<table border="0"> <tr><td> </td><td> </td><td> </td><td> </td></tr> <tr><td> </td><td> </td><td> </td><td> </td></tr> <tr><td> </td><td> </td><td> </td><td> </td></tr> </table>												
	Slot 1	Slot 2																									

UK
 CA
 IP65 C E

 for parameters see operating instructions/certificate

Spirax-Sarco Limited
 Cheltenham GL51 9NQ
 Made in Germany

2.3 Operating principle

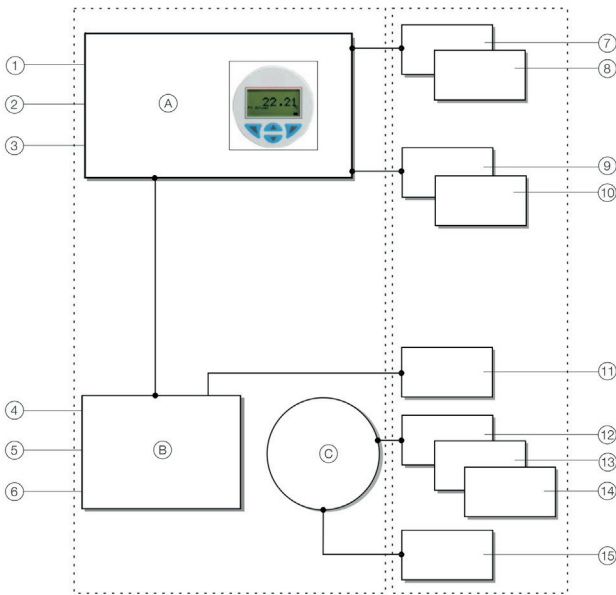

Fig. 1

- (A) Electronics
 (B) Pneumatics
 (C) Position sensor

1	4 to 20 mA/Bus connection
2	Digital input
3	Alarm output
4	Supply air
5	Output 1
6	Output 2
7	Analogue feedback
8	Digital feedback

9	Emergency shutdown module
10	Universal input
11	Pressure sensor
12	Limit alarm with 24 V micro-switch
13	Limit alarm with proximity switch (NC)
14	Limit alarm with proximity switch (NO)
15	Visual position indication

The SP8-10 is an electronically configurable positioner with communication capabilities designed for mounting on pneumatic linear or rotary actuators.

Fully automatic determination of the control parameters and adaptation to the positioner allow for considerable time savings as well as optimum control behavior.

3. Installation

3.1 Mechanical mounting

Arrow (1) on the device feedback shaft (position feedback) point must move between the arrow marks (2)

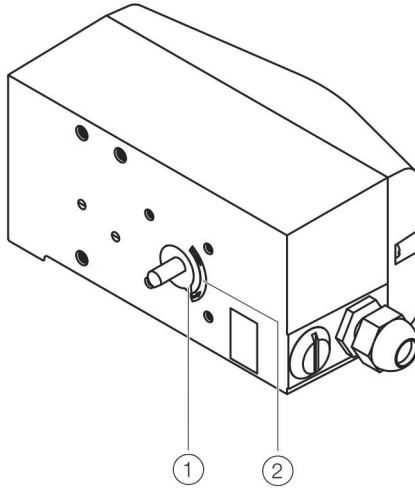

Fig. 2

3.1.1 Measuring and operating ranges of the positioner

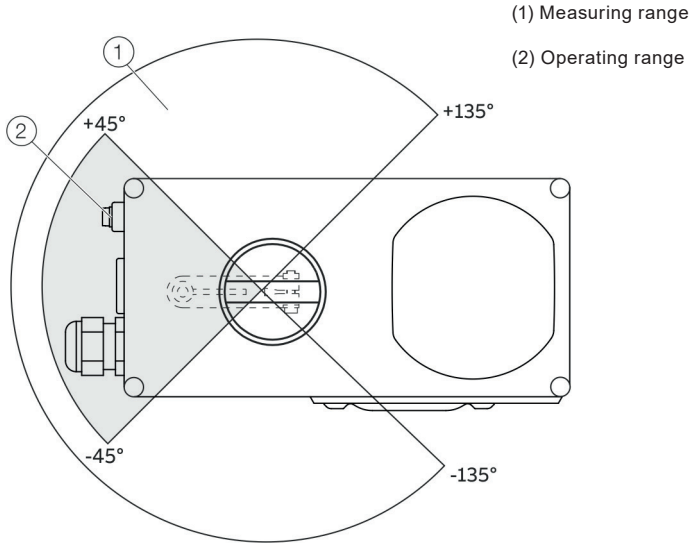

Fig. 3

Operating range for linear actuators:

The operating range for linear actuators is $\pm 45^\circ$ symmetrically to the longitudinal axis. The usable span within the operating range is at least 25° (recommended figure 40°). The usable span does not necessarily need to run symmetrically to the longitudinal axis.

Operating range of rotary actuators:

The usable span is 90° , which must be entirely within the measuring range, but does not necessarily need to run symmetrically to the longitudinal axis.

Note: During installation make sure that the actuator travel or rotation angle for position feedback is implemented correctly.

3.1.2 Mounting on linear actuators

For mounting on a linear actuator in accordance with IEC 534 (lateral mounting as per NAMUR), the following attachment kit is available:

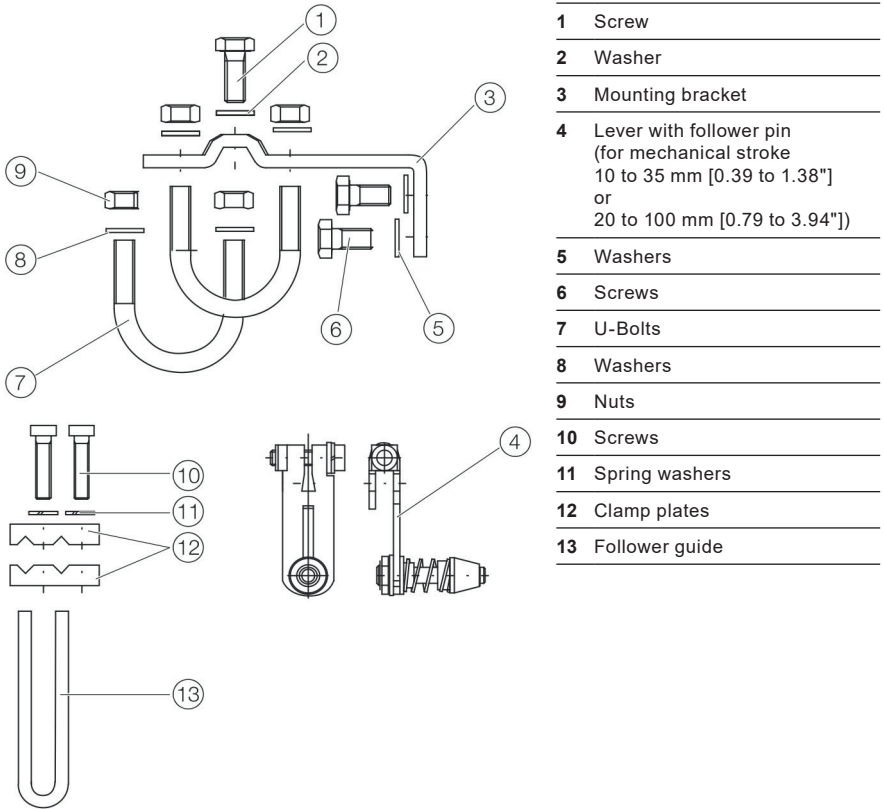

- | | |
|----|---|
| 1 | Screw |
| 2 | Washer |
| 3 | Mounting bracket |
| 4 | Lever with follower pin
(for mechanical stroke
10 to 35 mm [0.39 to 1.38"]
or
20 to 100 mm [0.79 to 3.94"]) |
| 5 | Washers |
| 6 | Screws |
| 7 | U-Bolts |
| 8 | Washers |
| 9 | Nuts |
| 10 | Screws |
| 11 | Spring washers |
| 12 | Clamp plates |
| 13 | Follower guide |

Fig. 4

3.1.3 Attaching a follower guide to the actuator

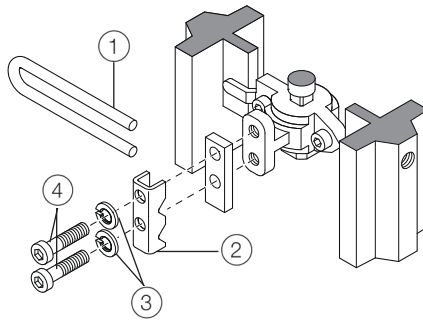

Fig. 5

1. Tighten the screws so that they are hand tight
2. Attach the follower guide (1) and clamp plates (2) with screws (4) and spring washers (3) to the actuator stem.

3.1.4 Mounting lever and bracket on the positioner

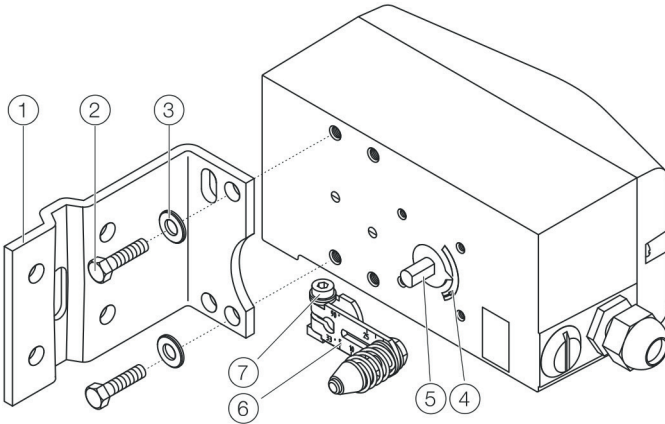

Fig. 6

1. Attach the lever (6) to the feedback shaft (5) of the positioner (can only be mounted in one position due to the cut shape of the feedback shaft).
2. Using the arrow marks (4), check whether the lever moves within the operating range (between the arrows).
3. Hand-tighten the screw (7) on the lever.
4. Hold the prepared positioner (with the mount bracket 1 still loose) on the actuator so that the follower pin for the lever enters the follower guide to determine which tap holes on the positioner must be used for the mount bracket. Positioner mounting threaded holes and bracket holes, depend on the actuator type used. Select to suit, to ensure the follower pin has free movement in the follower guide over entire valve travel.
5. Secure the mount bracket 1 with screws 2 and washers 3 using the relevant tap holes on the positioner housing. Positioner mounting threaded holes and bracket holes, depend on the actuator type used. Select to suit, to ensure the follower pin has free movement in the follower guide over entire valve travel.

Tighten the screws as evenly as possible to ensure subsequent linearity. Align the mount bracket in the oblong hole to ensure that the operating range is symmetrical. Set the valve mid stroke and align the lever horizontal (item 4 Fig. 7) then tighten mounting bolt (item 4 Fig. 10) (lever moves between the arrow marks Item 4 Fig. 9).

3.1.5 Mounting on a yoke

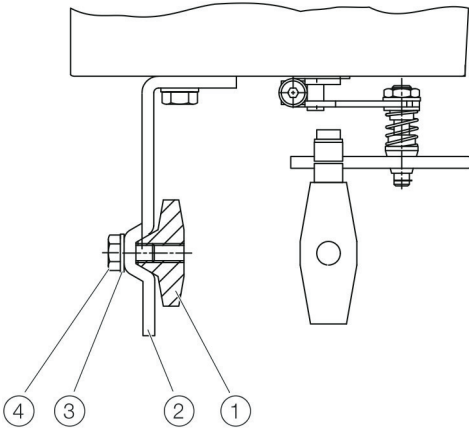

Fig. 7

1. Attach the mount bracket (2) with screw (4) and washer (3) to the yoke (1)

3.1.6 Mounting on a column

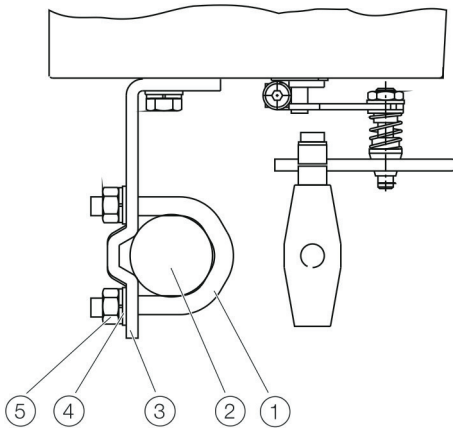

Fig. 8

1. Hold the mount bracket (3) in the proper position on the column (2).
2. Insert the U-bolts (1) from the inside of the column (2) through the holes of the mount bracket.
3. Add the washers (4) and nuts (5).
4. Tighten the nuts so that they are hand-tight.

Note: Adjust the height of the positioner on the yoke or column until the lever is horizontal (based on a visual check) at half stroke of the valve.

3.1.7 Positioner linkage

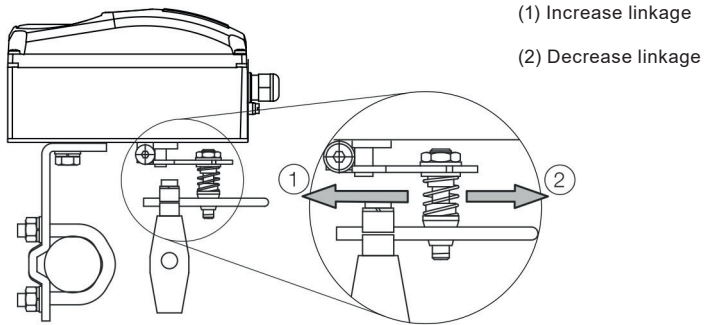

Fig. 9

The scale on the lever indicates the link points for the various stroke ranges of the valve.

Move the bolt with the follower pin in the oblong hole of the lever to adjust the stroke range of the valve to the working range for the position sensor.

Moving the link point inwards increases the rotation angle of the sensor. Moving the link point outwards reduces the rotation angle of the sensor.

Adjust the actuator stroke to make use of as large an angle of rotation as possible (symmetrical around the center position) on the position sensor.

Recommended range for linear actuators:	-28 to 28°
Minimum angle:	25°

Note: After mounting, check whether the positioner is operating within the measuring range.

3.1.8 Position of the actuator bolt

The actuator bolt for moving the potentiometer lever can be mounted permanently on the lever itself or on the valve stem. Depending on the mounting method, when the valve moves the actuator bolt performs either a circular or a linear movement with reference to the center of rotation of the potentiometer lever. Select the chosen bolt position in the HMI menu in order to ensure optimum linearisation. The default setting is actuator bolt on lever

3.1.9 Actuator bolts on the lever (Rear view)

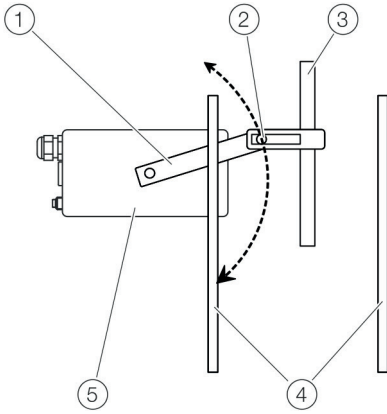

1 Potentiometer lever

2 Actuator bolts

3 Valve stem

4 Valve yoke

5 Positioner

Fig. 10

3.1.10 Actuator bolts on the Valve (Rear view)

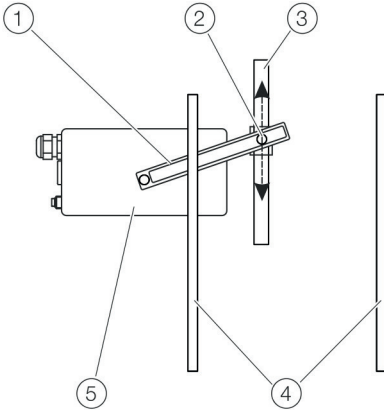

1 Potentiometer lever

2 Actuator bolts

3 Valve stem

4 Valve yoke

5 Positioner

Fig.11

3.1.11 Mounting on rotary actuator

For mounting on part-turn actuators in accordance with VDI/VDE 3845, the following attachment kit is available.

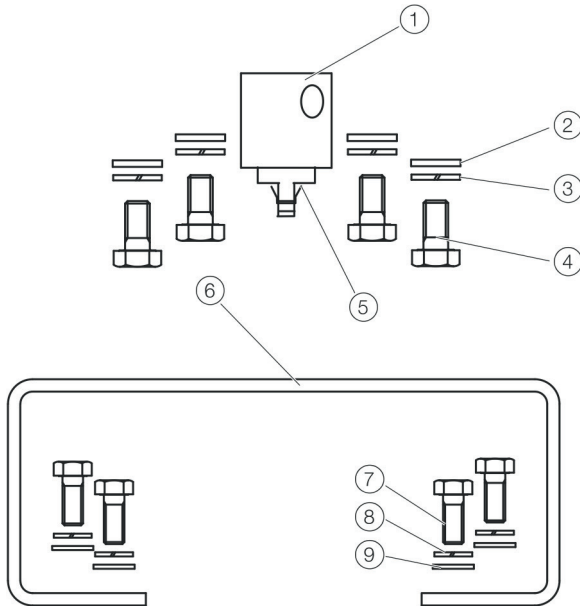

Fig.12 Components of attachment kit

- Adapter 1 with spring (5).
- Four M6 screws each (4), spring washers (3) and washers (2) to fasten the attachment bracket (6) to the positioner
- Four M5 screws (7), Spring washers (8) and washers (9) to fasten the attachment bracket to the actuator

Required tools:

- Wrench, size 8/10
- Allen key, size 3

3.1.12 Mounting the adapter on the positioner

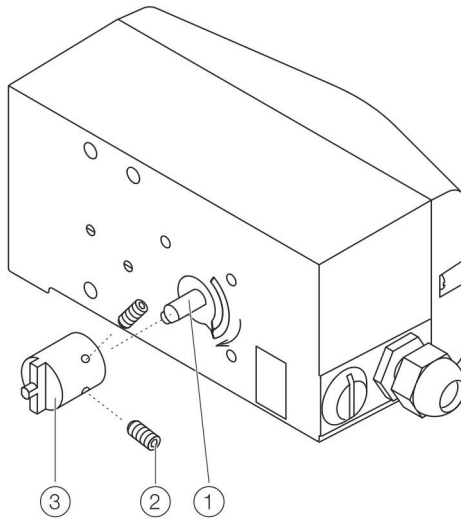

Fig.13

1. Determine the mounting position (parallel to actuator or at 90° angle)
2. Calculate the rotational direction of the actuator (right or left).
3. Move the part-turn actuator into the home position.
4. Pre-adjust feedback shaft.

To make sure that the positioner runs within the operating range (refer to General on page 14), the mounting position as well as the basic position and rotation direction of the actuator must be considered when determining the adapter position on axis (1). For this purpose, the feedback shaft can be adjusted manually so that the adapter (3) can be attached in the correct position.

5. Place the adapter in the proper position on the feedback shaft and fasten with threaded pins (2). One of the threaded pins must be locked in place on the flat side of the feedback shaft.

3.1.13 Screwing the attachment bracket onto the positioner

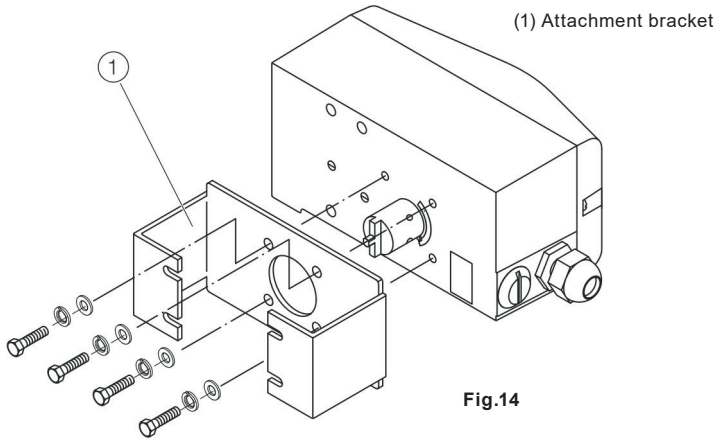

3.1.14 Screwing the positioner onto the actuator

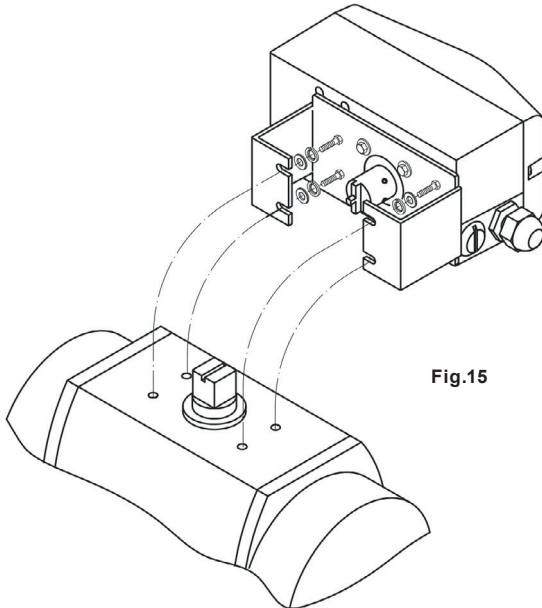

Note:

After mounting, check whether the operating range of the actuator matches the measuring range of the positioner, refer to General on page 10.

3.2 Electrical connections

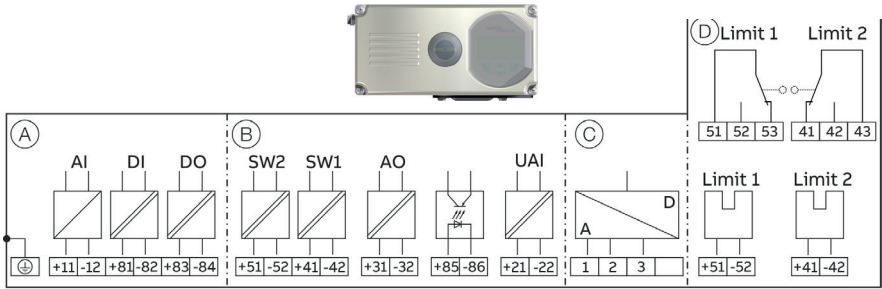

Fig.16

- A Basic device
- B Options
- C Connection SP8-10 Remote Sensor/remote position sensor (only for SP8-10 Control Unit version)
- D Options, limit monitor with proximity switches or micro-switches (not for SP8-10 Control Unit)

Connections for inputs and outputs

Terminal	Function/comments
+11/-12	Analogue input AI or field bus connection
+81/-82	Digital input DI
+83/-84	Digital output DO2
+51/-52	Limit alarm SW1 (Option module)
+41/-42	Limit alarm SW2 (Option module)
+31/-32	Analogue feedback AO (Option module)
+85/-86	Emergency shutdown module (Option module)
+21/-22	Universal input UAI
1/2/3	SP8-10 remote sensor (Only for options SP8-10 Remote Sensor or SP8-10 for remote position sensor)
+51/-52	Limit switch Limit 1 with proximity switch (optional)
+41/-42	Limit switch Limit 2 with proximity switch (optional)
51/52/53	Limit switch Limit 1 with micro-switch (optional)
41/42/43	Limit switch Limit 2 with micro-switch (optional)

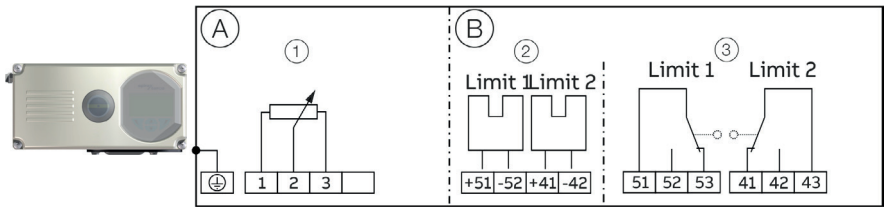

Fig.17

A Basic device

B Options

1 Position sensor

2 Limit monitor with proximity switches (optional)

3 Limit monitor with micro-switches (optional)

Connections for inputs and outputs

Terminal	Function/comments
1/2/3	SP8-10 Control Unit
+51/-52	Limit switch Limit 1 with proximity switch (optional)
+41/-42	Limit switch Limit 2 with proximity switch (optional)
51/52/53	Limit switch Limit 1 with micro-switch (optional)
41/42/43	Limit switch Limit 2 with micro-switch (optional)

3.2.1 Set point signal Analogue (two-wire technology)

Terminals	+11/-12
Nominal operating range	4 to 20 mA
Limit values	Maximum: 50 mA (overload) Minimum: 3.6 mA
Starting at	> 3.8 mA
Load voltage	9.7 V at 20 mA
Impedance	485 Ω at 20 mA

3.2.2 Digital input

Terminals	+81/-82
Supply voltage	24 Vdc (12 to 30 Vdc)
Input 'logical 0'	0 to 5 Vdc
Input 'logical 1'	11 to 30 Vdc
Input Current	Maximum 4 mA

3.2.3 Digital output DO

Terminals	+83/-84
Supply voltage	5 to 30 Vdc (Control circuit to DIN 19234/NAMUR)
Switching state logical	'0': current > 0.35 mA to < 1.2 mA '1': Current > 2,1 mA
Direction of action	standard logical '0' or logical '1' (configurable)

3.2.4 Module for Analogue feedback AO*

Without any signal from the positioner (e.g. 'no power' or 'initializing') the module sets the output to > 20 mA (alarm level).

Terminals	+31/-32
Signal range in the event of an error	4 to 20 mA (split ranges can be parameterized)
Supply voltage, two-wire technology	24 Vdc (11 to 30 Vdc)
Characteristic curve	rising or falling (configurable)
Deviation	< 1 %

3.2.5 Module for digital feedback SW1, SW2*

Two switches for binary position feedback (position adjustable within the range of 0 to 100 %, ranges cannot overlap)

Terminals	+41/-42, +51/-52
Supply voltage	5 to 11 Vdc (Control circuit to DIN 19234/NAMUR)
Signal current	< 1,2 mA: Switching state logical '0' > 2,1 mA: Switching state logical '1'
Direction of action	standard logical '0' or logical '1' (configurable)

3.2.6 Module for universal input UAI*

Module for a 4 to 20 mA input for universal use.

The range can be scaled. It is used for advanced valve diagnostics. For example, an ultrasonic sensor can be connected to detect a faulty valve seat or a phonometer can be connected to detect cavitation. The limit values for detecting up-scaling can be freely selected.

Terminals	+21/-22
Nominal operating range	4 to 20 mA
Load voltage	8 V at 20 mA
Impedance	400 Ω at 20 mA

3.2.7 Module for the emergency shutdown function*

When the 24 Vdc signal is interrupted, the I/P module executes the respective safety function, depending on the mechanical construction.

The positioner output 1 is depressurized, and the valve is moved to the safe position. In case of a double-acting actuator, output 2 is additionally pressurized.

The emergency shutdown module works independently of the mother board, i.e., all information from the final control element is available in the control system at any time.

Terminals	+85/-86
Supply voltage	24 Vdc (20 to 30 Vdc) (electrically isolated from the input signal)
Safe position	Active at < 5 Vdc

3.2.8 Limit switch

The limit switch can either be equipped with proximity switches or with potential-free micro-switches.

3.2.9 Limit switch Limit 1/Limit 2 with proximity switches

Two proximity switches for independent position signaling.

Terminals	+41/-42, +51/-52
Supply voltage	5 to 11 Vdc (Control circuit in accordance with DIN 19234/NAMUR)
Output 'logical 0'	< 1.2 mA
Output 'logical 1'	> 2.1 mA
Switching point	Adjustable between 0 and 100 %
Direction of action	Metal tag in proximity switch/Metal tag outside proximity switch
Type SJ2-SN (NC; log. 1)	< 1.2 mA/> 2.1 mA

3.2.10 Limit switch Limit 1/Limit 2 with 24 V micro-switches

Terminals	41/42/43, 51/52/53
Supply voltage	maximum 24 V AC/DC
Load rating	Maximum 2 A

3.3 Connection on the device

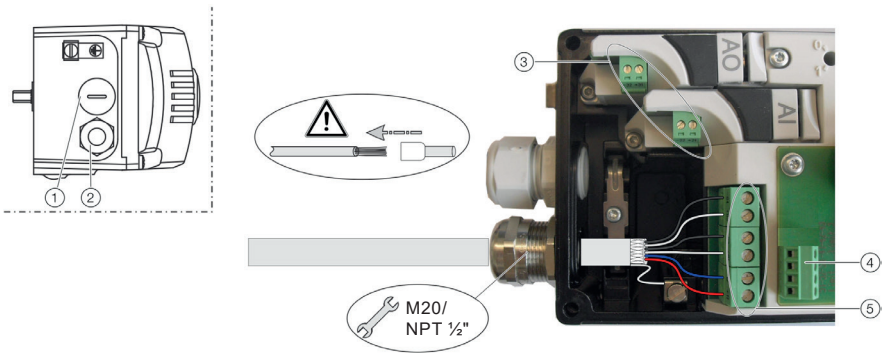

Fig. 18

- | | |
|---|--|
| 1 | Cable gland |
| 2 | Blind plug |
| 3 | Terminals for option modules |
| 4 | Terminal attachment kit for digital feedback |
| 5 | Terminals for basic unit |

2 tap holes $\frac{1}{2}$ 14 NPT or M20 \times 1.5 are provided on the left side of the housing for cable entry in the housing. One of the tap holes is fitted with a cable gland, while the other tap hole has a blind plug.

Note

The connecting terminals are delivered closed and must be unscrewed before inserting the wire.

1. Strip the wires to approximately 6 mm (0.24 in).
2. Connect the wires to the connecting terminals in line with the connection diagram.

3.3.1 Wire cross-sectional areas

Basic device - Electrical connections

4 to 20 mA input	Screw terminals max. 2.5 mm ² (AWG14)
Options	Screw terminals max. 1.0 mm ² (AWG18)

Cross section

Rigid/flexible wires	0.14 to 2.5 mm ² (AWG26 to AWG14)
Flexible with wire end sleeve	0.25 to 2.5 mm ² (AWG23 to AWG14)
Flexible with wire end sleeve no plastic sleeve	0.25 to 1.5 mm ² (AWG23 to AWG17)
Flexible with wire end sleeve with plastic sleeve	0.14 to 0.75 mm ² (AWG26 to AWG20)

Multi-wire connection capacity (two wire with the same cross-section)

Rigid/flexible wires	0.14 to 0.75 mm ² (AWG26 to AWG20)
Flexible with wire end sleeve no plastic sleeve	0.25 to 0.75 mm ² (AWG23 to AWG20)
Flexible with wire end sleeve with plastic sleeve	0.5 to 1.5 mm ² (AWG21 to AWG17)

3.3.2 Option modules

Cross section

Rigid/flexible wires	0.14 to 1.5 mm ² (AWG26 to AWG17)
Flexible with wire end sleeve no plastic sleeve	0.25 to 1.5 mm ² (AWG23 to AWG17)
Flexible with wire end sleeve with plastic sleeve	0.25 to 1.5 mm ² (AWG23 to AWG17)

Multi-wire connection capacity (two wire with the same cross-section)

Rigid/flexible wires	0.14 to 0.75 mm ² (AWG26 to AWG20)
Flexible with wire end sleeve no plastic sleeve	0.25 to 0.5 mm ² (AWG23 to AWG22)
Flexible with wire end sleeve with plastic sleeve	0.5 to 1 mm ² (AWG21 to AWG18)

Limit switch with proximity switches or 24 V micro-switches

Rigid wire	0.14 to 1.5 mm ² (AWG26 to AWG17)
Flexible wire	0.14 to 1.0 mm ² (AWG26 to AWG18)
Flexible with wire end sleeve no plastic sleeve	0.25 to 0.5 mm ² (AWG23 to AWG22)
Flexible with wire end sleeve with plastic sleeve	0.25 to 0.5 mm ² (AWG23 to AWG22)

3.3.3

Connection to device - SP8-10 Control Unit with SP8-10 Remote Sensor

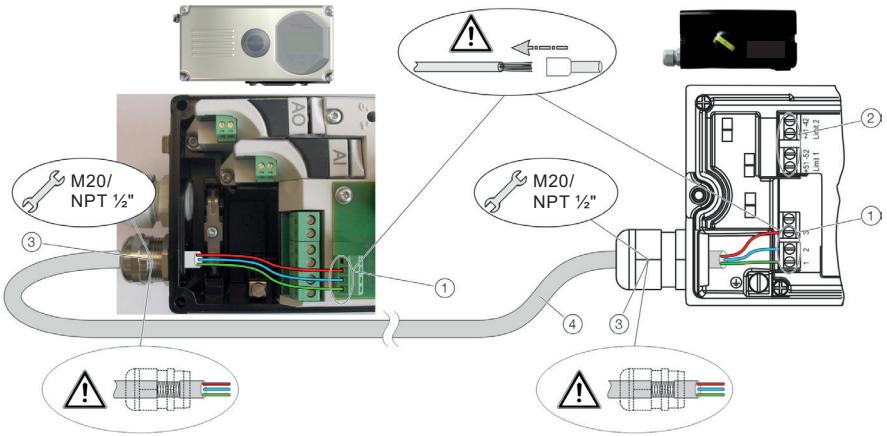

Fig.19

- | | |
|---|--|
| 1 | Terminals SP8-10 Remote Sensor |
| 2 | Terminal attachment kit for digital feedback |
| 3 | EMC Cable gland |
| 4 | Shielded connection cable |

In the case of the 'SP8-10 Control Unit with SP8-10 Remote Sensor' design, the components are supplied in two housings, which together form one harmonized unit. Housing 1 (SP8-10 Control Unit) contains the electronics and pneumatics along with the following optional modules (where applicable):

- | | |
|---|----------------------------|
| - | Analogue position feedback |
| - | Digital position feedback |
| - | Emergency shutdown module |
| - | Universal input |

Housing 2 (SP8-10 Remote Sensor) contains the position sensor and is suitable for mounting on linear or rotary actuators.

If necessary, the following options can be installed if required:

- | | |
|---|--|
| - | Optical position indicator |
| - | Mechanical feedback contacts designed as proximity switches or micro-switches. |

The housings of the SP8-10 Control Unit and the SP8-10 Remote Sensor are available in stainless steel as an option.

Cable specification

To connect the SP8-10 Remote Sensor, a cable with the following specifications needs to be used:

- | | |
|---|--|
| - | 3-wire, cross-section 0.5 to 1.0 mm ² |
| - | Shielded, with at least 85 % coverage |
| - | Temperature range up to at least 100 °C (212 °F) |

The cable glands used must also be approved for a temperature range up to at least 100 °C (212 °F). The cable glands require a mounting for the shielding and strain relief for the cable in addition.

Spirax-Sarco offers suited cables and cable glands with DNV_GL certification for the SP8-10 Remote Version.

3.3.4 Electrical Connection

Connect the positioner (SP8-10 Control Unit, housing 1) and remote position sensor (SP8-10 Remote Sensor, housing 2), while following the instructions below:

- The SP8-10 Remote Sensor and the SP8-10 Control Unit are adjusted to each other. Ensure that only devices with the same serial number are connected.
- A shielded 3-wire cable with a maximum length of 10 m (33 ft) must be used for the connection.
- Route the cable into the terminal compartment through the EMC cable glands. Ensure that the shielding is secured correctly in the EMC cable glands.
- Connect the cables in accordance with the electrical connections and tighten the screws of the terminals so that they are hand-tight.
- Use wire end ferrules when connecting.
- The electrical connections of the SP8-10 Control Unit and the optional modules are carried out as described in chapter Connection on the device on page 36.
- If the SP8-10 Control Unit is fastened so that it is non-conductive, the housing must be grounded (SP8-10 Control Unit and SP8-10 Remote Sensor housing with the same electric potential); otherwise control deviations could occur with regard to Analogue position feedback.
- In the SP8-10 Remote Sensor in IP rating IP 66, pre-tighten the cover screws by applying [approx. 50 Ncm (0.44 lbf-in) cross-wise and then tighten by applying 200 Ncm (1.77 lbf-in).
- The pneumatic outputs to the actuator must be connected using pneumatic lines with a minimum diameter of 6 mm.

3.3.5

Connection to device - SP8-10 Control Unit for remote position sensor

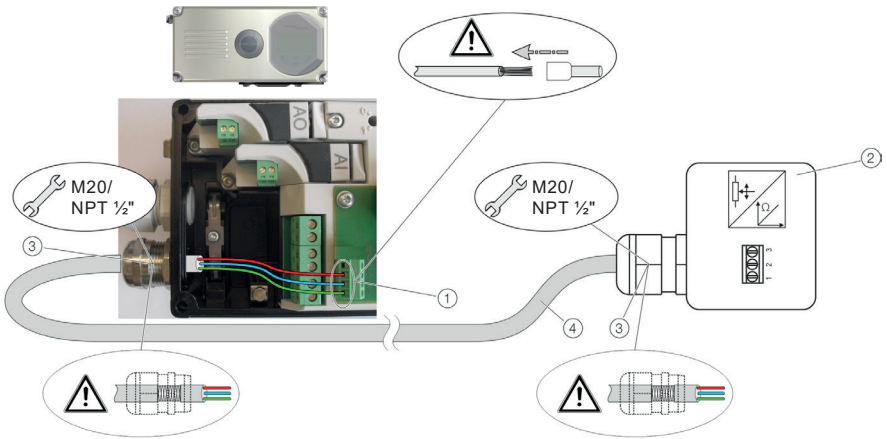

Fig.20

-
- | | |
|---|--------------------------------------|
| 1 | Terminals for remote position sensor |
| 2 | Remote position sensor |
| 3 | EMC Cable gland |
| 4 | Shielded connection cable |
-

With the SP8-10 designed for remote position sensors, the positioner is supplied without a position sensor.

The SP8-10 Control Unit contains the electronics and pneumatics along with the following options (where applicable):

- Analogue position feedback
- Digital position feedback
- Emergency shutdown module
- Universal input

Any position sensor (4 to 80 k Ω) may be connected.

3.3.6 Cable specification

To connect the SP8-10 Remote Sensor, a cable with the following specifications needs to be used:

- 3-wire, cross-section 0.5 to 1.0 mm²
- Shielded, with at least 85 % coverage
- Temperature range up to at least 100 °C (212 °F)

The cable glands used must also be approved for a temperature range up to at least 100 °C (212 °F). The cable glands require a mounting for the shielding and strain relief for the cable in addition. Spirax-Sarco offers suited cables and cable glands with DNV_GL certification for the SP8-10 Remote Version.

3.3.7 Electrical connection

Connect the positioner (SP8-10 Control Unit) and remote position sensor while observing the following instructions:

- A shielded 3-wire cable with a maximum length of 10 m (33 ft) must be used for the connection.
- Route the cable into the terminal compartment through the EMC cable glands. Ensure that the shielding is secured correctly in the EMC cable glands.
- Connect the cables in accordance with the electrical connections and tighten the screws of the terminals so that they are hand-tight.
- The electrical connections of the SP8-10 Control Unit and the optional modules are carried out as described in chapter Connection on the device on page 36.
- Use wire end ferrules when connecting.
- If the SP8-10 Control Unit is fastened so that it is non-conductive, the housing must be grounded (SP8-10 Control Unit and remote position sensor with the same electric potential); otherwise control deviations could occur with regard to Analogue position feedback.
- If the device is being operated on a cylinder, for reasons associated with linearity you should run automatic adjustment for the rotary actuator.
- The pneumatic outputs to the actuator must be connected using pneumatic lines with a minimum diameter of 6 mm.

3.3.8 Installing the option modules

Installing the mechanical position feedback

1. Loosen the screws for the housing cover and remove it.
2. If one has been installed, remove the optical position indication and unscrew the shaft extension.
3. Move the printed circuit board for position feedback to the right underneath the two plastic clips and secure it using the screw provided.
4. If applicable, install the optical position indication.
5. Attach the housing cover and screw it on to the housing. Tighten the screws so that they are hand-tight.

3.3.9 Installing the pressure option

Note:

- The supply voltage must be switched off before the pressure option is installed.
- The bonding wires for the pressure option must not be touched. Doing so will cause damage to the option module.
- Before using the device, a high-voltage test in accordance with IEC must be performed.

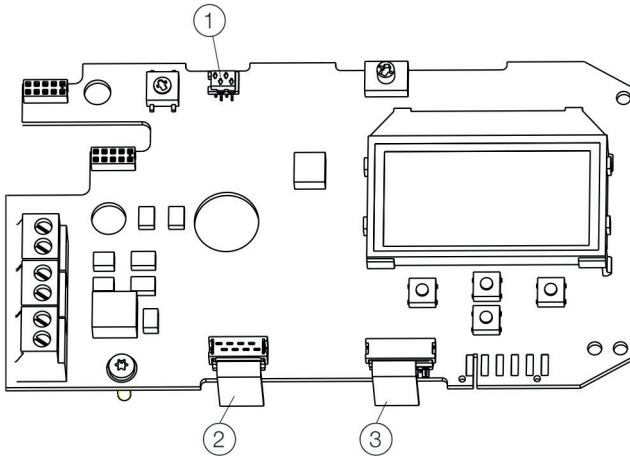

Fig.21

1 I/P converter pneumatic system

2 Position sensor

3 Pressure option

3.3.10 Installing option modules

1. Loosen the screws for the housing cover and remove it.
2. Loosen all cable connections on the screw terminals.
3. If present, unscrew the option modules and remove them from the side.
4. If present, remove the mechanical position indication and screw off the shaft extension (as well as the mechanical alarm signalling unit if applicable).
5. Remove the screws for the plastic cover and remove the cover.
6. Remove both plug connectors from the printed circuit board.
7. Unscrew the fixing screws for the printed circuit board and carefully remove the printed circuit board.
8. Unscrew the screws on the upper side of the pneumatics and remove the cover plate.
9. Carefully attach the pressure option to the pneumatics and screw it in place so that the screws are hand-tight.
10. Install the printed circuit board.
11. Attach both plug connectors (1), (2) to the printed circuit board (see Figure 25).
12. Attach the plug connectors for the pressure option (3) to the printed circuit board (see Figure 25).
13. Attach the plastic cap.
14. If necessary, install option modules and set the mechanical feedback.
15. Attach the housing cover and screw it on to the housing. Tighten the screws so that they are hand-tight.

3.3.11 Setting the option modules

Setting the mechanical position indication:

1. Loosen the screws for the housing cover and remove it.
2. Rotate the position indicator on the shaft to the desired position.
3. Attach the housing cover and screw it onto the housing. Tighten the screws so that they are hand-tight.
4. Attach the symbol label to mark the minimum and maximum valve positions on the housing cover.

Note: The labels are located on the inside of the housing cover.

3.3.12 Setting the mechanical limit switch with proximity switches

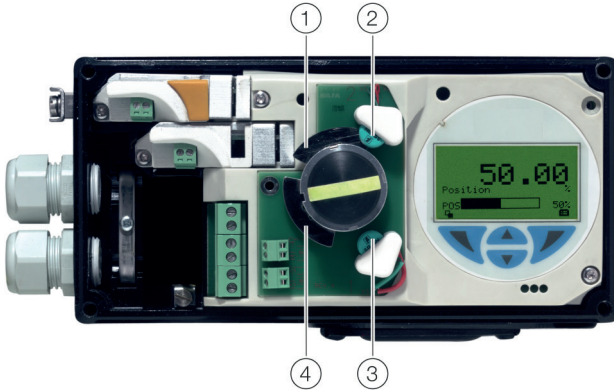

Fig.22

-
- | | |
|---|--------------------------|
| 1 | Upper metal tag |
| 2 | Proximity switch Limit 2 |
| 3 | Proximity switch Limit 1 |
| 4 | Lower metal tag |
-

1. Loosen the screws for the housing cover and remove it.
2. Set the upper and lower switching points for binary feedback as follows:
3. Select the 'Manual Adjustment' operating mode and move the final control element by hand into the lower switching position.
4. Using a screwdriver, adjust the metal tag of proximity switch 1 (lower contact) on the axis until contact is made, i. e., just before it is inserted in the proximity switch. The slot sensor enters proximity switch 1 when the feedback shaft is rotated clockwise (as viewed from the front).
5. Move the final control element by hand into the upper switching position.
6. Using a screwdriver, adjust the metal tag of proximity switch 2 (upper contact) on the axis until contact is made, i. e., just before it is inserted in the proximity switch. The slot sensor enters proximity switch 2 when the feedback shaft is rotated counter-clockwise (as viewed from the front).
7. Attach the housing cover and screw it onto the housing.
8. Tighten the screws so that they are hand-tight.

3.3.13 Setting the mechanical limit switch with 24 V micro-switches

1. Loosen the screws for the housing cover and remove it.
2. Select the 'Manual Adjustment' operating mode and move the final control element by hand into the desired switching position for contact 1.
3. Set maximum contact (1, lower washer).
Fasten the upper washer with the special adjustment retainer and rotate the lower washer manually.
4. Select the 'Manual Adjustment' operating mode and move the final control element by hand into the desired switching position for contact 2.
5. Set minimum contact (2, upper washer);
Fasten the lower washer with the special adjustment retainer and rotate the upper washer manually.
6. Connect the micro-switch.
7. Attach the housing cover and screw it on to the housing.
8. Tighten the screws so that they are hand-tight.

3.3.14 Pneumatic connections

Notes:

- The positioner must only be supplied with instrument air that is free of oil, water, and dust.
- The purity and oil content must meet the requirements of Class 3:3:3 in accordance with ISO 8573-1.

Notice

Damage to components! Contamination on the air pipe and positioner can damage components.

- Dust, splinters, and any other particles of dirt must be blown-out before the pipe is connected. Pressure above 6 bar (90 psi) can damage the positioner or actuator.
- Provisions must be made (e.g., by using a pressure reducer) to make sure that the pressure does not rise above 6 bar (90 psi)*, even in the event of a fault.

Information on double acting actuators with spring-return mechanism

On double-acting actuators with spring-return mechanism, a pressure that significantly exceeds the supply air pressure value can be generated during operation by the springs in the chamber opposite the springs.

This may damage the positioner or adversely affect control of the actuator.

To eliminate the possibility of this occurring, it is recommended to install a pressure compensation valve between the spring less chamber and the supply air for these types of applications. It enables the increased pressure to be transferred back to the air inlet line.

The opening pressure of the check valve should be < 250 mbar (< 3.6 psi).

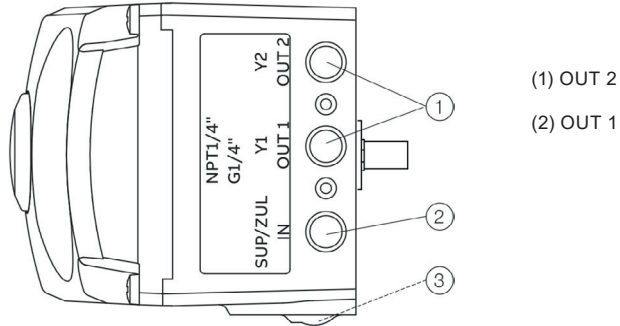

Fig.23

Marking	Pipe connection
IN	Supply air, pressure 1.4 to 10 bar (20 to 145 psi)
OUT1	Output pressure to the actuator
OUT2	Output pressure to the actuator (2. Connection with double acting actuator)

Join the pipe connections according to the designation, observing the following points:

- All pneumatic piping connections are located on the right-hand side of the positioner. ¼ 18 NPT tapped holes are provided for the pneumatic connections. The positioner is labeled according to the tap holes available.
- We recommend that you use a pipe with dimensions of 12 × 1.75 mm.
- The supply air pressure required to apply the actuating force must be adjusted in line with the output pressure in the actuator. The operating range of the positioner is between 1.4 to 6 bar (20 to 90 psi)***.

3.3.15 Pneumatic connections - Air supply

Instrument air*

Purity	Maximum particle size: 5 µm Maximum particle density: 5 mg/m ³
Oil content	Maximum concentration 1 mg/m ³
Pressure dew point	10 K below operating temperature
Supply pressure**	Standard design: 1.4 to 6 bar (20 to 90 psi)
Air consumption***	< 0.03 kg/h/0.015 scfm

* Free of oil, water and dust in accordance with DIN/ISO 8573-1. Pollution and oil content in accordance with Class 3:3:3

** Do not exceed the maximum output pressure of the actuator

*** Independent of supply pressure

3.3.16 Compressed air output

Range	0 to 10 bar (0 to 145 psi)
Air capacity	Standard: 40 kg/h (31 Nm ³ /h/20 scfm) Optional: 50 kg/h (40 Nm ³ /h/23 scfm)
Output function	For single acting or double acting actuators Air is vented from actuator or actuator is blocked in case of (electrical) power failure
Shut-off values	End position 0 % = 0 to 45 % End position 100 % = 55 to 100 %

4. Commissioning

4.1 Checks prior to commissioning

Air pressure in the compressed air connecting line:

- 1.4 to 10 bar (20 to 145 psi)

Current input active: 4 to 20 mA

4.1.1 Mechanical mounting checks



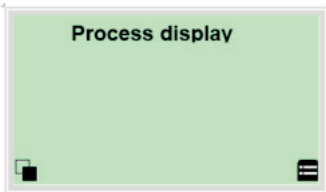

During commissioning, the mechanical mounting on the linear and rotary actuators is checked. For this purpose, the actuator is first moved into the end positions and Auto Adjust is then carried out. With large actuators, it can occur that the time for automatic adjustment is significantly than in smaller actuators.

Moving to end positions after completion of automatic adjustment

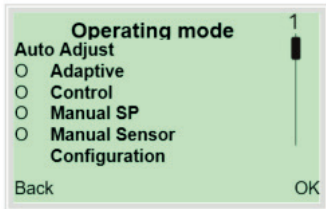

1. Use  to switch to the operating mode menu.



2. Use  or  to select the 'Manual sensor' operating mode.
3. Use  and  to move to the relevant end positions.

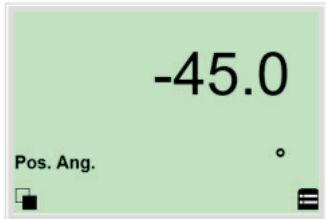



Check the end positions. The angle of rotation is displayed in degrees.

Recommended range

- Between -30 to 30° for linear actuator
- Between -45 to 45° for rotary actuator

Moving to end positions with a new device



1. Use  and  to move to the relevant end positions.



Check the end positions. The angle of rotation is displayed in degrees.

Recommended range

- Between -30 to 30° for linear actuator
- Between -45 to 45° for rotary actuator

Auto adjust must then be performed.

5. Operation

5.1 Parameterization of the device

The LCD display features operating buttons which enable the device to be operated with the housing cover open.

5.1.1 Menu navigation

- | | |
|---|--|
| 1 | Operating buttons for menu navigation |
| 2 | Indication of menu designation |
| 3 | Indication of menu number |
| 4 | Marking to indicate relative position within the menu |
| 5 | Indication of the current function assigned to the operating buttons |

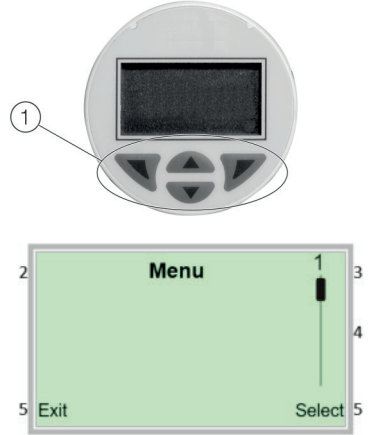

Fig.24

You can use the UP or DOWN operating buttons to browse through the menu or select a number or character within a parameter value.

Different functions can be assigned to the LEFT and RIGHT operating buttons. The function that is currently assigned 5 is shown on the LCD display.

Left operating button	Meaning
Exit	Exit menu
Back	Go back one submenu
Cancel	Cancel parameter entry
Next	Select the next position for entering numerical and alphanumeric values

Right operating button	Meaning
Select	Select submenu/parameter
Edit	Edit parameter
OK	Save parameter enter

5.1.2 Menu levels

There are three menu levels below the process display.

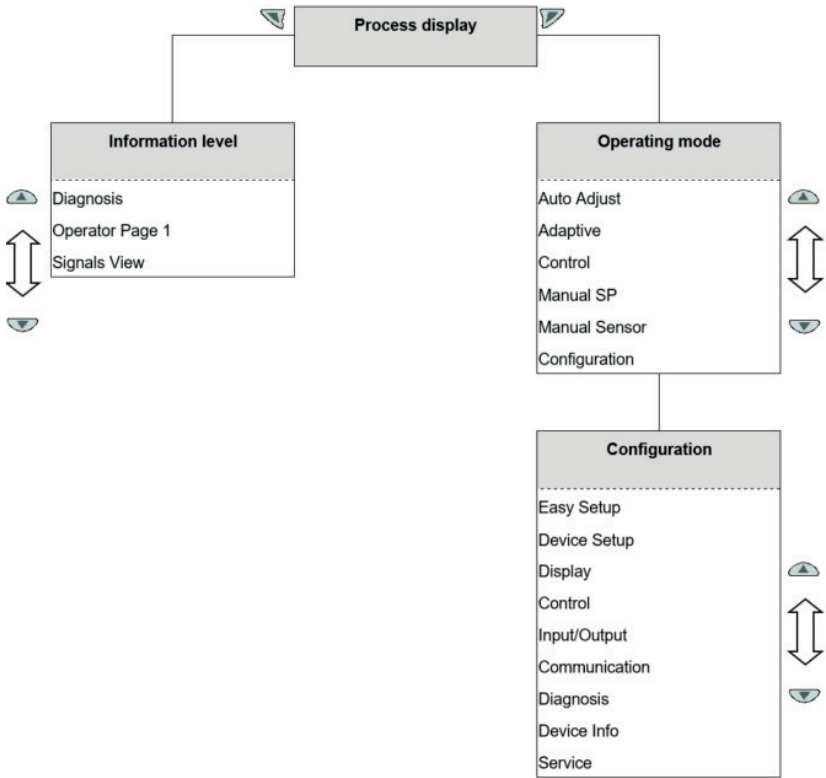

Fig.25

Process display	The process display shows the current process values.
Information level	The information level contains the parameters and information that are relevant for the operator. The device configuration cannot be changed on this level.
Operating modes menu	In the operating modes menu, the Auto Adjust function can be started for commissioning purposes. You can also change the operating modes and switch to the configuration level.
Configuration level	The configuration-, parameterization instruction contains all the parameters required for device commissioning and configuration. The device configuration can be changed on this level.

5.1.3 Process display

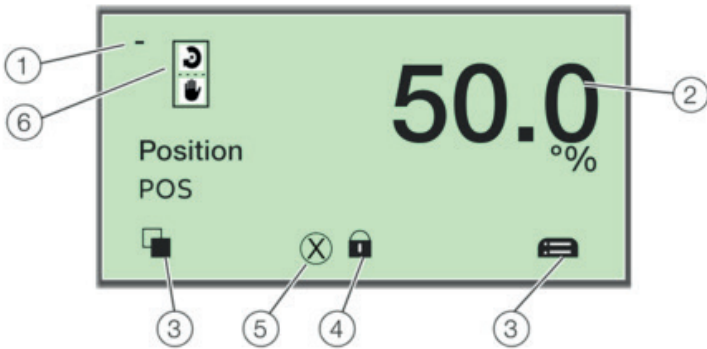





Fig.26

- | | |
|---|--|
| 1 | Indication of measuring point tagging |
| 2 | Indication of current process values |
| 3 | Symbol indicating button function |
| 4 | Symbol indicating 'Parameterization protected' |
| 5 | Diagnosis notice |
| 6 | Operating mode symbol |





The process display appears on the LCD display when the device is powered on. It shows information about the device and current process values.

The way in which the current process values (2) are shown can be adjusted on the configuration level.

5.1.4 Description of symbols

Symbol	Description
	Call up information level. When Auto scroll mode is enabled, a symbol appears and the operator pages are automatically displayed one after the other
	Call up configuration level
	The device is protected against changes in the parametrization

5.1.5 Description of the message symbols

Symbol	Message symbol
	Universal input activated
	Diagnostic message pending
	Error pending
	Maintenance message pending

5.1.6 Switching to the information level (Operator Menu)

On the information level, the operator menu can be used to display diagnostic information and choose which operator pages to display.



1. Use **LEFT** to go to the information level

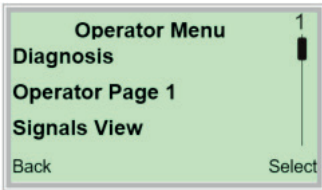

2. Use **UP** or **DOWN** select a submenu.
3. Confirm the selection with **RIGHT**

Menu	Description
Diagnosis	Displays the alarms and messages that are currently pending and which occurred in the past. The messages to be displayed can be selected on the configuration level, under 'Diagnosis'.
Operator Page 1	Switches to the process display.
Signals View	Selection of submenu 'Signals View' (only for service purposes). The following signal values (plus units) can be displayed: <ul style="list-style-type: none"> - Position - Pos[%] - Position - Pos[°] - Set point - SP[%] - Set point - SP[mA] - Control deviation - DEV [%] - Electronic unit temperature [°C, °F, °R, K] - Supply pressure - PIN [unit] - Pressure output 1 - PY1 [unit] - Pressure output 2 - PY2 [unit] - Differential pressure - DP [unit] - Universal input value - UIN [unit]

5.1.7 Switching the operating mode

The operating mode is displayed and changed in the operating modes menu. Additionally, it is possible to switch to the configuration level from there.

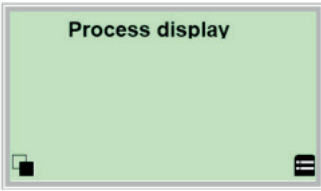



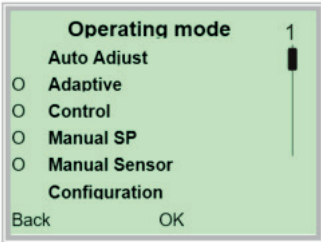



1. Use **RIGHT** to switch to the Operating Mode menu

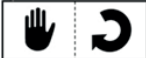

2. Use **UP** or **DOWN** to select the required operating mode.
3. Confirm the selection with **RIGHT**

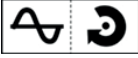
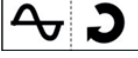
5.1.8 Description of operating modes

SYMBOL	OPERATING MODE
	<p>Adaptive control active When the SP8-10 positioner is operated in 'Adaptive Mode', the control parameters are automatically optimized to the operating conditions in small increments. This is especially helpful if valves and fittings could not be operated with reference conditions while the Auto Adjust function was in progress. The long-term stability of the adaptive operating mode results more from the system structure than from the changing behavior of the system, meaning that if a stable, adaptive operating mode can be obtained over several days of control variations in the system application with positioner, actuator, valve and changes in behavior, we can assume stable operation in the application mentioned above. If that is not the case, the 'Non-adaptive control' option should be selected.</p>
	<p>Fixed control In contrast to the 'Adaptive control' operating mode, the control parameters are not automatically adjusted.</p>
	<p>Manual set point, adaptive control The valve is adjusted manually within the stroke range using the UP or DOWN direction buttons.</p> <ol style="list-style-type: none"> 1. Press and hold the relevant operating button for the desired direction 2. Additionally, press LEFT if the device is to be switched to high-speed mode.
	<p>Manual set point, fixed control The valve is adjusted manually within the stroke range using the UP or DOWN direction buttons.</p> <ol style="list-style-type: none"> 1. Press and hold the relevant operating button for the desired direction 2. Additionally, press LEFT if the device is to be switched to high-speed mode.
	<p>Moving the actuator manually The valve is adjusted manually within the valve range using the UP or DOWN direction buttons. The position indicator shows the position in angular degrees for the purpose of checking the mounting conditions.</p> <ol style="list-style-type: none"> 1. Press and hold the relevant operating button for the desired direction 2. Additionally, press LEFT if the device is to be switched to high-speed mode.
	Set point via HART, adaptive control
	Set point via HART, fixed control
	Activated binary input, adaptive control
	Activated binary input, fixed control

5.1.9 Start automatic adjustment

The Auto Adjust function of the device can be configured and started in the 'Operating mode' menu.



1. Use **RIGHT** to switch to the operating mode menu

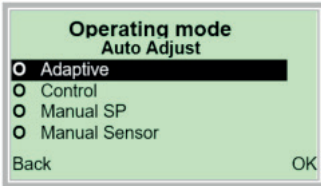

2. Use **UP** or **DOWN** to select the 'Adaptive' operating mode.
3. Confirm the selection with **RIGHT**. Press and hold down the control button for at least 4 seconds (wait for the time to count down on the top left of the display).

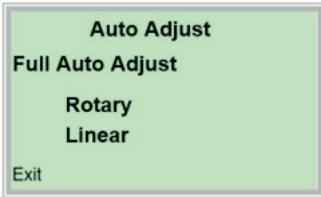

4. Use **UP** or **DOWN** to select 'Actuator type'.
Select 'Rotary' for rotary actuators.
Select 'Linear' for linear actuators.

5.1.10 Switching the operating mode

Note:

The 'Auto adjust Mode' can be pre-set at the configuration level in '.../Easy Setup/Auto adjust Mode'.

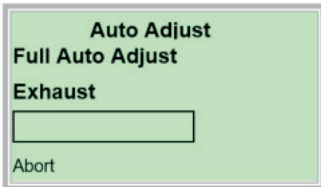

The progress of the Auto Adjust function is shown in a bar graph. The function can be terminated with 'Abort' if necessary. Once Auto Adjust has been completed successfully, 'Auto Adjust Complete' is displayed. The device then switches to the process display automatically.

Note:

Auto Adjust does not always result in optimum control conditions. When Auto Adjust is started via shortcut keys, the position of the valve is determined automatically.

5.1.11 Switching to the configuration level (parameterization)

The device parameters can be displayed and changed on the configuration level.

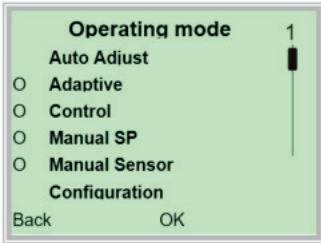

5. Use **UP** or **DOWN** to select the 'Configuration' operating mode.
6. Confirm the selection with **RIGHT**

5.1.12 Selecting and changing parameters tabular entry

When an entry is made from a table, a value is selected from a list of parameter values.

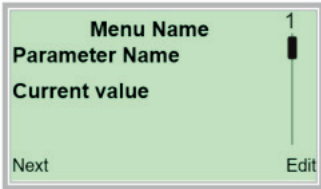

1. Select the parameters you want to set in the menu.
2. Use **RIGHT** to call up the list of available parameter values. The parameter value that is currently set is highlighted.

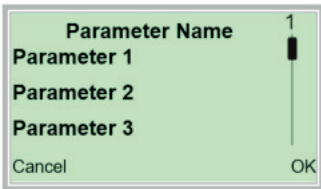

3. Use **UP** or **DOWN** to select the desired value.
4. Confirm the selection with **RIGHT**.

This concludes the procedure for changing a parameter value.

5.1.13 Numerical entry

When a numerical entry is made, a value is set by entering the individual decimal positions.

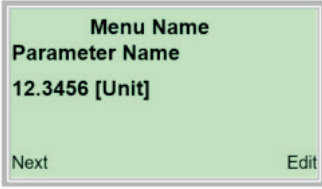

Menu Name
Parameter Name
12.3456 [Unit]
Next Edit

1. Select the parameters you want to set in the menu.
2. Use **RIGHT** to call up the parameter for editing. The decimal place that is currently selected is highlighted.

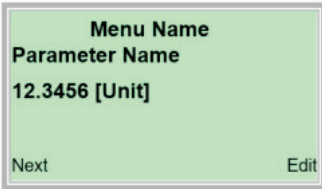

Menu Name
Parameter Name
12.3456 [Unit]
Next Edit

3. Use **LEFT** to select the next decimal place to change.
4. Use **UP** or **DOWN** to set the desired value.
5. Use **LEFT** to select the next decimal place.
6. Select and set additional decimal places as needed in accordance with steps 3 to 4.
7. Use **RIGHT** to confirm your setting





This concludes the procedure for changing a parameter value.

5.1.14 Error messages on the LCD display

In the event of an error, a message consisting of a symbol and text appears at the bottom of the process screen (e. g. electronics) the text displayed provides information about the area in which the error has occurred.



The error messages are divided into four groups in accordance with the NAMUR classification scheme. The group assignment can only be changed using a DTM or EDD:

Symbol	Fault message	Description
	Failure	Errors
	Fcheck	Check for errors
	OOSp	Outside of the specification
	MtReq	Maintenance required

Range	Description
Actuator	Diagnosis notices affecting the valve or the pneumatic actuator
Operation	Diagnosis notices with a negative effect on the operation of the positioner
Process	Diagnosis notices that refer to the process and display impairments or states
Sensor	Alarms indicating problems affecting the reading of the valve position
Electronic	Errors in the device electronics are displayed
Configuration	Detects if the positioner configuration is missing or faulty

5.1.15 Overview of parameters on the configuration level

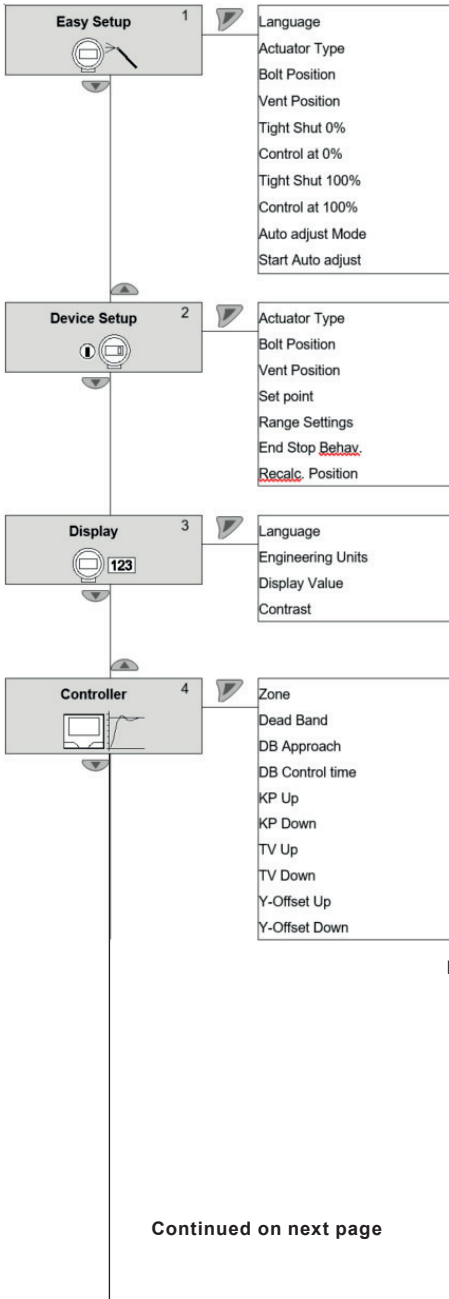

Fig.27

Continued on next page

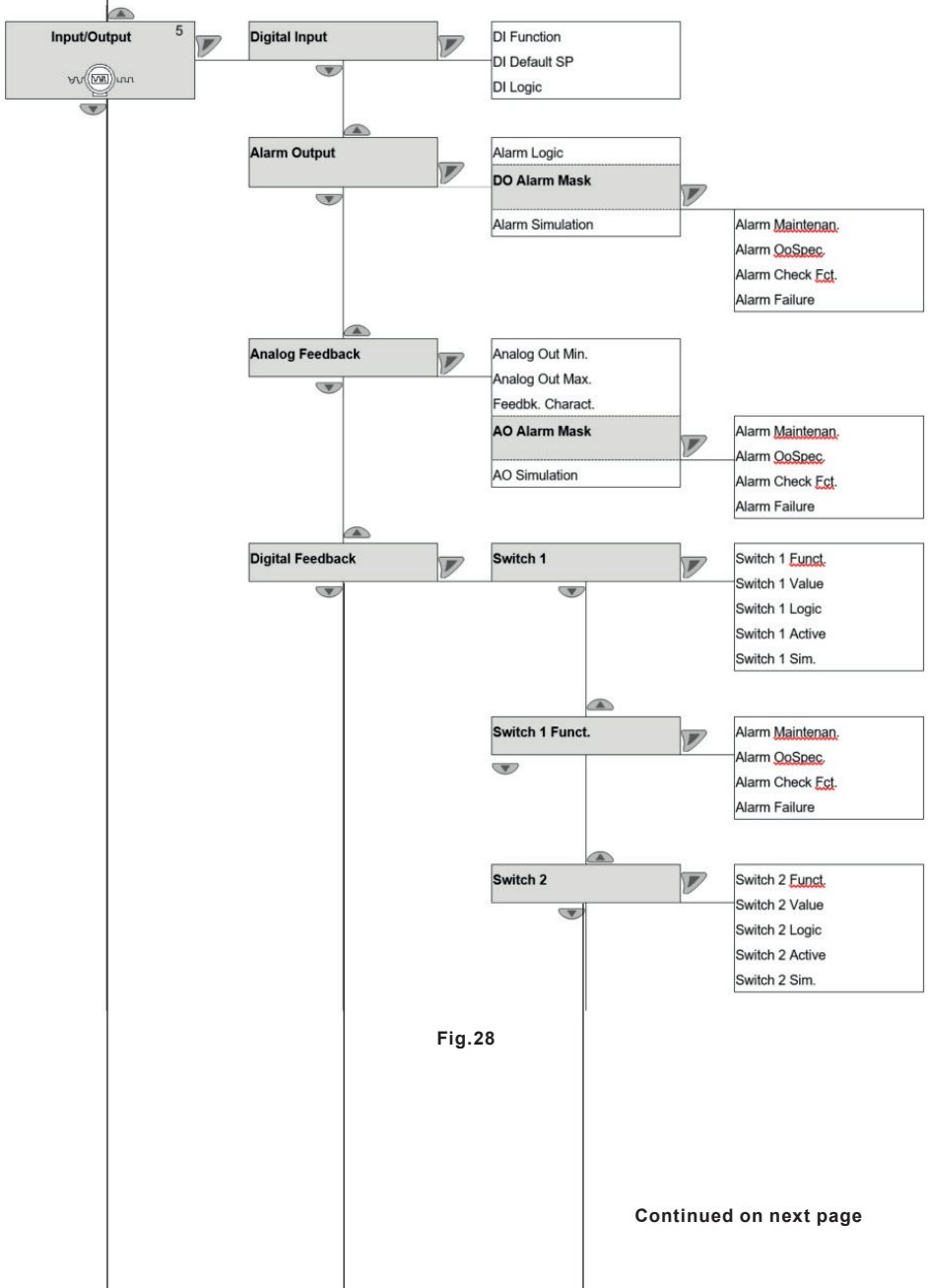

Fig.28

Continued on next page

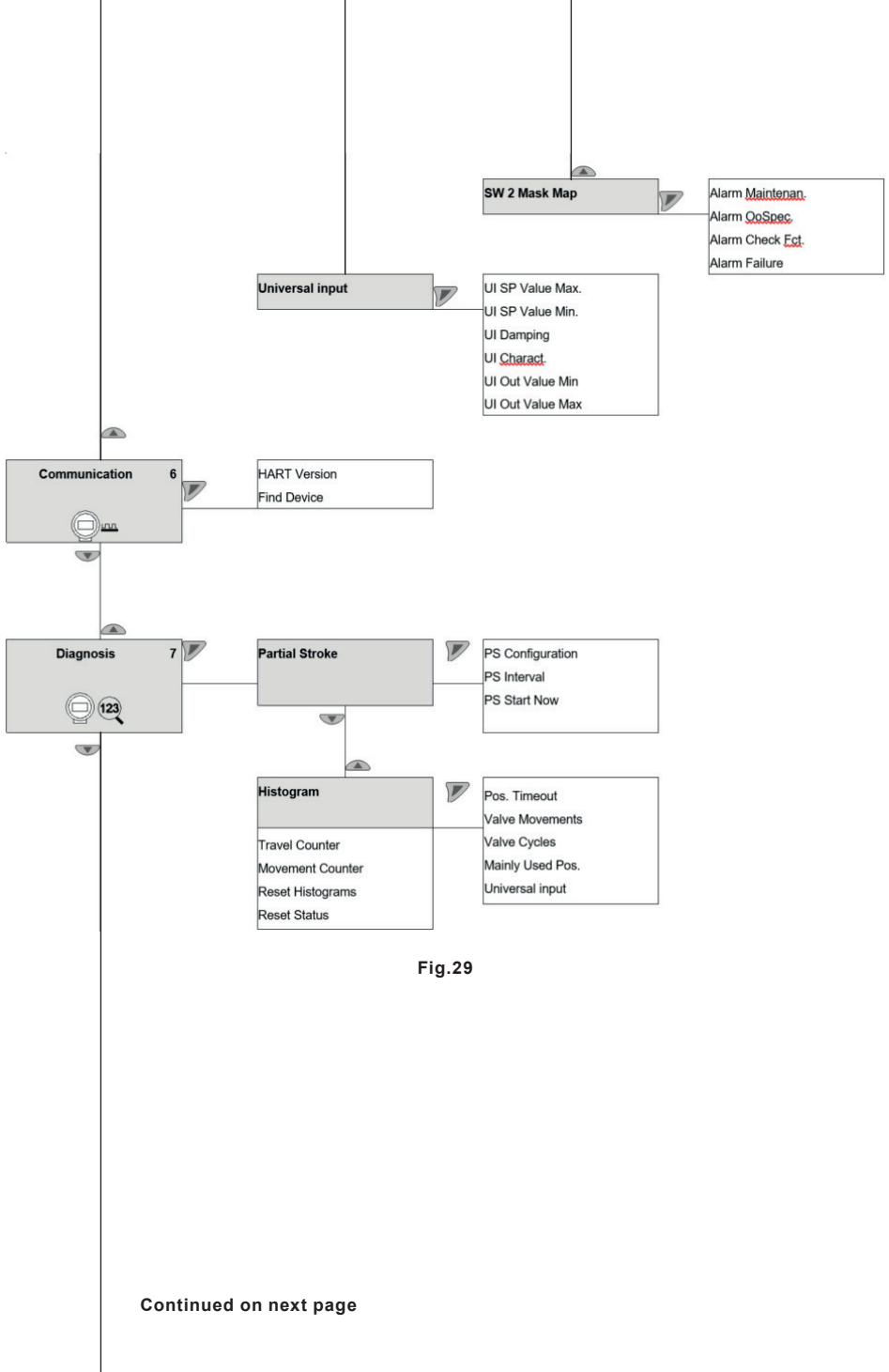

Fig.29

Continued on next page

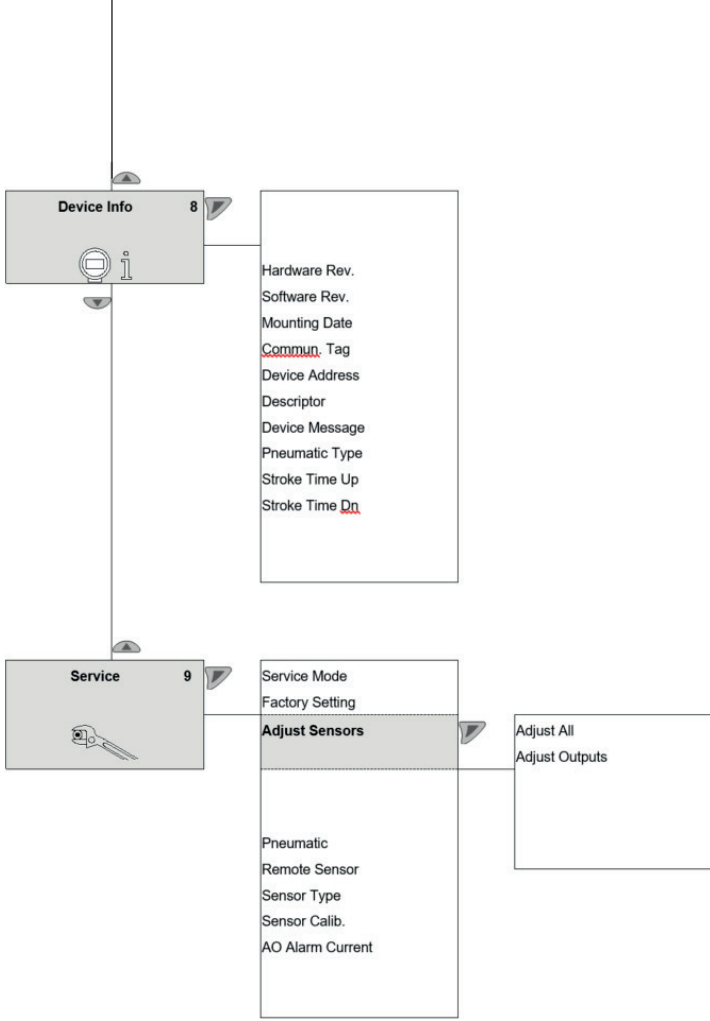

Fig.30

5.1.16 Menu easy setup

Menu/parameter	Value range	Description
Language	English, Deutsch, Français, Italiano, Español, Português	Selects the menu language
Actuator Type	Linear, Rotary	Use this parameter to configure the positioner for operation on a linear actuator (sensor range $\pm 30^\circ$) or on a rotary actuator (sensor range $\pm 45^\circ$). No mechanical modifications to the positioner are required.
Bolt Position	Bolt On Lever, Bolt On Stem	For the linearization, when attaching to linear actuators, a differentiation is made concerning the mechanical part of the position transfer to which the bolt is permanently mounted. <ul style="list-style-type: none"> - Bolt On Lever (actuator bolt on the potentiometer lever) - Bolt On Stem (actuator bolt on the valve stem) Factory setting: Bolt On Lever
Vent Position	Position 0%, Position 100%	Use this parameter to specify which position is to be shown in the display when output 1 of the positioner is completely vented.
Tight Shut 0%	0.0 to 45.0	The shut-off value is a percentage of the working range from which the 0 % position is approached. Once the specified position limit value is reached, the actuator moves into the 0% end position.
Control at 0%	On, Off	Use this parameter to set the end position behavior. If the parameter is activated, the 0 % position is controlled. Otherwise, the actuator moves into the 0 % mechanical end position.
Tight Shut 100%	55.0 to 100.0	The shut-off value is a percentage of the working range from which the 100 % position is approached. Once the specified position limit value is reached, the actuator moves into the 100 % end position.
Control at 100%	On, Off	Use this parameter to set the end position behavior. If the parameter is activated, the 100 % position is controlled. Otherwise, the actuator moves into the 100 % mechanical end position.

5.1.16 Menu easy setup (continued)

Menu/parameter	Value range	Description
DB Approach	Fast, Medium, Slow	This parameter specifies the speed at which the dead band is approached. In rare cases, overshooting can occur when the valve position is being compensated. This can be prevented by reducing the speed of the dead-band approach (DB approach).
Dead Band Calc.	Active, inactive	Use this function to activate/deactivate the control behavior on the dead band.
Autoadjust Mode	Full, Controller, Valve Range, Zero, Locked	<p>Use this parameter to define the mode or scope of the Auto Adjust function.</p> <ul style="list-style-type: none"> - Full: Complete automatic adjustment - Controller: Determine control parameters only - Zero: Determine the 0 % position only - Valve Range: Determine stops only - Locked: Automatic adjustment blocked <p>Note: On valves where slip-stick effect is significant, valve vibration can be reduced by increasing the value of the 'Zone' parameter.</p>
Start Autoadjust	Start	<p>The following values are determined during Auto Adjust:</p> <ul style="list-style-type: none"> - Direction of action of the actuator - Direction of action of the reset spring - Actuator travel of the actuator/final control element - Stroke time for both directions - Control parameters - Offset for the I/P module - Static friction of the actuator/final control element - Dynamic friction of the actuator/final control element

5.1.17 Menu Device Setup

Menu/parameter	Value range	Description
Actuator Type	Linear, Rotary	<p>Use this parameter to configure the configuration-, parameterization instruction for the positioner for operation on a linear actuator (sensor range $\pm 30^\circ$) or on a rotary actuator (sensor range $\pm 45^\circ$). No mechanical modifications to the positioner are required.</p> <p>Linearization can be selected under the 'Linear' parameter in accordance with the mounting conditions:</p>
Bolt Position	Bolt On Lever, Bolt On Stem	<p>For the linearization, when attaching to linear actuators, a differentiation is made concerning the mechanical part of the position transfer to which the actuator bolt is permanently mounted.</p> <ul style="list-style-type: none"> - Bolt On Lever (actuator bolt on the potentiometer lever) - Bolt On Stem (actuator bolt on the valve stem) <p>Factory setting: Bolt On Lever</p>
Vent Position	Position 0%, Position 100%	Use this parameter to specify which position is to be shown in the display when output 1 of the positioner is completely vented.
Set point	SP Range Min. SP Range Max. SP Filter SP Ramp Up SP Ramp Down SP Charact. Curve SP Direction	The parameters for the set point are set in this parameter group.
Range Settings	Valve Rng Calib. Upper Valve Rng Lower Valve Rng	<p>The valve end positions and the working range in which the valve is to be controlled are set in this parameter group.</p> <p>Note: If the work area is limited, the switching points of the digital feedback opposite the valve area which had possibly been previously adjusted will shift.</p>
End Stop Behav.	Tight Shut 0% Control at 0% Dead Angle 0% Tight Shut 100% Control at 100% Dead Angle 100%	The end position behavior is set in this parameter group.
Recalc. Position	Off, On	Use this parameter to define whether the position indicator and Analogue position feedback display the valve position (Direct) or the valve flow (Recalculated).

5.1.18 Set point

Menu/parameter	Value range	Description
SP Range Min.	4.0 to 18.4 mA	<p>The set point range is the range of the input current as a percentage of the operating range of the fittings from 0 to 100 %.</p> <p>Use parameter '0' to specify the lower limit for the set point range.</p>
SP Range Max.	5.6 to 20.0 mA	<p>The set point range is the range of the input current as a percentage of the operating range of the fittings from 0 to 100 %.</p> <p>Use parameter '100' to specify the upper limit for the set point range.</p> <p>Note: The configured set point range must not be smaller than 20 % (3.2 mA).</p>
SP Filter	0 to 120 seconds	Use this parameter to set a damping value for the set point signal.
SP Ramp Up	Off up to 0 to 200 seconds	<p>Here the stroke time for the actuator can be increased.</p> <p>A set point change is not directly transferred to the positioner; instead, the speed is reduced accordingly.</p>
SP Ramp Down	Off up to 0 to 200 seconds	<p>Here the stroke time for the actuator can be increased.</p> <p>A set point change is not directly transferred to the positioner; instead, the speed is reduced accordingly.</p>
SP Charact. Curve	Linear 1:25 AM 1:50 AM 25:1 50:1 Custom	<p>Use this parameter to select a function that adjusts the behavior of the positioner to the Analogue input signal in accordance with a predefined course. This linearizes the characteristic curves for the valves and fittings and improves the behavior of the overall control loop.</p> <p>In addition to five predefined characteristic curves, you can also select a user-configurable characteristic curve, which can only be generated and saved in the device via a PC with the appropriate configuration program (and not locally).</p>
SP Direction	Direct Reverse	<p>The action describes the relationship between the Analogue set point and pneumatic output 1.</p> <ul style="list-style-type: none"> - Direct: Rising, set point 0 to 100 % -> output 0 to 100 % - Reverse: Falling, set point 0 to 100 % -> output 100 to 0 %

5.1.19 Range settings

Menu/parameter	Value range	Description
Upper Valve Rng	0.0 to 100.0 %	<p>Normally, the valve range is determined automatically during Auto Adjust.</p> <p>A partial run of Auto Adjust that is limited to the control parameters or valves and fittings without end stops, however, requires manual adjustment of the valve range.</p> <p>Note: If after automatic adjustment, the valve range is manually rotated (old min. = new max. => old max. = new min.) the device no longer reacts to set point changes. A constant process value of 128 flashes on the display.</p>
Lower Valve Rng	0.0 to 100.0 %	<p>Normally, the valve range is determined automatically during Auto Adjust.</p> <p>A partial run of Auto Adjust that is limited to the control parameters or valves and fittings without end stops, however, requires manual adjustment of the valve range.</p> <p>Note: If after automatic adjustment, the valve range is manually rotated (old min. = new max. => old max. = new min.) the device no longer reacts to set point changes. A constant process value of 128 flashes on the display.</p>
Upper Working Rng	0.0 to 100.0 %	<p>The working range can be configured to be smaller than the maximum mechanical working range.</p> <p>The set point range always refers to the configured working range. Use this parameter to specify the lower limit of the working range.</p>
Lower Working Rng	0.0 to 100.0 %	<p>The working range can be configured to be smaller than the maximum mechanical working range.</p> <p>The set point range always refers to the configured working range. Use this parameter to specify the upper limit of the working range.</p>

5.1.20 End stop behav.

Menu/parameter	Value range	Description
Tight Shut 0%	0 to 45.0	<p>The shut-off value is a percentage of the working range from which the 0 % position is approached.</p> <p>Once the specified position limit value is reached, the actuator moves into the 0% end position.</p>
Control at 0%	On, Off	<p>Use this parameter to set the end position behavior. If the parameter is activated, the 0 % position is controlled. Otherwise, the actuator moves into the 0 % mechanical end position.</p>
Dead Angle 0%	0.0 to 45.0 %	<p>Use this parameter to cut off the unusable range of the valve flow characteristic curve from the point of view of control. The dead angle is a percentage of the working range to which the valve is moved if the input signal is 4.16 mA.</p> <p>Note: If the parameter is changed, the switching points of the binary feedback opposite the valve area which had possibly been previously adjusted will shift.</p>
Tight Shut 100%	55.0 to 100	<p>The shut-off value is a percentage of the working range from which the 100 % position is approached.</p> <p>Once the specified position limit value is reached, the actuator moves into the 100 % end position.</p>
Control at 100%	On, Off	<p>Use this parameter to set the end position behavior. If the parameter is activated, the 100% position is controlled. Otherwise, the actuator moves into the 100% mechanical end position.</p>
Dead Angle 100%	55.0 to 100.0 %	<p>Use this parameter to cut off the unusable range of the valve flow characteristic curve from the point of view of control. The dead angle is a percentage of the working range to which the valve is moved if the input signal is 19.84 mA.</p> <p>Note: If the parameter is changed, the switching points of the binary feedback opposite the valve area which had possibly been previously adjusted will shift.</p>

5.1.21 Menu: Display

Menu/parameter	Value range	Description
Language	English, Deutsch, Français, Italiano, Español, Português	Selects the menu language
Engineering Units	Temperature Pressure Universal input	<p>Use this parameter to select the units to be displayed.</p> <ul style="list-style-type: none"> - Temperature: - °C degrees Celsius - °F degrees Fahrenheit - °R degrees Rankine - K Kelvin - Pressure: - psi - bar - kPa - Mpa - Universal input: <p>The unit can only be entered in plain text using a DTM/EDD.</p>
Display Value	Position % Position ° Set point % Set point mA Deviation % Temperature Univ. Inp. Press. Y1 Press. Y2 Diff. Press. Supply Press.	<p>Use this parameter to select which value is to be shown on the process display.</p> <ul style="list-style-type: none"> - Position % - Position in % - Position ° - Position in degrees - Set point % - Set point in % - Set point mA - Set point in mA - Deviation % - Control deviation in % - Temperature - Device temperature - Univ. IN - Scaled value at universal input - Press. Y1 - Pressure output 1 - Press. Y2 - Pressure output 2 - Diff. Press. - Differential pressure between the outputs - Supply Press. - Supply air pressure
Contrast	0 to 100 %	Display contrast

5.1.22 Menu: Controller

Menu/parameter	Value range	Description
Zone	1 to 100 in steps of 1	<p>This parameter specifies the point at which the control structure is switched over when the dead band is being approached.</p> <p>Note: On valves where slip-stick effect is significant, valve vibration can be reduced by increasing the value of the 'Zone' parameter.</p>
Dead Band	0.10 to 10.00 % in steps of 0.01 %	<p>The dead band defines a +/- range around the position set point. Once the valves and fittings reach this range, the positioner maintains this position.</p>
Dead Band Calc.	Active, inactive	<p>Use this function to activate/deactivate the control behavior on the dead band.</p>
DB Approach	Fast Medium Slow	<p>This parameter specifies the speed at which the dead band is approached. In rare cases, overshooting can occur when the valve position is being compensated. This can be prevented by reducing the speed of the dead band approach (DB Approach).</p>
DB Control time	0 to 30 s	<p>In some cases it can happen that the valve continues moving slowly after reaching the dead band and leaves the dead band again. To prevent this, this parameter can be used to specify how long the controller should be active after reaching the dead band.</p> <p>Factory setting: 0 s</p>
DB Close-Up Range	0 to 1000 s.	<p>Use this parameter to enter a monitoring time up to the point at which the dead band is reached. When the dead band is exceeded, the monitoring time is started. If the dead band around the new position set point is not reached again within the specified time, an alarm is triggered.</p> <p>Once the set point has been reached, the alarm is automatically reset.</p> <p>Note:</p> <ul style="list-style-type: none"> - With active shutoff there is no alarm message. Once the set point has been reached, the alarm is automatically reset. - The monitoring stroke time is determined during automatic adjustment. Selecting a value of '0 s' deactivates this parameter.

5.1.23 Menu: Controller (continued)

Menu/parameter	Value range	Description
KP Up	1.0 to 400.0	Use this parameter to adjust the KP value for the up positioning direction (towards 100 %).
		The KP value is the gain of the controller. The control speed and stability are influenced by the KP value. With higher KP values, the control speed increases.
		To compensate for existing dissymmetries in the controlled system, the KP value should be set separately for both positioning directions (up/down).
		For most actuators, satisfactory control behavior is achieved with a KP value between 2.0 and 10.0.
		Note: The control precision is not affected by the KP value.
KP Down	1.0 to 400.0	Use this parameter to adjust the KP value for the down positioning direction (towards 0 %).
		The KP value is the gain of the controller. The control speed and stability are influenced by the KP value. With higher KP values, the control speed increases.
		To compensate for existing dissymmetries in the controlled system, the KP value should be set separately for both positioning directions (up/down).
		For most actuators, satisfactory control behavior is achieved with a KP value between 2.0 and 10.0.
		Note: The control precision is not affected by the KP value.
TV Up	10 to 800 ms	Use this parameter to adjust the KP value for the up positioning direction (towards 100 %).
		The TV value is the derivative time of the controller. The control speed and stability are affected by the TV value in such a way that it counteracts the KP value dynamically. The control speed decreases as the TV value increases.
		To compensate for existing dissymmetries in the controlled system, the TV value should be configured separately for both positioning directions (up/down).

5.1.23 Menu: Controller (continued)

Menu/parameter	Value range	Description
TV Down	10 to 800 ms	<p>Use this parameter to adjust the TV value for the down positioning direction (towards 0 %).</p> <p>The TV value is the derivative time of the controller.</p> <p>The control speed and stability are affected by the TV value in such a way that it counteracts the KP value dynamically. The control speed decreases as the TV value increases.</p> <p>To compensate for existing dissymmetries in the controlled system, the TV value should be configured separately for both positioning directions (up/down).</p>
Y-Offset Up	1 to 100.0 %	<p>Use this parameter to adjust the Y offset for the up positioning direction (towards 100 %).</p> <p>The 'offset for the set point signal' linearizes the behavior of the I/P module used and enables rapid compensation even in the case of small control deviations.</p> <p>The value is limited at the lower end by a minimum value (measuring range lower limit). The offset significantly affects the control speed for control deviations of less than 5 %.</p> <p>To compensate for existing dissymmetries in the controlled system, the offset should be configured separately for both positioning directions (up/down).</p> <p>For most actuators, satisfactory control behavior is achieved with offset values between 40 and 80 %.</p> <p>If, in the event of set point changes, the control behavior demonstrates an overshoot of less than 2 %, both offset values should be decreased.</p> <p>Both offset values should be increased when the actuator stops outside the dead band.</p>

5.1.23 Menu: Controller (continued)

Menu/parameter	Value range	Description
Y-Offset Down	1 to 100.0 %	<p>Use this parameter to adjust the Y offset for the down positioning direction (towards 0 %).</p> <p>The 'offset for the set point signal' linearizes the behavior of the I/P module used and enables rapid compensation even in the case of small control deviations. The value is limited at the lower end by a minimum value (neutral zone).</p> <p>The offset significantly affects the control speed for control deviations of less than 5 %.</p> <p>To compensate for existing dissymmetries in the controlled system, the offset should be configured separately for both positioning directions (up/down).</p> <p>For most actuators, satisfactory control behavior is achieved with offset values between 40 ... 80 %.</p> <p>If, in the event of set point changes, the control behavior demonstrates an overshoot of less than 2%, both offset values should be decreased.</p> <p>Both offset values should be increased when the actuator stops outside the dead band.</p>

Note:

In the case of most actuators, all control parameters can be optimized by using Auto Adjust. The parameters should only be changed if Auto Adjust cannot be executed or does not result in satisfactory control behavior.

5.1.24 Menu: Input/Output

Menu/parameter	Value range	Description
Digital Input	DI Function DI Default SP DI Logic	Selection of functions or states that are executed or adopted if the 'digital input' has been activated.
Alarm Output	Alarm Logic DO Alarm Mask Alarm Simulation	Use this parameter to configure the alarm output via which a general alarm can be issued. Depending on the activated Namur classification group, it is also possible for the general alarm to be issued as an alarm current.
Analogue Feedback	Analogue Out Min. Analogue Out Max. Feedbk. Charact. AO Alarm Mask AO Simulation	The current valve position (or when the 'backward-calculated characteristics of the valve influence') is reported back as a current signal via the Analogue feedback message. Depending on the activated Namur classification group, it is also possible for the general alarm to be issued as an alarm current.
Digital Feedback	Switch 1 SW 1 Mask Map Switch 2 SW 2 Mask Map	Binary feedback can be used to configure two limit switches which are able to report when a value is reached or exceeded, via a current signal. Additionally, diagnostics bits can be output via the second switch.
Universal input	UI SP Value Max. UI SP Value Min. UI Damping UI Charact. UI Out Value Max UI Out Value Min	Use this menu item to configure and simulate the universal input.

5.1.25 Menu Digital input

Menu/parameter	Value range	Description
DI Function	Off Hold Last SP Hold User SP Hold Last Pos. Vent. Out1 Vent. Out2 Freeze Outputs Partial Stroke Test Service Required Safety Position Conf. Locked Panel Locked Locked	- Off - No function
		- Hold Last SP - Last set point is retained
		- Hold User SP - Substitute value for set point (defined in 'DI Default Setup.')
		- Hold Last Pos. - Hold previous position
		- Vent. Out1 - Vent Output 1
		- Vent. Out2 - Vent Output 2
		- Freeze Outputs - Close pneumatic outputs
		- Partial Stroke Test - Start Partial Stroke Test
		- Service Required - Issue diagnosis bit via binary feedback
		- Safety Position - Approach safety position
		- Conf. Locked - Block local configuration
		- Panel Locked - Block local operation
		- Locked - Block all operation and setting options
DI Default SP	0 to 100%	The position defined using this parameter is approached when the 'Digital Input' function has been set to 'Hold User SP' and the digital input has been activated.
DI Logic	Active High, Active Low	Use this parameter to configure the contact logic for activating the digital input.
		Note: For the following parameters, the contact logic is always 'Active Low' or 'Off':
		- Safety Position
		- Conf. Locked
		- Panel Locked
- Locked		

5.1.26 Menu: Alarm output

Menu/parameter	Value range	Description
Alarm Logic	Active High, Active Low	<p>Use this parameter to define the contact logic for the alarm output.</p> <ul style="list-style-type: none"> - Active High - $I > 2.1 \text{ mA}$ - Active Low - $I < 1.2 \text{ mA}$
DO Alarm Mask	Alarm Maintenanc., Alarm OoSpec., Alarm Check Fct., Alarm Failure	<p>Use this parameter to select which general alarms are output as an alarm current, depending on the activated Namur classification group.</p> <ul style="list-style-type: none"> - Alarm Maintenanc. - Maintenance needed - Alarm OoSpec. - Operation outside specifications - Alarm Check Fct. - Functional test needed - Alarm Failure - Errors
Alarm Simulation	Off, Low, High	The presence of an alarm can be simulated here in order to output the alarm current.

5.1.27 Menu: Analogue feedback

Menu/parameter	Value range	Description
Analogue Out Min.	4.0 to 18.4 mA	<p>Use this parameter to specify the lower current range limit for the Analogue feedback. The current range corresponds to the configured stroke range.</p> <p>Note: The current range limits can be freely configured between 4 and 18.5 mA. However, the current range must not be smaller than 10 % (1.6 mA).</p>
Analogue Out Max.	5.6 to 20.0 mA	<p>Use this parameter to specify the upper current range limit for the Analogue feedback. The current range corresponds to the configured stroke range.</p> <p>Note: The current range limits can be freely configured between 4 and 20 mA. However, the current range must not be smaller than 10 % (1.6 mA).</p>
Feedbk. Charact.	Direct, Reverse	<p>Use this parameter to specify the characteristic curve for the Analogue feedback.</p> <ul style="list-style-type: none"> - Direct (rising) = Position 0 to 100 % = Signal 4 to 20 mA - Reverse (falling) = Position 0 to 100 % = Signal 20 to 4 mA
AO Alarm Mask	Alarm Maintenanc. Alarm OoSpec. Alarm Check Fct. Alarm Failure	<p>When a general alarm is issued, an alarm current can be sent via the Analogue position feedback. These alarm groups are defined in accordance with Namur NE107.</p> <p>A high alarm current ('High' $I > 21$ mA), low alarm current ('Low' $I < 3.6$ mA, or 'Off') can be set for each individual group.</p>
AO Simulation	Off Low High Input current HW Alarm Current	<p>The Analogue position feedback function is simulated in this parameter group.</p> <ul style="list-style-type: none"> - Off - Terminate simulation. - Reverse - Alarm current $I < 3.6$ mA - High - Alarm current $I > 21$ mA - Input current - The input current of the positioner is output. - HW Alarm Current - The 'AO Alarm Current' set in 'Service Mode' is output.

5.1.28 Menu: Digital feedback

Menu/parameter	Value range	Description
Switch 1	Switch 1 Funct. Switch 1 Value Switch 1 Logic Switch 1 Active	The function of switch 1 is configured in this parameter group.
		- Switch 1 Funct. - Switch 1 function
		- Switch 1 Value - Switch 1 value
		- Switch 1 Logic - Switch 1 logic
SW 1 Mask Map	Alarm Maintenan. Alarm OoSpec. Alarm Check Fct. Alarm Failure Switch 1 Sim.	The function of switch 1 MASK MAP' is configured in this parameter group.
		- SW 1 Mask Map - Switch 1 diagnosis classification
		- Switch 1 Sim - Switch 1 simulation
Switch 2	Switch 1 Funct. Switch 1 Value Switch 1 Logic Switch 1 Active	The function of switch 2 is configured in this parameter group.
		- Switch 2 Funct. - Switch 2 function
		- Switch 2 Value - Switch 2 value
		- Switch 2 Logic - Switch 2 logic
		- Switch 2 Active - Switch 2 activation
		- SW 2 Mask Map - Switch 2 diagnosis classification
SW 2 Mask Map	Alarm Maintenan. Alarm OoSpec. Alarm Check Fct. Alarm Failure Switch 2 Sim.	The function of switch '2 MASK MAP' is configured in this parameter group.
		- SW 2 Mask Map - Switch 2 diagnosis classification
		- Switch 2 Sim. - Switch 2 simulation

5.1.29 Menu: Switch 1

Menu/parameter	Value range	Description
Switch 1 Funct.	Position Info Diagnostic State	<p>Use this parameter to select whether the switch is to be used as a limit signal generator or for signaling diagnostics messages.</p> <ul style="list-style-type: none"> - Position Info - Evaluate position - Diagnostic State - Assess diagnosis status
Switch 1 Value	0 to 100%	<p>Use this parameter to configure the position value as a limit signal generator. It is taken into account when the 'Switch 1 Funct.' parameter is set to 'Position Info'.</p>
Switch 1 Logic	Active High Active Low	<p>Use this parameter to select the contact logic.</p> <ul style="list-style-type: none"> - Active High (active) - Output current I > 2.1 mA - Active Low (active) - Active Low (active) = Output current I < 1.2 mA
Switch 1 Active	Fall below, Exceeding	<p>Use this parameter to select the edge for activating the switch.</p> <ul style="list-style-type: none"> - Off - Deactivated - Fall below - If down-scaled - Exceeding - If up-scaled

5.1.30 Menu SW 1 Mask map

Menu/parameter	Value range	Description
Alarm Maintenan. Alarm OoSpec. Alarm Check Fct. Alarm Failure	On, Off	<p>When a general alarm is issued, an alarm current can be sent via the Analogue position feedback. These alarm groups are defined in accordance with Namur NE107. Each individual group can be activated.</p> <ul style="list-style-type: none"> - Alarm Maintenan. - Maintenance needed - Alarm OoSpec. - Operation outside specifications - Alarm Check Fct. - Functional test needed - Alarm Failure - Errors
Switch 1 Sim.	On, Off	<p>Use this parameter to simulate the switch function.</p> <ul style="list-style-type: none"> - Off - Simulation deactivated

5.1.31 Menu: SW 2 Mask map

Menu/parameter	Value range	Description
Alarm Maintenanc. Alarm OoSpec. Alarm Check Fct. Alarm Failure	On, Off	<p>When a general alarm is issued, an alarm current can be sent via the Analogue position feedback. These alarm groups are defined in accordance with Namur NE107. Each individual group can be activated.</p> <ul style="list-style-type: none"> - Alarm Maintenanc. - Maintenance needed - Alarm OoSpec. - Operation outside specifications - Alarm Check Fct. - Functional test needed - Alarm Failure - Errors
Switch 1 Sim.	On, Off	<p>Use this parameter to simulate the switch function.</p> <ul style="list-style-type: none"> - Off - Simulation deactivated

5.1.32 Menu: Switch 2

Menu/parameter	Value range	Description
Switch 2 Funct.	Position Info Diagnostic State	<p>Use this parameter to select whether the switch is to be used as a limit signal generator or for signaling diagnostics messages.</p> <ul style="list-style-type: none"> - Position Info - Evaluate position - Diagnostic State - Assess diagnosis status
Switch 2 Value	0 to 100%	<p>Use this parameter to configure the position value as a limit signal generator. It is taken into account when the 'Switch 2 Funct.' parameter is set to 'Position Info'.</p>
Switch 1 Logic	Active High Active Low	<p>Use this parameter to select the contact logic.</p> <ul style="list-style-type: none"> - Active High (active) - Output current $I > 2.1$ mA - Active Low (active) - Output current $I < 1.2$ mA
Switch 1 Active	Fall below, Exceeding	<p>Use this parameter to select the edge for activating the switch.</p> <ul style="list-style-type: none"> - Off - Deactivated - Fall below - If down-scaled - Exceeding - If up-scaled

5.1.33 Menu: Universal input

Menu/parameter	Value range	Description
UI SP Value Max.	4.0 to 20.0 mA	Use this parameter to specify the upper current range limit for the universal input.
UI SP Value Min.	4.0 to 20.0 mA	Use this parameter to specify the lower current range limit for the universal input.
UI Damping	0 to 60 s	Use this parameter to set a damping value for the universal input signal.
UI Charact.	Linear, Custom	<p>Use this parameter to select a function that adjusts the behavior of the positioner to the Analogue input signal according to a predefined course.</p> <p>This linearizes the characteristic curves for the valves and fittings and improves the behavior of the overall control loop.</p> <ul style="list-style-type: none"> - Linear - linear - Custom - configurable by user <p>The user-configurable characteristic curve cannot be generated and saved in the device locally, however; this can only be done via a PC with the appropriate configuration program (DTM/EDD).</p>
UI Out Value Min	0.0 to 30000	Use this parameter to define which value is assigned to the minimum universal input signal 'UI SP Value Min.'.
UI Out Value Max	0.0 to 30000	Use this parameter to define which value is assigned to the maximum universal input signal 'UI SP Value Max.'.

5.1.34 Menu: Communication

Menu/parameter	Value range	Description
		<p>Use this parameter to define the HART protocol via which the device is to communicate. (setting)</p> <ul style="list-style-type: none"> - HART 5 - HART Protocol 5.9 - HART 7 - HART Protocol 7.2 (factory setting)
HART Version	HART 5, HART 7	<p>Note:</p> <ul style="list-style-type: none"> - If the HART 7 function 'Write protection (Lock ALL)' has been activated via the DTM/EDD and communication has been switched to HART 5 on the device, write protection is canceled when the device is restarted. - In the event of a switch from HART 7 to HART 5, if write protection has been activated via HART 7, it is deactivated when the device is restarted. - When switching from HART 5 to HART 7, device addresses greater than number 15 are set to 0.
Find Device*	Off* Find Once* Find Continuous*	<p>If 'Find Once' is selected, after HART command #73 is received the device responds once with HART command #73, which has the same content as command #0.</p> <p>If 'Find Continuous' is selected - after HART Command #73 is received, the device responds recurrently with HART Command #73, which has the same content as Command #0. Selecting the 'Off' parameter ends the 'Find Device' function.</p>

* Parameter only visible if HART 7 has been selected.

5.1.35 Menu: Diagnosis

Menu/parameter	Value range	Description
Partial Stroke	PS Configuration, PS Interval, PS Start Now	<p>'Partial Stroke Test' is used to test the mobility of the safety-related valves and fittings. For this purpose, the valve is moved by a configurable amount in the direction of the safety position (venting of positioner output 1).</p> <p>If this does not happen within the expected time, an alarm is signaled. After the test, the valve follows the current set point again.</p> <p>The start of the test is triggered using a time interval 'PS Interval', through the digital input (configuration: Input/Output-> Digital Input-> DI Function -> Partial Stroke) or locally on the device 'PS Start Now'.</p>
Histogram	Pos. Timeout Valve Movements Valve Cycles Mainly Used Pos. Universal input	<p>Use this parameter to select which histogram is to be displayed.</p> <p>In this menu, the number of values or events is assigned to a valve range and displayed as an individual bar graph. The valve ranges are divided up as follows:</p> <p>< 0 %, 0 - 10 %, 10 - 20 %, 20 - 30 %, 30 - 40 %, 40 - 50 %, 50 - 60%, 60 - 70 %, 70 - 80 %, 80 - 90%, 90 - 100 %, > 100 %</p> <p>The histograms support valve diagnostics and allow conclusions to be drawn about the valve, control quality, wear, and properties of the valves and fittings.</p> <ul style="list-style-type: none"> - Pos. Timeout - Number of 'positioning time too slow' events - Valve Movements - Number of valve movements - Valve Cycles - Number of valve lifts - Mainly Used Pos. - Most used valve position - Universal input - Universal input value
Travel Counter	0 to 200,000,000	<p>The 'Travel Counter' is used to determine the positioner travel. The counter adds up the distance traveled as a % of the set 'operating range'.</p> <p>Limit values can be configured for the counter (only via DTM/EDD). If the 'Travel Counter' reaches a limit value, a message is output.</p>

5.1.36 Menu: Diagnosis (continued)

Menu/parameter	Value range	Description
Movement Counter	0 to 200,000,000	<p>The 'Movement Counter' is used to determine the actuator's movements. Any movement that exceeds the defined hysteresis is counted (default setting: 50%).</p> <p>The hysteresis can only be set/changed using a PC (DTM/EDD). Limit values can be configured for the movement counter (only via DTM/EDD). If the counter reaches a limit value, a message is output.</p>
Reset Histograms		<ul style="list-style-type: none"> - Use this parameter to reset the histograms.
Reset Status		<ul style="list-style-type: none"> - Use this parameter to reset the diagnostic status.

5.1.37 Menu: Partial stroke

Menu/parameter	Value range	Description
PS Configuration	PS Vent Amount, Timeout Value Dead Time	<ul style="list-style-type: none"> - PS Vent Amount: Position change in the direction of the safety position (venting of positioner output 1) by which the valve is to be moved. - Timeout Value: If the valve does not reach the new valve position, which has changed by the amount defined by 'PS Vent Amount', within the defined time (Timeout Time), an alarm is issued. <p>The step response from the DTM can be used to determine the partial stroke parameters</p> <p>Note: The default setting for this time is automatically determined by Auto Adjust (only in Auto Adjust mode: Valve Ranges, Full).</p> <ul style="list-style-type: none"> - Dead Time: Use this parameter (dead time) to set the time in which the valve should have moved out of the end position. The dead time must be less than half the 'Timeout Value'. <p>Note: The partial stroke must be tested after configuration!</p>
PS Interval	0 to 1000 days	Use this parameter to define the time interval according to which the 'Partial Stroke Test' is triggered on a cyclical basis.
PS Start Now	Test Passed Test Failed	<p>Use this parameter to trigger the partial stroke directly. The result is shown on the display:</p> <ul style="list-style-type: none"> - Test Passed - Test successful - Test Failed - Test failed

5.1.38 Menu: Device info

Note:

This menu is only used to display the device parameters. The parameters are displayed independently of the configured access level, but cannot be changed.

Menu/parameter	Value range	Description
Hardware Rev.		The hardware revision is displayed here.
Software Rev.		The firmware revision is displayed here.
Mounting Date		The installation date is displayed here. The date can only be entered and changed using a PC (DTM/EDD).
Commun. Tag		The communication name is displayed here. The name can only be entered and changed using a PC (DTM/EDD).
Long Tag*		The long text for the measuring point tag is displayed here.
Device Address		The device address is displayed here.
Descriptor		The measuring point tagging is displayed here. The description can only be entered and changed using a PC (DTM/EDD).
Device Message		The device information is displayed here. The description can only be entered and changed using a PC (DTM/EDD).
Pneumatic Type	Single/Safe Single/Freeze Double/Safe Double/Freeze	<p>The type of pneumatics that the device works with is displayed here. After installing a different type of pneumatics, this type needs to be set in the 'Service -> Pneumatic' menu.</p> <ul style="list-style-type: none"> - Single/Safe - Single acting, safety position with no current, with venting function - Single/Freeze - Single acting, safety position with no current, with blocking function - Double/Safe - Double acting, safety position with no current, with venting function - Double/Freeze - Double acting, safety position with no current, with blocking function
Stroke Time Up	0 to 200 s	The stroke time determined by Auto Adjust (only Auto Adjust types 'Stroke' and 'Full') for the direction of the 100 % position is displayed here
Stroke Time Dn	0 to 200 s	The stroke time determined by Auto Adjust (only Auto Adjust types 'Stroke' and 'Full') for the direction of the 0 % position is displayed here.

*Visible only with HART 7

5.1.39 Menu: Service

Menu/parameter	Value range	Description
Service Mode	Off, On*	Activate service mode.
Factory Setting*	-	Load factory settings
		<p>Note: The supply pressure and the drive must not be pressurized for calibration to atmospheric pressure. Otherwise, the existing pressure is applied as the zero point.</p>
Adjust Sensors*	Adjust All, Adjust Outputs	<p>In order to set the zero point for the pressure sensors, the pneumatic device connections for the supply air and actuator must be disconnected and vented. The sensors will then be calibrated to the atmospheric pressure.</p> <ul style="list-style-type: none"> - Supply Pressure - Supply air pressure - Pressure Y1 - Pressure, output 1 - Pressure Y2 - Pressure, output 2
		<p>Use this parameter to adapt the positioner software to the installed I/P module. This is required when installing a different I/P module type.</p>
Pneumatic*	Single/Safe Single/Freeze Double/Safe Double/Freeze	<p>The type of pneumatics that the device works with is displayed here.</p> <ul style="list-style-type: none"> - Single/Safe - Single acting, safety position with no current, with venting function - Single/Freeze - Single acting, safety position with no current, with blocking function - Double/Safe - Double acting, safety position with no current, with venting function - Double/Freeze - Double acting, safety position with no current, with blocking function
Remote Sensor*	Off, On	If an external position sensor is connected, this parameter must be set to 'On'.
Sensor Type*	Standard Non-Contact External Sensor No Linearization	<p>Use this parameter to select the version of the installed position sensor.</p> <ul style="list-style-type: none"> - Standard - Standard position sensor - Non-Contact - Contactless position sensor

5.1.40 Menu: Service (continued)

Menu/parameter	Value range	Description
Sensor Calib.*	Value 1 ... Value 5 Confirm	<p>Once the position sensor has been replaced, the correction values used for linearizing the sensor characteristic curve (supplied by the factory together with the position sensor) can be entered here.</p> <p>The entered values are accepted by using 'Confirm'.</p>
Sensor Position	0° Position	<p>Use this parameter to set the fine adjustment of the 0° position after a sensor replacement.</p> <p>The current position of the sensor range is accepted as a center position by using 'Confirm'.</p>
AO Alarm Current*	Low, High	<p>Use this parameter to set the alarm current for the Analogue position feedback. This current is output even if the positioner is in a no-current state (external supply).</p> <ul style="list-style-type: none">- High - I > 21.5 mA- Low - I < 3.6 mA

*Parameter is only visible if Service Mode is set to 'On'.

6. Troubleshooting

6.1 Diagnosis/error messages

6.1.1 Calling up the error description

Additional details about the error that has occurred can be called up on the information level.



1. Use **LEFT** to switch to the information level (Operator Menu).

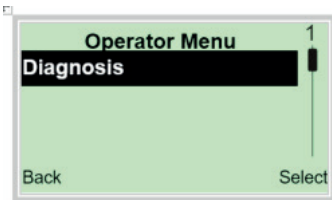

2. Use **UP/DOWN** to select the submenu 'Diagnosis'.

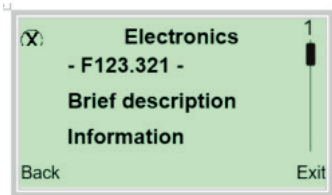

3. Confirm the selection with **RIGHT**.

The error message is shown on the display according to priority.

The first line shows the area in which the error has occurred.

The second line shows the unique error number. It is made up of the priority (Fxxx) and the error position (.xxx)





The next lines show a brief description of the error and information on how to remedy it.

You absolutely need to scroll the display further to read the error message in more detail.

Note:

For a detailed description of the error messages and information on troubleshooting, see the following pages.





6.1.2 Error messages

No.	Priority	Fault message	Possible cause	Troubleshooting the instrument					Group
1	90	Position measurement Failure	Defective position sensor	Replace position sensor	X				Sensor
2	91	Valve blocked	Friction too high	Valve requires maintenance	X				Actuator
3	50	Positioning timeout - Check valve maintenance	Positioning time up-scaled friction high	Valve requires maintenance				X	Actuator
4	51	Positioning unstable	Change disturbance variables	Select 'Adaptive Control' mode				X	Configuration
5	49	Position out of travel range	Mounting kit is bent	Check mounting conditions				X	Process
6	52	Zero-Point displacement	Valve seat is damaged	Valve requires maintenance				X	Process
7	43	kp up exceeded	Friction too high	Valve requires maintenance				X	
8	44	kp Down exceeded	Friction too high	Valve requires maintenance				X	
9	92	Set point failure electronics	Faulty electronics	Replace electronics	X				Electronics
10	70	Set point out of range	Defective DCS card	Replace DCS card			X		Special Requirements
11	80	Device not calibrated	Auto adjust has not yet been executed	Execute auto adjust				X	Configuration
12	79	Controller inactive	Test function activated	Test function deactivated				X	

6.1.2 Error messages (continued)

No.	Priority	Fault message	Possible cause	Troubleshooting the instrument	F	C	S	M	Group
13	53	Stroke counter limit exceeded	Many valve strokes	Valve requires maintenance				X	
14	54	Travel counter limit exceeded	Many valve strokes or vibrating valve	Valve requires maintenance				X	
15	55	Electronic temperature measurement failure	Temperature sensor defective	Replace electronics				X	Electronics
16	71	Electronic temperature out of limits	Temperature is too high or too low	Check mounting conditions		X			Special Requirements
17	94	Configuration data failure	Output piping mixed up	Check mounting conditions	X				Actuator
18	95	Electronics - NV chip defect	Faulty electronics	Replace electronics	X				Electronics
19	96	Non volatile data defect	Faulty electronics	Replace electronics	X				Electronics
20	56	Leakage during operation	Leakage in actuator, piping, connections, or positioner	Start leakage test				X	Actuator
21	57	Leakage chamber 1	Leakage in chamber 1 of the actuator or pneumatics output line 1	Check chamber 1 of the actuator or pneumatics output line 1				X	Actuator
22	58	Leakage chamber 2	Leakage in chamber 2 of the actuator or pneumatics output line 2	Check chamber 2 of the actuator or pneumatics output line 2				X	Actuator





6.1.2 Error messages (continued)

No.	Priority	Fault message	Possible cause	Troubleshooting the instrument					Group
23	59	Leakage in actuator	Leakage inside the actuator	Check the actuator diaphragms				X	Actuator
24	78	Pressure NV Data defect		Restart device				X	Electronics
25	83	Pressure NV chip defect		Replace pressure option				X	Electronics
26	73	Overpressure from supply	Supply air pressure too high	Check supply air pressure			X		Special Requirements
27	74	Overpressure from supply	Supply air pressure is too low or filter is clogged	Check supply air pressure or filter			X		Special Requirements
28	75	Supply pressure limit high exceeded	Supply air pressure too high	Check supply air pressure			X		Special Requirements
29	76	Pressure hammer from supply	Pressure shock in compressed air supply air pressure too high	Check air supply			X		
30	40	tv up exceeded	Excessive dynamic friction	Valve requires maintenance				X	Actuator
31	45	tv down exceeded	Excessive friction	Valve requires maintenance				X	Actuator
32	41	Y-Offset Up exceeded	Excessive dynamic friction	Valve requires maintenance				X	Actuator
33	42	Y-Offset Down exceeded	Excessive friction	Valve requires maintenance				X	Actuator

6.1.2 Error messages (continued)

No.	Priority	Fault message	Possible cause	Troubleshooting the instrument	X F	V C	A S	M	Group
34	61	Friction limit exceeded	Excessive dynamic friction	Valve requires maintenance				X	Actuator
35	62	Stiction limit exceeded	Excessive friction	Valve requires maintenance				X	Actuator
36	77	Universal input out of range	Input range area up-scaled	Check parameterization		X			
37	63	Partial stroke failed	The partial stroke test has failed	Check valve.				X	
38	64	Option module defect	Defective option module	Replace option module				X	Electronics
39	65	Universal input limit exceeded	Universal input limit value up-scaled	Depends on application				X	Actuator
40	47	Analogue output simulation active	Analogue feedback monitor simulation active	Terminate simulation.		X			
41	46	Binary output simulation active	Alarm current binary output simulation active	Terminate simulation.		X			
42	97	Fail safe active - via device error	Positioner in safety position due to device failure	Check next error message, determine and eliminate cause.	X				
43	66	Fail safe active - via user	Positioner in safety position due to user action	Switch off service mode		X			Special Requirements
44	67	Binary input active	Digital input activated by the user	Deactivate the digital input		X			Special Requirements

6.1.2 Error messages (continued)

No.	Priority	Fault message	Possible cause	Troubleshooting the instrument					Group
45	68	Switchpoint 1 exceeded	Valve has passed limit 1 position	Depends on application	X				Process
46	69	Switchpoint 2 exceeded	Valve has passed limit 2 position	Depends on application	X				Process
47	82	Analogue output supply fault	No power supply on Analogue output	Check the supply power				X	Special Requirements
48	81	Pressure measurement defect	'Print option' optional module defective	Replace 'Print option' optional module				X	Electronics
202		Extern access	Communication with the device is performed via HART	Depends on application	X				Configuration
203		All locked	Local operation is locked	Activate the digital input	X				Configuration
204		Conf. Locked	Configuration is locked	Activate the digital input	X				Configuration
205		Panel locked	Input locked	Terminate simulation.	X				Configuration
206		Simulation	Simulation active	Deactivate function in DTM or EDD	X				Configuration
207		Squawk*	'Find device' activated		X				Configuration

*Function available only via HART7

7. Maintenance

Spares available: SP8 Series filter kit

