

Electropneumatic Smart Positioner
Installation and Maintenance Instructions

1. *Index*
2. *Safety information*
3. *Technical information*
4. *Options*
5. *Installation*
6. *Electrical connections*
7. *Quick start procedure*
8. *Programming*
flow chart
9. *Programming and*
commissioning
10. *Maintenance*
11. *Default values and*
program settings
12. *Glossary of*
display data
13. *Certification*

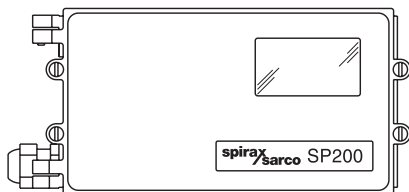

1. Index

Section	Sub-section
2. Safety information	2.1 General requirements
	2.2 Electrical safety requirements
	2.3 Electromagnetic compatibility
	2.4 Installation for hazardous areas and certification
3. Technical information	3.1 Description
	3.2 Technical data
	3.3 Materials
	3.4 Programmable functions
4. Options	4.1 Pressure gauge block
5. Installation	5.1 Mounting the SP200 positioner - General informaton
	5.2 Sequence for mounting an SP200 positioner to a linear actuator
	5.3 Sequence for mounting an SP200 positioner to a rotary actuator
	5.4 Air supply and connections
6. Electrical connections	6.1 Guidance notes
	6.2 Wiring diagrams
7. Quick start procedure	7.1 2-port valves
	7.2 3-port valves
8. Programming flow chart	
9. Programming and commissioning	9.1 SET-UP NOW
	9.2 SP200 MENU
	9.3 MANOP
	9.4 AUTOS - automatic autostroke commissioning
	9.5 SET - setting of valve functions
	9.6 TUNE - setting of valve tune functions
	9.7 RUN - automatic operation
	9.8 STRVL and RTIME - valve diagnostics
	9.9 RETRN - return to SP200 MENU in main menu
10. Maintenance and troubleshooting	10.1 Air supply quality
	10.2 Fitting replacement filter plug kit
11. Default values and program settings	
12. Glossary of display data	12.1 Main menu display functions
	12.2 Sub-menu display functions
13. Certification	

2. Safety information

2.1 General requirements

The flawless and safe operation of the SP200 positioners is reliant on proper transportation, storage, installation and commissioning by qualified personnel, proper use and careful maintenance.

Prior to installing, using or maintaining the positioner, consideration should be given to:

- The working environment.
- Safe access.
- Lighting.
- Pipeline fluid hazards.
- Temperature.
- System isolation.
- Location.

The SP200 positioner should be mounted with sufficient space to allow opening of the hinged cover and to provide access for electrical and air connections. When fitting to an actuator, ensure that the positioner will not be exposed to an ambient temperature outside the range of -10°C to +80°C. The positioner enclosure is rated to IP65 (see BS EN 60534-1 1998).

2.2 Electrical safety requirements

The SP200 is a class III product which must only be powered from Safe Extra Low Voltage (SELV) sources whether by virtue of a 4 - 20 mA control signal or from a separate power supply. Similarly all signal circuits connected to an options board must operate within the confines of SELV systems. All associated wiring must be separated from other wiring containing hazardous voltages.

2.3 Electromagnetic compatibility

The product complies with the Electromagnetic Compatibility Directive 89/336 EEC by meeting standards EN 5008-1 (Emissions) and EN 50082-2 (Industrial Immunity). This product may be affected by interference above the limits within EN 50082-2 if:

- The product or its wiring is located near a radio transmitter. The actual separation necessary will vary according to the power of the transmitter.
- Cellular telephones or mobile radios are used within approximately one metre of the product or its wiring.
- The wiring is routed alongside power cables subject to high voltage transients or current surges.

2.4 Installation for hazardous areas and certification

- General information

SP200 Smart Positioner is available for Intrinsic Safety applications, model identification is SP200is.

In case of use in hazardous areas with danger of explosion, it must be verified that the identified type of positioner fits for the classification of the zone and for the presence of flammable substances in the plant.

Model SP200is is certified by EC-type Examination Certificate N. IMQ 07 ATEX 011- EC Directive ATEX 94/9/CE with following classification:

 II 2GD

and protective system:

Ex ia IIC T6 / Ex iaD 21 T85°C (Tamb -20/+40°C)
Ex ia IIC T5 / Ex iaD 21 T100°C (Tamb -20/+65°C)
Ex ia IIC T4 / Ex iaD 21 T135°C (Tamb -20/+80°C)

2.4.1 Safety data definitions

Group II: surface plants

Category 2: fit for zone 1 Gases – zone 21 Dusts: an area in which an explosive mixture is likely to occur in normal operation

G (Gas): fit for explosive gases

D (Dust): fit for flammable dusts

Protection system (Intrinsic Safety): Ex ia for Gases
Ex iaD for Dusts

IIC : gas group IIC including Hydrogen and Acetylene

Temperature classification T6 (Maximum surface temperature = 85°C)

Temperature classification T5 (Maximum surface temperature = 100°C)

Temperature classification T4 (Maximum surface temperature = 135°C)

2.4.2 Electrical connections for IS.

For installation in classified areas it is necessary to foresee the use of certified associated apparatuses (e.g. safety barriers), with output electrical characteristics compatible with the maximum input parameters (ref. to Name-plate) of the certified SP200is positioner:

Electrical input parameter of SP200is

Circuit	Ui(V)	Ii (mA)	Pi(mW)	Ci(nF)	Li(mH)
Supply	30	100	650	2	-
Switch 1&2	15	25	65	12	-
Retransmit	30	100	650	15	-

Evaluation of the system constituted by the associated apparatus, SP200is positioner and connection cables must be done by experienced personnel only and must match the requisite of the standard EN 60079-25 for intrinsically safe systems.

In Section 6 there is an example drawing of electrical connections for Intrinsically Safe applications.

A drawing of the Name-plate is shown below

A copy of EC-Type ATEX Certificate is in 'Section 13 - Certification'.



SP200is POSITIONER IMQ 07 ATEX 011

EX ia IIC T6 / EX iaD 21 T85°C (Ta=40°C)
EX ia IIC T5 / EX iaD 21 T100°C (Ta=65°C)
EX ia IIC T4 / EX iaD 21 T135°C (Ta=80°C)



0035



II 2 GD EX-i circuit parameters

Circuit	Ui(V)	Ii(mA)	Pi(mW)	Ci(nF)	Li(mH)
supply	30	100	650	2	~0
switch 1	15	25	65	12	~0
switch 2	15	25	65	12	~0
retransmit 4÷20mA	30	100	650	15	~0

Spirax Sarco s.r.l. - via per Cinisello, 18 - 20054 - Nova milanese (MI) - Italy
tel. +39-0362-49171 Fax +39-0362-4917310

3. Technical information

3.1 Description

The SP200 smart valve positioner is loop powered from a 4 - 20 mA input signal to provide accurate adaptive positional control of pneumatic actuated linear and quarter turn valves. Precise control is maintained through valve position feedback that automatically varies the pneumatic output pressure to overcome the effects of stem friction and flow forces to maintain desired valve position. Indication of valve position is provided through a continuous digital display of % travel. Valve position feedback is retrieved by means of a non contact technology based on Hall effect. Therefore, high resolution, high reliability and vibration insensitivity are guaranteed.

The SP200 includes many smart functions that can be fully programmed through menu driven software using an integral keypad and LCD alphanumeric data. Valve commissioning is simplified through an autostroke routine and display of programming status, software travel switch status, mA input signal and valve diagnostics data. Moreover, the absence of mechanical linkages between valve stem and positioner, drastically simplifies the mounting procedure and reduces the time required. The SP200 is supplied with a NAMUR standard mounting kit for attachment to yoke or pillar mounted actuators. For quarter turn valves, a mounting kit compliant to VDI/VDE 3845 is supplied.

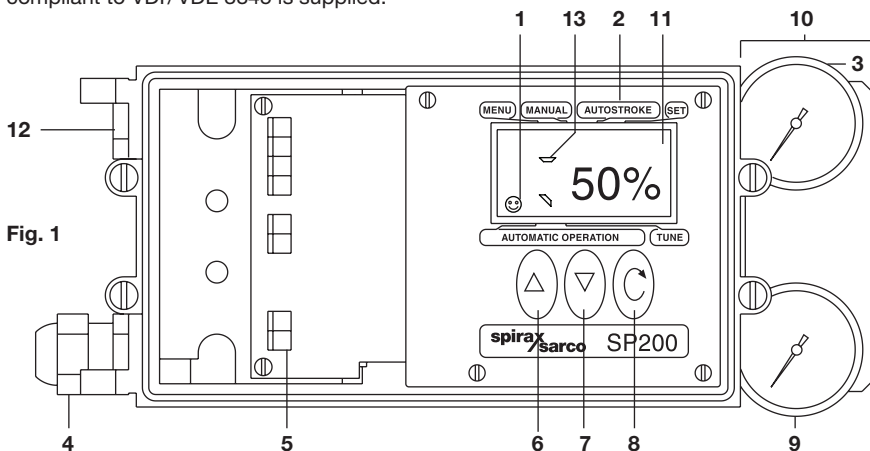

Fig. 1

No. Part

- | | |
|-----|---------------------------------------------------------------------------------------------------------------|
| 1. | ☺ indicating all OK. (! indicates an error) |
| 2. | Main menu functions with LCD flag indication |
| 3. | Signal pressure to actuator |
| 4. | Gland connection for wiring Pg 13.5 |
| 5. | Terminal block |
| 6. | Increase value or toggle value key |
| 7. | Decrease value or toggle value key |
| 8. | Enter key |
| 9. | Supply pressure to positioner |
| 10. | Optional pressure gauge block with gauges -
2 gauges for single action, 3 gauges for double action version |
| 11. | Display of programming data, mA input signal and % travel |
| 12. | Spare Pg 13.5 gland connection for wiring 4-20 mA retransmission or software switches |
| 13. | Status of software configured travel switches. |

3.2 Technical data

Input signal range	4 - 20 mA nominal	
Minimum input signal (loop powered)	3.6 mA	
Minimum air supply pressure	1.0 bar g above maximum spring range pressure (Note: For the PN5120 actuator, the supply air pressure should be set at 1.5 bar g)	
Maximum air supply pressure	6.0 bar g	
Air quality	Air supply must be dry, oil and dust free to ISO 8573-1 class 2:3:1	
Output pressure	0 to 100% supply pressure	
Stroke range	Linear valves	10 mm to 100 mm
	Quarter turn valves	5° to 120°
Action	Single action / fail vent	
	Double action / fail vent output 1, fill output 2	
Operating temperature	-10°C to +80°C	
Maximum air flow	4.2 normal m ³ /h at 1.4 bar g or	
	8.5 normal m ³ /h at 6 bar g	
Steady state air consumption	Less than 0.035 normal m ³ /h	
Air connections	Screwed ¼" NPT	
Cable gland	Pg 13.5	
Electrical connections	Spring clamp terminals for 0.2 to 1.5 mm ² wire	
Enclosure rating	IP65	
Characteristic	Linear, Equal % (ratio 1:50) or Fast opening (ratio 50:1)	
Resolution (maximum)	0.1% F.S.	
Shipping weight	3.2 kg	

3.3 Materials

Part	Material	Finish
Case and cover	Die cast aluminium	Anti-corrosive paint to RAL5010
Magnet bracket	Die cast aluminium	

3.4 Model SP200is – ATEX certification

EC-type Certificate N. . IMQ 07 ATEX 011

Classification  II 2GD

Ex ia IIC T6 / Ex iaD 21 T85°C (Tamb -20 to +40°C)

Ex ia IIC T5 / Ex iaD 21 T100°C (Tamb -20 to +65°C)

Ex ia IIC T4 / Ex iaD 21 T135°C (Tamb -20 to +80°C)

3.5 Programmable functions

Autostroke	Automatic commissioning routine
Valve type	2-port or 3-port
% travel	Selectable 0 to 100% or 100% to 0% depending on valve / actuator configuration
Control action	Direct or reverse action (4 - 20 or 20 - 4 mA)
Travel limits	Setting of minimum and maximum travel limits (valve open and valve close % travel)
Displayed travel %	0 - 100% displayed over mechanical travel limits or MIN-T/MAX-T adjusted settings
Signal span	4 - 20 mA or split ranged (minimum span 4 mA)
Dead-band	Positional accuracy (minimum 0.2% to max. 10% of valve travel)
Tight shut-off	Fully vent or inflate at preset input signals
Characteristic	Linear, = % or fast opening input signal to valve travel relationship
Travel time	Slows down valve opening or closing
Travel switches	Software travel switch setting (range 0 - 100%)
Reset	Resets all programmed values to default settings
Calibrate	Centering
Input signal	Visualisation of input mA signal
Auto operation / vent	Option of automatic operation or vent (actuator) whilst reprogramming
Data logging	Diagnostic record of total number of valve strokes and completed hours run time

4. Options

4.1 Pressure gauge block

An optional pressure gauge block (Figure 2) can be fitted onto the SP200 positioner which includes two pressure gauges indicating air supply pressure and output air signal pressure to the actuator. For double action valves the gauge block includes 3 pressure gauges indicating: air supply pressure, output 1 air signal and output 2 air signal. The pressure gauge block can be retrospectively fitted using 2 off M5 Allen screws. Ensure that the gauge block air connection 'O' rings are correctly located before tightening.

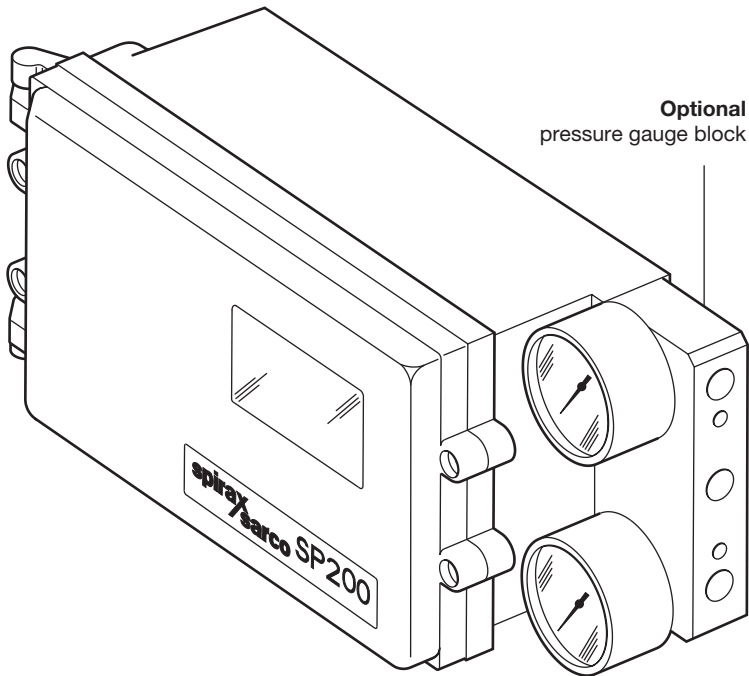

Fig. 2

5. Installation

5.1 Mounting the SP200 positioner - General information

Preliminary check of valve and actuator assembly - A preliminary check should be carried out on the valve and actuator assembly prior to mounting and commissioning the SP200 positioner to confirm smooth movement of the stem. This can be performed by providing an air supply directly from a filter/regulator to the actuator. The air supply pressure should be gradually increased to progressively move the stem through its full travel. Any friction or jerky movement of the stem should be investigated prior to commissioning the SP200.

5.1.1 The SP200 is supplied with a NAMUR standard fixing kit for linear actuators (yoke or pillar) or with a VDI/VDE 3845 compliant mounting kit for rotary actuators.

5.1.2 Permitted and forbidden mounting positions

The SP200 will not work if mounted on its side or upside down. The positions marked with an "X" are not allowed. In case this cannot be avoided, please contact Spirax Sarco. It is possible to ask for a special calibration when you place the order. In this case the positioner shall be mounted only in the chosen position..

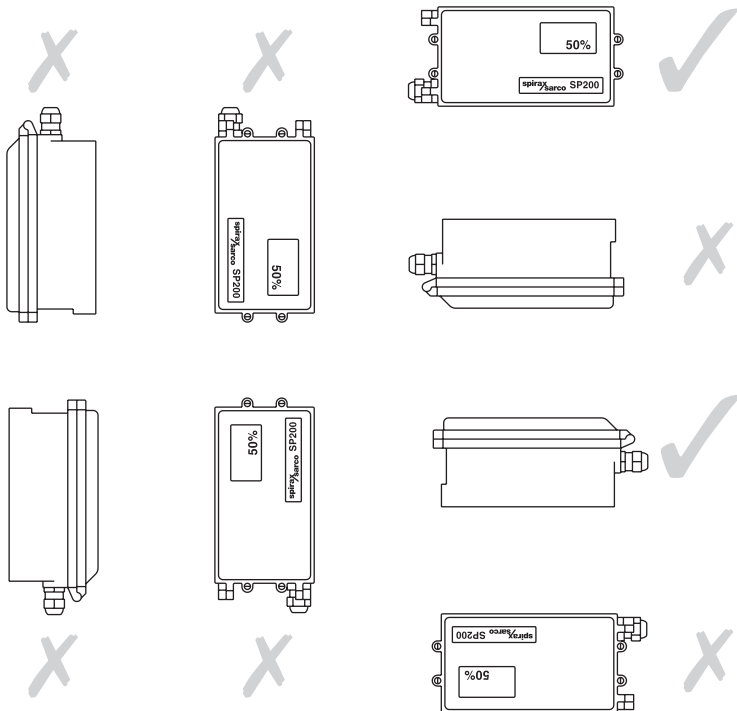

Fig. 3 SP200 mounting

5.1.3 The SP200 has an enclosure rating of IP65 and should be installed in a location that will not exceed its ambient temperature limits of -10°C minimum and +80°C maximum.

5.1.4 Before fitting and commissioning the SP200 positioner ensure that the valve and actuator are correctly assembled. Refer to the valve and actuator Installation and Maintenance Instructions for details.

5.2 Sequence for mounting an SP200 positioner to a linear actuator

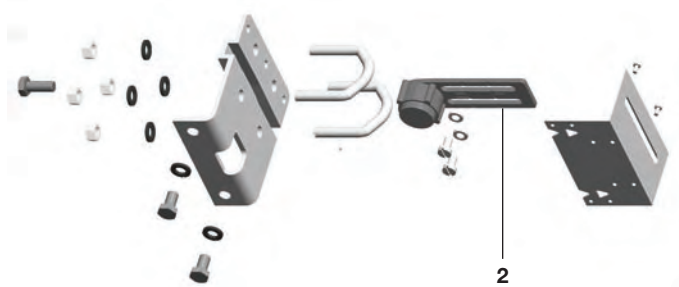
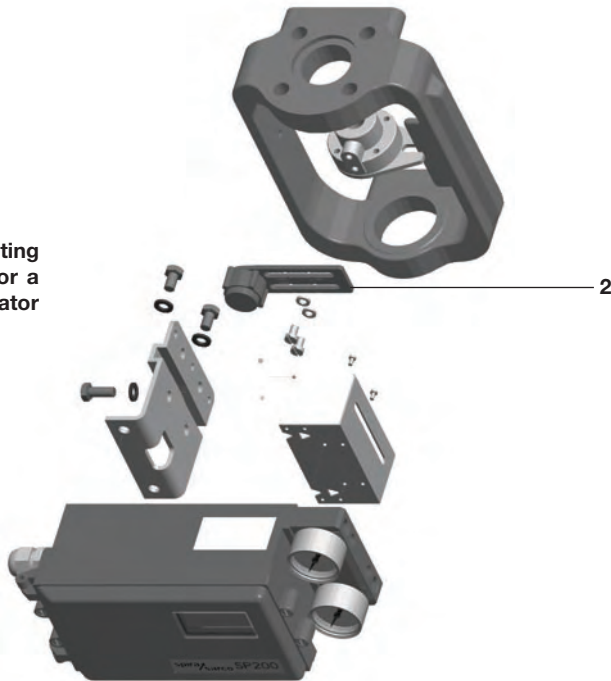

Fig. 4 Pillar mounting kit for a linear actuator

5.2.1 Loosely attach the magnet bracket (2) to the valve/actuator connector (refer to Figures 4 and 5). Be sure it is positioned horizontally (as shown in Figure 5).

Fig. 5
Yoke mounting assembly for a linear actuator



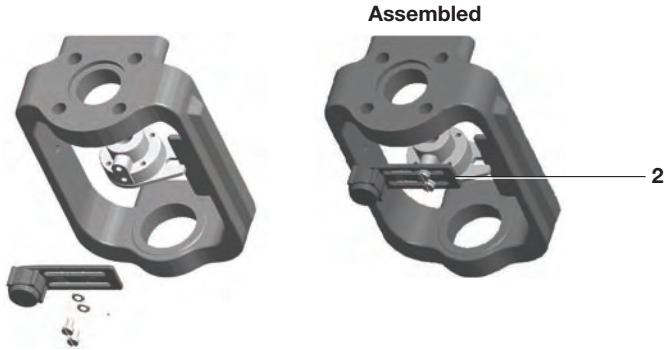

Fig. 6

5.2.2 Slide the bracket (2) to the left or to the right (Figure 6) till the correct position is achieved. If you're using a Spirax Sarco actuator the correct position is impressed on the magnet bracket (Figure 7).

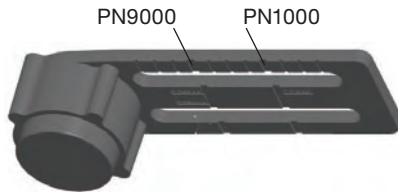

Fig. 7 Bracket markings

5.2.3 If you're not using a Spirax Sarco actuator, slide the bracket till the distance 'A' between the center of the magnet and the inner side of the mounting plate is 25 mm (Figure 8).

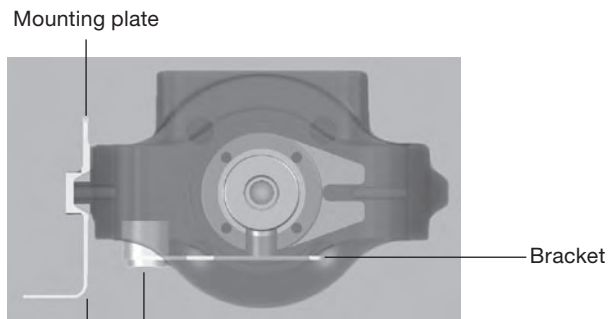

Fig. 8

→ A ← Distance between the mounting plate and magnet

Center of the magnet

5.2.4 Loosely attach the positioner mounting plate to the actuator as shown in the following pictures: for the pillar actuator (Figure 9), and for the yoke actuator (Figure 10).



Fig. 9 Pillar actuator assembly

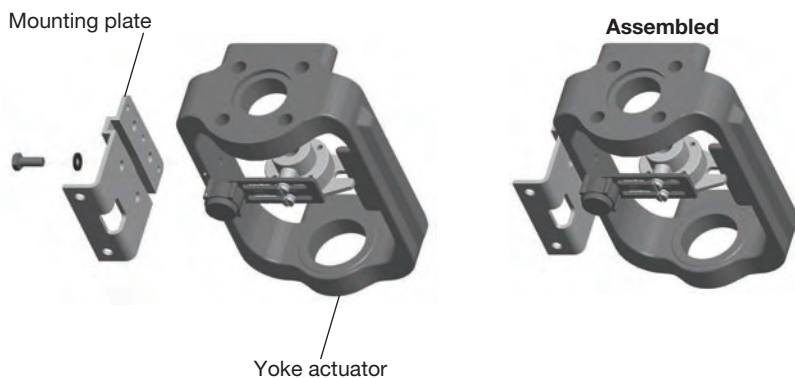

Fig.10 Yoke actuator assembly

5.2.5 Locate the protection plate onto the back of the SP200 positioner housing and fix in place (Figure 11).

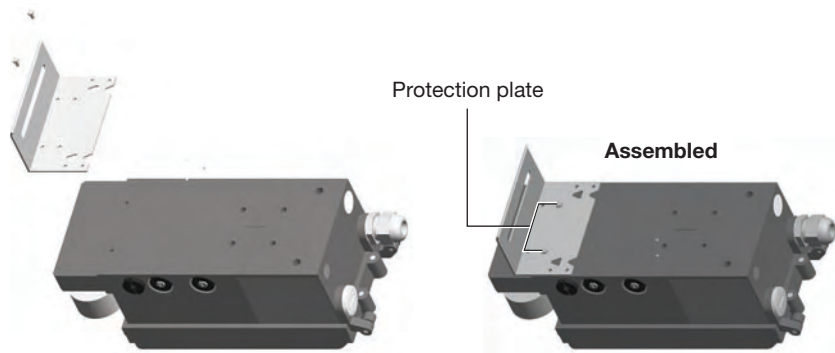

Fig. 11

5.2.6 Attach the positioner mounting plate to the positioner as shown in Figure 12.

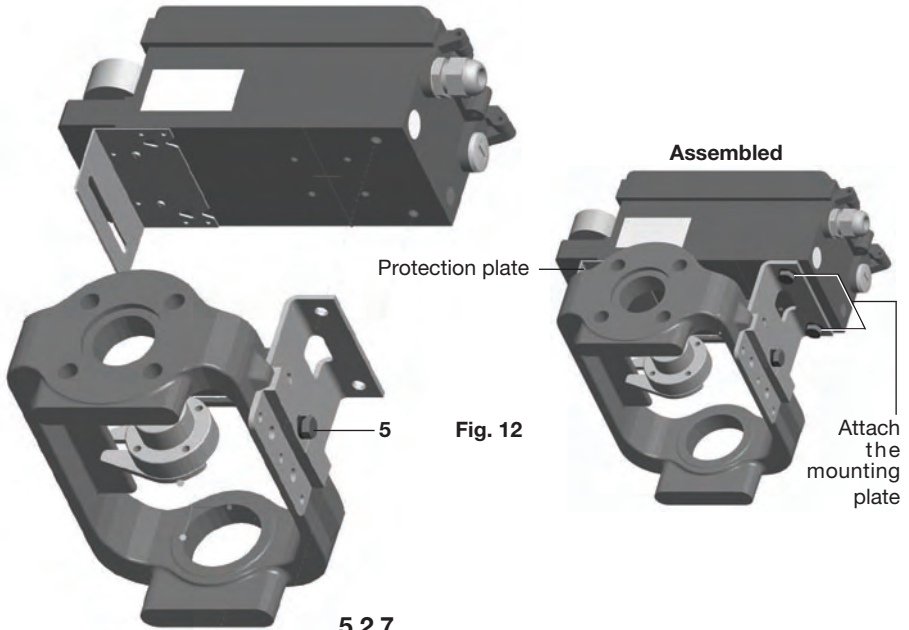

Fig. 12

5.2.7

Adjust the vertical position of the SP200 positioner and mounting plate assembly, by sliding it up or down on the pillar style actuators, ensuring that the positioner is roughly centred on the actuator/valve stroke (Figure 10).

Even if this is the ideal condition, it's not mandatory. In fact, as shown in Figure 13, the only necessary condition for correct operation is that the stroke of the magnet (dimension **B**) lay inside the sensor operating linear range (dimension **A**), i.e. the vertical dimension marked on the case of the positioner.

5.2.8

When the SP200 positioner and mounting plate assembly is correctly positioned, tighten the hexagon headed screw (5) on the yoke mounted actuator (Figure 12) to 10 - 12 N m and tighten the 'U'bolt nuts (6) on the pillar mounted actuators (Figure 14) to 10 - 12 N m.

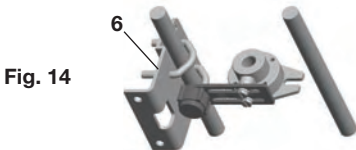

Fig. 14

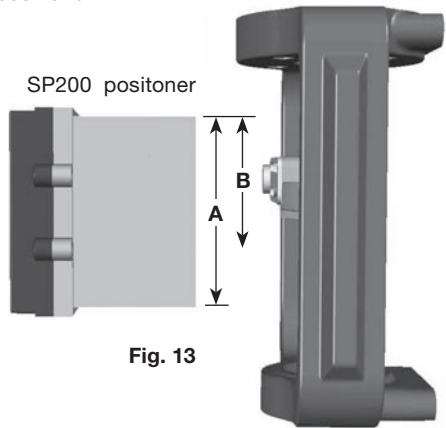

Fig. 13

5.3 Sequence for mounting an SP200 positioner to a rotary actuator

5.3.1 Assembly for fitting an SP200 on to a ¼ turn valve.

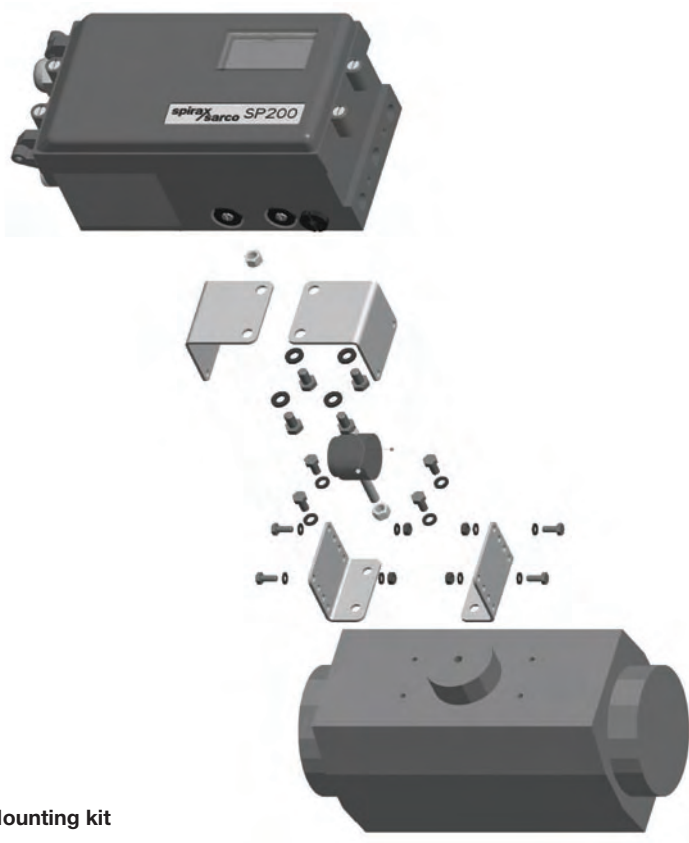

Fig. 15 Mounting kit

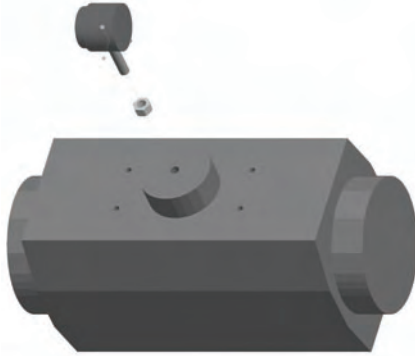

Fig. 16

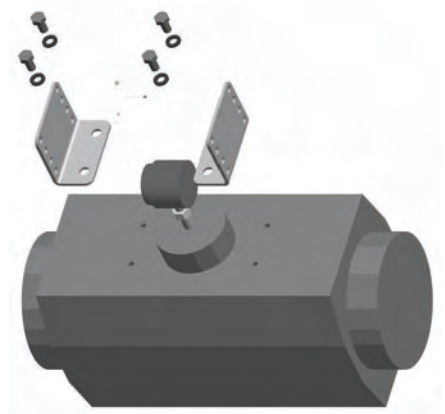
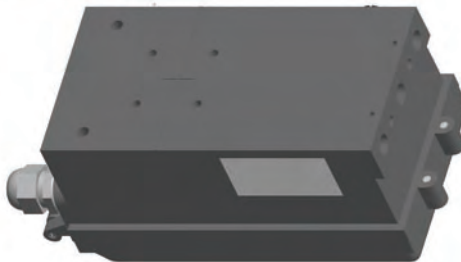

Fig. 17



Fig. 18



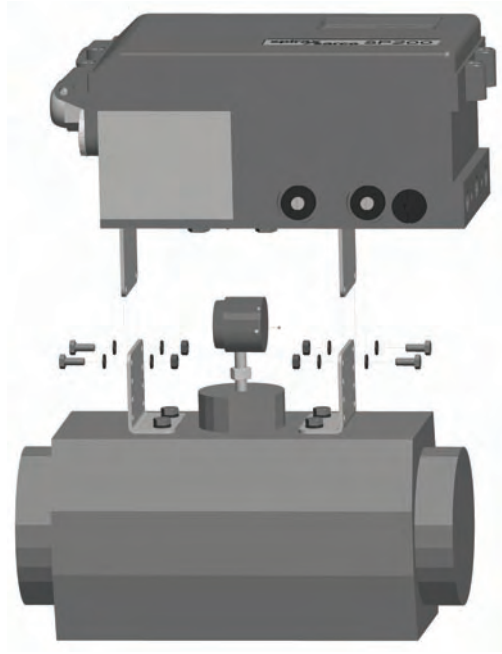

Fig. 19

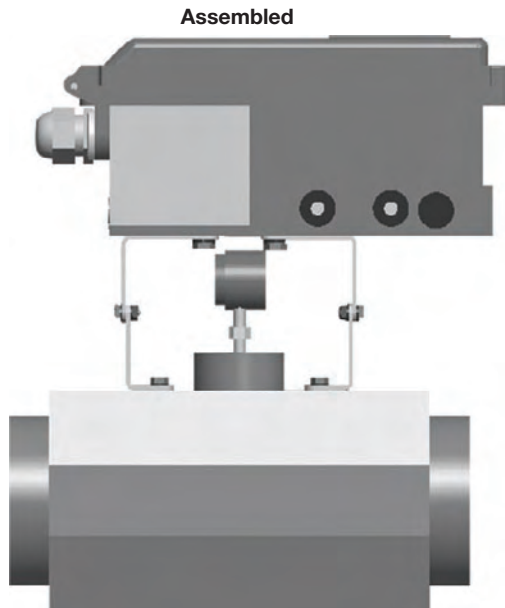

Fig. 20

5.3.2 Adjust the magnet orientation as illustrated in Figures 21 and 22 and tighten the bolt to fix the magnet into position. There should be a distance of between 5 and 14 mm between the magnet and the positioner.
 Refer to Figure 21 for actuator with clockwise rotation.
 Refer to Figure 22 for actuator with anti-clockwise rotation.
 In fact, in this way the magnet movements will always be comprised in the sector between the directions **C** and **D** which delimit the operating area of the Hall sensor.

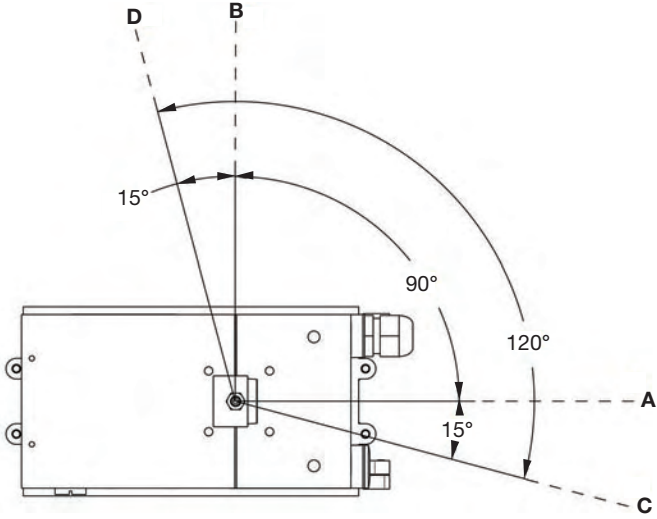

Fig. 21 View from the bottom of the positioner - Magnet orientation for clockwise actuator.

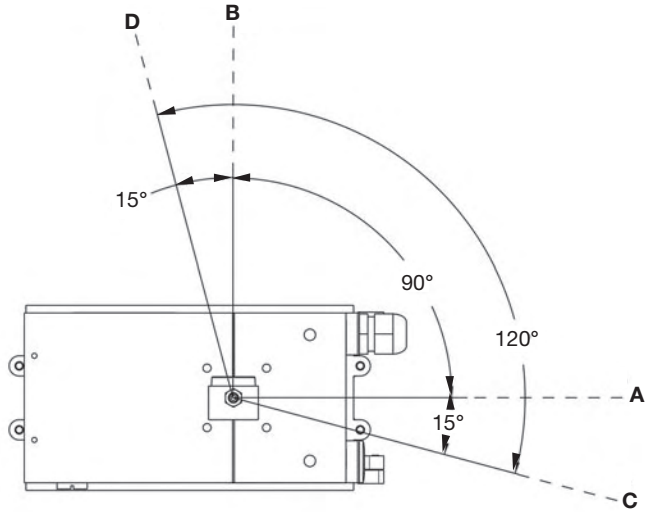

Fig. 22 View from bottom of the positioner - Magnet orientation for anti-clockwise actuator.

5.4 Air supply and connections

WARNING: Supply air pressure must not exceed the maximum allowable air pressure of the actuator. Air connections should be 1/4" NPT for air supply (supply) and output signal to actuator (output 1 and output 2 for double action applications) as shown in Figure 23. The supply air should be between 1.4 bar g minimum and 6 bar g maximum and be oil and dust free to IEC 60770. Mains air supply may sometimes contain traces of dirt, rust, water, oil and other deposits with the potential for contaminating the internals of the positioner. It is therefore essential that a filter / regulator is fitted in the mains air supply to the positioner. The filter / regulator should have a coalescing filter such as a Spirax Sarco type MPC2, or suitable compressed air pipework is used.



Fig. 23

6. Electrical connections

6.1 Guidance notes on wiring installation

For heavy industrial applications it is recommended to use screened cables or signal cables run in metal conduit. Failure to do so could result in positional errors of up to $\pm 5\%$ in an RF field excess of 10 V/m. If screened cables are used, ensure that the screen is connected to the local earth at one end with a connection resistance of less than 1 ohm.

For light industrial applications where RF fields do not exceed 3 V/m unscreened cables may be used.

Cabling should be installed in accordance with BS 6739 - Instrumentation in Process Control Systems: Installation design and practice or local equivalent.

6.2 Wiring diagrams

6.2.1 Single loop applications

(see Section 6.2.2 for Multi-loop applications)

The SP200 is loop powered using the 4 - 20 mA input signal source providing a minimum signal of 3.6 mA can be maintained.

Minimum current = 3.6 mA

Maximum current = 30 mA

Voltage drop = 10.6 V @ 20 mA

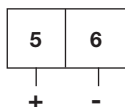

Fig. 24

4 - 20 mA signal

6.2.2 Multi-loop applications

Loop powered multi-positioner connections

In a loop powered application, the 4 - 20 mA signal must be capable of supplying a minimum of 10.6 V per positioner at 20 mA. In a split range application the signal source loop must be capable of supplying sufficient voltage, i.e. 22 V are enough to power 2 positioners (Figure 16).

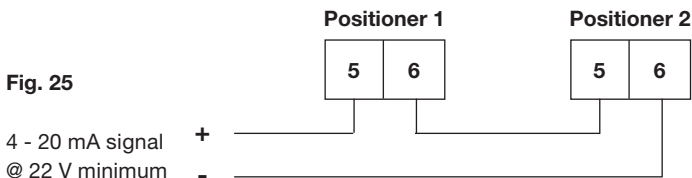

Fig. 25

4 - 20 mA signal
@ 22 V minimum

In terms of impedance, this means that in split range application, the load in the loop at 20 mA is 1060 Ohm. The impedance of a single SP200 is 530 Ohm at 20 mA. A typical controller might not be able to drive such a impedance load, hence a different approach is required.

A 4-20 mA current splitter can provide a solution to this problem for further information please contact Spirax Sarco.

6.2.3 Travel switches- and 4-20 mA retransmission wiring digrams

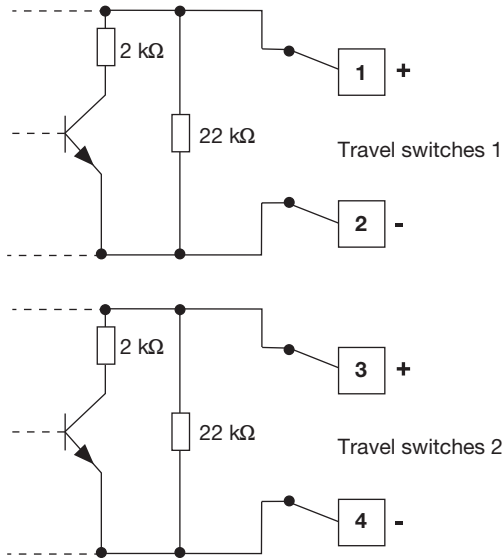

Fig. 26 Software switches

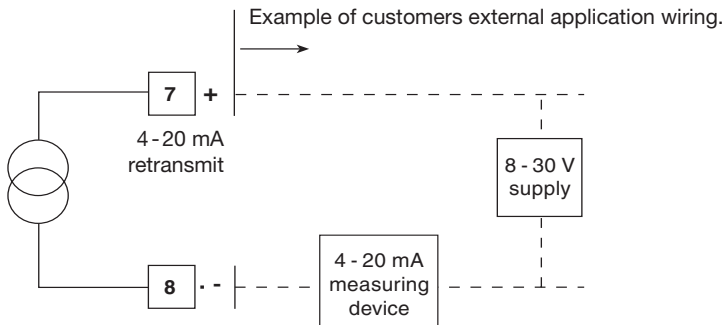

Fig. 27 4 - 20 mA retransmit

Table 1

Ratings	Supply	Impedance	On current	Off current
TS1 travel switch	18 - 30 Vdc	1.8 kΩ	13 mA	1 mA @ 24 V
TS2 travel switch	18 - 30 Vdc	1.8 kΩ	13 mA	1 mA @ 24 V
4 - 20 mA	8 - 30 Vdc	-	-	-

6.2.4 Wiring for intrinsic safe applications

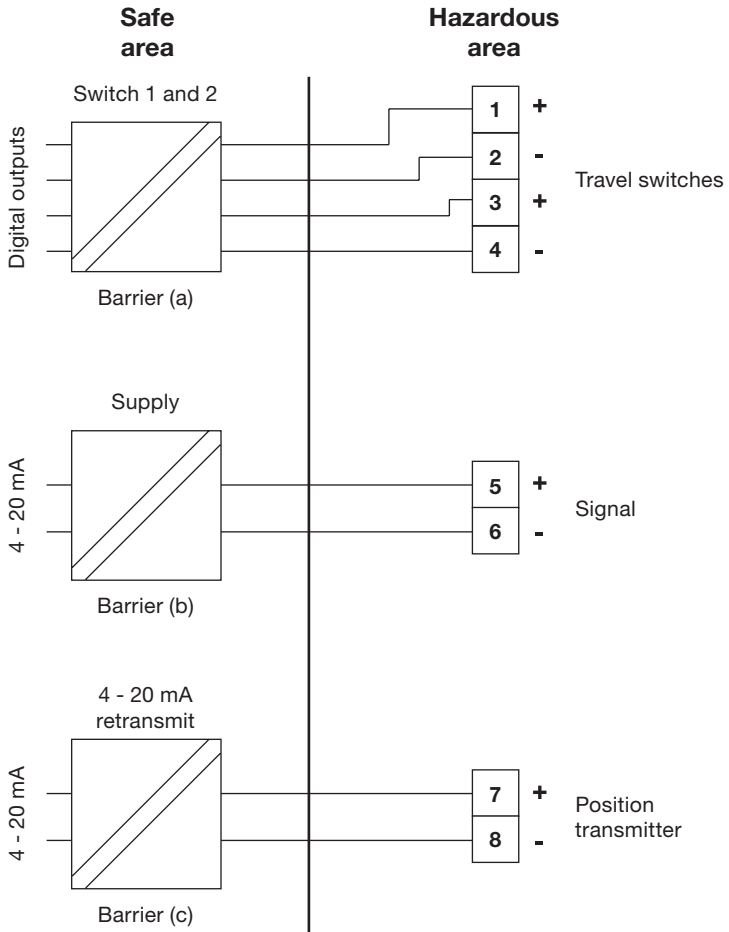

Fig. 28 Example of electrical connections for Intrinsically Safe applications

Output parameter for Barrier (b) and (c) $U_o \leq 30 \text{ V}$, $I_o \leq 100 \text{ mA}$, $P_o \leq 650 \text{ mW}$

Output parameter for Barrier (a) $U_o \leq 15 \text{ V}$, $I_o \leq 25 \text{ mA}$, $P_o \leq 65 \text{ mW}$

7. Quick start procedure

7.1 2-port valves

The following applies to positioners fitted to 2-port valves having plug above the seat and fitted to pneumatic actuators having a direct acting (DIR) 4 - 20 mA input signal and excludes the setting of any additional program functions (i.e. default value only).

Note: For PN5100 and PN6100 series actuators an additional programming step is required. (Refer to Section 9.5.2).

7.1.1 The positioner should be correctly assembled as described in Section 5 and Section 6 and supplied with mains air and signal pipework as described in Section 5.4.

7.1.2 Provide a minimum input signal of 3.6 mA to the positioner.
SET-UP NOW should be displayed.

7.1.3 Ensure that upstream isolation valves are closed.
Press and hold **C** key for 3 seconds to advance to **SP200 MENU**.
The display will count down the 3 seconds.

7.1.4 Press **▼** to advance to **MANOP**.

7.1.5 Press and hold **C** key for 3 seconds to enter manual control mode **MCTL**.

7.1.6 In manual control press and hold **▲** or **▼** keys to drive the valve stem up or down.
Check for any obstructions of valve movement.
The display will indicate **FILL** or **VENT** as appropriate.
Any obstruction should be investigated before proceeding to Section 7.1.7.

7.1.7 Press **C** key to return to **MANOP** in main menu.

7.1.8 Press **▼** key to advance to **AUTOS** autostroke mode.

7.1.9 Press and hold **C** key for 3 seconds to start the autostroke routine.
This will take approximately 2 minutes to complete.

! displayed indicates an incomplete or unsuccessful autostroke.

The routine can be aborted at any time by pressing **C** key once.

If autostroke is aborted during operation **ABORT** will be displayed and **!** to indicate incomplete autostroke.

On completion the program will automatically return to **AUTOS** in main menu.

A **😊** will be displayed if successful autostroke has been completed. It is now possible to advance to **RUN** in main menu.

7.1.10 Press **▼** key three times to advance to **RUN** in main menu.

7.1.11 Press and hold **C** key for 3 seconds to commence automatic operation.
The valve will move to a control position related to the input control signal.
The percentage valve travel will be displayed **%**.
The positioner cover can now be closed and cover screws tightened.

7.2 3-port valves (with travel setting (TRAVL) 0 - 100%, refer to Figures 27 and 28)

Proceed as above up to Section 7.1.9.

7.2.1 On completion of a successful autostroke press the ▼ key once to advance to **SET** in main menu.

7.2.2 Press **C** key once to advance to **VALVE TYPE**.
Press ▲ key to indicate **VALVE 3-PORT**.

7.2.3 Press **C** key to select **VALVE 3-PORT**. Continue to press **C** key to return to **SET** in main menu.

7.2.4 Press ▼ key twice to advance to **RUN** in main menu. Proceed as described in Section 7.1.11.

8. Programming flow chart

Fig. 29

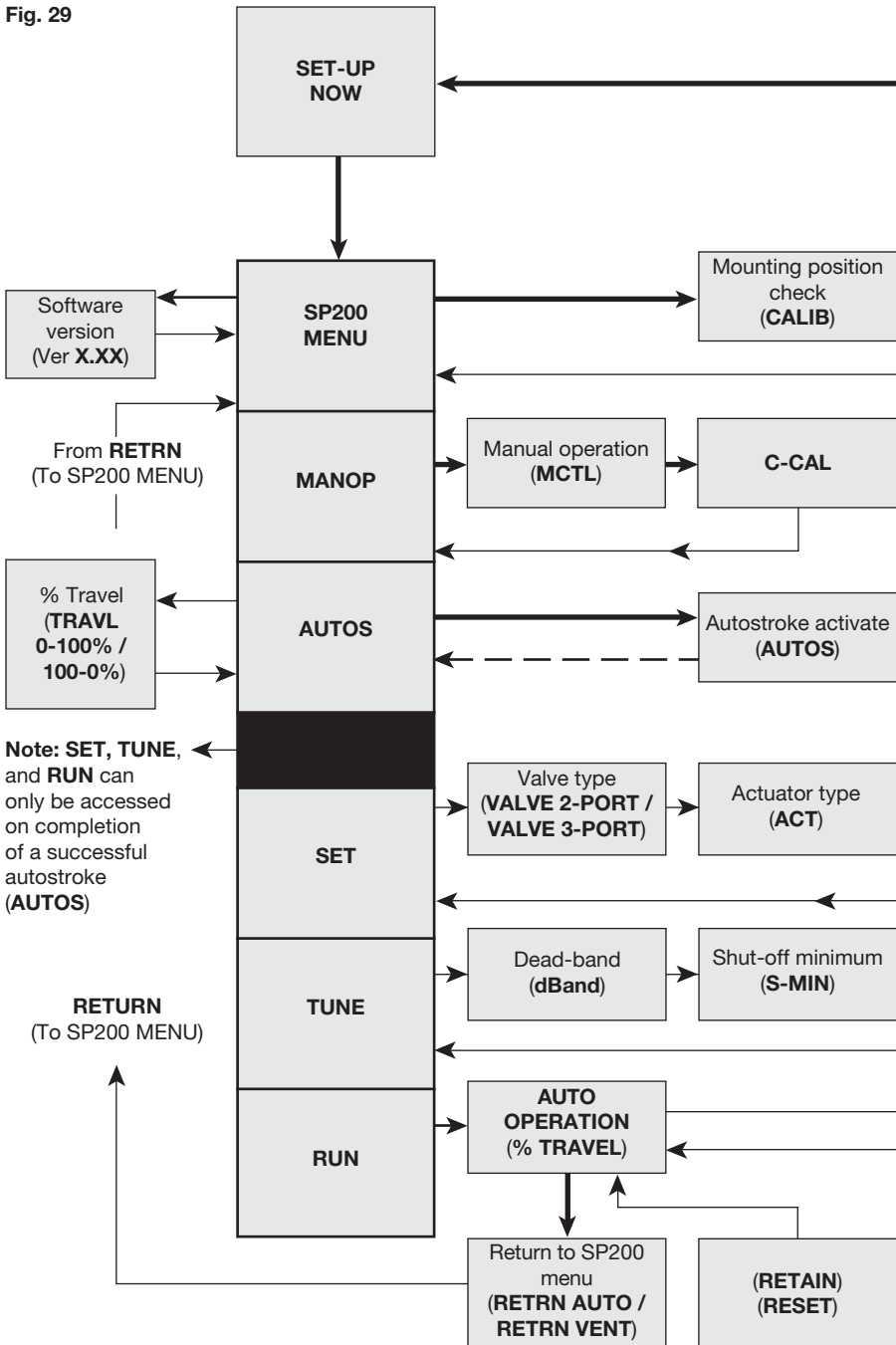

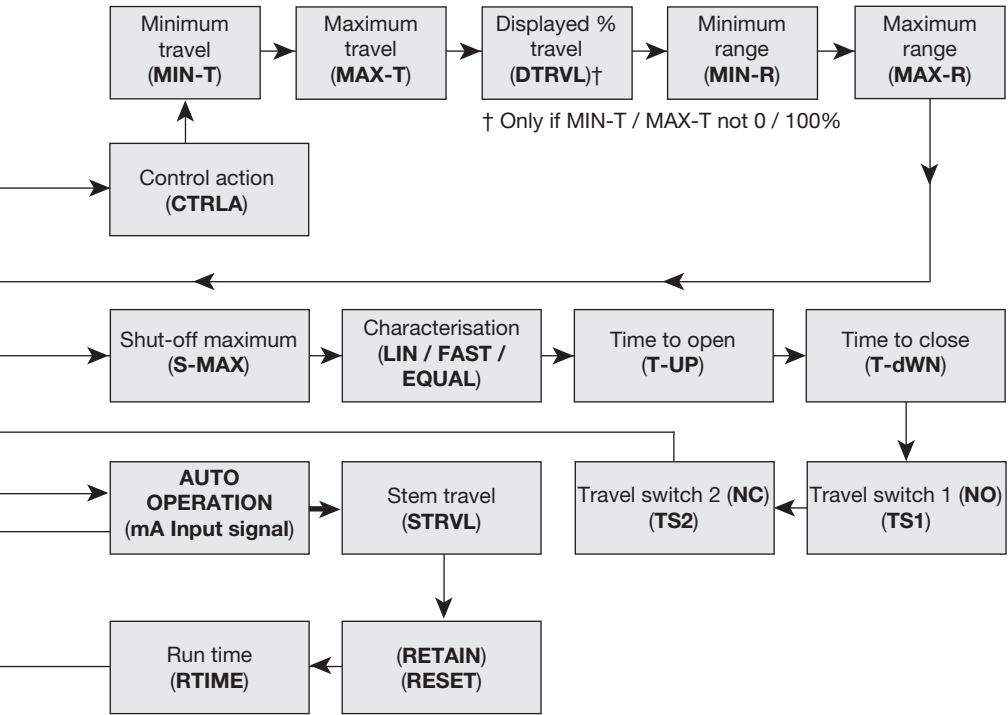
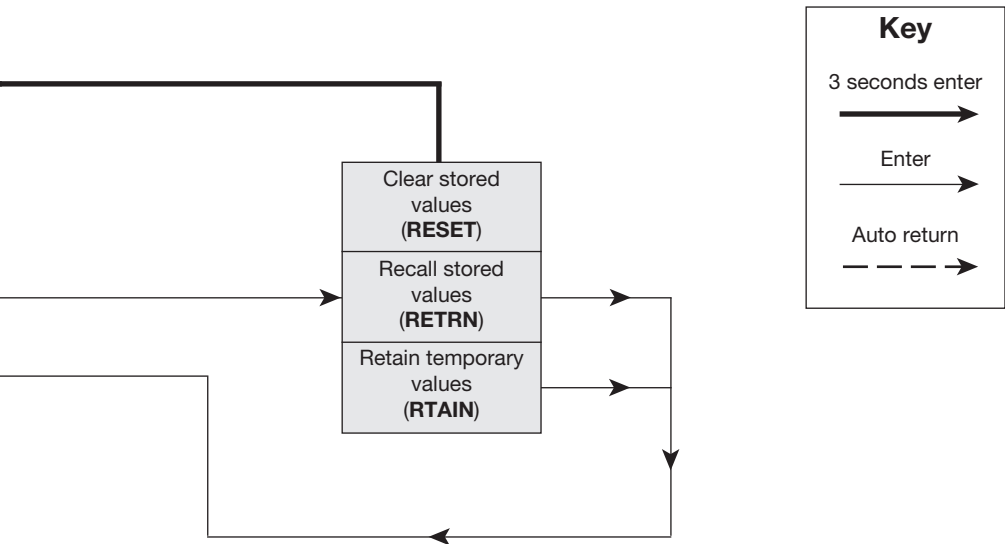

– 9. Programming and commissioning –

9.1 Set-up now

Programming notes

The positioner fitted to this control valve requires programming. A minimum input signal of 3.6 mA is required to power the positioner. To program the positioner it is necessary to enter **SP200 MENU** and carry out an autostroke commissioning routine (**AUTOS**) prior to putting the control valve into automatic operation.

A flow chart is included in Section 8 to guide you through the procedure. The display provides a flag indication of the active main menu function.

To enter **SP200 MENU** press and hold **C** key for 3 seconds. The display will count down the 3 seconds.

Commissioning notes

Main menu functions include:

SP200 MENU View software version, mounting position check, reset default values.

MANOP Manual control of valve movement (Actuator inflation / deflation).

AUTOS Automatic valve commissioning. Provides selection of % travel display.

SET Setting of valve type, control action, travel limits and input signal span.

TUNE Setting of deadband, tight shut-off, lift characterisation, travel time and software switches.

RUN Activates automatic operation plus input signal, total valve strokes and total run time. Also provides route for returning to **SP200 MENU**.

Note: **SET**, **TUNE** and **RUN** functions are restricted and can only be accessed on completion of a successful autostroke routine (**AUTOS**).

9.2 SP200 MENU

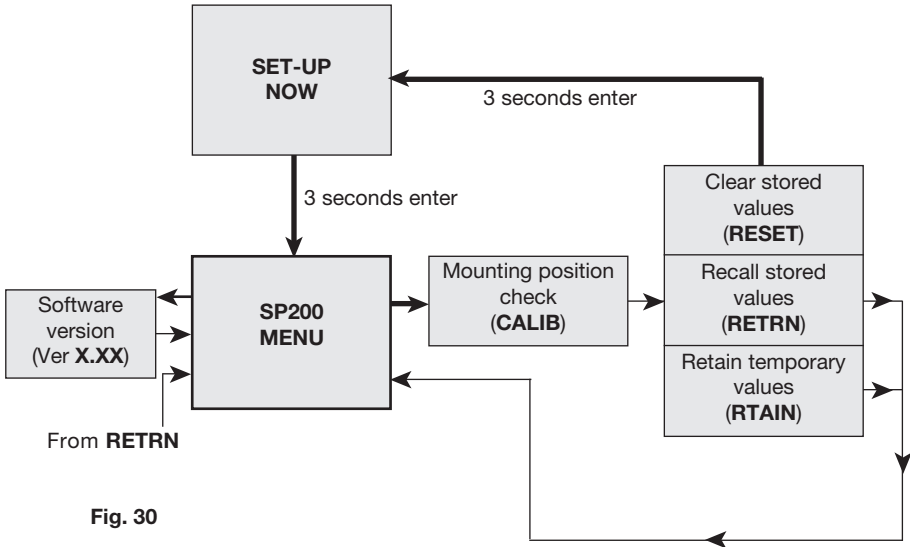

Fig. 30

Programming notes

You are now in **SP200 MENU**.

SP200 functions include:

1. Visualisation of the embedded software version (**VER--**).
2. Positional setting (**CALIB**).
3. Resetting of programmed values to default settings (**RESET**).
4. To retain settings in the temporary memory (**RTAIN**).
5. Returning to previously stored settings (**RETRN**).

To check the setting (**CALIB**) press and hold **C** key for 3 seconds. The display will count down the 3 seconds. **CALIB** also provides access to **RESET / RTAIN / RETRN** functions.

To view the embedded version of software (**VER--**) press **C** key. To advance to manual operation (**MANOP**) press **▼** key.

9.2.1 VER --- software version

Programming notes

To view the version of the embedded software (**VER--**) press **C** key.

Press **C** key to return to **SP200 MENU**. The display will automatically return to **SP200 MENU** after 10 seconds.

9.2.2 CALIB - mounting position calibration

Programming notes

To access **CALIB** press and hold **C** key for 3 seconds. The display will count down the 3 seconds. You are now in calibrate mode. The LCD shows in % the magnet position in respect to the sensor board of the positioner, without any offset or scale up or down.

When the LCD shows 0% the magnet is positioned near the bottom of the positioner's case.

At 50% the magnet will be in front of the cross impressed on the back of the positioner.

At 100% the magnet will be roughly aligned with the top of the positioner's case.

Desired setting is 50% with the valve at half stroke. The **▲** and **▼** keys can be used to manipulate the actuator inflation. In this way it is possible to check the mounting position and if necessary change it and then check again to get the positioner well centred.

Press **C** key advance to **RESET / RTAIN / RETRN**.

9.2.3 RETRN - RTAIN - RESET

Programming notes

Provides the facility to restore previously stored values (**RETRN**), to retain values stored in the temporary memory (**RTAIN**) or to reset all values to factory default settings (**RESET**). Press ▲ and ▼ keys to select **RETRN**, **RTAIN** or **RESET**. To advance proceed as follows:

RETRN

To cancel any temporary changes to programmed values select **RETRN** and press C key to return to **SP200 MENU**.

RTAIN

To retain temporary changes to programmed values select **RTAIN** and press C key to return to **SP200 MENU**.

RESET

Provides the facility to reset all values to factory default settings and return to **SET UP NOW**. Press and hold C key for 3 seconds. The display will count down the 3 seconds.

Commissioning notes

RETRN

If changes have been made to program values they will be held in the temporary memory. To retain changes in the permanent memory it is necessary to advance to **RUN** in the main menu and press and hold C key for 3 seconds. The display will count down the 3 seconds. **If you do not wish to retain temporary changes** select **RETRN** and press C key to return to **SP200 MENU**.

RTAIN

If changes have been made to programmed values they will be held in the temporary memory. If you wish to retain these changes select **RTAIN** and press C key to return to **SP200 MENU**. **To retain temporary changes in the permanent memory** advance to **RUN** in the main menu and press and hold C key for 3 seconds. The display will count down the 3 seconds.

RESET

Resetting to default values (refer to Section 9 for default values) should be used if it is intended to use the positioner on a different control valve. If the SP200 positioner has been moved on its mounting or is to be fitted on a different control valve it will be necessary to undertake a new autostroke (**AUTOS**).

RESET to factory default settings can also be used if it is required to recommission the valve.

To reset to factory default values select **RESET** and press and hold C key for 3 seconds. The display will count down the 3 seconds.

9.3 MANOP

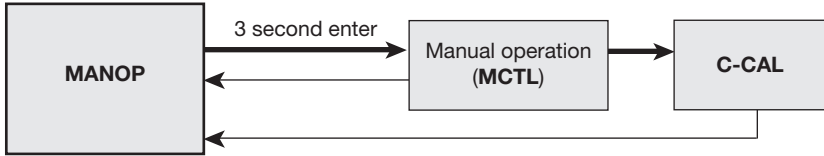

Fig. 31

Programming notes

Press and hold **C** key for 3 seconds to enter manual control mode (**MCTL**). The display will count down the 3 seconds.

Press the **C** key to enter the current calibration mode (**C-CAL**). Press **C** to return to **MANOP**.

In **MANOP** press **▼** key to advance to autostroke (**AUTOS**).

Commissioning notes

Before initiating an autostroke commissioning (**AUTOS**) use manual control (**MCTL**) to manually fully inflate and deflate the actuator to ensure there are no obstructions to the full valve travel movement.

Manual control is also useful during normal operation to manually control the valve position as a commissioning aid or in the event of input signal failure.

9.3.1 MCTL - manual control

Programming notes

Manual control enables the actuator to be manually inflated or deflated. Press **▲** key to inflate actuator and **▼** key to deflate the actuator. Press and hold **▲** or **▼** key to accelerate action.

Prior to undertaking an **AUTOS** the display will indicate **FILL** or **VENT**.

On completion of **AUTOS** the display will indicate % valve travel.

Manual control (MCTRL) - Tight shut-off function

Press and hold the **▼** key to drive the valve to its closed position. At 0% travel the **!** will flash to indicate limit of travel. To initiate tight shut-off release the **▼** key and press **▼** again. The actuator will be vented of air to provide dead tight shut-off. This also applies to the 100% valve position by pressing and releasing the **▲** key and pressing **▲** again to inflate the actuator to provide dead tight shut-off.

Manual control (MCTRL) - Travel limits

When operating in manual control any travel limit settings will be overridden therefore it is possible to manual position the valve through its full 0 to 100% travel as measured in autostroke (**AUTOS**).

Commissioning notes

Before initiating an autostroke commissioning routine (**AUTOS**) the actuator should be manually fully inflated and deflated to ensure there are no obstructions to the full valve travel movement.

Manual control is also useful during normal operation to manually control the valve position as a commissioning aid or in the event of input signal failure.

9.3.2 C-CAL - current calibration

Programming notes

C-Cal provides a simple way to make a fine calibration of the input current signal (4 - 20 mA).

To perform the calibration:

1. Enter **C-CAL** and press the ▼ key, then press the **C** key.
2. Generate a **4 mA** input signal and press **C**
3. Generate a **12 mA** input signal and press **C**
4. Generate a **20 mA** input signal and press **C**

If '**ERROR**' is displayed the calibration routine is aborted. The value of the generated signal is too far from the expected one. Be sure that a 4 mA, 12 mA or 20 mA signal is generated as required. Press **C** to return to **C-CAL**.

If '**OK**' is displayed the calibration has succeeded. Press **C** to return to **C-CAL**.

Where possible current calibration should be overtaken, to guarantee a perfect match between the input current generated and the reading of the SP200.

Let's assume that the table below show the input signal generated by a PLC or DCS versus the input signal read by the SP200.

Setpoint	Input current from PLC	Current read from SP200
0%	3.8 mA	3.8 mA
50%	12 mA	12.2 mA
100%	20 mA	20.2 mA

Hence when the setpoint is 0% the PLC generates a 3.8 mA instead of 4 mA.

After C-CAL is executed the SP200 recalibrates the current read to compensate the error.

Setpoint	Input current from PLC	Current read from SP200
0%	3.8 mA	4 mA
50%	12 mA	12 mA
100%	20 mA	20 mA

In this way a perfect match is achieved between the setpoint of the PLC and the setpoint of the of the SP200 (i.e. the input current read by the SP200).

9.4 AUTOS - automatic autostroke commissioning



Fig. 32

Programming notes

AUTOS provides access to:

1. Autostroke commissioning (**AUTOS**).
2. % travel display (**TRAVL**).

AUTOS

Autostroke provides an automatic commissioning routine which will take approximately 1 to 3 minutes to complete.

Press and hold **C** key for 3 seconds to start autostroke. The display will count down the 3 seconds. When autostroke is active a flashing **AUTOS** message will be displayed.

On completion of a successful autostroke the programme will automatically return to **AUTOS** in the main menu and a ☺ will be displayed. In the event of an unsuccessful autostroke routine a flashing **!** will be displayed.

If during **AUTOS** inconsistent data is obtained due to mechanical problems, the autostroke procedure will be terminated and **ABORT** will be displayed.

It is also possible to immediately abort during an autostroke routine by pressing the **C** key. **ABORT** will be displayed together with a flashing **!**.

Error messages:

ERROR 1 Indicates a wrong mechanical coupling between positioner and actuator. Check the mounting is correct.

ERROR 2 Indicates that there is insufficient air pressure to achieve valve movement. Check that the air supply is adequate to overcome the actuator spring force. Fitting of a gauge block will aid the commissioning procedure.

ERROR 3 Indicates that the actuator will not deflate. Check that there is no obstruction preventing the stem travel or air venting from the actuator.

ERROR 4 indicates that the stroke measured is less than the minimum stroke allowed - 10 mm for linear valves, and 5° for quarter turn valves (output 1 and output 2 for double action applications).

ABORT indicates mechanical problems have occurred during the Autostroke procedure or the **C** key has been pressed during Autostroke to abort the procedure.

On completion of a successful autostroke it will be possible to advance to **SET**, **TUNE** and **RUN** functions in the main menu. Press the ▼ key to advance to these functions.

Commissioning notes

Prior to undertaking an autostroke routine, manual operation should be used to fully inflate and deflate the actuator to ensure there are no obstructions to the full valve movement. Autostroke is an automatic commissioning routine that checks for maximum valve travel, signal response, valve characteristics, inflation/deflation times etc. Data gathered will be automatically download into the embedded software to ensure optimum performance of the valve/actuator combination.

Autostroke commissioning will take approximately 1 to 3 minutes to complete depending on air pressure and actuator size etc.

Autostroke commissioning must be carried out on start-up or at any other time if the valve performance is not satisfactory.

9.4.1 TRAVL - % travel display

Programming notes

Press **C** key to access **TRAVL**.

Provides selection of % valve travel display with option of 0 - 100% or 100 - 0%.

Default is 0 - 100%.

Use **▲** and **▼** keys to toggle selection.

Press **C** key to return to **AUTOS**.

Commissioning notes

The selection of % valve travel display depends on the valve and actuator configuration. Figures 33 to 36 (pages 35 and 36), and Figures 37 and 38 (page 37) provide guidance on selection. After completion of **AUTOS** if a change is made to **TRAVL** it will be necessary to initiate an **AUTOS** routine once again.

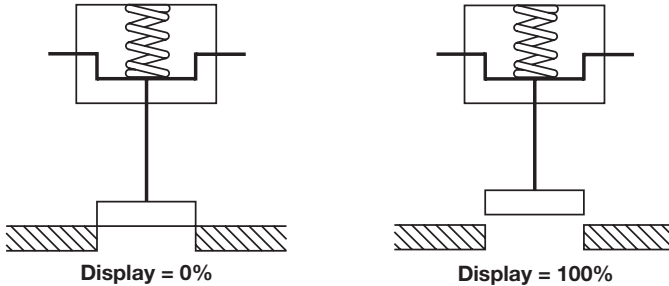

Fig. 33 2-port valve normally closed - TRAVL setting = 0 to 100%

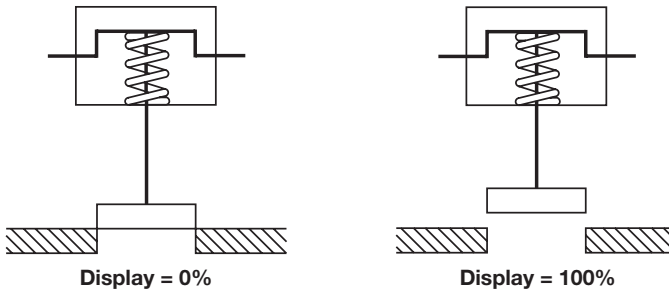
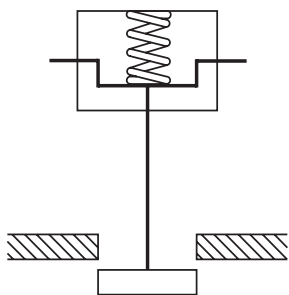
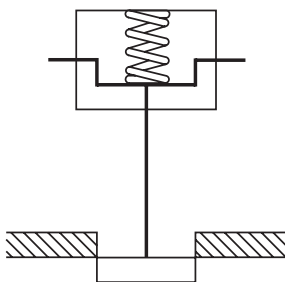

Fig. 34 2-port valve normally open - TRAVL setting = 0 to 100%



Display = 100%



Display = 0%

Fig. 35 2-port valve normally open - TRAVL setting = 100% to 0%

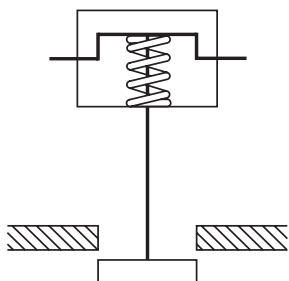

Display = 100%

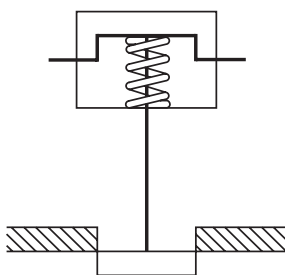

Display = 0%

Fig. 36 2-port valve normally closed - TRAVL setting = 100% to 0%

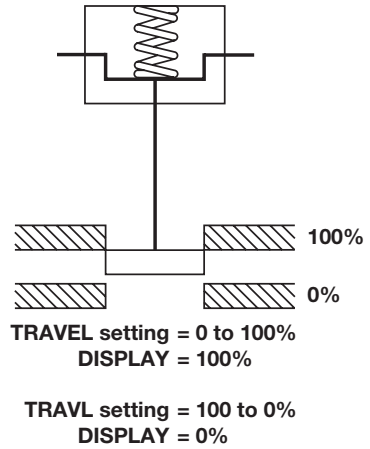
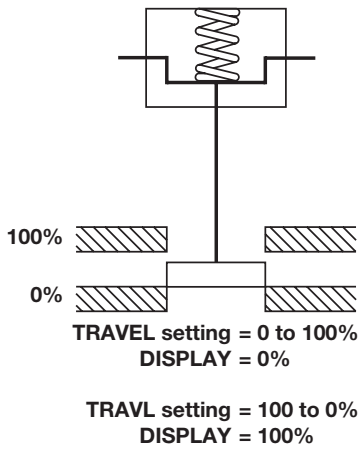

Fig. 37 3-port valve and spring extend actuator

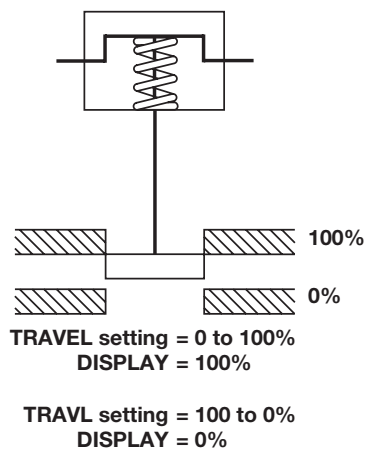
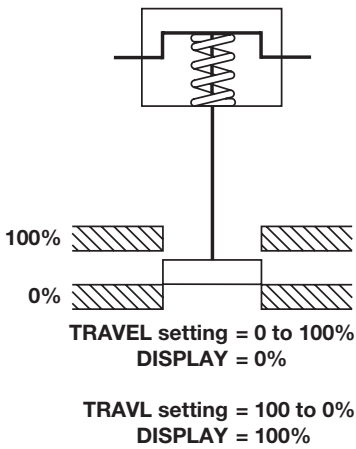

Fig. 38 3-port valve and spring retract actuator

9.5 SET - setting of valve functions

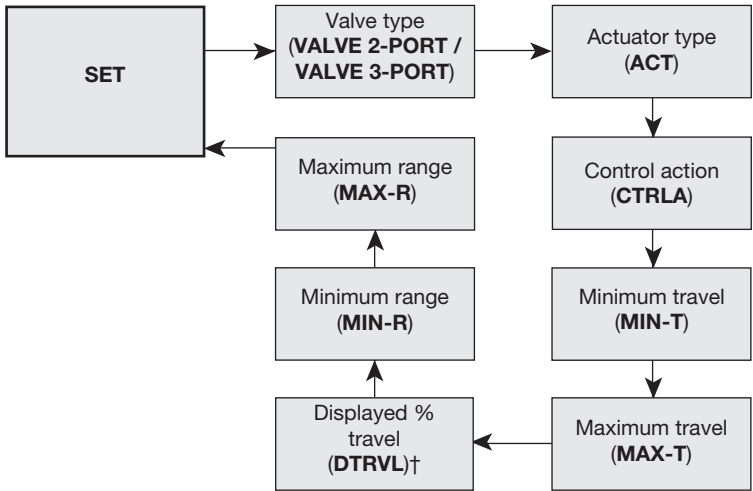

Fig. 39

† Only if MIN-T / MAX-T not 0 / 100%

Programming notes

Provides access to basic valve set up functions. Press **C** key to scroll round all **SET** functions.

Functions include:

- | | | |
|--------------------------|---------------------|----------------|
| - Valve type | (2-port or 3-port) | (VALVE) |
| - Actuator type | (on/off) | (ACT) |
| - Control action | (direct or reverse) | (CTRLA) |
| - Minimum travel setting | (0 to 66.66%) | (MIN-T) |
| - Maximum travel setting | (33.3 to 100%) | (MAX-T) |
| - Displayed % travel | (on/off) | (DTRVL) |
| - Minimum span range | (input mA signal) | (MIN-R) |
| - Maximum span range | (input mA signal) | (MAX-R) |

Press **C** key to advance to valve type **(VALVE)**. Repeat pressing of **C** key will scroll round all **SET** functions.

Press **▼** key to advance to **TUNE** in the main menu.

Commissioning notes

Each **SET** function has a default value as listed in the Installation and Maintenance Instructions. Default values are based on a 2-port normally closed valve having maximum 95% lift and an input signal span range 4 - 20 mA.

SET values should be adjusted to suit the valve type (2-port or 3-port) and application. Functions include the facility to change the control action, limit the full travel of the valve plug (minimum and maximum) and to split range the input signal.

More detailed information is provided for each **SET** function.

9.5.1 VALVE - valve type

Programming notes

Provides selection between 2-port and 3-port valves. Default is 2-port valve. Default values for travel limit settings (**MIN-T** and **MAX-T**) and early vent / inflate settings (**S-MIN** and **S-MAX**) will depend on the valve type (2-port or 3-port) and control action (direct or reverse) as follows:

Valve type	2-port		3-port	
	Direct	Reverse	Direct	Reverse
MIN-T	0%	0%	0%	0%
MAX-T	95%	95%	100	100%
S-MIN	0.1%	OFF	0.1%	0.1%
S-MAX	OFF	0.1%	0.1%	0.1%

Use ▲ and ▼ keys to select type. Press C key to accept displayed type and advance to actuator type (**ACT**).

Commissioning notes

Selection of 2-port or 3-port valves will automatically alter the maximum travel default value (**MAX-T**) to 95% for 2-port and 100% for 3-port valves. Advance to **MAX-T** to change these values if required.

9.5.2 ACT - actuator type

Programming notes

ACT selection is useful to avoid hunting using small actuators like PN5100, PN6100, PN9100 or PN9200 series. Selection is 'ON' or 'OFF'. Default value is 'OFF'.

Use the ▲ and ▼ keys to toggle selection. Press C key to accept displayed value and advance to Control action (**CTRLA**).

Selection options:

'OFF' Any pneumatic actuator except when hunting is evident.

'ON' Any small actuator like PN5100, PN6100, PN9100 or PN9200.

Commissioning notes

Selection of 'ON' automatically adjusts certain programming values to obtain optimum performance for small actuator like type PN5100, PN6100, PN9100 or PN9200 series.

ACT doesn't modify parameters set by other functions of the programming menu.

When **ACT** is **ON** there could be a light speed slow down approaching to the target position.

This behaviour doesn't influence SP200 performance and guarantee a positioning without hunting.

If a residual hunting or oscillation is present it is possible to operate changing Deadband (**dBAND**), Valve opening time (**T-UP**), Valve closing time (**T-DWN**).

If **ACT** is 'OFF' standard control values found during Autostroke will be used.

9.5.3 CTRLA - direct or reverse control action

Programming notes

Provides selection of direct (**DIRCT**) (4 - 20 mA) or reversed (**REV**) (20 - 4 mA) valve positioning control action. Press ▲ and ▼ keys to select desired action. Default action is **DIRCT**.

Default values for travel limit settings (**MIN-T** and **MAX-T**) and early shut-off vent / inflate settings (**S-MIN** and **S-MAX**) will depend on the valve type (2-port or 3-port) and control action (direct or reverse) as follows:

DIR - direct action

Display	2-port	3-port
MIN-T	0%	0%
MAX-T	95%	100%
S-MIN	0.1%	0.1%
S-MAX	OFF	0.1%

REV - reverse action

Display	2-port	3-port
MIN-T	0%	0%
MAX-T	95%	100%
S-MIN	OFF	0.1%
S-MAX	0.1%	0.1%

Press **C** key to accept the displayed action and advance to minimum travel setting (**MIN-T**).

Commissioning notes

Selection of direct or reverse action changes the direct of valve plug movement relative to the input signal. Refer to Figures 40 and 41, and the table shown in Figure 42 for further guidance.

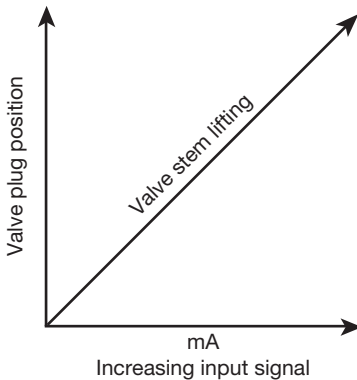

Fig. 40 Direct action (DIR)

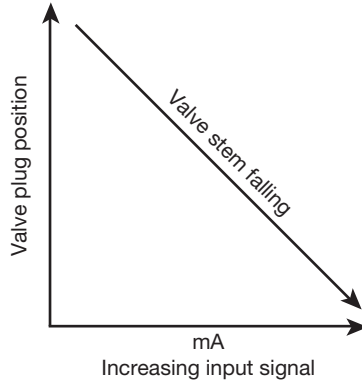
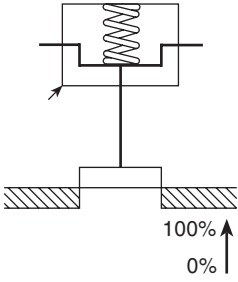
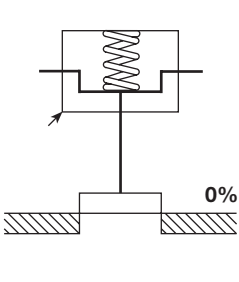
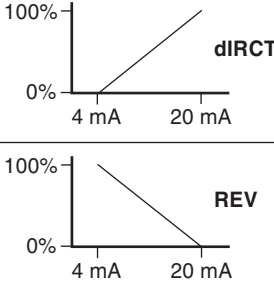
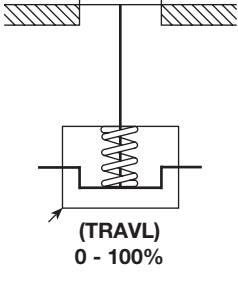
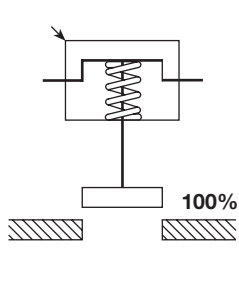
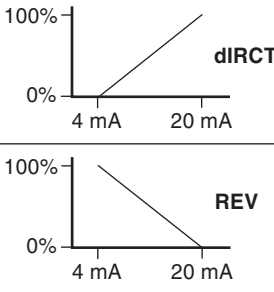
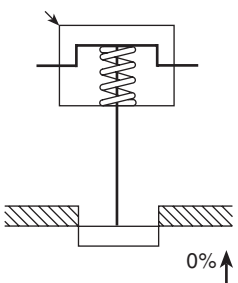
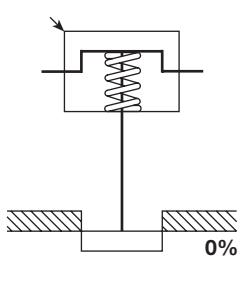
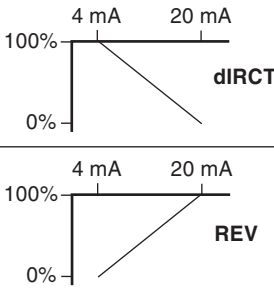
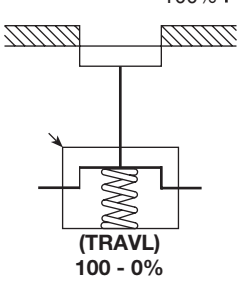
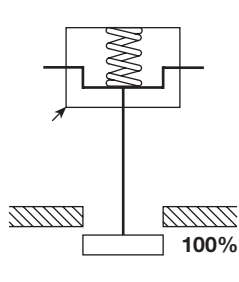
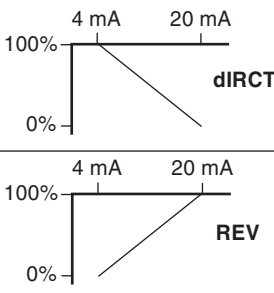

Fig. 41 Reverse action (REV)

Fig. 42 CTRL Control Action dIRECT or REV setting guidance

Installed orientation	At-rest position	Control action
		
 <p>(TRAVL) 0 - 100%</p>		
		
 <p>(TRAVL) 100 - 0%</p>		
<p>Manual Selection of required % travel (TRAVL)</p>	<p>Automatic determination Spring action only affects the rest or fail-safe position</p>	<p>Manual Selection of required Control Action (CTRLA)</p>

9.5.4 MIN-T - minimum travel setting

Programming notes

Enables the minimum valve travel to be set as a percentage of the maximum travel obtained during autostroke. Maximum setting is **MAX-T** less 33.3%. Default value is 0%.

Use ▲ and ▼ keys to alter the displayed value. Press C key to accept the displayed value and advance to the maximum travel setting (**MAX-T**).

Commissioning notes

Minimum travel should be used where a minimum flowrate is required to be maintained through the valve, (i.e. a cooling water application). Setting a minimum travel % value will prevent the valve fully closing.

The input signal span range set (**MIN-R**) and (**MAX-R**) will operate over the travel limits set. If a value for **MIN-T** is set it will exclude the setting of shut-off minimum (**S-MIN**) for control action direct (**DIR**) and shut-off maximum (**S-MAX**) for control action reverse (**REV**).

9.5.5 MAX-T - maximum travel setting

Programming notes

Enables the maximum valve travel to be set as a percentage of the maximum travel measured during autostroke. Minimum setting is **MIN-T** plus 33.3%.

Default values will depend on the selection of valve type (2-port or 3-port) and control action (direct or reverse) as follows:

Valve type	Direct	Reverse
2-port	95%	95%
3-port	100%	100%

Use ▲ and ▼ keys to adjust the displayed value. Press C key to accept displayed value and advance to the next function.

Commissioning notes

The maximum valve travel percentage should be used to prevent a control valve fully opening. This is useful for applications where the valve is oversized or to restrict the maximum flowrate through the valve.

On 2-port valves the default value is 95% to prevent the back of the plug hitting the bonnet. On 3-port valves to ensure shut-off on both seats a 100% setting is required.

The input signal span range set (**MIN-R**) and (**MAX-R**) will operate over the travel limits set. If a value for **MAX-T** is set it will exclude the setting of shut-off maximum (**S-MAX**) for direct action (**DIR**) and shut-off minimum control action (**S-MIN**) for reverse action (**REV**).

9.5.6 DTRVL - displayed travel percentage

Programming notes

The full mechanical limits of valve travel (0 to 100%) are measured during autostroke (**AUTOS**).

It is possible to limit the minimum and maximum valve travel by programming **MIN-T** and **MAX-T** values, i.e. **MAX-T** maximum travel limit of 95% (Autostroke default value for 2-port valves).

DTRVL (0 to 100% displayed travel value) can be displayed over the actual mechanical travel limits (as measured during Autostroke), or adjusted **MIN-T** and **MAX-T** travel settings.

DTRVL programming options

DTRVL - ON will display 0 to 100% over the **MIN-T** and **MAX-T** travel settings, or,

DTRVL - OFF will display 0 to 100% over the actual mechanical limits of travel.

Default value is **DTRVL - ON**. Use ▲ and ▼ keys to toggle selection.

Press C key to accept displayed 'ON' or 'OFF' option and advance to minimum range setting (**MIN-R**).

Examples

Example 1

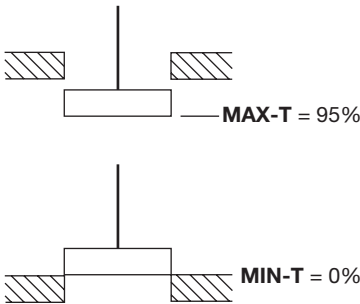

Display values	
DTRVL - ON	DTRVL - OFF
100%	95%
0%	0%

Example 2

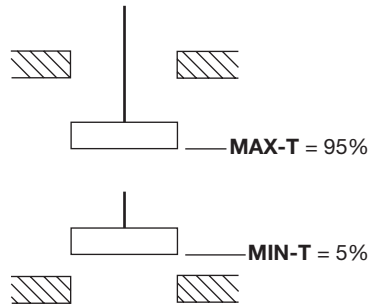

Display values	
DTRVL - ON	DTRVL - OFF
100%	95%
0%	5%

Commissioning notes

DTRVL provides the choice of travel display. For 2-port valves you can adjust the **MAX-T** setting to achieve the actual desired valve lift (i.e. 20 mm or 30 mm, etc). Using **DTRVL** you can then choose to display the **MAX-T** valve travel you have set as 100%.

9.5.7 MIN-R - minimum signal span range

Programming notes

Enables the minimum mA input signal span range to be set. The value set will correspond to the minimum travel setting. Default value is 4 mA.

Use ▲ and ▼ keys to alter the displayed value. Minimum difference between **MIN-R** and **MAX-R** is 4 mA.

Press C key to accept the displayed value and advance to the maximum mA input span range (**MAX-R**).

Commissioning notes

This function can be used to set split range applications i.e. 4 - 12 mA or 12 - 20 mA. To ensure tight shut-off refer to Section 9.6.2 **S-MIN**, page 46.

9.5.8 MAX-R - maximum signal span range

Programming notes

Enables the maximum mA input signal span range to be set. The value set will correspond to the maximum travel setting. Default value is 20 mA.

Use ▲ and ▼ keys to alter the displayed value. Minimum difference between **MIN-R** and **MAX-R** is 4 mA.

Press C key to accept the displayed value and return to **SET** in the main menu.

Commissioning notes

This function can be used to easily set split range applications i.e. 4 - 12 mA or 12 - 20 mA. To ensure tight shut-off refer to Section 9.6.3 **S-MAX**, page 47.

9.6 TUNE - setting of valve tune functions

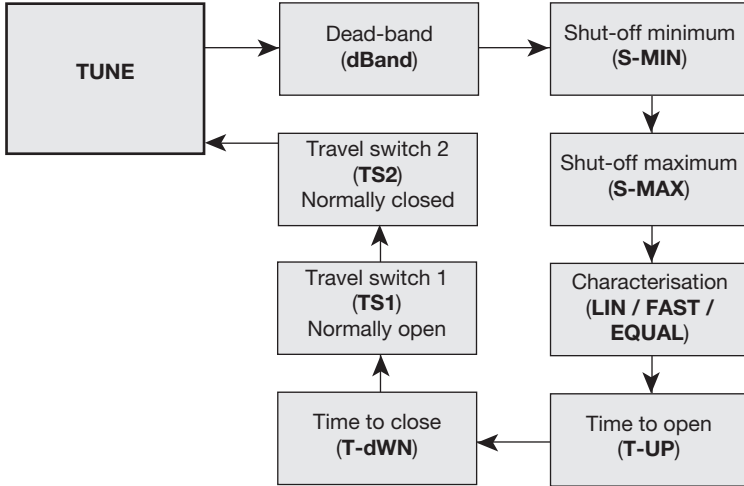

Fig. 42

Provides access to more advanced valve tuning functions including:

- Dead-band (valve positioning sensitivity) **(dBAND)**
- Shut-off minimum (ensures tight closure) **(S-MIN)**
- Shut-off maximum (ensures tight closure) **(S-MAX)**
- Characterisation (signal / lift relationship) **(CHAR)**
- Time open (slows down valve opening) **(T-UP)**
- Time close (slows down valve closure) **(T-dWN)**
- Travel switch 1 normally open (sets software travel switch) **(TS1)**
- Travel switch 2 normally closed (sets software travel switch) **(TS2)**

Programming notes

Press **C** key to advance to deadband **(dBAND)**. Repeated pressing of **C** key will scroll round all TUNE functions. **If you do not wish to alter TUNE default values** press **▼** key to advance to **RUN** in the main menu.

Commissioning notes

Each **TUNE** function has a default value as listed in the Installation and Maintenance Instructions. Default values are based on a 2-port normally closed valve having maximum 95% lift and an input signal span range 4 - 20 mA.

TUNE values should be adjusted to suit the valve type and application. Functions include:

1. The facility to alter deadband positioning sensitivity (to dampen out signal fluctuations).
2. Setting input signal to achieve tight shut-off (inflation and deflation of actuator).
3. Relationship between valve lift to input signal.
4. Slowing down the valve open or closing time duration.
5. Setting the switching position for the software travel switches.

More detailed information is provided for each **TUNE** function.

9.6.1 dbANd - deadband setting (positional sensitivity)

Programming notes

Dead-band provides adjustment of the valve positioning sensitivity relative to the input signal and is expressed as a % of the input signal span.

Default value based on a 4 - 20 mA input signal span is 0.5% with a minimum setting of 0.2%. **Note:** 3% may be displayed if **ACT** is set to **'ON'**. Refer to Section 9.5.2, page 39.

These values may change if the input signal span is reduced i.e. for a 4 mA input signal span the default and minimum setting is 0.8%.

The maximum setting is 10% of the input signal span.

To alter the displayed value press ▲ and ▼ keys. Press C key to accept the displayed value and advance to the shut-off minimum (**S-MIN**).

Commissioning notes

Setting a narrow deadband may induce oscillations of valve movement caused by fluctuations in the input signal, high stem friction or operating at low ambient temperatures below 0°C. Setting a wider deadband will dampen out oscillations but may cause an inaccuracy in actual valve position. This effect will increase if valve travel is limited. It is normally recommended that the default value is used. If necessary gradually increase the % value to dampen out any oscillations in valve movement. This may be necessary for valves having graphite packed stem seals or smaller size actuators where typically a deadband of 4% may be required.

9.6.2 S-MIN - valve shut-off - minimum travel

Programming notes

Provides the facility to fully vent the actuator at a predetermined input signal.

The value set is a percentage of the input signal span range, i.e. setting a value of 10% with an input span range of 4 - 20 mA (span 16 mA), will cause the valve to close with an input signal of 5.6 mA i.e. 4 mA + 1.6 mA (10% of 16 mA). Maximum setting is 20%.

Default values will depend on the selection of valve type (2-port or 3-port) and control action (direct or reverse) as follows:

Valve type	Direct	Reverse
2-port	0.1%	Off%
3-port	0.1%	0.1%

For direct control action (**DIRCT**) can only be set if **MIN-T = 0%** (will vent the actuator at set value). For reverse action (**REV**) can only be set if **MAX-T = 100%** (will inflate the actuator at set value).

Press ▲ and ▼ keys to alter the displayed value. Press C key to accept the displayed value and advance to shut-off maximum (**S-MAX**).

Commissioning notes

With an actual input signal equivalent to minimum input signal span range (**MIN-R**) it may cause the valve plug to hover over the seat preventing tight closure with the possibility of erosion damage to the plug and seat faces. Setting a shut-off value can help prevent this by providing early closure of the valve.

9.6.3 S-MAX - valve shut-off maximum

Programming notes

Provides the facility to fully inflate the actuator at a pre-determined input signal. The value set is a percentage of the input signal span range, i.e. setting a value of 10% with an input span range of 4 - 20 mA (16 mA), will cause the valve to close with an input signal of 18.4 mA i.e. 20 mA - 1.6 mA (10% of 16 mA). Maximum setting is 20%.

Default values will depend on the selection of valve type (2-port or 3-port) and control action (direct or reverse) as follows:

Valve type	Direct	Reverse
2-port	Off	0.1%
3-port	0.1%	0.1%

For direct action (**DIRCT**) can only be set if **MAX-T = 100%** (will inflate the actuator at set value). For reverse action (**REV**) can only be set if **MIN-T = 0%** (will vent the actuator at set value).

Press ▲ and ▼ keys to alter displayed value. Press C key to accept the displayed value and advance to the characterisation (**CHAR**).

Commissioning notes

With an actual input signal of 20 mA and a maximum span range setting (**MAX-R**) of 20 mA may cause the valve plug to hover over the seat preventing tight closure with the possibility of erosion damage to the plug and seat. Setting a shut-off value can help prevent this by providing early closure of the valve.

9.6.4 CHAR - valve characterisation

Programming notes

Provides selection of linear (**LIN**), equal percentage (**EQUAL**) or fast opening (**FAST**) characterisation. Characterisation is the relationship between input signal and valve lift. Default value is Linear (**LIN**).

Use ▲ and ▼ keys to select the desired action. Press C key to accept the displayed characterisation and advance to time open (**T-UP**).

Commissioning notes

The standard characterisation for 2-port and 3-port valves is linear (**LIN**). For special applications using 2-port valves an equal percentage (**EQUAL**) or fast opening (**FAST**) characteristic can be selected. With equal percentage the valve will start to open slowly and gradually accelerate opening related to input signal. With fast opening characteristic the valve will commence to open quickly and gradually slow down opening related to the input signal. This action is in addition to the valve trim flow characterisation (refer to Figure 43 for guidance).

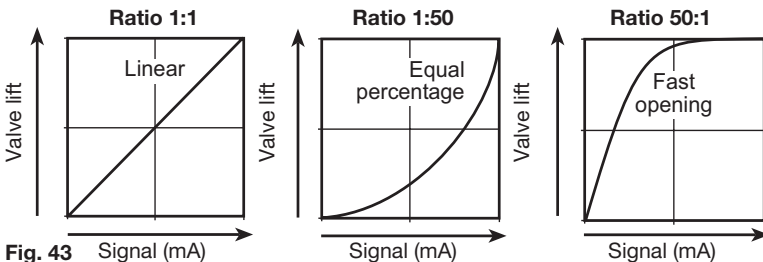

Fig. 43

9.6.5 T-UP - valve slow opening action

Programming notes

This function slows down the time taken for the valve to travel from 0 to 100% lift. The time displayed is the fastest travel time measured during autostroke (**AUTOS**). 4 seconds may be displayed if **ACT** is set to 'ON' (refer to Section 9.5.2, page 39).

Default value is the fastest time measured during autostroke.

Press ▲ and ▼ keys to alter the displayed value. Press C key to accept the displayed value and advance to time down (**T-dWN**).

Commissioning notes

The time displayed on start-up is the fastest time measured during autostroke commissioning (**AUTOS**). A time cannot be set less than the minimum recorded during autostroke. The value set will be the time taken for the valve to travel from 0 to 100% lift. The time set will apply at all times and not just at start-up. This function is useful to prevent the effects of system waterhammer, thermal shocks or slow down over-reactive systems or the effects of oversized valves. Default is the fastest time measured during autostroke. Maximum setting is 180 seconds.

9.6.6 T-dWN - valve slow closing action

Programming notes

This function slows down the time taken for the valve to travel from 100 to 0% lift. The time displayed on start-up is the fastest travel time measured during autostroke (**AUTOS**). 4 seconds may be displayed if **ACT** is set to 'ON' (refer to Section 9.5.2, page 39). Default value is the fastest time measured during autostroke.

Press ▲ and ▼ keys to alter the displayed value. Press C key to accept the displayed value and advance to travel switch 1 (**TS1**).

Commissioning notes

During autostroke routine the quickest time taken for the valve to fully close will be measured and displayed. A time cannot be set less than the minimum recorded during autostroke. The value set will be the time taken for the valve to travel from 100 to 0% lift. This action will apply at all times and not just at start-up. This function is useful to prevent the effects of system waterhammer, or to slow down over-reactive systems or the effects of oversized valves. Default is the minimum time measured during autostroke. Maximum setting is 180 seconds.

9.6.7 TS1 and TS2 software travel switches

Two switches are available **TS1** and **TS2**.

TS1 is normally open and **TS2 is normally closed**. Switching action is set as a % of valve travel (refer to Figures 44 and 45).

TS1 - software configured travel switch 1 (normally open)

Programming notes

The switching point can be set as a percentage of the valve travel between 0 to 100%. A value can be set outside the limits of the travel settings (**MIN-T**) and (**MAX-T**).

Initially **OFF** will be displayed indicating that the switch is not set. To set a switching point press **▲** and **▼** keys to alter the displayed value.

Press **C** key to accept the displayed value and advance to travel switch 2 normally closed (**TS2**).

Commissioning notes

Travel switch 1 (**TS1**) is normally open. External wiring should be made between terminals 1 (+) and 2 (-). The value set is a % of valve travel. At the set value the switch will close. The status of the switch will be shown on the LCD (refer to Figure 44).

Software configured travel switches can be used to remotely indicate valve position or to operate warning devices, fans, stirrers, motors or other process equipment via a secondary switching device.

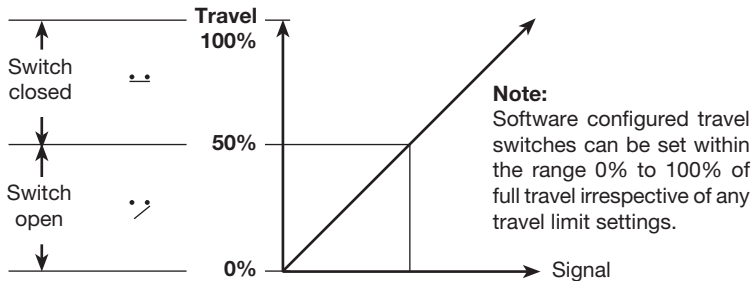

Fig. 44 TS1 Travel switch 1 (normally open)

TS2 - software configured travel switch 2 (normally closed)

Programming notes

The switching point can be set as a percentage of the valve travel between 0 to 100%. A value can be set outside the limits of the travel settings (**MIN-T**) and (**MAX-T**). Initially **OFF** will be displayed indicating that the switch is not set. To set a switching point press ▲ and ▼ keys to alter the displayed value.

Press ◁ key to accept the displayed value and return to **TUNE** in the main menu.

Commissioning notes

Travel switch 2 (**TS2**) is normally closed. External wiring should be made between terminals 3 (+) and 4 (-). The value set is a % of valve travel. At the set value the switch will open. The status of the switch will be shown on the LCD (refer to Figure 45).

Software configured travel switches can be used to remotely indicate valve position or to operate warning devices, fans, stirrers, motors or other process equipment via a secondary switching device.

Note: If the switch is in its 'off' status it will be an open circuit.

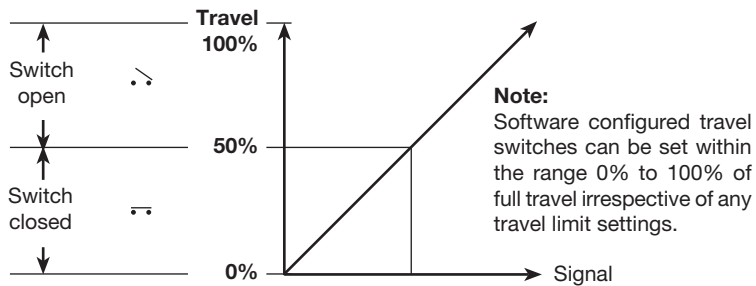

Fig. 45 TS2 Travel switch 2 (normally closed)

9.7 RUN - automatic operation

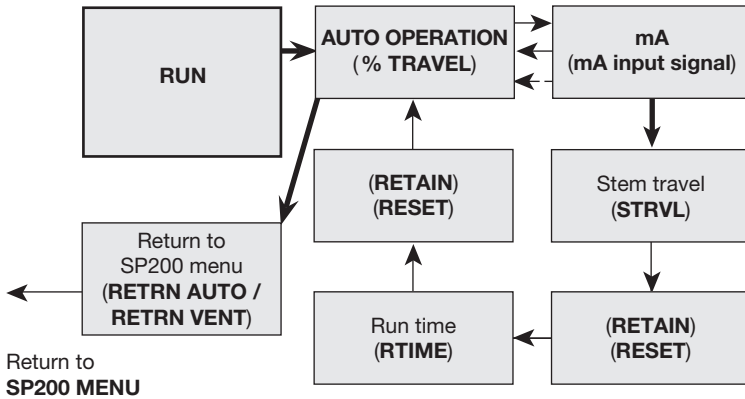

Fig. 46

Programming notes

Provides the facility to put the valve into automatic operation. Press and hold **C** key for 3 seconds to start automatic operation. The display will count down the 3 seconds.

The valve will move to a position in response to the input control signal. All values stored in the temporary memory will be transferred to the permanent memory.

Commissioning notes

By pressing and holding the **C** key for 3 seconds all values previously set will be entered into the permanent memory. The valve will move to a position as dictated by the input control signal.

To alter or check **SET** or **TUNE** values it is necessary to return to **SP200 MENU**. Press and hold **C** key for 3 seconds to return to **SP200 MENU**. The display will count down the 3 seconds.

There are two options for returning to SP200 MENU:

Option 1 is to stay in automatic control (**AUTO**) where the valve will continue to position itself relative to the input control signal.

Option 2 is to vent the actuator (**VENT**) where the valve will travel to its fail-safe position.

9.7.1 Automatic operation - % travel

Programming notes

During normal automatic operation the % valve travel will be continuously displayed together with the switch status of the software travel switches (if fitted). Additionally, a ☺ will be displayed indicating that the valve is operating satisfactorily. At any time during automatic operation the mA input signal can be displayed by pressing **C** key.

To return to **SP200 MENU** press and hold **C** key for 3 seconds. The display will count down the 3 seconds. You will advance to **RETRN** with the option of **AUTO** (automatic operation) or **VENT** (venting air from actuator). Use **▲** and **▼** keys to select the desired option. Press **C** key to accept the displayed option and return to **SP200 MENU**.

Commissioning notes

During normal operation the % valve travel will be continually displayed. A ☺ indicates that the valve is performing satisfactorily. Causes of fluctuations in valve movement can be related to input signal. Press **C** key to view actual mA input signal.

9.7.2 Input signal - mA signal display

Programming notes

The mA input signal will be displayed. Press **C** key to return to displaying % travel. The programme will automatically return to displaying % travel after 5 minutes.

It is possible to advance to view valve diagnostics data **STRVL** (total valve strokes) and **RTIME** (total run time).

To advance to **STRVL** press and hold **C** key for 3 seconds. The display will count the 3 seconds.

Commissioning notes

This function is of assistance to visualise and check input signal relative to valve position and to investigate causes of fluctuations in valve movement. The mA input signal will be displayed for 5 minutes. Press **C** key to return to displaying % travel. The programme will automatically return to displaying % travel after 5 minutes.

9.8 STRVL and RTIME - valve diagnostics

Provides visibility of total number of valve strokes (**STRVL**) and total valve run time in hours (**RTIME**).

9.8.1 STRVL - total stem travel

Programming notes

The number displayed should be multiplied by a factor of 10 to obtain the total number of complete valve strokes. A complete valve stroke is as measured in autostroke **AUTOS**.

The number displayed can be retained (**RTAIN**) or reset to zero (**RESET**). Press the **C** key to advance to **RTAIN/RESET**. Press **▲** and **▼** keys to toggle selection.

Press **C** key to accept the displayed selection and advance to run time **RTIME**.

Commissioning notes

Information displayed should be used in conjunction with total runtime **RTIME** to assess the valve usage and evaluate the need for routine maintenance, replacement of stem seals etc. The number displayed should be multiplied by a factor of 10 to obtain the local total number of complete valve strokes. (A complete valve stroke is as measured in autostroke (**AUTOS**)). The maximum possible display value is **99999**. If this value is exceeded, the display will roll over to zero and an **!** will be displayed. To retain the displayed value press the enter key and select **RTAIN**. If the valve is dismantled for maintenance inspection etc. The value can be reset if required by selecting **RESET**.

9.8.2 RTIME - total valve run time in hours

Programming notes

The number displayed is the total valve run time in hours. Run time is defined as the total time the positioner is receiving a control signal.

The number displayed can be retained (**RTAIN**) or reset to zero (**RESET**). Press the **C** key to advance to **RTAIN/RESET**. Press **▲** and **▼** keys to toggle selection. Press **C** key to accept the displayed selection and return to displaying % travel.

Commissioning notes

Information displayed should be used in conjunction with total valve strokes (**STRVL**) to assess the valve usage and evaluate the need for routine maintenance, replacement of stem seals etc. To retain the displayed value press **C** key and select **RTAIN**. If the valve is dismantled for maintenance inspection etc. The value can be reset to zero if required by selecting **RESET**.

9.9 RETRN - return to SP200 MENU in main menu

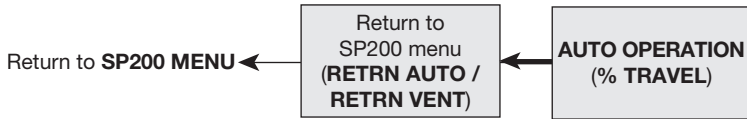

Fig. 47

Programming notes

Press and hold **C** key for 3 seconds. The display will count down the 3 seconds. This provides the facility to return to **SP200 MENU** with the option of staying in automatic operation (**AUTO**) or venting the actuator (**VENT**). Use **▲** and **▼** keys to toggle selection. Press **C** key to select and return to **SP200 MENU**.

Commissioning notes

To alter any **SET** or **TUNE** values, go into manual control (**MCTL**) it is then necessary to return to the **SP200 MENU**.

Any values altered will be recorded in the temporary memory and activated immediately. To store in the permanent memory it will be necessary to advance to **RUN** and press and hold **C** key for 3 seconds. The display will count down the 3 seconds.

To return to the main menu but stay in automatic control select **AUTO**. The valve will continue in automatic operation and respond to changes in input control signal. With the exception of **CALIB** and **MCTL** functions, main menu and subroutines will timeout after 5 minutes if no key is pressed and revert to displaying **% TRAVEL** in automatic control mode. Any temporary changes made will not be recorded in the permanent memory.

To return to main menu in a fail-safe position select **VENT**. The actuator will be fully vented of air and the valve will return to its fail-safe position.

To return to manual control (**MCTL**) advance to **MANOP** in the main menu and advance to manual control (**MCTL**). The valve can now be manually controlled using the **▲** and **▼** keys to inflate or deflate the actuator. The desired **% TRAVEL** will be displayed.

To return to automatic control advance to **RUN** and press **C** key for 3 seconds. The display will count down the 3 seconds. The valve will revert to automatic control and position itself relative to the input control signal. Any **SET** or **TUNE** values altered will be recorded in the permanent memory.

10. Maintenance

10.1 Air supply quality

As stated in Section 5.4, it is important for correct operation of the SP200 positioner that good quality air is supplied.

It is therefore recommended that a Spirax Sarco MPC2 filter regulator or equivalent is fitted on the air supply to the positioner. In addition the SP200 positioner has an internal filter. In normal operation it is recommended that this filter is replaced every 6 to 12 months depending on the air quality and valve usage. A spare filter plug kit can be obtained from Spirax Sarco that includes: filter plug, plus 3 off 'O' rings and filter.

10.2 Fitting replacement filter plug kit

To change the filter proceed as follows:

- Ensure that the air supply to the positioner is isolated.
- Unscrew the filter plug (1) from the SP200 housing using a 5 mm allen key (refer to Figure 48).

The replacement filter plug can now be fitted:

- Fit the 'O' ring (4) and filter (3) onto the filter plug (1) (refer to Figure 49).
- Finally fit the retaining screw (2).

The filter plug can now be replaced into the SP200 housing, checking that the 'O' ring (4) is correctly located.

The pneumatic air supply can now be restored to the positioner and checks made to ensure that the filter plug 'O' ring has provided the necessary air tight seal.



Fig. 48

Filter plug (1)

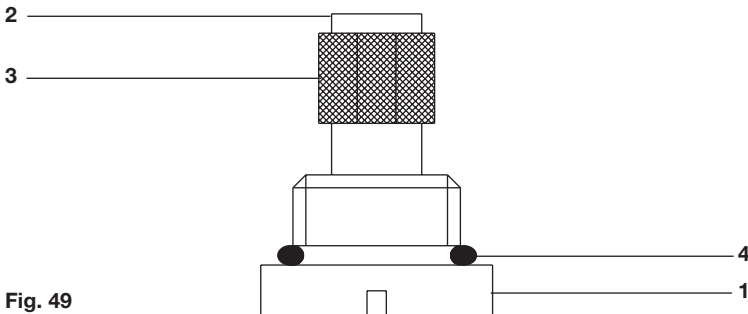

Fig. 49

11. Default values and program settings

Main menu	Sub-menu	Setting options	Default value	Programmed value
SET	Valve type (VALVE)	2-PORT 3-PORT	(2-PORT)	
SET	Actuator type (ACT)	ON OFF	OFF	
SET	Control action (CTRLA)	Direct (dIRECT) Reverse (REV)	(dIRECT)	
SET	Minimum travel (MIN-T)	0 to 66%	0%	
SET	Maximum travel (MAX-T)	33 to 100%	95% for 2-port 100% for 3-port	
SET	Displayed % travel (DTRVL)	ON OFF	ON	
SET	Minimum input signal (MIN-R)	4 to 16 mA	4 mA	
SET	Maximum input signal (MAX-R)	8 to 20 mA	20 mA	
TUNE	Dead-band (dBAND)	0.2 to 10% (% of input signal span)	0.5% (3% if ACT is ' ON ')	
TUNE	Minimum shut-off (S-MIN)	OFF , 0 to 20%	0.1%	
TUNE	Maximum shut-off (S-MAX)	OFF , 0 to 20%	OFF for 2-port 0.1% for 3-port	
TUNE	Characteristic (CHAR)	Linear (LIN), Equal (EQUAL), Fast (FAST)	(LIN)	
TUNE	Time-up (T-UP)	Autostroke time – 180 seconds	Autostroke time (seconds) 4 seconds if ACT is ' ON '	
TUNE	Time-down (T-dWN)	Autostroke time – 180 seconds	Autostroke time (seconds) 4 seconds if ACT is ' ON '	
TUNE	Travel switch 1 (TS1)	OFF , 0 to 100%	(TS1 OFF)	
TUNE	Travel switch 2 (TS2)	OFF , 0 to 100%	(TS2 OFF)	
RUN	Return to menu	Auto (RETRN AUTO) Vent (RETRN VENT)	(RETRN AUTO)	

12. Glossary of display data

12.1 Main menu display functions

Display	Description
SET UP NOW	Indicates that the SP200 positioner fitted to the valve has not been programmed or commissioned.
SP200 MENU	Indicates that you have now entered the SP200 main menu. Provides access to: <ul style="list-style-type: none"> • View the version of the embedded software. • Facility to centre the mounting position (CALIB). • Retain temporary changes to menu values (RETRN). • Recall previously stored menu values (RTAIN). • Reset to default values (RESET).
MAN OP	Provides access to manual control (MCTL) and current calibration (C-CAL).
AUTOS	Provides access to: <ul style="list-style-type: none"> • Autostroke commissioning routine. Note: SET, TUNE and RUN functions can only be accessed after a successful AUTOSTROKE routine has been completed. <ul style="list-style-type: none"> • Selection of percentage travel display % (TRAVL).
SET	Provides access to valve set up functions as follows: <ul style="list-style-type: none"> • Valve type (VALVE). • Actuator type (ACT). • Control action (CTRLA). • Minimum valve travel (MIN-T). • Maximum valve travel (MAX-T). • Displayed % travel (DTRVL). • Minimum signal range (MIN-R). • Maximum signal range (MAX-R).
TUNE	Provides access to additional valve characterisation functions as follows: <ul style="list-style-type: none"> • Dead-band sensitivity (dbAND). • Valve shut-off minimum setting (S-MIN). • Valve shut-off maximum setting (S-MAX). • Valve signal – lift characterisation (CHAR). • Valve slow opening time (T-UP). • Valve slow closing time (T-dWN). • Setting software travel switch 1 (normally open) (TS1). • Setting software travel switch 2 (normally closed) (TS2).
RUN	Provides access to: <ul style="list-style-type: none"> • Commencing automatic operation. • Displaying percentage valve travel (%). • Visualisation of input mA input signal (mA). • Total stem strokes (STRVL). • Total running time (RTIME). • Return to SP200 menu (RETRN).

12.2 Sub-menu display functions

Display	Description
VER x.xx	Indicates the version of software embedded within the SP200 positioner.
CALib	Provides facility for mounting position adjustment.
RETRN	Enables previously stored function values to be recalled.
RTAIN	Enables temporary changes made to function values to be retained.
RESET	Enables all function values to be reset to default settings. Refer to Section 11 for default settings.
MCTL	Provides manual control of the valve. Use ▲ and ▼ keys to fill or vent the actuator.
C-CAL	Calibration of the current input.
TRAVL	Selection of percentage of travel display - 0 to 100% or 100 to 0% depending on valve and actuator configuration.
AUTOS	Initiates the autostroke automatic commissioning routine.
AbORT	Indicates that the AUTOS commissioning routine has been aborted.
VALVE	Selection of 2-port or 3-port valve.
ACT	Selection for use with PN5100 or PN6100 series pneumatic actuators.
CTRLA	Selection of input signal control action 4 - 20 mA or 20 - 4 mA.
MIN-T	Setting of minimum valve travel % to prevent the valve fully closing.
MAX-T	Selection of maximum valve travel % to prevent the valve fully opening.
DTRVL	Selection of displaying 0 - 100% travel over the mechanical travel limits or adjusted MIN-T / MAX-T settings.
MIN-R	Selection of the input signal related to the minimum valve travel (MIN-T).
MAX-R	Selection of the maximum input signal related to maximum valve travel (MAX-T)
dbAND	Selection of % valve position dead-band sensitivity.
S-MIN	Facility to select pre-determined input signal to fully close the valve at the minimum travel position.
S-MAX	Facility to select a pre-determined input signal to fully close the valve at the maximum travel position.
CHAR	Selection of input signal to valve lift characterisation. Options include: <ul style="list-style-type: none"> • Linear (LIN) • Equal percentage (EQUAL) • Fast opening (FAST)
LIN	Indicates a linear relationship between the input signal and the valve travel.

Display	Description
EQUAL	Indicates an equal percentage relationship between the input signal and the valve travel.
FAST	Indicates a fast opening relationship between the input signal and the valve travel.
T-UP	Facility to slow down the valve opening movement.
T-dWN	Facility to slow down the valve closing movement.
TS1	Setting of % travel for software travel switch 1 (normally open).
TS2	Setting of % travel for software travel switch 2 (normally closed).
%	Indicates percentage of valve travel in automatic operation or manual control (MCTL).
mA	Indicates the input signal in mA.
AUTO C	Return to SP200 MENU remaining in automatic control operation.
FILL	Indicates the actuator is being filled with air (manual control before AUTOS).
☺	Indicates that there are no problems with the positioner.
!	An error or warning indication.
ERROR 1 (AUTOS)	Indicates a problem with the mounting position.
ERROR 2 (AUTOS)	Indicates that there is insufficient air pressure to position the valve.
ERROR 3 (AUTOS)	Indicates that the air cannot be vented from the actuator.
ERROR 4 (AUTOS)	Detected stroke too short.
—	Software travel switch (TS1 and TS2) - closed.
/	Software travel switch (TS1) - open.
\	Software travel switch (TS2) - open.
STRVL	Indicates the total number of valve strokes (x10). Value can be retained (RTAIN) or reset (RESET).
RTIME	Indicates the total run time of the SP200 in hours. Value can be retained (RTAIN) or reset (RESET)

13. Certification

EC-Type ATEX Certificate (Model SP200is)



Organismo autorizzato n. 0051
con D.M. 23 marzo 2004 e D.M.
2 luglio 2007



Emesso il / Issued on
Data di aggiornamento / Updated on
Sostituisce / Replaces

2008-05-08

Certificato / Certificate

[1] **Direttiva 94/9/CE** **Directive 94/9/CE**
Certificato di Esame CE del Tipo **EC-type Examination Certificate**

[2] Apparecchiature o Sistemi di Protezione destinati ad essere utilizzati in atmosfere potenzialmente esplosive - Direttiva 94/9/CE /
Equipment or Protective System intended for use in potentially explosive atmospheres - Directive 94/9/CE

[3] **Numero del Certificato di Esame CE del tipo / EC-type Examination Certificate number**

IMQ 07 ATEX 011

[4] **Apparecchiatura / Equipment**

Tipo / Type - Serie / Series

**Posizionatore elettropneumatico /
Electro-pneumatic positioner**

SP200is

[5] **Costruttore / Manufacturer**

[6] **Indirizzo / Address**

Spirax Sarco S.r.l.

**Via Per Cinisello, 18
I-20054 Nova Milanese (MI) - Italia**

[7] Questa apparecchiatura o sistema di protezione e le sue eventuali
varianti accettate sono descritti nell'allegato al presente certificato e
nei documenti descrittivi pure riportati in esso.

This equipment or protective system and any acceptable variation
thereto is specified in the schedule to this certificate and the
documents therein referred to.

[8] IMQ, organismo notificato n. 0051, in conformità all'articolo 9
della Direttiva 94/9/CE del Consiglio dell'Unione Europea del 23
Marzo 1994, certifica che questa apparecchiatura o sistema di
protezione è conforme ai requisiti essenziali di sicurezza e salute
per il progetto e la costruzione di apparecchiature e sistemi di
protezione destinati ad essere utilizzati in atmosfere
potenzialmente esplosive, definiti nell'Allegato II della Direttiva.
Le verifiche ed i risultati di prova sono registrati nel rapporto a
carattere riservato n.

IMQ, notified body n. 0051, in accordance with Article 9 of the Council
Directive 94/9/CE of 23 March 1994, certifies that this equipment or
protective system has been found to comply with the Essential Health
and Safety Requirements relating to the design and construction of
equipment and protective systems intended for use in potentially
explosive atmospheres given in Annex II to the Directive.
The examination and test results are recorded
in confidential report no.

43AG00009

[9] La conformità ai Requisiti Essenziali di Sicurezza e Salute è assicurata dalla conformità alle: /
Compliance with Essential Health and Safety Requirements has been assured by compliance with:

EN 60079-0:2006; EN 60079-11:2007; EN 61241-0:2006; EN 61241-11:2006

[10] Il simbolo "X" posto dopo il numero del certificato indica che l'apparecchiatura o il sistema di protezione è soggetto a condizioni speciali per
un utilizzo sicuro, specificate nell'allegato al presente certificato. / If the sign "X" is placed after the certificate number, it indicates that the
equipment or protective system is subject to special conditions for safe use specified in the schedule to this certificate.

[11] Questo CERTIFICATO DI ESAME CE DEL TIPO è relativo soltanto al progetto, all'esame ed alle prove dell'apparecchiatura o sistema di
protezione specificato in accordo con la Direttiva 94/9/CE. Ulteriori requisiti di questa Direttiva si applicano al processo di produzione e
fornitura dell'apparecchiatura o sistema di protezione. Questi requisiti non sono oggetto del presente certificato. /
This EC-TYPE EXAMINATION CERTIFICATE relates only to the design, examination and tests of the specified equipment or protective
system in accordance to the Directive 94/9/CE. Further requirements of the Directive apply to the manufacturing process and supply of this
equipment or protective system. These are not covered by this certificate.

[12] L'apparecchiatura o il sistema di protezione deve includere i seguenti contrassegni /
The marking of the equipment or protective system shall include the following

Ex II 2GD

**Ex ia IIC T6, T5, T4
Ex iaD 21 T85°C, T100°C, T135°C**



IMQ S.p.A. - Via Quintilano, 43 - 20130 Milano

Questo certificato, allegato incluso, può essere riprodotto solo integralmente e senza alcuna variazione. /
This certificate may only be reproduced in its entirety and without any change, schedule included.

Mod. 1073/0

EC Declaration of conformity (Model SP200is)

Spirax-Sarco s.r.l.

"Soggetta alla direzione e coordinamento di
Spirax-Sarco Engineering Plc."

Capitale Sociale Euro 2.582.300 i.v.

Sede e Stabilimento

Via per Cinisello, 18 – 20054 NOVA MILANESE - MI

Tel: 0362 – 49 17. 1 – Fax: 0362 - 49 17.310

DICHIARAZIONE CE DI CONFORMITA' EC DECLARATION OF CONFORMITY

Spirax-Sarco S.r.l. Via per Cinisello 18
20054 Nova Milanese (Mi) Italia,
Con la presente dichiara che il prodotto:
Hereby declares that this product:

POSIZIONATORE ELETTRO-PNEUMATICO TIPO SP200is

SP200is POSITIONER

Il posizionatore è destinato ad essere impiegato in atmosfere potenzialmente esplosive
The positioner is designed for use in potentially explosive atmospheres

II 2 GD Ex ia IIC T6 / Ex iaD 21 T85°C

è stato progettato, costruito ed ispezionato secondo le seguenti normative:
is designed, made and approved in accordance with the following standards:

EN 60079-0, EN 60079-11, EN 61241-0, EN 61241-11

che ottemperano ai requisiti richiesti dalla
which comply with the requisites stipulated by

Direttive Europee *European Directives:*

94/9/CE (Atex)

89/336/CEE, 92/31/CEE, 93/68/CEE (Compatibilità elettromagnetica) (*Electromagnetic Compatibility*)

NB (Ente notificato) NB (Notified Body)	Numero dell'attestato CE del tipo EC type certificate number
IMQ Indirizzo: Via Quintiliano 43 20138 Milano N° notifica 0051	IMQ 07 ATEX 011

Lo schema sopra riportato è riferito solamente alla Direttiva 94/9/CE Atex
The table above refers only to Directive 94/9/EC Atex

Nova Milanese, 02.07.2008

Il Direttore di Stabilimento

Plant Manager
Ing. Antonio Cavadini

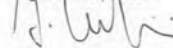

spirax/sarco

Sede legale: Via per Cinisello, 18 – 20054 Nova Milanese – MI
Iscrizione Reg. Imprese e Codice Fiscale 06527950585 – Iscrizione R.E.A. Milano 1172330 - Partita IVA 11339630151



