Scanner 2000 Steam Mass Flow Transmitter Hardware User Manual



- 1. Introduction*
 - 2. Installing the Scanner 2000*
 - 3. Wiring the Scanner 2000*
 - 4. Configuration and Operation via Keypad*
 - 5. Scanner 2000 Maintenance*
 - 6. Spare parts*
- Appendices*
- A. Scanner 2000 Hardware Options*
 - B. Lithium Battery Information*
 - C. Communications Protocol*

Important Safety Information

Symbols and Terms Used in this Manual



WARNING: This symbol identifies information about practices or circumstances that can lead to personal injury or death, property damage, or economic loss.

CAUTION: Indicates actions or procedures which if not performed correctly may lead to personal injury or incorrect function of the instrument or connected equipment.

Important: Indicates actions or procedures which may affect instrument operation or may lead to an instrument response which is not planned.

Symbols Marked on Equipment



Attention! Refer to manual



Protective (earth) ground

Technical Support Contact Information

Cameron
Measurement Systems Division
14450 John F. Kennedy Blvd.
Houston, TX 77032
Phone: 1-800-654-3760; 281-582-9500
Fax: 281-582-9599

NuFlo and ModWorX are trademarks of Cameron International Corporation (“Cameron”).
Scanner and Barton are registered trademarks of Cameron.
Modbus is a registered trademark of the Modbus Organization, Inc.
Flow-Cal is a registered trademark of Flow-Cal, Inc.
Windows is a registered trademark of Microsoft Corporation.
Acrobat Reader is a registered trademark of Adobe Systems Incorporated.

© 2010 Cameron International Corporation (“Cameron”). All information contained in this publication is confidential and proprietary property of Cameron. Any reproduction or use of these instructions, drawings, or photographs without the express written permission of an officer of Cameron is forbidden.

All Rights Reserved.
Printed in the United States of America.

Manual No. 9A-30165023, Rev. 09
March 2010

Contents

Important Safety Information	ii
Section 1—Introduction	7
Flow Rate and Fluid Property Calculations	8
Natural Gas	8
Steam.....	8
Compensated Liquid	9
Uncompensated Liquid	9
Standard Features.....	10
Product Identification	12
Hardware Options.....	13
Table 1.1—Scanner 2000 microEFM Specifications	14
Power Options.....	20
Interface Software Functions.....	21
LCD/Keypad Functions.....	22
Viewing Real-Time Measurements	23
Configuring Basic Parameters	23
Viewing Daily and Hourly Logs	24
Password-Protected Security	24
Section 2—Installing the Scanner 2000.....	25
Overview.....	25
Hazardous Area Installations	25
Pressure Safety Precautions	26
Table 2.1—MVT Pressure Limits, Approvals and Bolt Specifications	26
Wiring Considerations in Hazardous Area Installations	26
RTD Assembly Options (for Gas and Liquid Flow Runs Only).....	27
Mounting Options	27
Pole-Mount Installation	27
Measuring Natural Gas via a Differential Pressure Meter	30
Best Practices for Orifice and Cone Meter Installation	30
Installation Procedure—Direct Mount to Orifice Meter or Cone Meter.....	31
Installation Procedure—Remote Mount to Orifice Meter or Cone Meter	33
Measuring Natural Gas via a Turbine Meter.....	35
Best Practices	35
Installation Procedure—Remote Mount to a Turbine Meter.....	35
Installation Procedure—Direct Mount to a Turbine Meter (CSA Compliant)	37
Measuring Steam via a Differential Pressure Meter	39
Best Practices	39
Installation Procedure—Remote Mount to Orifice Meter or Cone Meter	40
Measuring Liquid via a Differential Pressure Meter	43
Best Practices	43
Installation Procedure—Direct Mount to Orifice Meter or Cone Meter.....	44
Installation Procedure—Remote Mount to Orifice Meter or Cone Meter	46
Measuring Compensated Liquid via a Turbine Meter	49
Best Practices	49
Installation Procedure—Direct Mount to a Turbine Meter (CSA Compliant)	49
Installation Procedure—Direct Mount to a Barton 7000 Series Turbine Meter (ATEX Compliant)	50
Measuring Uncompensated Liquid via a Turbine Meter	51
Best Practices	51
Installation Procedure—Direct Mount to a Turbine Meter (CSA Compliant)	51
Installation Procedure—Direct Mount to a Barton 7000 Series Turbine Meter (ATEX Compliant)	52

Performing a Manifold Leak Test.....	52
Zero Offset (Static Pressure or Differential Pressure).....	53
Static Pressure Calibration and Verification.....	53
Differential Pressure Calibration and Verification.....	54
Placing the Scanner into Operation.....	55
Industry Standard Compliance.....	55
Table 2.2—Industry Standards for Orifice Meters.....	56
Industry Standards for Cone Meters.....	56
Table 2.3—Industry Standards for Turbine Meters.....	57
Table 2.4—Industry Standards for Fluid Properties.....	57
Section 3—Wiring the Scanner 2000.....	59
Field Wiring Connections.....	59
Grounding Procedures.....	60
Power Supply Wiring.....	61
Internal Power Supply.....	61
External Power Supply.....	62
Input Wiring.....	63
Turbine Flowmeter Input.....	63
RTD Input.....	64
Output Wiring.....	65
Digital Output (Pulse or Alarm).....	65
RS-485 Output—Permanent Computer Connection.....	66
RS-485 Output—Laptop Computer Connection.....	67
Configuration via Keypad.....	68
Configuration via ModWorX™ Pro Software.....	68
Section 4—Configuration and Operation via Keypad.....	69
Entering the Slave Address.....	70
Entering the Baud Rate.....	71
Editing the Date and Time.....	72
Editing the Contract Hour.....	73
Editing the Plate Size.....	74
Section 5—Scanner 2000 Maintenance.....	75
Lithium Battery Pack Replacement.....	75
Circuit Assembly Replacement.....	76
Keypad Replacement.....	79
MVT Replacement.....	80
Section 6—Spare Parts.....	81
Table 6.1—Scanner 2000 microEFM Spare Parts.....	81
Table 6.2—Scanner 2000 microEFM Spare Parts (ATEX-Approved).....	83
Table 6.3—Explosion-Proof RTD and Cable Assemblies (CSA-Approved).....	84
Table 6.4—Multi-Variable Transmitters.....	84
Appendix A—Scanner 2000 Hardware Options.....	A-1
Explosion-Proof Control Switch.....	A-1
Explosion-Proof RTD Assembly.....	A-3
Communications Adapter Installation (for adapters purchased separately from a Scanner 2000).....	A-6
USB Communications Adapter.....	A-6
User-Supplied Hardware.....	A-7
Using the Adapter.....	A-7
Covering the Adapter.....	A-8
Adapter Kit Installation.....	A-8

Input/Output Expansion Board	A-8
Installation (for boards purchased separately from a Scanner 2000)	A-9
Wiring Diagrams	A-10
Measurement Canada Seal Kit.....	A-14
Seal Kit Installation	A-14
Appendix B—Lithium Battery Information.....	B-1
Lithium Battery Disposal	B-1
Transportation Information	B-1
Material Safety Data Sheet.....	B-1
Appendix C—Communications Protocol	C-1
Communications Protocol.....	C-1
Introduction.....	C-1
Supported Commands.....	C-1
Data Types	C-2
Security.....	C-3
Registers	C-3
Product Code.....	C-5
Firmware Version/Register Table Version.....	C-5
Manufacture Date/Sales Date	C-5
Analog Input 1 Calibration.....	C-16
Analog Input 2 Configuration	C-17
Analog Input 2 Calibration.....	C-17
Digital Input Configuration.....	C-18
Flow Rate Calculation Register	C-21
Fluid Property Register.....	C-22
Tap Type Register.....	C-23
Output Configuration.....	C-24
Pulse Input for Status Indication	C-25
Flow Calculation Parameter Registers (1-16).....	C-34
Base Units/Configured Units	C-34
Polling Registers.....	C-34
Interval/Daily/Event Pointer Registers	C-35
User-Defined Modbus Registers Configuration	C-43
Device Status	C-45
Enron Log Data	C-48

Section 1—Introduction

The NuFlo Scanner 2000 microEFM (Figure 1.1, page 11) packs the gas, steam, and liquid measurement capabilities commonly available only in large instruments into a compact, low-power flow computer that is rated for explosion-proof installations.

A single lithium battery pack typically powers the instrument for more than a year, making it ideal for remote locations where power supply options are limited.

The Scanner 2000 is an economical chart recorder replacement, stand-alone totalizer, and flow computer, all in one. It measures and computes standard volumes of gas, steam, petroleum liquids, and generic liquids with a high degree of accuracy. These measurements are typically based on the differential pressure outputs of an orifice plate or a cone meter, or the linear pulse output of a turbine, positive displacement or vortex flowmeter. This combination is ideal for the gas and water measurement associated with coal bed methane operations.

Combining the differential pressure and static pressure inputs of an integral MVT with a process temperature input, the Scanner 2000 offers everything needed for an AGA-3 run in a compact, explosion-proof device. Similarly, compensated liquid measurements can be obtained with an orifice meter, cone meter, or averaging pitot tube meter (such as Annubar®) installation, using flow calculations based on AGA-3, ISO-5167, or averaging pitot tube calculation methods.

Alternatively, the Scanner 2000 can be paired with a pulse output gas meter to obtain gas measurements in compliance with AGA-7 standards. Live temperature and pressure inputs and the AGA-7 algorithm allow computations based on gas turbine, rotary or vortex meters.

When liquid measurement is the goal and pressure inputs are not required, simply purchase the Scanner 2000 without the MVT and mount it directly to a liquid turbine meter, then install an RTD in the flow line for temperature compensation. The Scanner 2000 uses algorithms based on AGA-7 principles to give accurate measurement of API liquids and other generic liquids.

The addition of an optional expansion board expands the input/output capabilities to include a second turbine meter input, enabling the Scanner 2000 to measure up to three separate flow runs, which could represent a gas measurement, water measurement and oil measurement. A pulse input, two analog inputs, and an analog output are also included on the expansion board.

Every Scanner 2000 microEFM is shipped complete with software for fully configuring hardware and flow calculations, calibrating inputs, and collecting and viewing flow history. With hardware and software included in the standard product offering, the Scanner 2000 microEFM is a complete alternative to the chart recorder. Plus, because the Scanner can be powered by a lithium battery pack that is contained in the enclosure, the installation cost for a Scanner 2000 is about the same as that for a chart recorder. High-speed communication via industry standard Modbus® and Enron Modbus® protocols makes it easy to integrate the Scanner into other measurement systems.

Measurement Canada has approved the Scanner 2000's use for custody transfer applications when an optional seal kit is installed. See Appendix A—Scanner 2000 Hardware Options, for details.

For a complete list of specifications, see Table 1.1, page 14.

Flow Rate and Fluid Property Calculations

The Scanner 2000 calculates flow rates and fluid properties for natural gas, steam and liquid flow. The following descriptions identify the industry standards upon which these calculations are based.

Natural Gas

The Scanner 2000's natural gas calculations and data storage conform to AGA-3, AGA-7, AGA-8, API 21.1, and ISO-5167 industry standards. The flow calculations compensate for the effects of pressure, temperature, and gas composition to calculate the volume of gas measured at specified base conditions. These calculations typically require configuration of inputs including differential pressure, static pressure, process temperature, and for AGA-7, a turbine meter input.

The integral multi-variable transmitter (MVT) is used to measure static pressure and differential pressure. A 4-wire, 100-ohm platinum RTD is recommended for measuring process temperature. Where temperature is relatively constant, a fixed temperature value may be configured.

Orifice Plate (DP Input). The Scanner 2000 calculates natural gas flow rate from orifice plates using calculation methods found in the AGA-3 or ISO-5167 measurement standards. The natural gas fluid properties, such as density and compressibility, are calculated in accordance with AGA-8 (Detail and Gross methods). Heating values are calculated in accordance with AGA Report 3, Part 3, Appendix F using the gas properties defined in GPA 2145. Molar mass (molecular weight) calculations are also based on GPA 2145.

NuFlo Cone Meter (DP Input). The Scanner 2000 calculates natural gas flow rate from cone meters using industry-recognized algorithms identified in the NuFlo Cone Meter User Manual. The natural gas fluid properties, such as density and compressibility, are calculated in accordance with AGA-8 (Detail and Gross methods). Heating values are calculated in accordance with AGA Report 3, Part 3, Appendix F using the gas properties defined in GPA 2145. Molar mass (molecular weight) calculations are also based on GPA 2145.

Gas Turbine Meter (Frequency Input). The Scanner 2000 calculates natural gas flow rate from a gas turbine meter using calculations found in the AGA-7 measurement standard. The natural gas fluid properties, such as density and compressibility, are calculated in accordance with AGA-8 (Detail and Gross methods). Heating values are calculated in accordance with AGA Report 3, Part 3, Appendix F using the gas properties defined in GPA 2145. Molar mass (molecular weight) calculations are also based on GPA 2145.

Averaging Pitot Tube Meter (Annubar®). The Scanner 2000 calculates natural gas flow rate from an averaging pitot tube meter using calculations found in the ASME MFC-12M-2006 measurement standard. The natural gas fluid properties, such as density and compressibility, are calculated in accordance with AGA-8 (Detail and Gross methods). Heating values are calculated in accordance with AGA Report 3, Part 3, Appendix F using the gas properties defined in GPA 2145. Molar mass (molecular weight) calculations are also based on GPA 2145.

Steam

The Scanner 2000's saturated steam calculations compensate for the effects of pressure, temperature, steam properties, and steam quality.

Orifice Plate (DP Input). The Scanner 2000 supports steam measurement based on AGA-3 or ISO-5167 flow rate methods for orifice plates. Fluid properties are calculated in accordance with the IAPWS Industrial-Formulation 1997 (IF-97) standard. Temperature is calculated according to IF-97 for saturated steam, based on static pressure. Therefore, an RTD is not required. The optional Chisholm and James wet correction methods are supported for the measurement of vapor and fluid.

NuFlo Cone Meter (DP Input). The Scanner 2000 supports steam measurement using industry-recognized algorithms identified in the NuFlo Cone Meter User Manual. Fluid properties for steam are calculated in accordance with the IAPWS Industrial-Formulation 1997 (IF-97) standard. Temperature is calculated according to IF-97 for saturated steam, based on static pressure. Therefore, an RTD is not required. The optional Steven wet correction method is supported for the measurement of vapor and fluid.

Averaging Pitot Tube Meter (Annubar®). The Scanner 2000 supports steam measurement based on ASME MFC-12M -2006 flow rate methods for averaging pitot tube meters. Fluid properties are calculated in accordance with the IAPWS Industrial-Formulation 1997 (IF-97) standard. Temperature is calculated according to IF-97 for saturated steam, based on static pressure. Therefore, an RTD is not required. Wet correction methods are not supported.

Compensated Liquid

The Scanner 2000 measures compensated petroleum liquid flow using an orifice, cone, liquid turbine, or averaging pitot tube (Annubar®) flowmeter. Users can select either of two fluid property calculation methods for use with any of these flowmeters.

- The “generic” fluid properties calculation method is used to measure liquids such as water or emulsions, based on user-supplied viscosity values and either user-supplied density values or user-supplied liquid thermal expansion coefficients.
- The API-2540 calculation method provides temperature corrections for the following petroleum liquids: crude oil, gasoline, jet fuel, fuel oils, and lube oil.

Orifice Plate (DP Input). The Scanner 2000 calculates flow rates in accordance with AGA Report No. 3, Part 1 (1990) or ISO-5167 (2003) methods. When measuring liquids, the expansion factor (Y) is always equal to 1.0. Fluid property calculations for temperature-compensated measurements are based on API-2540 (1980), Petroleum Measurement Tables.

NuFlo Cone Meter (DP Input). The Scanner 2000 calculates flow rates in accordance with industry-recognized algorithms identified in the NuFlo Cone Meter User Manual. When measuring liquids, the expansion factor (Y) is always equal to 1.0. Fluid property calculations for temperature-compensated liquids are based on API-2540 (1980), Petroleum Measurement Tables.

Liquid Turbine Meter (Frequency Input). The Scanner 2000 calculates flow rates in accordance with the measurement principles upon which the AGA-7 standard is based. The user supplies a linear or multi-point calibration factor, and the instrument performs the required compensation calculations, based on the RTD input.

Averaging Pitot Tube Meter (Annubar®). The Scanner 2000 calculates flow rates in accordance with the ASME MFC-12M-2006 measurement standard. When measuring liquids, the expansion factor (Y) is always equal to 1.0. Fluid property calculations for temperature-compensated liquids are based on API-2540 (1980), Petroleum Measurement Tables.

Uncompensated Liquid

The Scanner 2000 measures uncompensated liquid flow based on the input from a liquid turbine meter or PD meter.

Liquid Turbine Meter (Frequency Input) or PD Meter (Pulse Input). The Scanner 2000 calculates flow rate from a liquid turbine meter via a frequency input, or from a contact closure (which requires the pulse input on the optional expansion board). Flow rates and totals are calculated using a user-supplied linear or multi-point calibration factor in accordance with API Manual of Petroleum Measurement Standards, Chapter 5, Section 3, Measurement of Liquid Hydrocarbons by Turbine Meters (2005).

Standard Features

The standard Scanner 2000 microEFM features an explosion-proof enclosure with two conduit openings for signal cable, a large LCD, a three-button keypad, integral multi-variable transmitter with integral vent plugs, and a lithium double-D cell battery pack (Figure 1.1, page 11). MVTs are available in NACE and non-NACE models, and with bottom ports (gas measurement) and side ports (liquid and steam measurement). For devices that are powered externally, a double-A cell battery pack is available for backup power.

Alternatively, Scanner 2000 configurations are available for direct connection to a turbine meter, which is ideal for applications that do not require pressure measurement. The CSA-approved connection is shown in Figure 1.2, page 11; the ATEX-approved connection is shown in Figure 1.3, page 12.

The main circuit board offers a turbine input, two communications ports, an RTD input, and a digital output. See Section 2—Installing the Scanner 2000, for wiring diagrams.

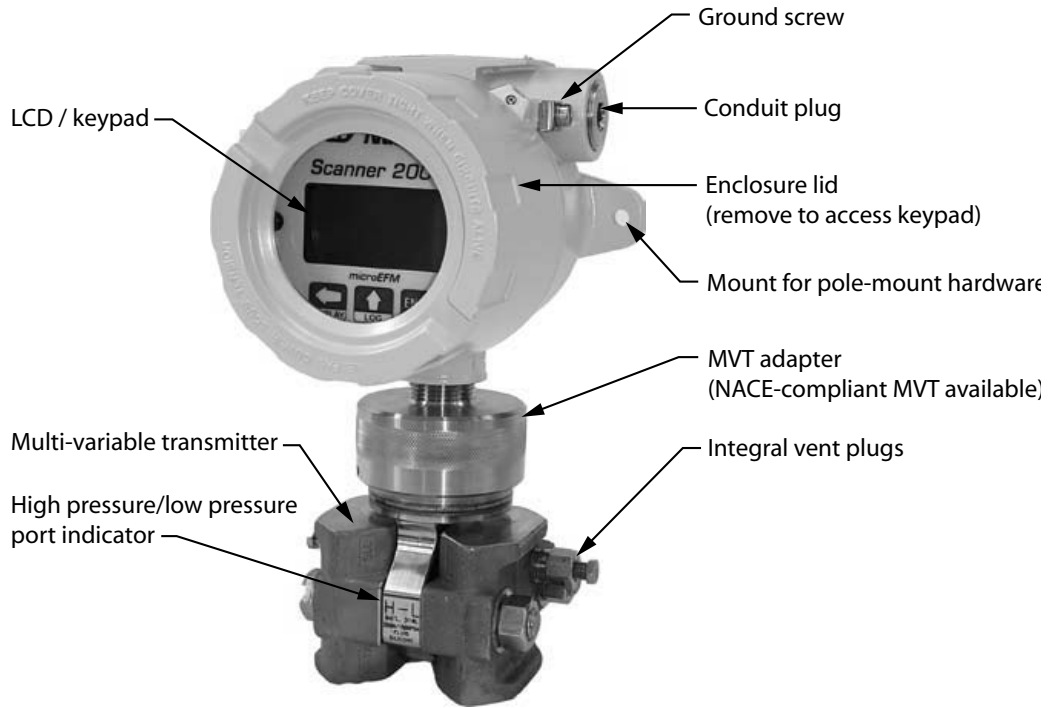

Figure 1.1—Scanner 2000 microEFM with integral MVT; MVTs are available with bottom ports (shown) or side ports

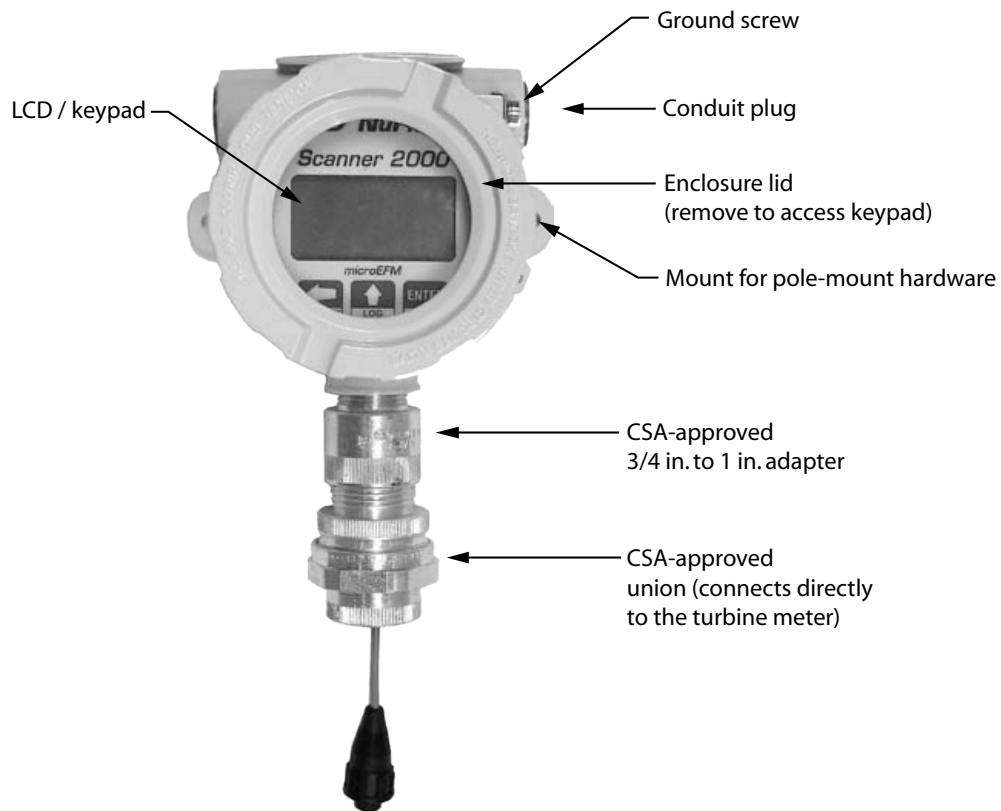

Figure 1.2—Scanner 2000 microEFM for direct connection to a turbine meter (CSA-approved)

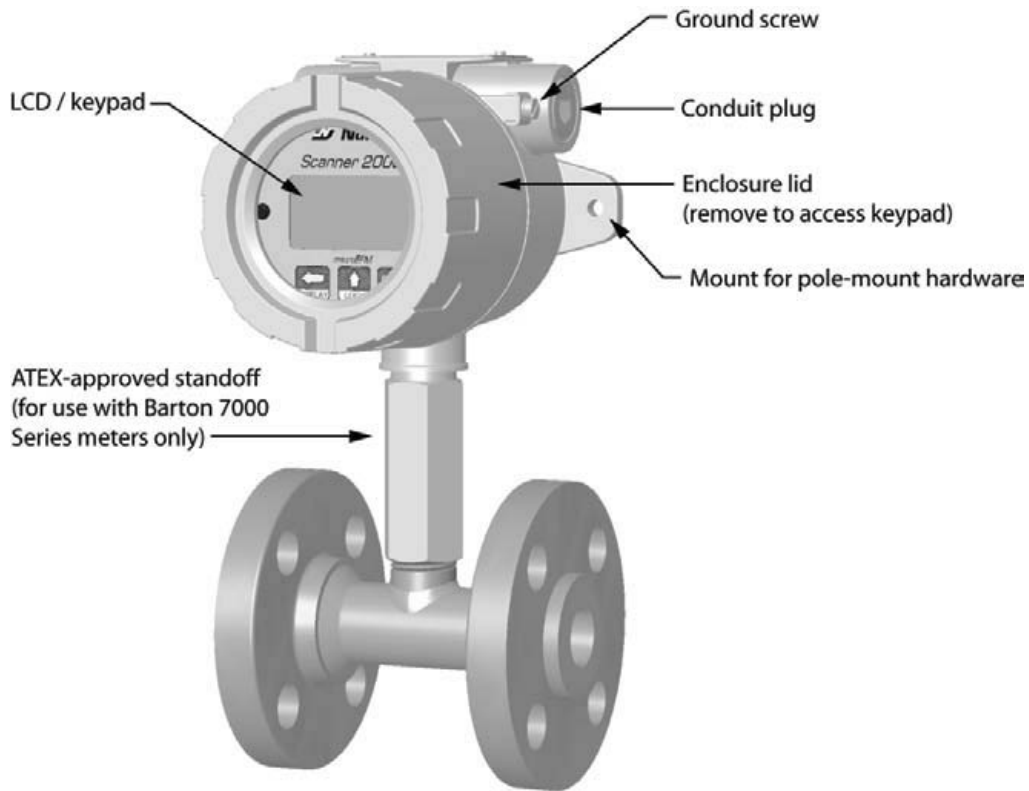

Figure 1.3—Scanner 2000 microEFM for direct connection to a Barton 7000 Series turbine meter (ATEX-approved)

Product Identification

Each device is labeled with a serial tag that identifies the product by model number and serial number and identifies the maximum operating pressure, working pressure, and differential pressure of the integral MVT (Figure 1.4). A description of the electrical protection afforded by SIRA certification and associated safety markings is also provided in Figure 1.4.

Units approved for custody transfer by Measurement Canada will have an additional label attached, bearing the MC approval number. See Measurement Canada Seal Kit, page A-14 for details.

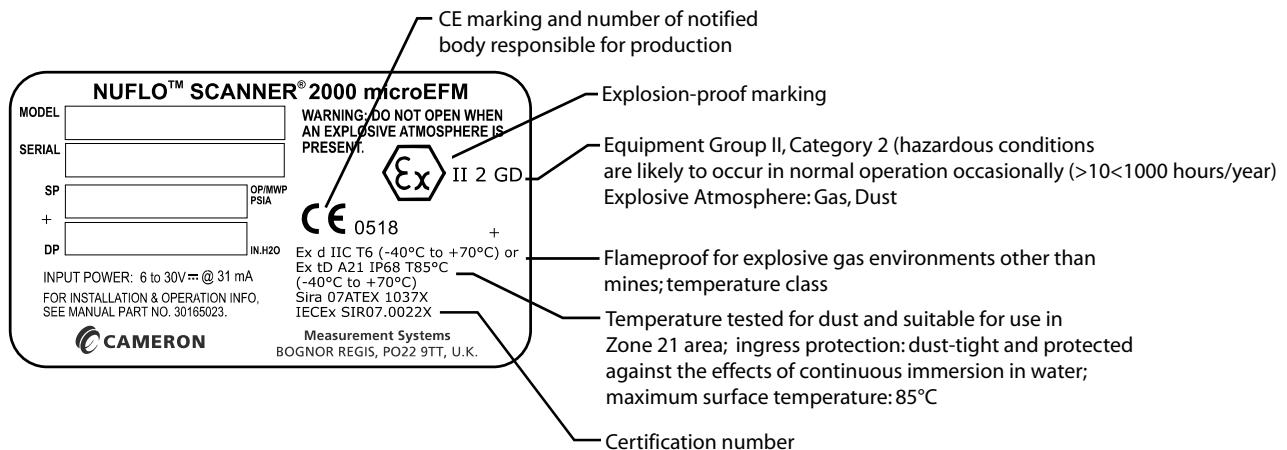

Figure 1.4—Device serial tag

Hardware Options

Several hardware options are available for customizing the Scanner 2000 to a user's specific needs.

Input/Output Expansion Board (Kit: PN 9A-30188004)

An expansion board allows the instrument to support a differential pressure meter run and two turbine meter runs simultaneously. The board features a turbine input, a pulse input, two analog inputs, an analog output, and 256 KB of memory. See Appendix A—Scanner 2000 Hardware Options for wiring diagrams.

Standard Device (Main Board Only)	Expanded Device (Main Board and Expansion Board)
Integral MVT	Integral MVT
2 RS-485 communication ports	2 RS-485 communication ports
1 process temperature input	1 process temperature input
1 turbine meter input	2 turbine meter inputs
—	1 configurable pulse input
—	2 configurable analog inputs (1-5V)
1 configurable digital output	1 configurable digital output
—	1 configurable analog output (4-20 mA)

Explosion-Proof Control Switch (CSA: PN 9A-30054001; ATEX: Part No. 9A-30054002)

During normal operation, the LCD displays the selected parameters in a continuous scroll. The explosion-proof control switch allows the user to manually control the display of parameters on the LCD and view daily logs instantaneously without removing the instrument cover. The control switch is available in both a CSA-approved model (Part No. 9A-30054001) and an ATEX-approved model (Part No. 9A-30054002). See Appendix A—Scanner 2000 Hardware Options for details.

Explosion-Proof Flexible RTD

The Barton Model 21 flexible armored RTD temperature sensor provides live temperature to the Scanner 2000. It is installed in a threaded conduit opening in the Scanner 2000 housing, and requires no conduit seals for installation. This instrument is CSA-approved for use in hazardous area installations. See Appendix A—Scanner 2000 Hardware Options for details.

Explosion-Proof Communications Adapter (CSA: PN 9A-90017004; ATEX: PN 9A-90017008)

The explosion-proof communications adapter provides a quick-connect option for communicating with the Scanner 2000 (downloading logs, for example) via laptop or PC without removing the instrument cover. Optional accessories include an RS-232 to RS-485 converter. The COM adapter is available in both a CSA-approved model (Part No. 9A-90017004) and an ATEX-approved model (Part No. 9A-90017008). See Appendix A—Scanner 2000 Hardware Options for details.

External USB Communications Adapter (CSA: 2295524-01; CSA KIT with CD: 2295634-01)

The USB communications adapter allows the connection of a Scanner 2000 directly to a USB port of a laptop or PC. A user-supplied universal USB cable is required. The adapter is factory-installed when purchased with a Scanner 2000. It is also available as a kit with an installation CD for upgrading communications in a field unit. See Appendix A—Scanner 2000 Hardware Options for details.

Pole-Mounting Kit (PN 9A-30028004)

A hardware kit consists of a mounting bracket, two U-bolts and nuts allows the Scanner 2000 to be mounted on a 2-in. pole. The mounting bracket also provides the extension necessary to keep the instrument in a vertical position when it is bulkhead-mounted to a flat, vertical surface. See Pole-Mount Installation, page 27, for details.

Scanner 1000 Series Communication and Accessory Packages

The NuFlo Scanner 1000 Series Communication and Accessory Packages provide wireless communications or telephone interface communication devices and the sub-systems to power them. Power can also be provided for control equipment such as solenoids and high-capacity relays. These packages are CSA-certified for Class I, Division 2 and NEMA 4 or 4X locations.

Measurement Canada Seal Kit

Scanner 2000 devices approved by Measurement Canada for custody transfer applications must be installed according to Measurement Canada regulations. Those regulations require the installation of a jumper and a device seal to prevent changes to the configuration of a device after the unit has been configured and the seal has been applied. An optional seal kit supplied by Cameron contains a jumper, a lead seal assembly, an Allen wrench and a label for properly marking a device. See Appendix A—Scanner 2000 Hardware Options for kit installation instructions.

Table 1.1—Scanner 2000 microEFM Specifications



Electrical Safety Classification (Standard Scanner 2000 and Scanner 2000 with Expansion Board)	Approved by CSA for US and Canada Class I, Div. 1, Groups B, C, D (explosion-proof) Type 4 enclosure, ANSI 12.27.01 single seal (0 to 3000 psi) T6 temperature class Approved by SIRA to ATEX 07ATEX 1037X IECEx SIR07.0022X  II 2 GD  Ex d IIC T6 (-40°C to +70°C) or Ex tD A21 IP68 T85°C (-40°C to +70°C) GOST-R and GOST-K certified
Pressure Classification	ASME pressure vessel code compliant, 0 to 3000 psi (CRN 0F10472.5C)
Measurement Agency Approvals	Approved by Measurement Canada for custody transfer, 0 to 1500 psi (Approval No. AG-0557C)
Enclosure	Cast aluminum, painted with epoxy and polyurethane
Weight	11.2 lb (5.08 kg), approximate
System Power	Internal power supply Battery pack, 2 “D” batteries in series, 7.2V, lithium Battery life, 1-year, typical External power supply (6 to 30 VDC) with internal battery backup (reverse polarity protected) - double A lithium battery pack is available for backup power only in externally powered devices
Operating Temperature	-40°C to 70°C (-40°F to 158°F) LCD contrast is reduced below -30°C (-22°F)
LCD Display (cont'd on next page)	8-digit top readout of values (7-segment characters) 6-digit bottom readout of scrolling parameters and associated engineering units (11-segment characters for easy-to-read prompts) View up to 12 user-defined parameters

Table 1.1—Scanner 2000 microEFM Specifications

LCD Display	View daily log data User-selectable units of measurement 0.3" character height Configurable scan parameters and duration Adjustable contrast and update period
Keypad	3-key membrane switch Password-protected security available
Logging	Daily records: 768 (>2 years) Interval records: <ul style="list-style-type: none"> • Adjustable from 5 sec to 12 hours • 2304 (>3 months of 1-hour intervals) with main board • 6392 (>8 months of 1-hour intervals) with main board and expansion board Event/alarm records: 1152 Records up to 16 user-defined parameters Logs stored in non-volatile memory for up to 10 years
Memory	Non-volatile memory for configuration and log data 256 KB standard 512 KB standard plus expansion board
Communications/ Archive Retrieval	RTU Modbus® <ul style="list-style-type: none"> • two on-board RS-485 communications ports (300 to 38.4K baud) • full download from main board in approximately 3 minutes (approx. 6 minutes with expansion board) Enron Modbus® compliant downloads User-defineable Modbus® map with up to 25 floating point values Explosion-proof control switch option <ul style="list-style-type: none"> • Alternative to keypad controls (allows navigation of LCD views without removing the enclosure lid) • View next LCD display parameter • View up to 99 daily logs on LCD Explosion-proof communications adapter option <ul style="list-style-type: none"> • External connector allows quick-connect to RS-485 COM ports without removing the enclosure lid • USB or RS-485 COM adapter installs in conduit opening
Flow Rate Calculations	Natural Gas (Orifice/NuFlo Cone): AGA Report No. 3: Orifice Metering of Natural Gas and Other Related Hydrocarbon Fluids; ISO 5167: Measurement of Fluid Flow by Means of Pressure Differential Devices Inserted in Circular Cross-Section Conduits Running Full NuFlo Cone Meter User Manual, www.c-a-m.com (Measurement Systems Division page) Natural Gas (Turbine Meter): AGA Report No. 7: Measurement of Natural Gas by Turbine Meters Natural Gas (Averaging Pitot Tube Meter): ASME MFC-12M-2006: Measurement of Fluid Flow in Closed Conduits Using Multipoint Averaging Pitot Primary Elements

Table 1.1—Scanner 2000 microEFM Specifications

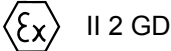
Flow Rate Calculations	<p>Steam (Orifice/NuFlo Cone): AGA Report No. 3: Orifice Metering of Natural Gas and Other Related Hydrocarbon Fluids; ISO 5167: Measurement of Fluid Flow by Means of Pressure Differential Devices Inserted in Circular Cross-Section Conduits Running Full NuFlo Cone Meter User Manual, www.c-a-m.com (Measurement Systems Division page)</p> <p>Liquids (Turbine): API Manual of Petroleum Measurement Standards, Chapter 5, Section 3, Measurement of Liquid Hydrocarbons by Turbine Meters</p> <p>Compensated Liquids (Orifice/NuFlo Cone/Turbine): AGA Report No. 3: Orifice Metering of Natural Gas and Other Related Hydrocarbon Fluids; ISO 5167: Measurement of Fluid Flow by Means of Pressure Differential Devices Inserted in Circular Cross-Section Conduits Running Full NuFlo Cone Meter User Manual, www.c-a-m.com (Measurement Systems Division page) AGA Report No. 7: Measurement of Natural Gas by Turbine Meters (as basis for liquid measurement)</p>
Fluid Property Calculations	<p>Natural Gas: AGA Report No. 8; “Compressibility Factors of Natural Gas and Other Related Hydrocarbon Gases”; Second Edition, AGA Catalogue XQ9212; American Gas Association, Arlington Virginia 1994. AGA Report No. 3, “Orifice Metering of Natural Gas and Other Hydrocarbon Fluids,” Part 3, “Natural Gas Applications,” Third Edition, 1992, Appendix F, Heating Value Calculation.” GPA 2145-09, “Table of Physical Properties for Hydrocarbons and Other Compounds of Interest to the Natural Gas Industry,” Gas Processors Association, Tulsa Oklahoma, 2008.</p> <p>Steam: IAPWS Industrial-Formulation 1997 (IF-97) Wet Correction Methods: James and Chisholm (Orifice); Steven (NuFlo Cone)</p> <p>Liquids: Generic (based on user-defined constants for density and viscosity) API-2540 - 1980, Petroleum Measurement Tables</p>
MVT	<p>Provides linearized static pressure and differential pressure Available with bottom ports or side ports NACE-compliant units also available (See Table 2.1—MVT Pressure Limits, Approvals and Bolt Specifications, page 26 for bolt specifications.) Process temperature: -40°C to 121°C (-40°F to 250°F) User-adjustable sample time and damping</p>

Table 1.1—Scanner 2000 microEFM Specifications

MVT Accuracy	Stability: Long-term drift is less than $\pm 0.05\%$ of upper range limit (URL) per year over a 5-year period Differential Pressure Accuracy (30 In. H2O) <ul style="list-style-type: none"> $\pm 0.10\%$ for spans $\geq 10\%$ of the sensor URL $\pm(0.010)$ (URL\divSPAN) for spans $< 10\%$ of the sensor URL $\pm 0.30\%$ of full scale over full operating temperature range Differential Pressure Accuracy (200 to 840 In. H2O) <ul style="list-style-type: none"> $\pm 0.05\%$ for spans $\geq 10\%$ of the sensor URL $\pm(0.005)$ (URL\divSPAN) for spans $< 10\%$ of the sensor URL $\pm 0.25\%$ of full scale over full operating temperature range 				
	Effect on differential pressure for a 100-psi change in static pressure:				
	SP/SWP (PSIA)	DP (IN H2O)	Max. Overrange (PSIA)	Zero Shift	Span Shift
	100	30	150	$\pm 0.05\%$ of URL	$\pm 0.01\%$ of reading
	300	200	450	$\pm 0.007\%$ of URL	$\pm 0.01\%$ of reading
	300	840		$\pm 0.002\%$ of URL	$\pm 0.01\%$ of reading
	500	200	750	$\pm 0.010\%$ of URL	$\pm 0.01\%$ of reading
	1500	200		$\pm 0.010\%$ of URL	$\pm 0.01\%$ of reading
	1500	300		$\pm 0.004\%$ of URL	$\pm 0.01\%$ of reading
	1500	400		$\pm 0.004\%$ of URL	$\pm 0.01\%$ of reading
	1500	840	2250	$\pm 0.004\%$ of URL	$\pm 0.01\%$ of reading
	3000*	200		$\pm 0.010\%$ of URL	$\pm 0.01\%$ of reading
	3000*	300		$\pm 0.004\%$ of URL	$\pm 0.01\%$ of reading
	3000*	400		$\pm 0.004\%$ of URL	$\pm 0.01\%$ of reading
	3000*	840	4500	$\pm 0.004\%$ of URL	$\pm 0.01\%$ of reading
	5300*	200		$\pm 0.010\%$ of URL	$\pm 0.01\%$ of reading
	5300*	300		$\pm 0.004\%$ of URL	$\pm 0.01\%$ of reading
	5300*	400		$\pm 0.004\%$ of URL	$\pm 0.01\%$ of reading
	5300*	840	7420	$\pm 0.004\%$ of URL	$\pm 0.01\%$ of reading
	5300*	200		$\pm 0.010\%$ of URL	$\pm 0.01\%$ of reading
	5300*	300		$\pm 0.004\%$ of URL	$\pm 0.01\%$ of reading
	5300*	400		$\pm 0.004\%$ of URL	$\pm 0.01\%$ of reading
	5300*	840	$\pm 0.004\%$ of URL	$\pm 0.01\%$ of reading	
* 3000-psia and 5000-psia ranges have not been evaluated by Measurement Canada					
	Static Pressure Accuracy (500 psia) <ul style="list-style-type: none"> $\pm 0.05\%$ for spans $\geq 5\%$ of the sensor URL $\pm(0.0025)$ (URL\divSPAN) for spans $< 5\%$ of the sensor URL $\pm 0.25\%$ of full scale over full operating temperature range Static Pressure Accuracy (300, 1500, 3000 and 5300 psia) <ul style="list-style-type: none"> $\pm 0.05\%$ for spans $\geq 10\%$ of the sensor URL $\pm(0.0025)$ (URL\divSPAN) for spans $< 10\%$ of the sensor URL Temperature Performance <ul style="list-style-type: none"> $\pm 0.25\%$ of full scale over full operating temperature range 				

Table 1.1—Scanner 2000 microEFM Specifications

Inputs (Main Board)	<p>Turbine Meter Input 1</p> <ul style="list-style-type: none"> Configurable sensitivity adjustment (20, 50, 100 or 200 mV, peak-to-peak) Frequency range: 0 to 3500 Hz Input amplitude: 20 mV to 3000 mV, peak to peak <table border="1"> <thead> <tr> <th rowspan="2">Turbine Setting</th> <th colspan="3">Input Sensitivity</th> </tr> <tr> <th>0 – 1000 Hz</th> <th>1000 – 2000 Hz</th> <th>2000 – 3500 Hz</th> </tr> </thead> <tbody> <tr> <td>Low (20mV)</td> <td>20 mVpp</td> <td>25 mVpp</td> <td>50 mVpp</td> </tr> <tr> <td>Med (50mV)</td> <td>50 mVpp</td> <td>70 mVpp</td> <td>110 mVpp</td> </tr> <tr> <td>High (100mV)</td> <td>100 mVpp</td> <td>150 mVpp</td> <td>250 mVpp</td> </tr> <tr> <td>Max (200mV)</td> <td>200 mVpp</td> <td>380 mVpp</td> <td>620 mVpp</td> </tr> </tbody> </table>	Turbine Setting	Input Sensitivity			0 – 1000 Hz	1000 – 2000 Hz	2000 – 3500 Hz	Low (20mV)	20 mVpp	25 mVpp	50 mVpp	Med (50mV)	50 mVpp	70 mVpp	110 mVpp	High (100mV)	100 mVpp	150 mVpp	250 mVpp	Max (200mV)	200 mVpp	380 mVpp	620 mVpp
	Turbine Setting		Input Sensitivity																					
0 – 1000 Hz		1000 – 2000 Hz	2000 – 3500 Hz																					
Low (20mV)	20 mVpp	25 mVpp	50 mVpp																					
Med (50mV)	50 mVpp	70 mVpp	110 mVpp																					
High (100mV)	100 mVpp	150 mVpp	250 mVpp																					
Max (200mV)	200 mVpp	380 mVpp	620 mVpp																					
	<p>Process Temperature Input</p> <ul style="list-style-type: none"> 100-ohm platinum RTD with 2-wire, 3-wire, or 4-wire interface Sensing Range: -40°C to 427°C (-40°F to 800°F) Accuracy: 0.2°C (0.36°F) over sensing range at calibrated temperature Temperature effect: 0.3°C over operating range of -40°C to 70°C (0.54°F over operating range of -40°F to 158°F) Resolution: 24 bits User-adjustable sample time and damping 																							
Inputs (Expansion Board)	<p>Analog Input (2)</p> <ul style="list-style-type: none"> 3-wire sensor interface Sensor power same as external power supply for main board (6 to 30 VDC) Accuracy: 0.1% of full scale Temperature effect: 0.25% of full scale over operating temperature range of -40°C to 70°C (-40°F to 158°F) Resolution: 20 bits User-adjustable sample time and damping 																							
	<p>Pulse Input</p> <ul style="list-style-type: none"> Accepts a signal from turbine meter or positive displacement meter Optically isolated Input: 3 to 30 VDC or contact closure Cannot be used as a frequency input simultaneously with Turbine Meter Input 2 Can be used as a status input when Turbine Meter Input 2 is in use 																							
	<p>Turbine Meter Input 2</p> <ul style="list-style-type: none"> Configurable sensitivity adjustment (20, 50, 100 or 200 mV, peak-to-peak) Frequency range: 0 to 3500 Hz Input amplitude: 20 mV to 3000 mV, peak to peak Cannot be used simultaneously with pulse (frequency) input <table border="1"> <thead> <tr> <th rowspan="2">Turbine Setting</th> <th colspan="3">Input Sensitivity</th> </tr> <tr> <th>0 – 1000 Hz</th> <th>1000 – 2000 Hz</th> <th>2000 – 3500 Hz</th> </tr> </thead> <tbody> <tr> <td>Low (20mV)</td> <td>20 mVpp</td> <td>25 mVpp</td> <td>50 mVpp</td> </tr> <tr> <td>Med (50mV)</td> <td>50 mVpp</td> <td>70 mVpp</td> <td>110 mVpp</td> </tr> <tr> <td>High (100mV)</td> <td>100 mVpp</td> <td>150 mVpp</td> <td>250 mVpp</td> </tr> <tr> <td>Max (200mV)</td> <td>200 mVpp</td> <td>380 mVpp</td> <td>620 mVpp</td> </tr> </tbody> </table>	Turbine Setting	Input Sensitivity			0 – 1000 Hz	1000 – 2000 Hz	2000 – 3500 Hz	Low (20mV)	20 mVpp	25 mVpp	50 mVpp	Med (50mV)	50 mVpp	70 mVpp	110 mVpp	High (100mV)	100 mVpp	150 mVpp	250 mVpp	Max (200mV)	200 mVpp	380 mVpp	620 mVpp
Turbine Setting	Input Sensitivity																							
	0 – 1000 Hz	1000 – 2000 Hz	2000 – 3500 Hz																					
Low (20mV)	20 mVpp	25 mVpp	50 mVpp																					
Med (50mV)	50 mVpp	70 mVpp	110 mVpp																					
High (100mV)	100 mVpp	150 mVpp	250 mVpp																					
Max (200mV)	200 mVpp	380 mVpp	620 mVpp																					

Table 1.1—Scanner 2000 microEFM Specifications

Output (Main Board)	<p>Digital Output</p> <ul style="list-style-type: none"> • Configurable as pulse output or alarm output • Solid-state relay • Output rating: 60 mA max @ 30 VDC <p>When configured as pulse output:</p> <ul style="list-style-type: none"> • Maximum frequency: 50 Hz • Configurable pulse duration (65,535 msec max) • Configurable pulse representation (1 pulse = 1 MCF) • Based on any accumulator (flow run or turbine meter run) <p>When configured as alarm output:</p> <ul style="list-style-type: none"> • Low/high • Out-of-range • Status/diagnostic • Latched/unlatched • Normally open/normally closed
Output (Expansion Board)	<p>Analog Output</p> <ul style="list-style-type: none"> • 4-20 mA • Accuracy: 0.1% of full scale @ 25°C (77°F), 50 PPM/°C (27.8 PPM/°F) temperature drift • Represents any measured variable (e.g., differential pressure) or calculated parameter (e.g., flow rate) • Optically isolated • Resolution: 16 bits
Interface Software	<p>Provided at no charge</p> <p>Easy to use</p> <p>Real-time data polling</p> <p>Complete configuration</p> <p>Configuration upload for configuring multiple units</p> <p>Multi-level security</p> <p>Field calibration</p> <ul style="list-style-type: none"> • 1 to 12 calibration points for each parameter • Three methods: multi-point, set zero point, and verify (API compliant) • Inputs are automatically locked during calibration <p>Maintenance</p> <ul style="list-style-type: none"> • Change plate • Change cone (linearization: 1 to 12 points) • Change gas composition • Change steam properties • Change flow coefficients • Change K-factor (linearization: 1 to 12 points) • Change turbine flowmeter • Change generic/API liquid parameters <p>Archive data downloads</p> <ul style="list-style-type: none"> • Configurable downloads of “all” or “new” records • Download types: daily, interval, and event/alarm records • Downloads are automatically saved in uneditable binary (SDF) files • Exports to .xls, .csv, .rtf, .html, and Flow-Cal® formats

Table 1.1—Scanner 2000 microEFM Specifications

Interface Software (cont'd)	Reporting <ul style="list-style-type: none"> • Daily logs (table or trend graph) • Interval logs (table or trend graph) • Event/alarm logs • Configuration settings • Calibration settings • Snapshot of current status data and calculated parameters
System Requirements	Operating System - Windows 2000 or later (Windows XP recommended) Computer/Processor - 1 GHz or faster Pentium-compatible CPU Memory - 128 MB of RAM Hard Disk Space - 100 MB for program files, 30 MB for Adobe Reader, adequate space for data files Drive - CD-ROM for install Display - 1024 x 768, 16-bit color display or greater Browser - Internet Explorer 6 or later Internet Connection - for web links, tech support Communications Port - physical or virtual RS-232 compatible serial port

Power Options

The standard Scanner 2000 microEFM can be powered two ways:

- with the internal lithium battery pack supplied with each Scanner 2000 (shown in Figure 1.5)
- with an external customer-supplied power supply (6 to 30 VDC); the lithium battery provides backup power when an external power supply is used

Wiring diagrams are provided in Section 3—Wiring the Scanner 2000.

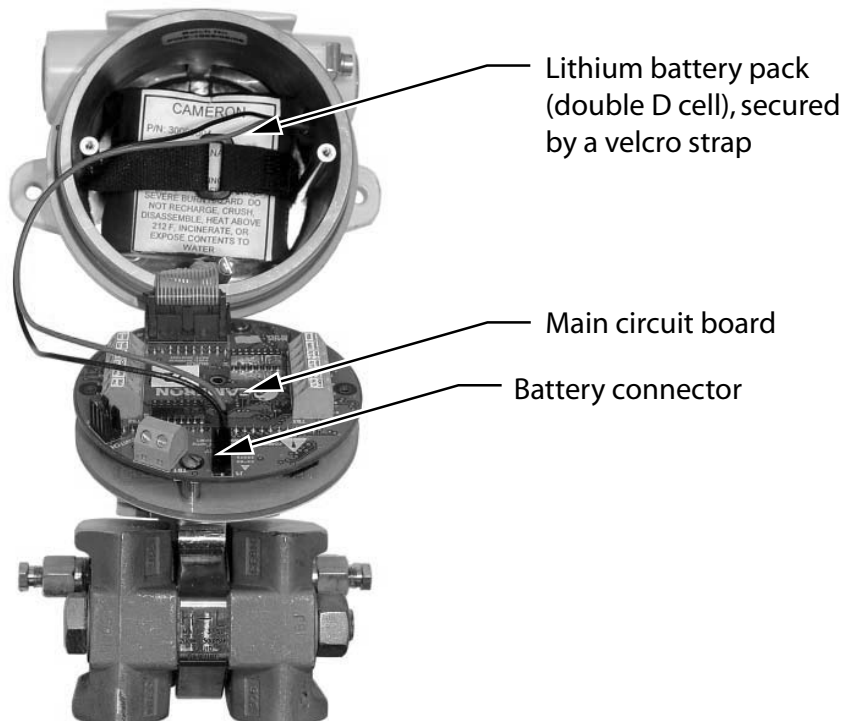

Figure 1.5— Scanner 2000 microEFM, internal view

Interface Software Functions

The ModWorX™ Pro interface software is designed for simplicity and ease of use. Its intuitive, well-organized screens allow users to calibrate and configure the Scanner 2000 microEFM within just a few minutes, and download log archives in an easy-to-read report. RTU Modbus® protocol and RS-485 communications ensure easy access to logs. Up to 16 user-selectable parameters can be logged and downloaded using ModWorX™ Pro software.

The software interface is designed around the most common needs of the field operator. A read-only Main screen (Figure 1.6) provides a quick reference to real-time totals and flow rates, input data, and system data. It is also home to four task-based menus: Calibrate, Maintain Flow Run, Maintain Turbine, or Configure, and a large red “Download” button for downloading archive data.

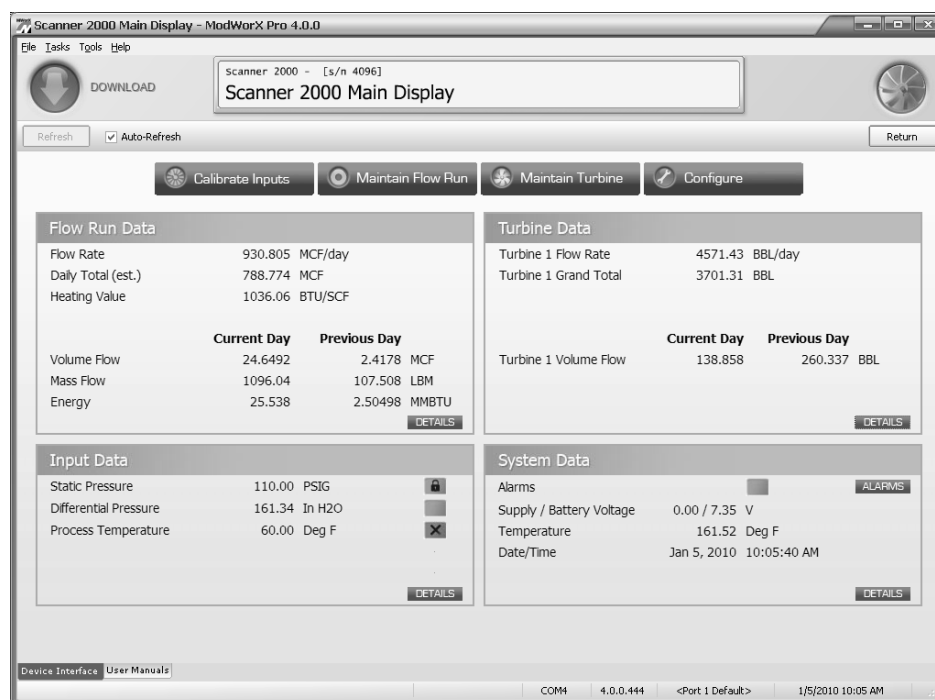

Figure 1.6—ModWorX™ Pro software interface

The standard Scanner 2000 microEFM saves up to 2304 interval logs (interval periods are adjustable from 5 sec to 12 hours), 768 daily logs, and 1152 event/alarm logs in nonvolatile memory. With the optional expansion board, the Scanner 2000 saves up to 6392 interval logs. A user can selectively download data logs and instrument configuration settings using the ModWorX™ Pro software. The download files are stored in an uneditable format on the user’s CPU, and can be viewed immediately or exported to an alternative format (.csv, .xls, .rtf, html, or Flow-Cal®).

Log data can be viewed or printed as a table or a trend chart, or exported to a spreadsheet.

Event logs track user changes to flow parameters that impact log data. Such changes may include orifice plate changes, K-factor changes, input setting changes, and device events like over-range and resets. Event/alarm logs can be viewed or printed in tabular format. In addition to showing old and new values, each event log is time-stamped, and includes the register associated with the change.

Instructions for installing the software are provided on the installation CD pocket folder provided with each instrument. User manuals containing step-by-step instructions on software functions are linked to the software interface for quick and easy access (note the tabbed links at the bottom of the screen in Figure 1.6).

LCD/Keypad Functions

From the three-button keypad on the front of the instrument, the user can perform the following tasks:

- scroll through display parameters
- view daily flow totals
- save a current total
- check the temperature and system voltage
- configure basic parameters such as slave address, baud rate, time, turbine K-factor, and orifice plate size

Section 4—Configuration and Operation via Keypad, guides users step by step through the configuration of these parameters using the keypad.

Figure 1.7 summarizes the functions that can be accessed with each button.

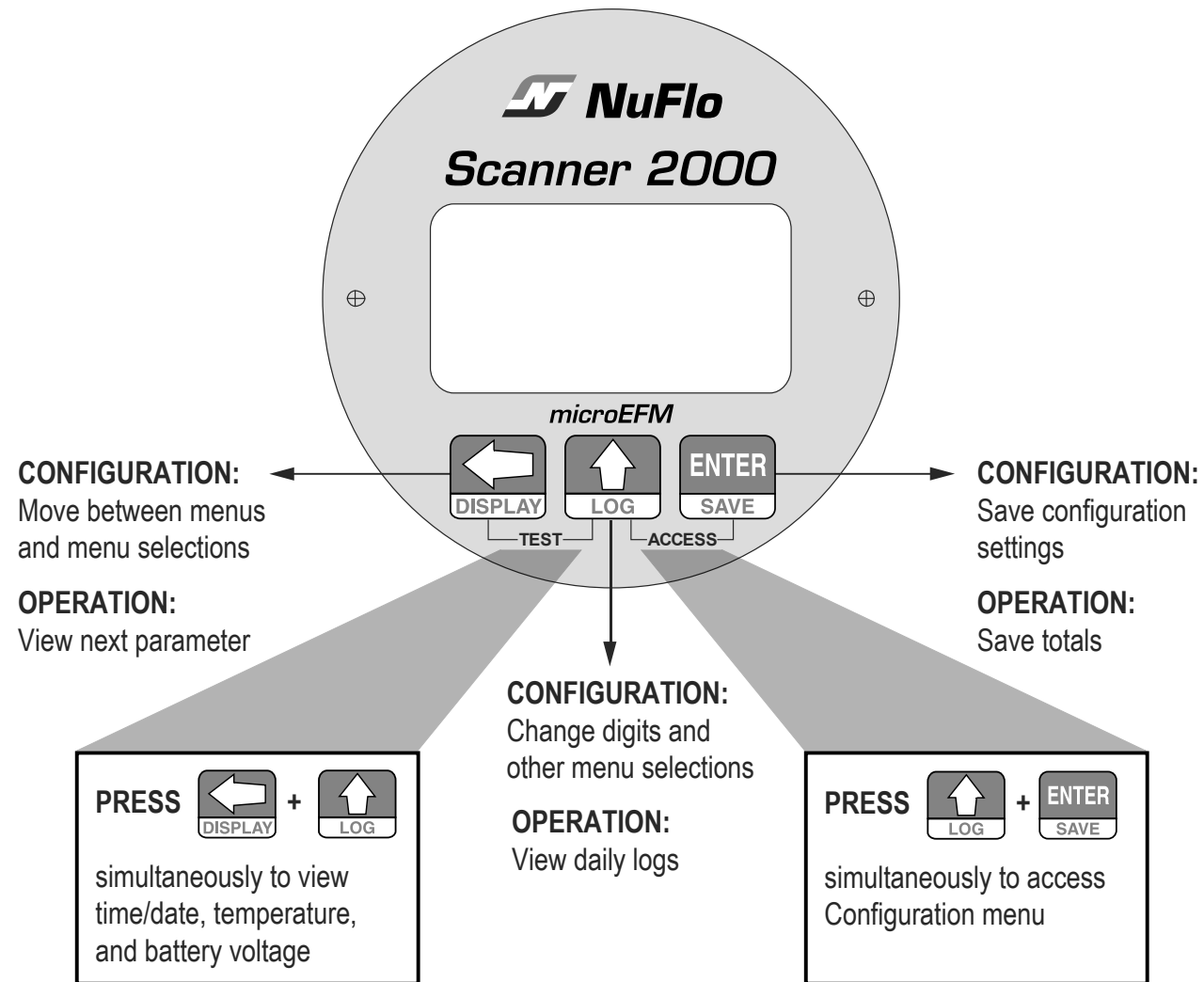

Figure 1.7—Keypad functions

Important All operating parameters can be configured using the ModWorX™ Pro software provided with the Scanner 2000. See Section 3—Wiring the Scanner 2000 for instructions on connecting your laptop or PC to the instrument.

Viewing Real-Time Measurements

Up to 12 parameters can be configured for display on the LCD using ModWorX™ Pro software. During normal operation, the LCD displays the selected parameters in a continuous scroll.

A user can stop the scrolling action and manually advance the parameter displayed on the screen by removing the cover of the instrument and pressing the LEFT ARROW button on the keypad (Figure 1.7, page 22). The parameter selected for display will appear as shown in Figure 1.8.

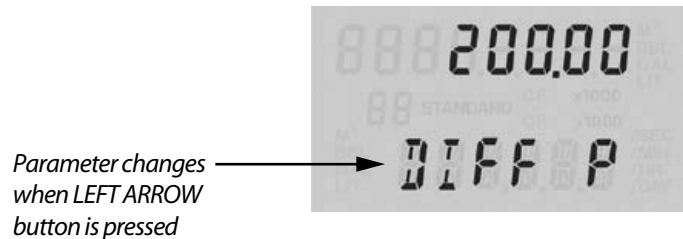

Figure 1.8—LCD display of real-time measurements

Note If the instrument is equipped with an explosion-proof switch, the user can manually control the parameter displayed without removing the instrument cover. See Appendix A—Scanner 2000 Hardware Options for more information.

Configuring Basic Parameters

Pressing the UP ARROW and ENTER buttons simultaneously allows the user to enter the configuration mode (Figure 1.9).



Figure 1.9—In configuration mode, the parameter to be configured is displayed at the bottom of the LCD and the setting for that parameter is displayed in the top LCD.

In that mode, the user can configure the following parameters without the use of a laptop computer:

- slave address
- baud rate
- date and time
- contract hour
- orifice plate size

Step-by-step instructions are provided in Section 4—Configuration and Operation via Keypad. All other instrument configuration is performed via the ModWorX™ Pro software interface.

Viewing Daily and Hourly Logs

Up to 99 consecutive daily logs can be viewed using the keypad.

Pressing the Log button changes the LCD display mode from normal operation (scrolling) to a daily log view mode (Figure 1.10). The two-digit flashing number or “log index” on the left side of the LCD represents the number of days that have passed since the log was saved. The user can increment or decrement the number by clicking the UP ARROW or DOWN ARROW buttons. For example, “01” will display the last daily log saved. An index of “05” will display the daily log saved 5 days ago.

By default, the top display shows flow volume, however the user can configure the display to show any of the 16 parameters available using ModWorX™ Pro software. The bottom display shows the date. The entire log archive—up to 768 daily logs, 2304 adjustable interval logs, and 1152 event/alarm logs— can be viewed using ModWorX™ Pro software.

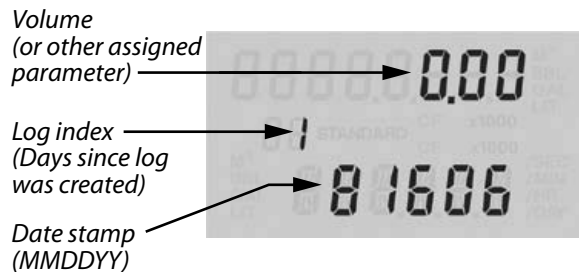

Figure 1.10—LCD display of daily logs

Password-Protected Security

A keypad security access code prevents unauthorized personnel from altering the calibration or accumulated volume data in the instrument. The security feature may be disabled if this protection is not required.

Password-protected security access is enabled using the ModWorX™ Pro software. When this feature is enabled, the user will be prompted for a four-digit password each time he attempts to enter a menu from the keypad (Figure 1.11). The ModWorX™ Pro software is required for establishing or changing the password.



Figure 1.11—LCD display of security password menu

Section 2—Installing the Scanner 2000

Overview

The Scanner 2000 microEFM is fully assembled at the time of shipment and ready for mounting. However, Cameron recommends that operators configure the microEFM prior to mounting if the instrument is to be installed in a hazardous area. The enclosure must be opened to configure the device, either via keypad controls or via software, and once the instrument is mounted in a hazardous area, the cover should not be removed unless the area is void of combustible gas and vapors.

Hazardous Area Installations

The ATEX-certified standard Scanner 2000 microEFM and the ATEX-certified Scanner 2000 microEFM with expansion board are fully compliant with European ATEX Directive 94/9/EC, Annex II, 1.0.6.

The following instructions apply to equipment covered by certificate number 07ATEX 1037X:

- The instrument may be located where flammable gases and vapours of groups IIA, IIB and IIC may be present.
- It is only certified for use in ambient temperatures in the range -40°C to $+70^{\circ}\text{C}$ and should not be used outside this range.
- It has not been assessed as a safety-related device (as referred to by Directive 94/9/EC Annex II, clause 1.5).
- Installation shall be carried out by suitably trained personnel in accordance with the applicable code of practice (EN 60079-14 within Europe).
- Repair of this equipment shall be carried out by the manufacturer or in accordance with the applicable code of practice (IEC 60079-19).
- If the instrument is likely to come into contact with aggressive substances, the user is responsible for taking suitable precautions to prevent it from being adversely affected, thus ensuring that the type of protection is not compromised.
 - Aggressive substances may include, but are not limited to, acidic liquids or gases that may attack metals, or solvents that may affect polymeric materials.
 - Suitable precautions may include, but are not limited to, regular checks as part of routine inspections or establishing from the material's data sheet that it is resistant to specific chemicals.

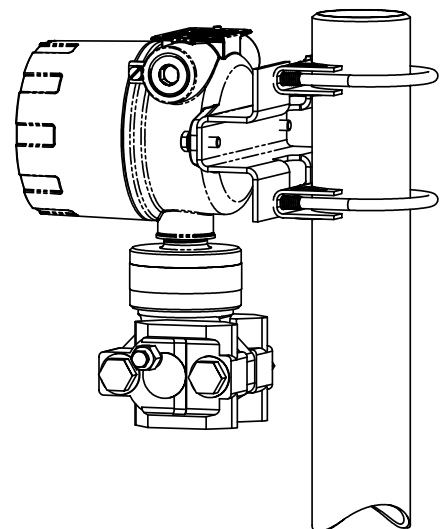

Pressure Safety Precautions



WARNING: Before connecting the Scanner 2000 microEFM to a flow line, consider the pressure rating of the sensor, and the presence of harmful gases. The tubing and fixtures used to connect the sensor to the manifold in the flow line must be manufactured from materials that are appropriate for the pressure ratings of the sensor used.



WARNING: If H₂S is present, use a NACE sensor and take appropriate precautions to avoid exposure to this hazardous gas.

Table 2.1—MVT Pressure Limits, Approvals and Bolt Specifications

SP/SWP (PSIA)	DP (IN H ₂ O)	Max. Overrange (PSIA)	Measurement Canada Approved	ASME Pressure Vessel Code Compliant	CSA Single Seal Approved	Standard Bolts	NACE Bolts
100	30	150	X	X	X	B7 or 316 SS	B7M
300	200	450	X	X	X	B7 or 316 SS	B7M
300	840						
500	200	750	X	X	X	B7 or 316 SS	B7M
1500	200	2250	X	X	X	B7 or 316 SS	B7M
1500	300						
1500	400						
1500	840						
3000	200	4500		X	X	B7 or 17-4 SS	Inconel
3000	300						
3000	400						
3000	840						
5300	200	7420				B7	Inconel
5300	300						
5300	400						
5300	840						

Wiring Considerations in Hazardous Area Installations

CAUTION For explosion-proof installations, all signal cable from other devices and power must observe local wiring practices for area classification. The cable used between the Scanner 2000 and other devices must be either armored MC-HL type cable or standard cable routed through conduit.

In accordance with EN60079-0, Clause 16.5, all cable and cable glands must be rated for 80°C.

For Zone 1 or Division 1 explosion-proof installations, conduit seals must be installed within 18 in. of the Scanner 2000.

RTD Assembly Options (for Gas and Liquid Flow Runs Only)

The RTD is installed in a thermowell downstream of the primary differential pressure source. The location of the thermowell should conform to the relative standard to ensure accurate measurement.

CAUTION The RTD must be fitted to a suitably certified and dimensioned enclosure or fitted to an enclosure in a non-hazardous area.

Cameron recommends the use of the Barton Model 21 RTD, a 4-wire, 100-ohm explosion-proof RTD assembly that can be connected to the Scanner 2000 enclosure without conduit or a conduit seal. For details, see Explosion-Proof RTD Assembly, page A-3.

A 2-wire, 3-wire, or 4-wire RTD assembly may be used to provide a process temperature input.

Mounting Options

The Scanner 2000 microEFM can be mounted using the following methods:

- Direct-mount to an orifice or cone type DP meter. The integral multi-variable sensor may be connected to the pressure taps with stabilizers or a heavy wall nipple with adapter flanges, and a 5-valve manifold. A bottom-port MVT is recommended for gas measurement; a side-mount MVT is recommended for liquid or steam measurement.
- Direct-mount to a turbine meter. The CSA-certified instrument can be mounted to a turbine meter using a pipe adapter and union connection (Figure 2.2, page 28). The ATEX-certified instrument can be mounted to a Barton 7000 Series meter using a turbine meter pickup extension (Figure 2.3, page 29).
- Pole-mount. The instrument can be mounted on a 2-in. pole using a NuFlo hardware kit, or bulkhead-mounted to a flat, vertical surface (Figure 2.4, page 29). Pole mounting may be preferred where limited space or pipe vibration prohibits direct-mount installation. A horizontal pipe mount is recommended for liquid and steam installations using a side-port MVT and block manifold. Tubing is used to connect the integral MVT to the orifice meter or cone meter. If a Scanner 2000 will be used for steam measurement, a condensate pot must also be installed to protect the Scanner 2000 from extreme temperatures. See Measuring Steam via a Differential Pressure Meter, page 39, for details.

The following accessories are also recommended:

- a 5-valve manifold for connecting process lines to the integral MVT
- an RTD assembly (see Explosion-Proof RTD Assembly, page A-3) for process temperature input on gas flow runs and compensated liquid flow runs (not recommended for steam flow runs)
- tubing and/or pipe for plumbing process connections
- explosion-proof signal cable for remote turbine connections (stranded, shielded cable is recommended)

Pole-Mount Installation

To mount the Scanner 2000 using the optional pole-mount kit, perform the following steps:

1. Determine the pipe orientation (horizontal or vertical) that will best accommodate process connections and field wiring connections. A horizontal pipe mount is recommended for liquid and steam installations using a side-port MVT and block manifold.
2. Connect the mounting bracket to the Scanner 2000 using the two bolts provided (Figure 2.4, page 29).
3. Position the U-bolt around the pipe and through the support bracket provided with the U-bolt.

4. Align the mounting bracket against the pole so that the U-bolt passes through the mounting holes in the bracket. Place the mounting plate over the threaded ends of the U-bolt and against the bracket, and secure the U-bolt with the two nuts provided.
5. Install and connect process piping between the Scanner 2000 and the turbine meter with appropriate fittings. Process piping installation procedures vary with each application.

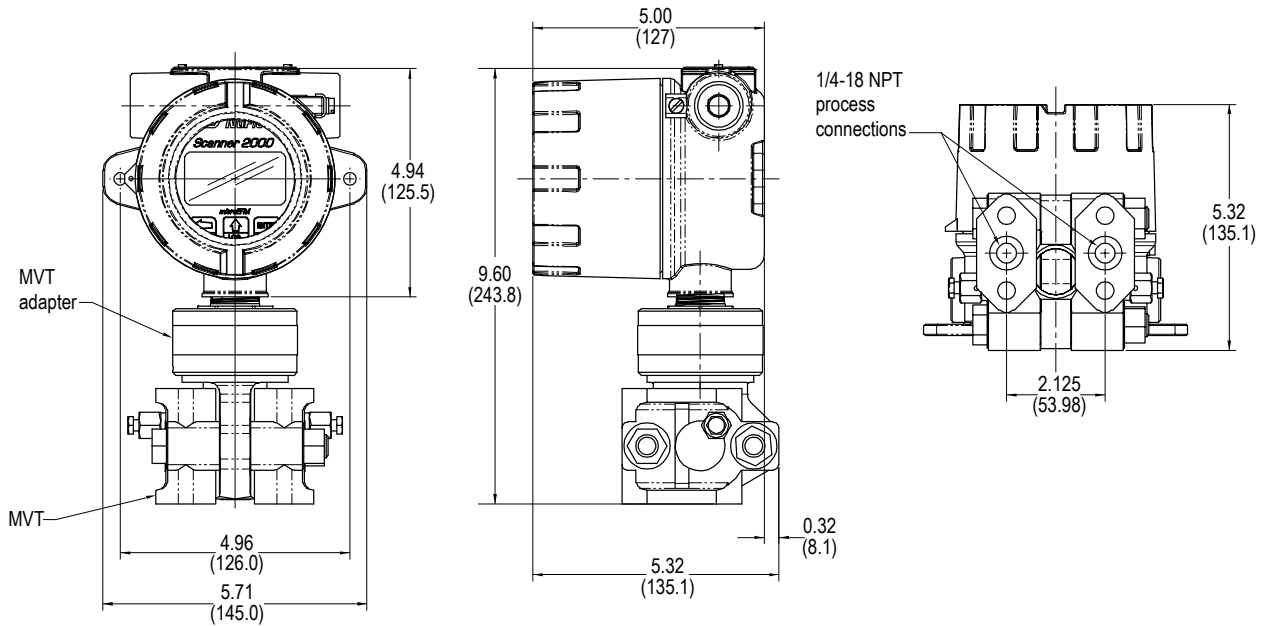

Figure 2.1—Scanner 2000 with direct-mount MVT (MVT with bottom ports shown)

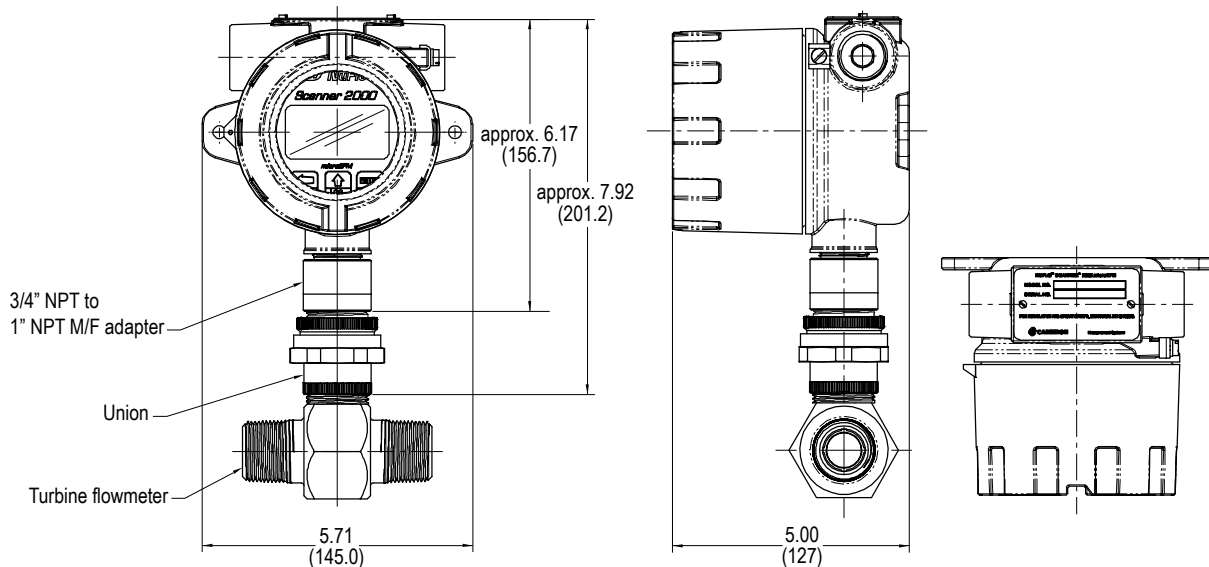

Figure 2.2—Scanner 2000 direct-mounted to a NuFlo turbine flowmeter (CSA-approved when direct-mounted to a NuFlo turbine flowmeter or a Barton 7000 Series flowmeter)

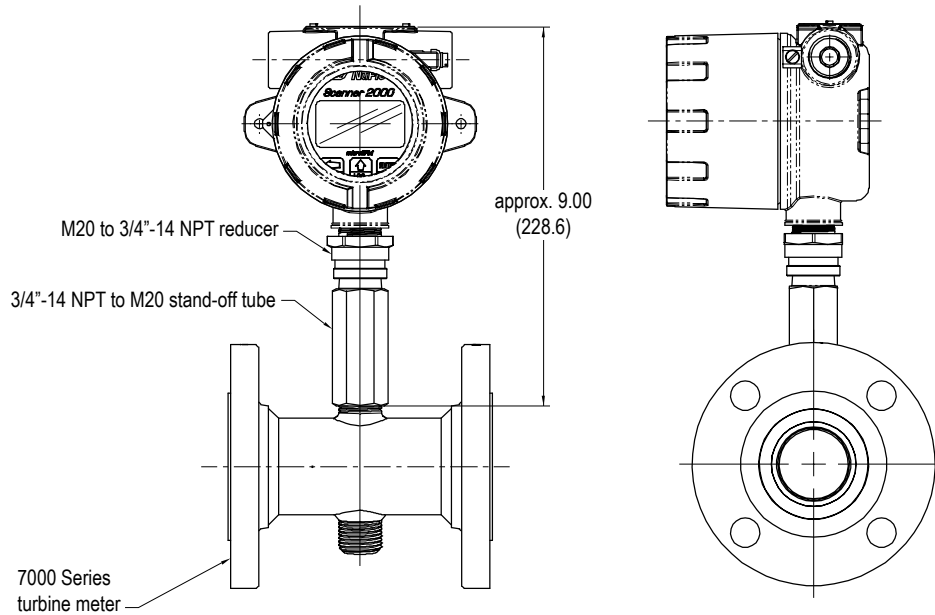

Figure 2.3—Scanner 2000 direct-mounted to a Barton 7000 Series flowmeter (ATEX-approved only when direct-mounted to a Barton 7000 Series flowmeter)

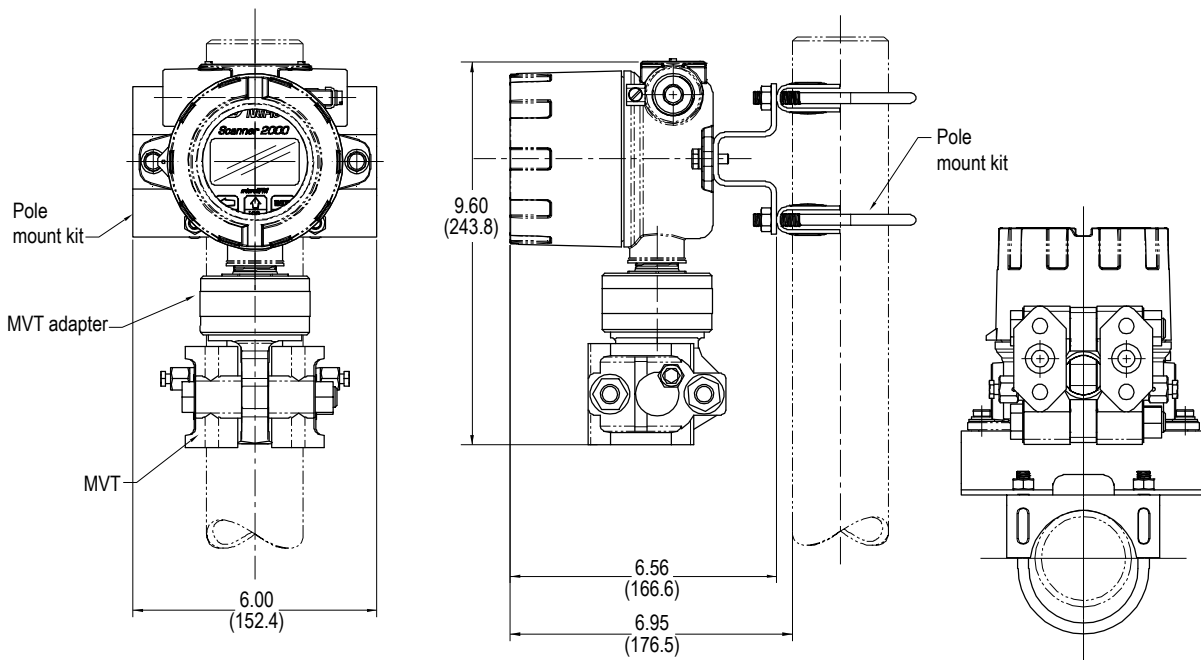

Figure 2.4—Scanner 2000 with MVT, remote-mounted on a 2-in. pole using a NuFlo hardware kit (Part No. 9A-30028004)

Important The vertical pipe mount configuration shown in Figure 2.4 is not recommended for side-port MVTs when mated with a block manifold for liquid or steam measurement. A horizontal pipe mount should be considered for these installations.

Measuring Natural Gas via a Differential Pressure Meter

Note This section contains installation guidelines for orifice and cone meters. If installing the Scanner 2000 with an averaging pitot tube meter, refer to manufacturer instructions for installation.

Best Practices for Orifice and Cone Meter Installation

To ensure measurement accuracy, ensure that the meter run complies with the following AGA-3 and ISO 5167 guidelines, as applicable:

- Do not place unit near vents or bleed holes that discharge corrosive vapors or gases.
- Consider the orientation of the meter run when determining the best position for mounting the Scanner 2000.
 - If the Scanner 2000 is mounted to a horizontal pipeline, make sure process connections are at the top of the line, and mount the Scanner 2000 above the pressure connections at the pipe.
 - If the Scanner 2000 is mounted to a vertical pipeline, install the sensor above the differential pressure source connections, or install a condensate (drip) pot to prevent the accumulation of liquid in inter-connecting tubes. Slope all tubing upward at least 1-inch/linear foot to avoid liquid entrapment.
- Mount the Scanner 2000 as near level as possible such that the operator has a clear view of the LCD, and can access the keypad easily when the enclosure cover is removed. The location should be as free from vibration as possible.
- Make sure the high port of the sensor (marked “H”) is connected to the upstream side of the meter run.
- Flow should remain subsonic throughout the measuring section and should be single phase.
- Pipe diameters (D) should be between 2 in. (50 mm) and 39 in. (1000 mm) per ISO 5167; or greater than 2 in. (50 mm) per AGA-3.
- Pipe Reynolds numbers must be above 5000.
- d (orifice diameter) must be greater than or equal to 0.45 in. (11.5 mm).
- β (diameter ratio) must be greater than or equal to 0.1 and less than or equal to 0.75.
- Gauge lines should be of uniform internal diameter and constructed of material compatible with the fluid being measured. For most applications, the bore should be no smaller than ¼ in. (6 mm) and preferably, 3/8 in. (10 mm) in diameter. The internal diameter should not exceed 1 in. (25 mm). If high-temperature fluids are likely to be encountered, make sure the measuring tube used is rated for the anticipated temperature range.
- Gauge line length should be minimized to help prevent pulsation-induced errors.
- Gauge lines should slope downward to the meter at a minimum of one inch per foot.
- If gauge lines must slope in more than one direction, do not allow more than one bend and install a liquid or gas trap, as applicable. A liquid trap should be installed at the lowest point in a gas service installation.
- Gauge lines should be supported to prevent sag and vibration.
- Where pulsation is anticipated, full-port manifold valves with a nominal internal diameter consistent with the gauge lines are recommended.

If the Scanner 2000 is mounted to a cone meter, consider the following best practices in addition to the best practices listed above.

- Position the cone meter so that there are zero to five pipe diameters upstream of the meter and zero to

three pipe diameters downstream of the meter.

- Install the meter so that the static pressure tap is upstream of the differential pressure tap. The high side of the integral Scanner 2000 sensor must also be situated upstream.
- Install shut-off valves directly on the DP meter pressure taps. Choose a shut-off valve that is rated for the ambient temperatures of the location and the operating pressure of the pipe in which it will be installed, and for use with dangerous or corrosive fluids or gases, if applicable. The valves must not affect the transmission of the differential pressure signal.

Installation Procedure—Direct Mount to Orifice Meter or Cone Meter

A Scanner 2000 can be mounted directly to an orifice meter or cone meter for gas measurement. The setup of the meter run and plumbing configurations can vary widely, depending upon the challenges existing on location. Figure 2.5 shows a typical direct-mount installation.

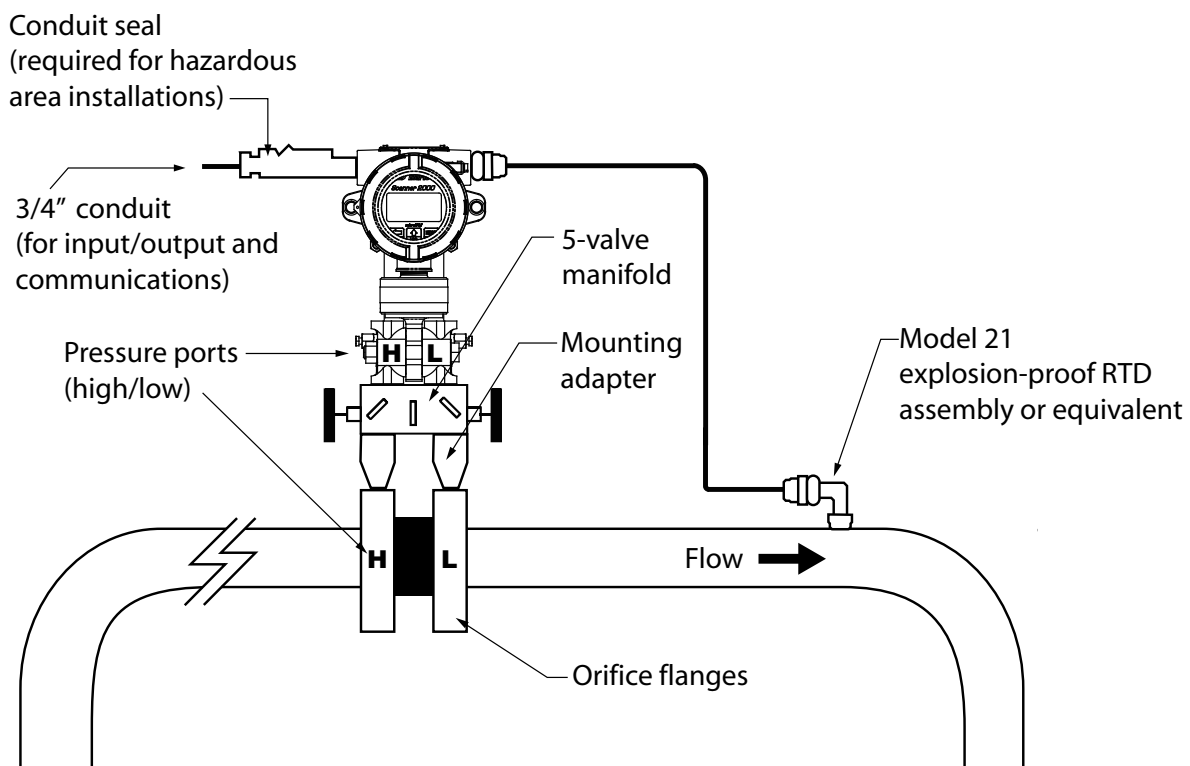

Figure 2.5—Direct-mount installation in an orifice meter run (shown here with an orifice meter). The direct-mount method can be used with a cone meter as well.

1. Verify that the meter is properly installed in the flow line (per manufacturer’s instructions).
2. Bolt a flange-by-flange 5-valve manifold (as recommended by Cameron) to the Scanner 2000 MVT sensor.
 - a. Locate the H and L markings on the integral MVT sensor body and position the MVT/manifold assembly so that the upstream side of the flow line can easily be connected to the sensor’s “High” port and the downstream side of the flow line can be connected to the sensor’s “Low” port. The Scanner 2000 enclosure can be rotated to face the desired direction.
 - b. Position the manifold so that all valves are accessible from the front of the instrument.

3. Connect the Scanner 2000 and manifold assembly to the differential pressure meter. Hardware requirements will vary, depending upon the installation configuration. However, minimally, an adapter is required that can span between the threaded pressure tap/orifice flange connector and the non-threaded manifold. This adapter can be a one-piece stabilizer (often preferred for added strength and stability) or a short heavy wall pipe nipple attached to a futbol flange (available from Cameron). Use a suitable compound or tape on all threaded process connections.
4. Install the explosion-proof Barton Model 21 RTD assembly in the thermowell. Route the RTD assembly cable through the conduit opening in the top of the Scanner 2000 to connect to the main circuit board. (If the Barton Model 21 assembly is not used and the Scanner 2000 is in a hazardous area, a Barton Model 20 RTD terminal housing or similar alternative must be used. In this case, the RTD signal cable must be routed through conduit and a conduit seal must be installed within 18 in. of the Scanner 2000. A wiring diagram for the RTD assembly is provided in .
5. Route any additional inputs/outputs or COM connections, etc. through the conduit opening in the top of the Scanner 2000. In hazardous environments, add a conduit seal within 18 inches of the Scanner 2000. Figure 3.5, page 64.
6. Perform a manifold leak test as described on page 52.
7. Verify the zero offset, if required (and other calibration points, if desired). See the ModWorX™ Pro Software User Manual, Part No. 9A-30165025, for complete instructions. See also Zero Offset (Static Pressure or Differential Pressure), page 53, Static Pressure Calibration and Verification, page 53, and Differential Pressure Calibration and Verification, page 54.

CAUTION Do not put the Scanner into operation until the valves are positioned properly so that pressure is supplied to both sides of the MVT. For instructions on proper valve positions, see *Placing the Scanner into Operation*, page 55.

Installation Procedure—Remote Mount to Orifice Meter or Cone Meter

A Scanner 2000 can be mounted remotely and connected to an orifice meter or cone meter with tubing for gas measurement. The setup of the meter run and plumbing configurations can vary widely, depending upon the challenges existing on location. Figure 2.6 shows a typical remote-mount installation.

Note To prevent fittings from turning and/or to avoid putting tension on stainless steel tubing, use a backup wrench to attach stainless steel tubing to a manifold, shut-off valves, or sensor ports.

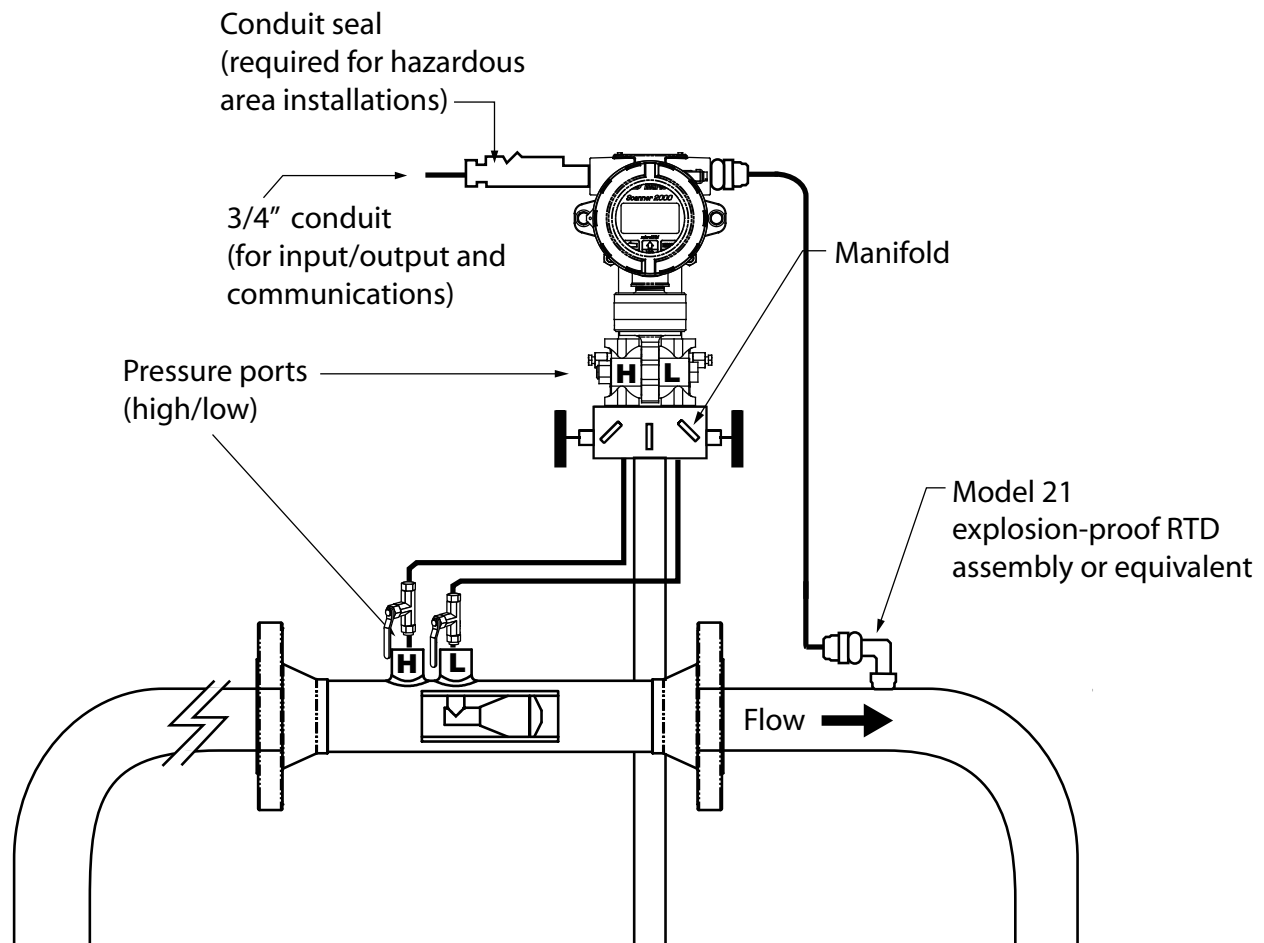

Figure 2.6—Remote-mount gas run installation (shown here with a cone meter). The remote-mount method can be used with an orifice meter as well.

1. Verify that the meter is properly installed in the flow line (per manufacturer's instructions).
2. Mount the Scanner 2000 to a 2-in. pipe or to a flat, vertical surface using bolts and the mounting holes in the enclosure.
3. Bolt a 5-valve flange-by-NPT manifold (as recommended by Cameron) to the Scanner 2000 MVT sensor.
 - a. Locate the H and L markings on the integral MVT sensor body and position the MVT/manifold assembly so that the upstream side of the flow line can easily be connected to the sensor's "High" port and the downstream side of the flow line can be connected to the sensor's "Low" port. The Scanner 2000 enclosure can be rotated to face the desired direction.

- b. Position the manifold so that all valves are accessible from the front of the instrument.
4. Install tubing and fittings to connect the Scanner 2000 and manifold assembly to the differential pressure meter, sloping the gauge lines downward to the meter at a minimum of one inch per foot. Use a suitable compound or tape on all threaded process connections.
5. Install the explosion-proof Barton Model 21 RTD assembly in the thermowell. Route the RTD assembly cable through the conduit opening in the top of the Scanner 2000 to connect to the main circuit board. (If the Barton Model 21 series is not used and the Scanner 2000 is in a hazardous area, a Barton Model 20 RTD terminal housing or similar alternative must be used. In this case, the RTD signal cable must be routed through conduit and a conduit seal must be installed within 18 in. of the Scanner 2000. A wiring diagram for the RTD assembly is provided in Figure 3.5, page 64.
6. Route any additional inputs/outputs or COM connections, etc. through the conduit opening in the top of the Scanner 2000. In hazardous environments, add a conduit seal within 18 in. of the Scanner 2000.
7. Perform a manifold leak test as described on page 52.
8. Verify the zero offset, if required (and other calibration points, if desired). See the ModWorX™ Pro Software User Manual, Part No. 9A-30165025, for complete instructions. See also Zero Offset (Static Pressure or Differential Pressure), page 53, Static Pressure Calibration and Verification, page 53, and Differential Pressure Calibration and Verification, page 54.

CAUTION Do not put the Scanner into operation until the valves are positioned properly so that pressure is supplied to both sides of the MVT. For instructions on proper valve positions, see *Placing the Scanner into Operation*, page 55.

Measuring Natural Gas via a Turbine Meter

Best Practices

The Scanner 2000 microEFM calculates gas flow through a turbine meter in accordance with AGA-7 and API 21.1 industry standards. For optimum performance, ensure that the turbine and Scanner 2000 installation complies with the industry recommendations listed below:

- Install the turbine flowmeter in the meter run such that there are 10 nominal pipe diameters upstream and five nominal pipe diameters downstream of the meter. Both inlet and outlet pipe should be of the same nominal size as the meter.
- Straightening vanes are recommended for eliminating swirl conditions. If used, they should be installed five pipe diameters upstream of the meter.
- Where an RTD is used to facilitate compensated gas measurement from a gas turbine meter, locate the RTD within five pipe diameters downstream of the meter outlet and upstream of any valve or flow restriction.

Installation Procedure—Remote Mount to a Turbine Meter

A Scanner 2000 can be mounted remotely and connected to a gas turbine meter for measuring gas in accordance with AGA-7 calculations. Figure 2.7, page 36, shows an installation in which the pressure input is provided by the integral MVT. Alternatively, if an optional expansion board is installed in the Scanner 2000, an external explosion-proof pressure transducer can be used to supply the pressure. See Installation Procedure—Direct Mount to a Turbine Meter (CSA Compliant), page 37, for more information.

The setup of the meter run and plumbing configurations can vary widely, depending upon the challenges existing on location.

To connect the Scanner 2000 to a turbine meter, perform the following steps:

1. Verify that the flowmeter and magnetic pickup are installed in the flow line.
2. Mount the Scanner 2000 to a 2-in. pipe or to a flat, vertical surface using bolts and the mounting holes in the enclosure.

Important For explosion-proof installations, armored MC-HL type cable must be used or standard cable must be run through conduit from the Scanner 2000 to the meter, and an explosion-proof seal must be installed within 18 in. of the enclosure.

3. Bolt a 3-valve flange-by-NPT manifold (as recommended by Cameron) to the Scanner 2000 MVT sensor. Position the manifold so that all valves are accessible from the front of the instrument.
4. Connect the pressure port of the turbine meter to either manifold process port with tubing. The unused pressure port can be used as a “vent” as required. Always leave the equalizer valves open to allow pressure to both sides of the MVT. Use a suitable compound or tape on all threaded process connections.
5. Remove the plug from the conduit opening in the top of the Scanner 2000 enclosure, route the turbine signal cable through the opening, and connect it to the main circuit board. A wiring diagram for the turbine input is provided in Figure 3.4, page 63. In hazardous environments, the signal cable must be routed through conduit and conduit seals must be installed within 18 inches of the turbine meter and within 18 inches of the Scanner 2000.

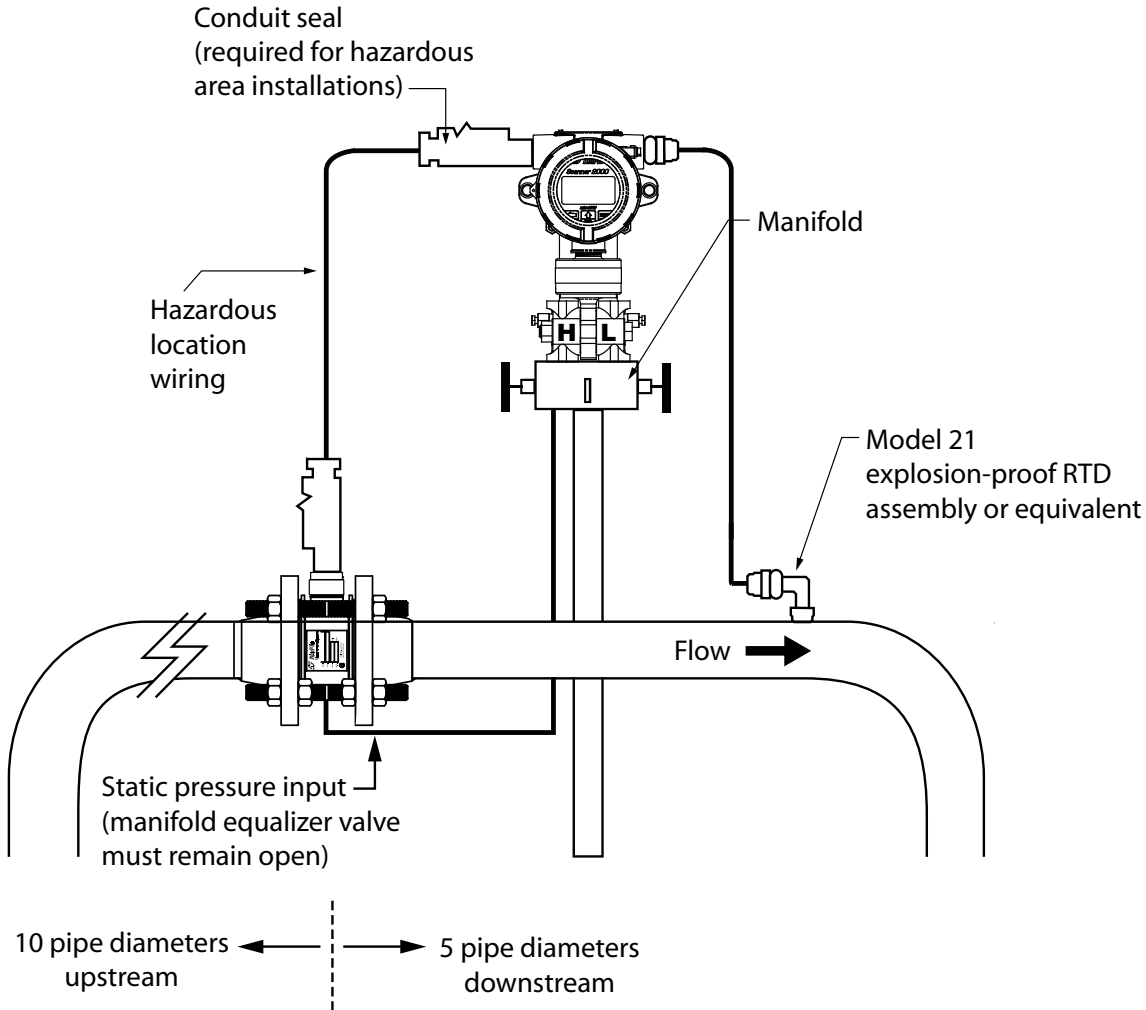

Figure 2.7—Remote-mount installation in an AGA-7 turbine meter run

6. Install the RTD assembly in the thermowell. Remove the plug from the other conduit opening in the top of the Scanner 2000 enclosure, route the RTD assembly cable through the conduit opening in the top of the Scanner 2000, and connect it to the main circuit board. A wiring diagram for the RTD assembly is provided in Figure 3.5, page 64.

Note If additional inputs/outputs or communication connections are required, a conduit box should be added to the installation.

7. Zero the static pressure and recalibrate the static pressure, if required. See the ModWorX™ Pro Software User Manual, Part No. 9A-30165025, for complete instructions. See also Zero Offset (Static Pressure or Differential Pressure), page 53, and Static Pressure Calibration and Verification, page 53.

CAUTION Do not put the Scanner into operation until the valves are positioned properly so that pressure is supplied to both sides of the MVT. For instructions on proper valve positions, see Placing the Scanner into Operation, page 55.

Installation Procedure—Direct Mount to a Turbine Meter (CSA Compliant)

A Scanner 2000 without the MVT bottomworks can be mounted directly to a gas turbine meter for measuring natural gas. A pipe adapter and union are attached to the Scanner, allowing a direct connection to the turbine meter.

An external explosion-proof pressure transducer is required for converting the pressure to a 4-20 mA or 1-5V signal, and the Scanner 2000 must be equipped with the optional expansion board, which provides the analog input necessary to receive the pressure signal from the transducer.

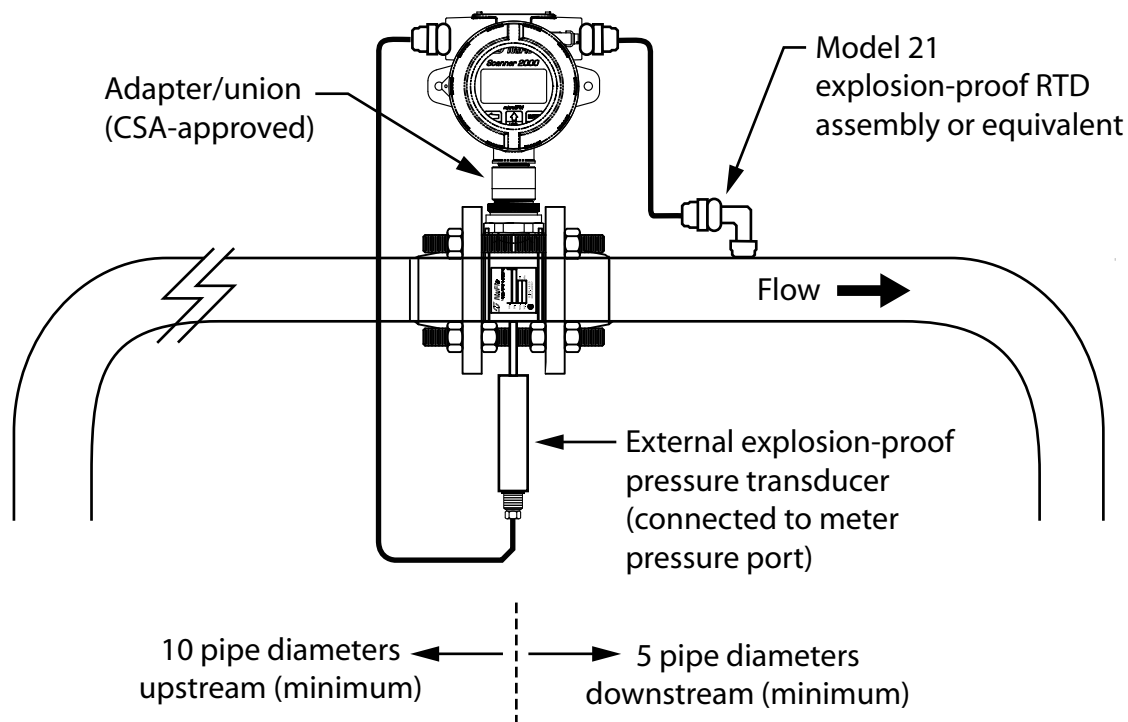

Figure 2.8—Direct-mount installation for use with a gas turbine meter

To connect the Scanner 2000 to a turbine meter using this method, perform the following steps:

1. Position the Scanner 2000 above the gas turbine flowmeter.
2. Plug the Scanner 2000 cable connector into the magnetic pickup of the turbine meter and hand-tighten the knurled nut on the connector.
3. Screw the Scanner 2000 onto the flowmeter threads surrounding the magnetic pickup with the display facing the desired direction.
4. Tighten all sections of the pipe union.
5. Connect the pressure port of the turbine meter to the external pressure transducer.
6. Remove the plug from the conduit opening in the top of the Scanner 2000 enclosure, route the cable from the pressure transducer through the opening, and connect it to the analog input terminal of the expansion circuit board. A wiring diagram for the analog input is provided in Figure A.15, page A-10. In hazardous environments, the cable must be routed through conduit and conduit seals must be installed within 18 inches of the turbine meter and within 18 inches of the Scanner 2000.

7. Install the RTD assembly in the thermowell. Remove the plug from the other conduit opening in the top of the Scanner 2000 enclosure, route the RTD assembly cable through the conduit opening in the top of the Scanner 2000, and connect it to the main circuit board. A wiring diagram for the RTD assembly is provided in Figure 3.5, page 64.

CAUTION Do not use Teflon® tape on the threads of the union, adapter, or pipe plugs. Use of Teflon® tape will void the explosion-proof rating of the instrument.

Measuring Steam via a Differential Pressure Meter

Note This section contains installation guidelines for orifice and cone meters. If installing the Scanner 2000 with an averaging pitot tube meter, refer to manufacturer instructions for installation.

Best Practices

The Scanner 2000 microEFM calculates steam flow in accordance with IF-97, AGA-3, and ISO-5167 industry standards. For optimum performance, ensure that the Scanner 2000 installation complies with the industry recommendations listed below:

Condensate pots

- A condensate pot for a small-volume transducer like the Scanner 2000 MVT can be a simple pipe tee, oriented so that one port extends downward (into the cold leg), the opposite port extends upward and is closed by a pipe cap or blowdown valve, and the tee extends horizontally into the hot leg.
- The pots should be the highest point in the system.
- The pots should be mounted at the same level, and one or both should be adjustable vertically to remove zero shifts in the differential pressure measurement.

Hot legs

- Hot legs should be large diameter (3/8 in. or 1/2 in., if possible)
- Hot legs should be as short as possible. If these sections must be more than 1 ft. in length, insulate them.
- Elbows and bends should not form any traps in which liquid can accumulate.
- Hot legs should be sloped along their entire length to allow liquids to drain back into the pipe.

Cold legs

- Cold legs should enter the multi-variable sensor through its side ports.
- Cold legs should be a minimum of 2 ft in length to allow proper convection cooling and should be run horizontally with a slope of approximately 1 inch per foot to allow air bubbles to float up into the pots.
- Elbows and bends should not form any traps for air bubbles.
- Cold legs should be filled with a suitable antifreeze. Dibutyl phthalate is recommended.

Antifreeze

- Dibutyl phthalate (DBP) has the following advantages over glycol antifreeze:
 - DBP doesn't mix with water, and so doesn't become dilute over time; its specific gravity doesn't shift.
 - It is slightly denser than water, so it will stay in the pot permanently.
 - It is non-flammable.
 - It is much less toxic than glycol.
 - It is available from industrial suppliers.

Valves

- Use only full-opening block valves that are rated for steam service.
- Use only blowdown valves that are rated for steam service. Periodic blowdowns are recommended for preventing buildup of scale.

CAUTION Before starting the system, remove the caps and add water or antifreeze if necessary to completely fill the pots and cold legs. Air trapped in the lines will produce errors in differential pressure measurements.

Installation Procedure—Remote Mount to Orifice Meter or Cone Meter

A Scanner 2000 can be mounted remotely and connected to an orifice meter or cone meter with tubing for steam measurement. The setup of the meter run and plumbing configurations can vary widely, depending upon the challenges existing on location.

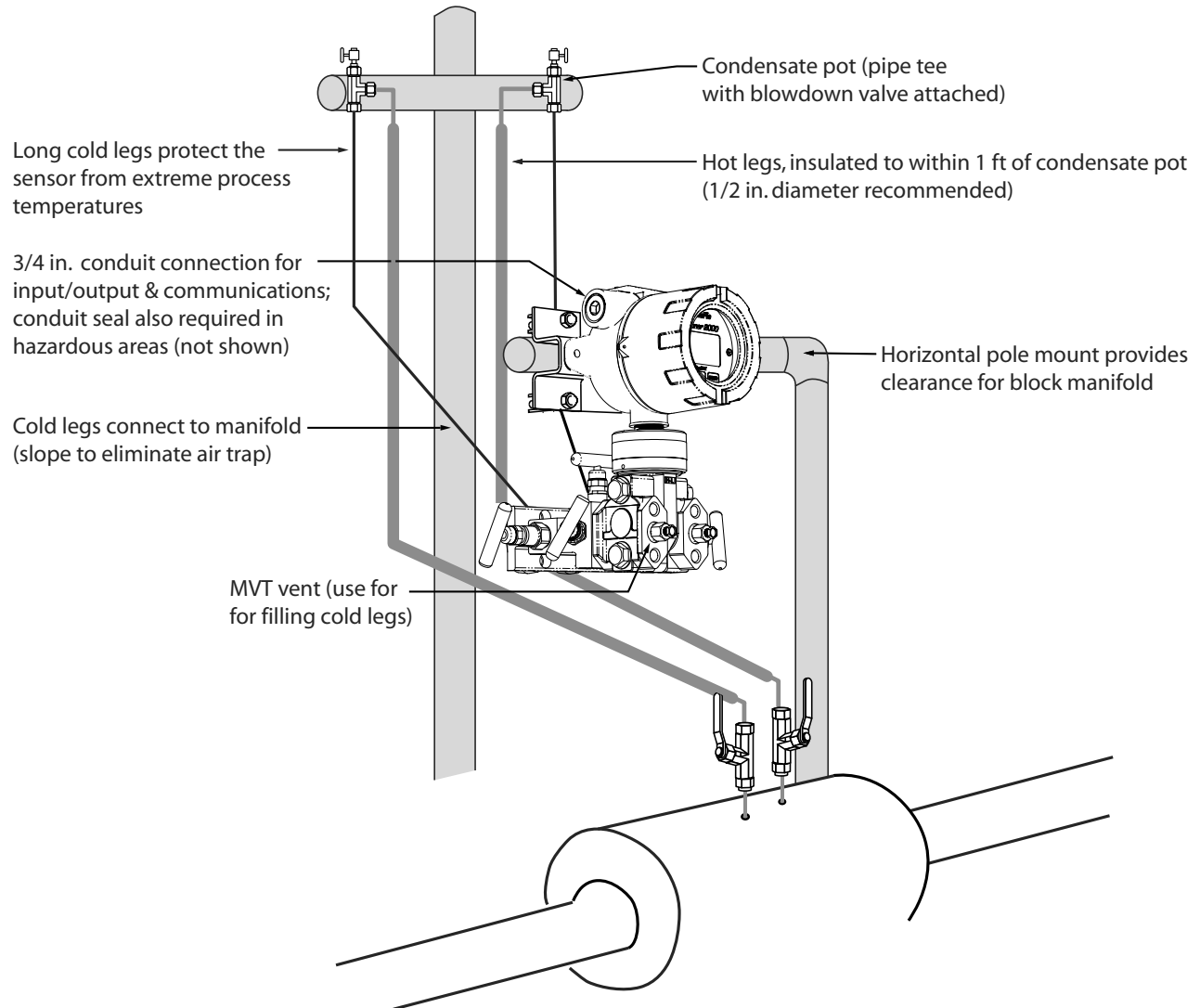

Figure 2.9—Remote-mount steam run installation (shown here with a cone meter). The remote-mount method can be used with an orifice meter as well.

CAUTION When measuring steam, process connections must be designed to eliminate air pockets. This is achieved by making sure all tubing in the cold legs slopes upward. A side-port MVT and block manifold (shown in Figure 2.9) is recommended to help prevent air bubbles from being trapped in the sensor.

If a bottom-port MVT is used, the bottom process ports must be plugged or replaced with a drain valve, and side vents must be used for process connections. A block manifold is not recommended for use with bottom port MVTs. Contact a Cameron field representative for assistance.

1. Verify that the meter is properly installed in the flow line (per manufacturer's instructions).
2. Mount the Scanner 2000 to a 2-in. pipe or to a flat, vertical surface using bolts and the mounting holes in the enclosure. A horizontal pipe is recommended, as additional hardware may be required for a vertical pipe mount to provide clearance for the manifold block.
3. Mount a set of pipe tees (which serve as condensate pots) typically on either side of the Scanner 2000 at an elevation above the process connections of the Scanner 2000 MVT (for proper drainage). They should be a considerable distance (4 ft) from the sensor ports, but as close as possible to the pressure taps on the meter.
4. Install a pipe cap or a blowdown valve that is rated for steam service at the top of each pipe tee. A blowdown valve is recommended when the steam passing through the meter is known to be dirty.
5. Install tubing and fittings to connect the high-pressure and low-pressure taps of the DP meter to the pipe tees. This section is typically referred to as the *hot legs* of the installation, as this section of tubing encounters steam at its highest temperature. Install a shut-off valve near the high and low ports of the DP meter. Use a suitable compound or tape on all threaded process connections.
6. Route any additional inputs/outputs or COM connections, etc. through the conduit opening in the top of the Scanner 2000. In hazardous environments, add a conduit seal within 18 in. of the Scanner 2000.

Note: To prevent fittings from turning and/or to avoid putting tension on stainless steel tubing, use a backup wrench to attach stainless steel tubing to shut-off valves, or sensor ports.

CAUTION Whenever possible, locate the hot legs of a steam installation behind the Scanner 2000 safely out of the operator's normal reach. This will help prevent accidental burns.

7. Install tubing to connect the high-pressure and low-pressure process connections of the block manifold to the pipe tees installed in step 3. This tubing section is typically referred to as the *cold legs* of the installation, since it is filled with water.
8. To eliminate air bubbles, fill the cold legs with water or other fill fluid from the lowest point in the system, typically the MVT, using the following steps:
 - a. Open the blowdown valve or remove the filling plug from one of the pipe tees/condensate pots.
 - b. Open the equalizer and bypass/block valves on the block manifold. Make sure the vent valve is closed.
 - c. Remove the corresponding (high pressure or low pressure) vent screw from the side of the MVT and insert a fitting to allow connection of a hand pump or funnel. If a funnel is used, attach a length of Tygon tubing that is long enough to elevate the funnel well above the condensate pot to force the fluid up the legs.

- d. Connect a hand pump or funnel to the fitting.
 - e. Pour fill liquid into the funnel or pump it into the cold leg, tapping the cold leg occasionally to dislodge any bubbles.
 - f. Observe the pipe tee/condensate pot and stop pouring when the fill liquid is visible at the top and no air bubbles can be seen.
 - g. Remove the fitting from the vent of the MVT and quickly replace the vent screw and tighten.
 - h. Close the blowdown valve or replace the filling plug from one of the pipe tees/condensate pots.
 - i. Repeat steps a through h for the other cold leg.
9. To eliminate an offset of the differential pressure reading, open the equalizer valves on the block manifold, remove the caps from the seal pots, and adjust either seal pot vertically to bring the water levels to the exact same elevation.
 10. Perform a manifold leak test as described on page 52.
 11. Verify the zero offset, if required (and other calibration points, if desired). See the ModWorX™ Pro Software User Manual, Part No. 9A-30165025, for complete instructions. See also *Zero Offset (Static Pressure or Differential Pressure)*, page 53, *Static Pressure Calibration and Verification*, page 53, and *Differential Pressure Calibration and Verification*, page 54.

CAUTION Do not put the Scanner into operation until the valves are positioned properly so that pressure is supplied to both sides of the MVT. For instructions on proper valve positions, see *Placing the Scanner into Operation*, page 55.

Measuring Liquid via a Differential Pressure Meter

Note This section contains installation guidelines for orifice and cone meters. If installing the Scanner 2000 with an averaging pitot tube meter, refer to manufacturer instructions for installation.

Best Practices

To ensure measurement accuracy, ensure that the meter run complies with the following AGA-3 and ISO 5167 guidelines, as applicable:

- Do not place unit near vents or bleed holes that discharge corrosive vapors or gases.
- Consider the orientation of the meter run when determining the best position for mounting the Scanner.
 - If the Scanner 2000 is mounted to a horizontal pipeline, make sure process connections are horizontal with the pipeline, or sloped downwards towards the Scanner. Mount the Scanner 2000 below the pressure taps at the pipe. Use the side (upper) ports as process connections and the bottom ports for draining and filling the DP housings.
 - If the Scanner 2000 is mounted to a vertical pipeline, install the sensor below the differential pressure source connections. Slope all tubing downward at least 1-inch/linear foot to avoid gas entrapment.
- Mount the Scanner 2000 as near level as possible such that the operator has a clear view of the LCD, and can access the keypad easily when the enclosure cover is removed. The location should be as free from vibration as possible.
- Make sure the high port of the sensor (marked “H”) is connected to the upstream side of the meter run.
- Pipe diameters (D) should be between 2 in. (50 mm) and 39 in. (1000 mm) per ISO 5167; or greater than 2 in. (50 mm) per AGA-3.
- Pipe Reynolds numbers must be above 5000. Avoid high-viscosity liquids (greater than 15 cP).
- d (orifice diameter) must be greater than or equal to 0.45 in. (11.5 mm).
- Orifice β (diameter ratio) must be greater than or equal to 0.1 and less than or equal to 0.75.
- Gauge lines should be of uniform internal diameter and constructed of material compatible with the fluid being measured. For most applications, the bore should be no smaller than ¼ in. (6 mm) and preferably, 3/8 in. (10 mm) in diameter. The internal diameter should not exceed 1 in. (25 mm). If high-temperature fluids are likely to be encountered, make sure the measuring tube used is rated for the anticipated temperature range.
- If there is possibility of freezing, the gauge lines can be filled with a suitable seal liquid. The seal liquid should be somewhat denser than the process fluid, should not dissolve in it, should have a sufficiently low freezing point, and should be non-toxic. Alternatively, heat tracing can be used.
- Gauge line length should be minimized to help prevent pulsation-induced errors.
- Gauge lines should slope upward to the meter at a minimum of one inch per foot.
- If gauge lines must slope in more than one direction, do not allow more than one bend and install a gas trap.
- Gauge lines should be supported to prevent sag and vibration.
- Where pulsation is anticipated, full-port manifold valves with a nominal internal diameter consistent with the gauge lines are recommended.

If the Scanner 2000 is mounted to a cone meter, consider the following guidelines in addition to the best

practices listed above.

- Position the cone meter so that there are zero to five pipe diameters upstream of the meter and zero to three pipe diameters downstream of the meter.
- Install the meter so that the static pressure tap is upstream of the differential pressure tap. The high side of the integral Scanner 2000 sensor must also be situated upstream.
- Install shut-off valves directly on the DP meter pressure taps. Choose a shut-off valve that is rated for the ambient temperatures of the location and the operating pressure of the pipe in which it will be installed, and for use with dangerous or corrosive fluids or gases, if applicable. The valves must not affect the transmission of the differential pressure signal.

Installation Procedure—Direct Mount to Orifice Meter or Cone Meter

A Scanner 2000 can be mounted directly to an orifice meter or cone meter for liquid measurement using a side-port MVT, a block manifold and two football flange adapters (Figure 2.10). The setup of the meter run and plumbing configurations can vary widely, depending upon the challenges existing on location.

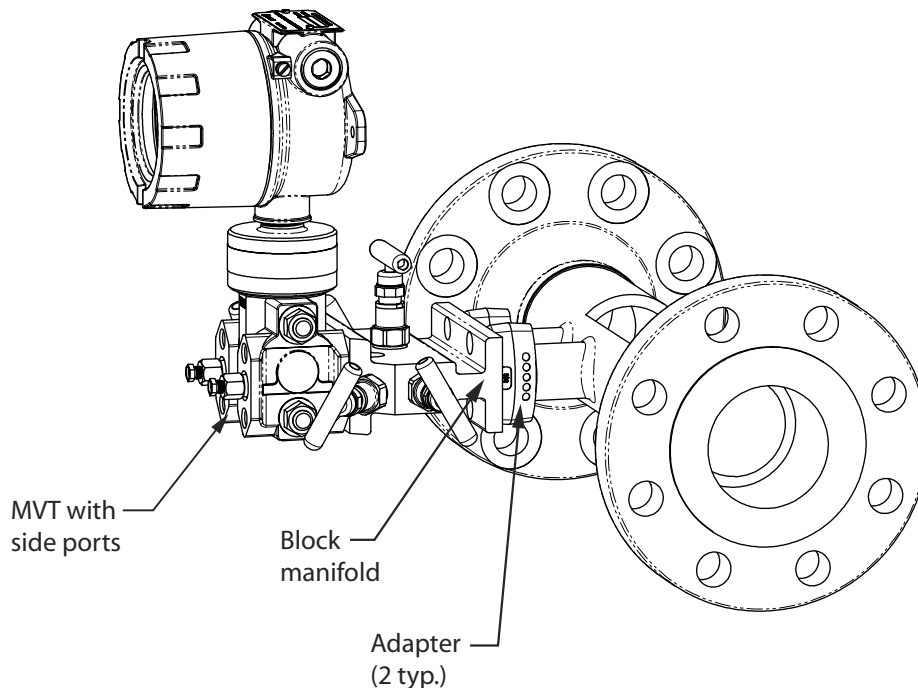

Figure 2.10—Direct-mount liquid run installation (shown here with a cone meter). Downstream RTD is not shown.

CAUTION When measuring liquid with a direct-mount Scanner 2000, process connections must be parallel to the horizontal centerline of the meter, or below the centerline to eliminate air pockets.

1. Verify that the meter is properly installed in the flow line (per manufacturer's instructions).
2. Screw a football flange adapter onto each meter pressure tap using pipe tape or pipe dope to seal the threads.

3. Align the bolt holes in the Scanner 2000 MVT and manifold, and install bolts to mate these components to the football flanges, using o-rings as appropriate. Torque the bolts to the manufacturer's specification.
4. Route any additional inputs/outputs or COM connections, etc. through the conduit opening in the top of the Scanner 2000. In hazardous environments, add a conduit seal within 18 in. of the Scanner 2000.
5. Verify that all manifold valves are closed, and fill the meter with process fluid.
6. Loosen one of the vent screws in the side of the MVT.
7. Open the equalizer valves and the vent valve on the manifold.
8. Slowly open one of the bypass/block valves on the manifold. Process fluid should immediately spurt from the MVT vent.
9. When air bubbles are no longer visible around the MVT vent, tighten the MVT vent screw.
10. Loosen the other vent screw in the side of the MVT, and repeat steps 7 through 9.
11. Perform a manifold leak test as described on page 52.
12. Verify the zero offset, if required (and other calibration points, if desired). See the ModWorX™ Pro Software User Manual, Part No. 9A-30165025, for complete instructions. See also Zero Offset (Static Pressure or Differential Pressure), page 53, Static Pressure Calibration and Verification, page 53, and Differential Pressure Calibration and Verification, page 54.

CAUTION Do not put the Scanner into operation until the valves are positioned properly so that pressure is supplied to both sides of the MVT. For instructions on proper valve positions, see *Placing the Scanner into Operation*, page 55.

Installation Procedure—Remote Mount to Orifice Meter or Cone Meter

A Scanner 2000 can be mounted remotely and connected to an orifice meter or cone meter with tubing for liquid measurement (Figure 2.11). The setup of the meter run and plumbing configurations can vary widely, depending upon the challenges existing on location.

CAUTION When measuring liquid, process connections must be designed to eliminate air pockets. This is achieved by mounting the sensor below the metering device and sloping all tubing downward from the meter to the sensor. A side-port MVT and block manifold (shown in Figure 2.11) is recommended to help prevent air bubbles from being trapped in the sensor.

If a bottom-port MVT is used, the bottom process ports must be plugged or replaced with a drain valve, and side vents must be used for process connections. A block manifold is not recommended for use with bottom port MVTs. Contact a Cameron field representative for assistance.

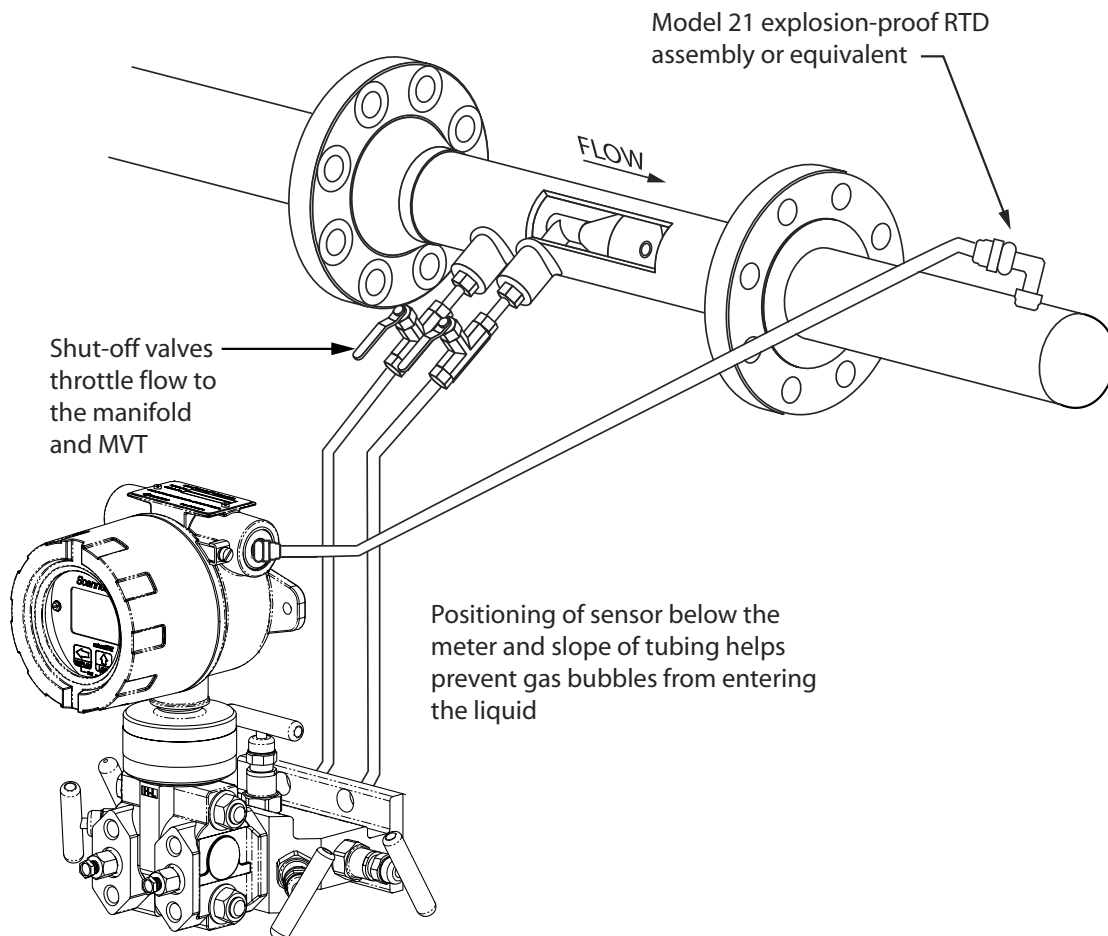

Figure 2.11—Remote-mount liquid run installation (shown here with a cone meter). The remote-mount method can be used with an orifice meter as well.

1. Verify that the meter is properly installed in the flow line (per manufacturer's instructions).
2. Mount the Scanner 2000 to a 2-in. pipe or to a flat, vertical surface using bolts and the mounting holes in the enclosure. A horizontal pipe is recommended, as additional hardware may be required for a vertical pipe mount to provide clearance for the manifold block.
3. Install tubing and fittings to connect the high-pressure and low-pressure taps of the DP meter to the process connections of the block manifold. Install a pair of shut-off valves near the high and low ports of the DP meter. Use a suitable compound or tape on all threaded process connections.
4. Route any additional inputs/outputs or COM connections, etc. through the conduit opening in the top of the Scanner 2000. In hazardous environments, add a conduit seal within 18 in. of the Scanner 2000.

Note To prevent fittings from turning and/or to avoid putting tension on stainless steel tubing, use a backup wrench to attach stainless steel tubing to shut-off valves, or sensor ports.

5. To eliminate air bubbles in the MVT, manifold, and legs connecting them to the meter, fill the legs with fluid. Choose a fluid that is safe for the environment, and stable when depressurized.

Important If the process fluid does not present an environmental risk and is stable when depressurized, it may be used to bleed air from the lines. If the process fluid can contaminate the environment, or is highly volatile when depressurized as with liquified gases, a different seal fluid should be used to fill the legs. An ideal seal fluid is one that does not dissolve in the process fluid.

Bleeding with Process Fluid

- a. Make sure the shut-off valves in the tubing near the meter pressure taps are closed, and the meter is filled with process fluid.
- b. Open the equalizer and bypass/block valves on the block manifold. Make sure the vent valve is closed.
- c. Open one of the shut-off valves near the meter.
- d. Slowly loosen the corresponding vent screw on the MVT, and throttle the rate of flow from the vent with the shut-off valve.
- e. When air bubbles are no longer visible around the MVT vent, tighten the MVT vent screw.
- f. Repeat steps a through e for the other leg.

Bleeding with a Different Seal Fluid

- a. Make sure the shut-off valves in the tubing near the pressure taps are open.
- b. Open the equalizer and bypass/block valves on the block manifold. Make sure the vent valve is closed.
- c. Remove the vent screw from one side of the MVT and insert a fitting to allow connection of a hand pump or funnel. If a funnel is used, attach a length of Tygon tubing that is long enough to elevate the funnel well above the meter pressure taps to force the fluid up the legs.

- d. Connect a hand pump or funnel to the fitting.
 - e. Estimate the amount of fill fluid required to fill the tubing and push any air bubbles into the meter.
 - f. Pour fill liquid into the funnel, tapping the tubing occasionally to dislodge any bubbles.
 - g. When the leg is full of fluid, remove the fitting from the vent of the MVT and quickly replace the vent screw and tighten.
 - h. Repeat steps a through g for the other leg.
6. Perform a manifold leak test as described on page 52.
 7. Verify the zero offset, if required (and other calibration points, if desired). See the ModWorX™ Pro Software User Manual, Part No. 9A-30165025, for complete instructions. See also Zero Offset (Static Pressure or Differential Pressure), page 53, Static Pressure Calibration and Verification, page 53, and Differential Pressure Calibration and Verification, page 54.

CAUTION Do not put the Scanner into operation until the valves are positioned properly so that pressure is supplied to both sides of the MVT. For instructions on proper valve positions, see *Placing the Scanner into Operation*, page 55.

Measuring Compensated Liquid via a Turbine Meter

Best Practices

The Scanner 2000 microEFM calculates compensated liquid flow through a turbine meter in accordance with API-2540 and the measurement principles upon which the AGA-7 standard is based. The user supplies a linear or multi-point calibration factor, and the instrument performs the required compensation calculations, based on the RTD input.

For optimum performance, ensure that the turbine and Scanner 2000 installation complies with the industry recommendations listed below:

- Install the turbine flowmeter in the meter run such that there are at least 10 nominal pipe diameters upstream and five nominal pipe diameters downstream of the meter. Both inlet and outlet pipe should be of the same nominal size as the meter.
- Straightening vanes are recommended for eliminating swirl conditions. If used, they should be installed five pipe diameters upstream of the meter.

Installation Procedure—Direct Mount to a Turbine Meter (CSA Compliant)

A Scanner 2000 without the MVT bottomworks can be mounted directly to a liquid turbine meter for measuring liquid (Figure 2.12). A pipe adapter and union are attached to the Scanner, allowing a direct connection to the turbine meter. An explosion-proof RTD is required for the temperature input.

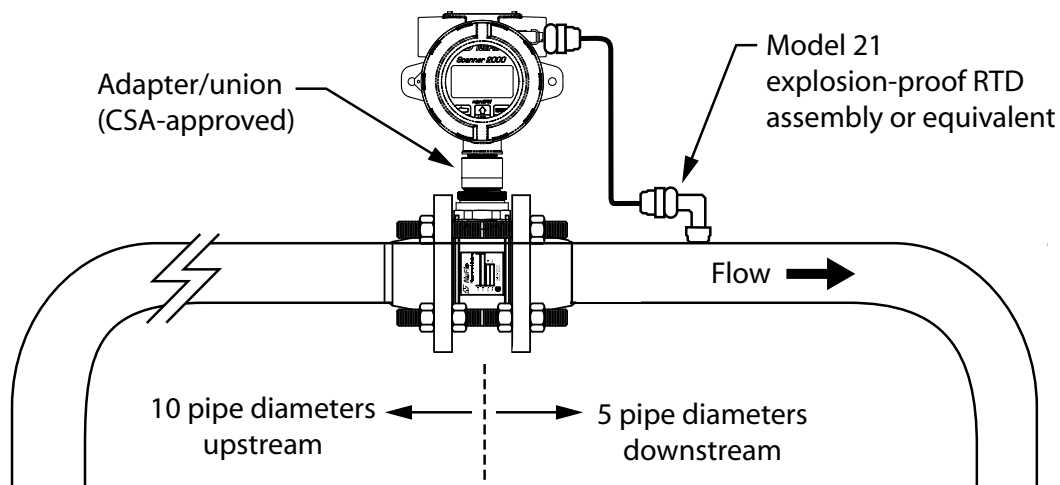

Figure 2.12—Direct-mount installation for use with a Barton 7000 Series meter

To connect the Scanner 2000 to a liquid turbine meter using this method, perform the following steps:

1. Position the Scanner 2000 above the flowmeter.
2. Plug the Scanner 2000 cable connector into the magnetic pickup of the turbine meter and hand-tighten the knurled nut on the connector.
3. Screw the Scanner 2000 onto the flowmeter threads surrounding the magnetic pickup with the display facing the desired direction.
4. Tighten all sections of the pipe union.

5. Install the RTD assembly in the thermowell. Remove the plug from a conduit opening in the top of the Scanner 2000 enclosure, route the RTD assembly cable through the conduit opening and connect it to the main circuit board. A wiring diagram for the RTD assembly is provided in Figure 3.5, page 64.

CAUTION Do not use Teflon® tape on the threads of the union, adapter, or pipe plugs. Use of Teflon® tape will void the explosion-proof rating of the instrument.

Installation Procedure—Direct Mount to a Barton 7000 Series Turbine Meter (ATEX Compliant)

A Scanner 2000 without the MVT bottomworks can be mounted directly to a Barton 7000 series turbine meter for measuring liquid (Figure 2.13). A stainless steel turbine meter pickup extension supports the Scanner 2000 and provides the elevation necessary for good visibility of the display. An explosion-proof RTD is required for the temperature input.

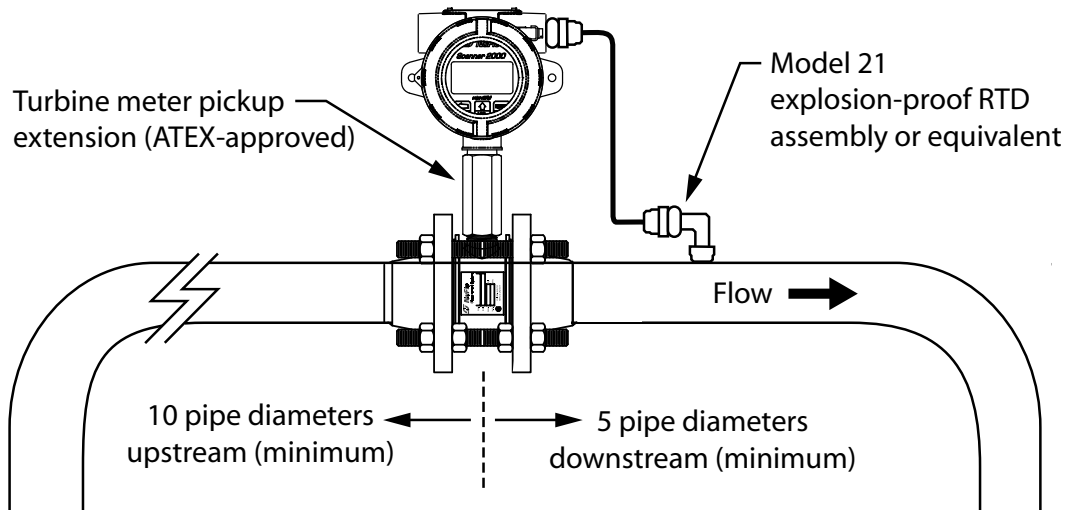

Figure 2.13—Direct-mount installation for use with a Barton 7000 Series meter

To connect the Scanner 2000 to a turbine meter using this method, perform the following steps:

1. Position the Scanner 2000 and pickup extension assembly above the flowmeter.
2. Plug the Scanner 2000 cable connector into the magnetic pickup of the turbine meter and hand-tighten the knurled nut on the connector.
3. Screw the Scanner 2000/pickup extension assembly onto the flowmeter threads surrounding the magnetic pickup with the display facing the desired direction, and tighten.
4. Install the RTD assembly in the thermowell. Remove the plug from a conduit opening in the top of the Scanner 2000 enclosure, route the RTD assembly cable through the conduit opening and connect it to the main circuit board. A wiring diagram for the RTD assembly is provided in Figure 3.5, page 64.

Measuring Uncompensated Liquid via a Turbine Meter

Best Practices

The Scanner 2000 microEFM calculates uncompensated liquid flow through a turbine meter in accordance with API MPMS, Chapter 5, Section 3, Measurement of Liquid Hydrocarbons by Turbine Meters. For optimum performance, ensure that the turbine and Scanner 2000 installation complies with the industry recommendations listed below:

- Install the turbine flowmeter in the meter run such that there are at least 10 nominal pipe diameters upstream and five nominal pipe diameters downstream of the meter. Both inlet and outlet pipe should be of the same nominal size as the meter.
- Straightening vanes are recommended for eliminating swirl conditions. If used, they should be installed five pipe diameters upstream of the meter.

Installation Procedure—Direct Mount to a Turbine Meter (CSA Compliant)

A Scanner 2000 without the MVT bottomworks can be mounted directly to a liquid turbine meter for measuring liquid (Figure 2.14). A pipe adapter and union are attached to the Scanner, allowing a direct connection to the turbine meter.

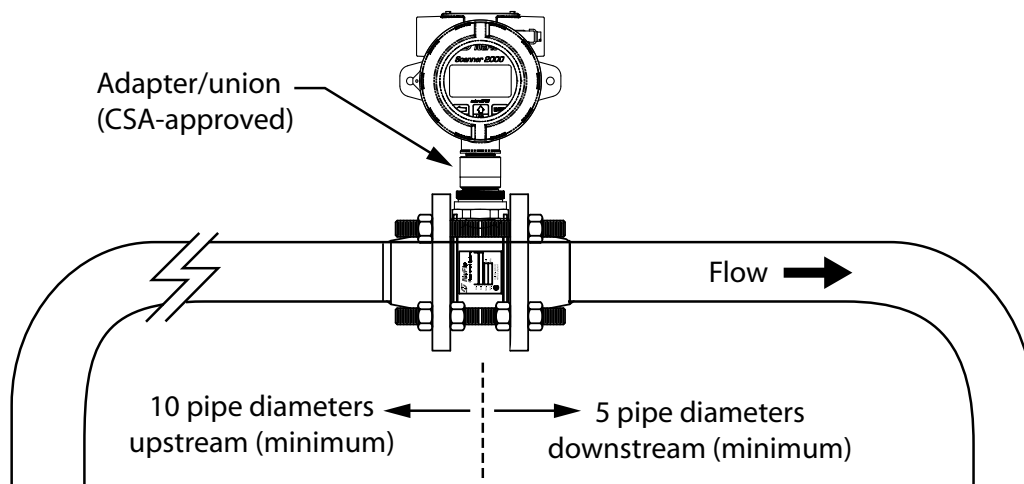

Figure 2.14—Direct-mount installation for use with a Barton 7000 Series meter

To connect the Scanner 2000 to a liquid turbine meter using this method, perform the following steps:

1. Position the Scanner 2000 above the flowmeter.
2. Plug the Scanner 2000 cable connector into the magnetic pickup of the turbine meter and hand-tighten the knurled nut on the connector.
3. Screw the Scanner 2000 onto the flowmeter threads surrounding the magnetic pickup with the display facing the desired direction.
4. Tighten all sections of the pipe union.

CAUTION Do not use Teflon® tape on the threads of the union, adapter, or pipe plugs. Use of Teflon® tape will void the explosion-proof rating of the instrument.

Installation Procedure—Direct Mount to a Barton 7000 Series Turbine Meter (ATEX Compliant)

A Scanner 2000 without the MVT bottomworks can be mounted directly to a Barton 7000 series turbine meter for measuring liquid (Figure 2.15). A stainless steel turbine meter pickup extension supports the Scanner 2000 and provides the elevation necessary for good visibility of the display.

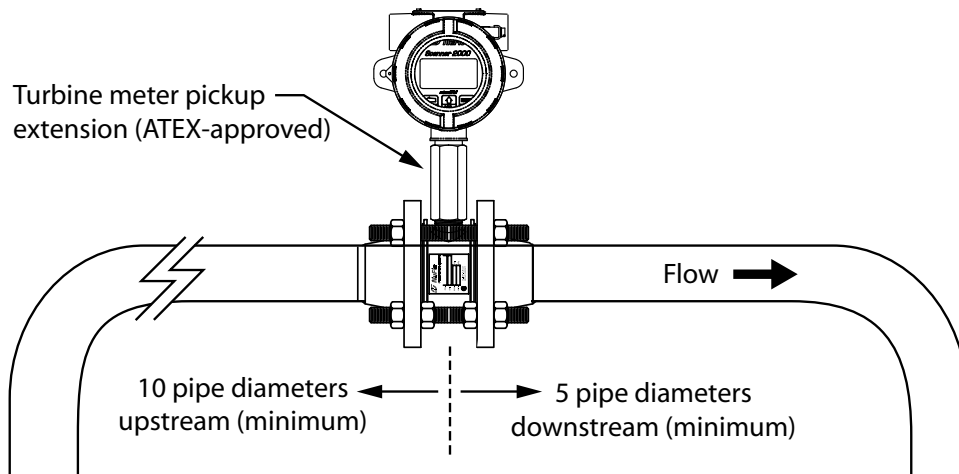

Figure 2.15—Direct-mount installation for use with a Barton 7000 Series meter

To connect the Scanner 2000 to a turbine meter using this method, perform the following steps:

1. Position the Scanner 2000 and pickup extension assembly above the flowmeter.
2. Plug the Scanner 2000 cable connector into the magnetic pickup of the turbine meter and hand-tighten the knurled nut on the connector.
3. Screw the Scanner 2000/pickup extension assembly onto the flowmeter threads surrounding the magnetic pickup with the display facing the desired direction, and tighten.

Performing a Manifold Leak Test

A manifold leak test is recommended prior to operating any differential pressure meter into service. Check the manifold for leaks as follows.

1. Verify that the instrument is approximately level and is properly connected to the pressure source.
2. Make sure the vent valve in the manifold is closed. (The bypass/block valves should be open.)
3. Close both bypass/block valves on the manifold to isolate pressure between the block valve and the MVT.
4. Open both equalizer valves to distribute pressure throughout.
5. Monitor the pressure readout and watch for a steady decrease in pressure. If leakage is indicated, depressurize the system by opening both bypass/block valves, then check all manifold and piping joints. Tighten connections as necessary.

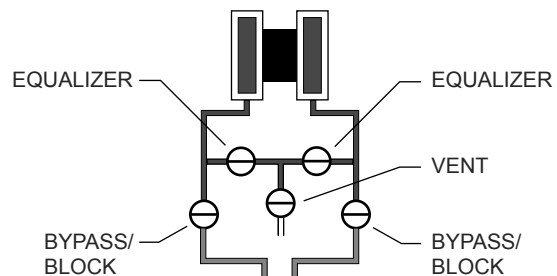

- Repeat steps 3 through 5 to retest the manifold for leaks.

An additional test can verify the condition of the equalizing valves. Assuming the above test has confirmed the system is leak free, close both equalizing valves and open the vent. Monitor the differential pressure reading for any change. Repair or replace the manifold as required if the differential pressure varies.

Zero Offset (Static Pressure or Differential Pressure)

The static pressure input for the Scanner 2000 is zeroed at the factory before shipment. However, changes in temperature and atmospheric pressure can cause the static pressure and differential pressure readings to vary. The inputs can be easily zeroed in the field, if necessary, prior to putting the Scanner 2000 into service.

To zero the static pressure or differential pressure

- Close the bypass valves to isolate the pressure below the manifold.
- Open the equalizer and vent valves.
- Connect to the Scanner 2000 with the ModWorX™ Pro software, and apply zero pressure from the Calibrate Inputs screen (see the ModWorX™ Pro Software User Manual; Part No. 9A-30165025; for complete instructions).

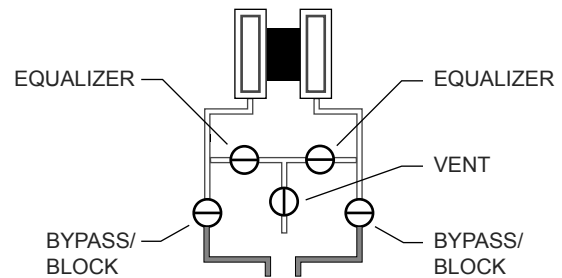

Static Pressure Calibration and Verification

Note The pressure range stamped on the MVT is expressed as psia (absolute). However, Scanner 2000 pressure inputs are recalibrated as psig (gauge) at the factory before the device is shipped. Therefore, pressure readings displayed on the LCD and in the ModWorX Pro software are in terms of psig.

The static pressure and differential pressure inputs are calibrated and verified before the Scanner 2000 leaves the factory, and recalibration in the field may or may not be required. To comply with API standards for verification, “as found” readings should be recorded at approximately 0, 50, and 100 percent of the operating pressure range, increasing, and at 80, 20 and 0 percent of the operating pressure range, decreasing. For example, the static pressure measurements of a 1500-psi sensor should be verified at 0 psi, 750 psi, and 1500 psi, then at 1200 psi, 300 psi, and 0 psi.



WARNING: Do not subject the Scanner 2000 microEFM to unnecessary shock or over-range pressure during maintenance operations.

To calibrate the static pressure

- Close the bypass valves to isolate the pressure below the manifold.
- Open the equalizer valves and vent valve to purge the lines.
- Close the vent valve.
- Connect a static pressure simulator to the manifold (either side).

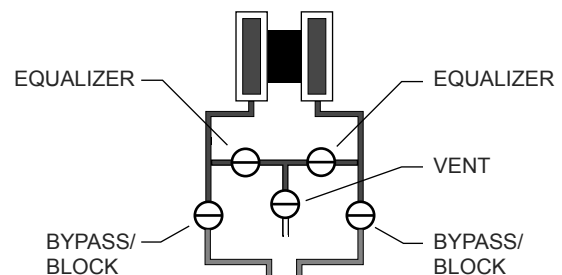

5. Connect to the Scanner 2000 with the ModWorX™ Pro software. Click on the **Calibrate Inputs** menu button and proceed through the calibration per instructions in the ModWorX™ Pro Software User Manual.
6. At the appropriate software prompt, enter a known pressure.
7. Apply the same amount of pressure to the MVT using the simulator (see the ModWorX™ Pro Software User Manual for complete instructions). The ModWorX™ Pro software will display a measured value and a percentage of change.
8. Repeat steps 6 and 7 as necessary to enter multiple calibration points.
9. When all calibration points have been entered, click **Save Changes** to apply the new calibration settings.

To verify the static pressure, perform the steps described in the calibration procedure above, except instead of choosing **Calibrate** from the Change Calibration Task window, choose **Verify**. You will be prompted to enter an applied value, and you will apply the same amount of pressure to the MVT, just as in the calibration process. The ModWorX™ Pro software will display a measured value and a percentage of error. When you click Save Changes, the measured values are written to memory for reference.

Differential Pressure Calibration and Verification

The static pressure and differential pressure inputs are calibrated and verified before the Scanner 2000 leaves the factory, and recalibration in the field may or may not be required. To comply with API standards for verification, “as found” readings should be recorded at approximately 0, 50, and 100 percent of the operating pressure range, increasing, and at 80, 20 and 0 percent of the operating pressure range, decreasing. For example, the differential pressure measurements of a 200-In. H₂O sensor should be verified at 0 In. H₂O, 100 In. H₂O, 200 In. H₂O, then at 160 In. H₂O, 40 In. H₂O, and 0 In. H₂O.



WARNING: Do not subject the Scanner 2000 microEFM to unnecessary shock or over-range pressure during maintenance operations.

To calibrate the differential pressure

1. Close the bypass valves to isolate the pressure below the manifold.
2. Open the equalizer valves and vent valve to purge the lines.
3. Close the high-pressure side equalizer valve.
4. Connect a pressure simulator to the high-pressure side of the manifold.
5. Connect to the Scanner 2000 with the ModWorX™ Pro software. Click on the **Calibrate Inputs** menu button and proceed through the calibration per instructions in the ModWorX™ Pro Software User Manual, Part No. 9A-30165025.
6. At the appropriate software prompt, enter a known pressure.
7. Apply the same amount of pressure to the high side of the MVT using the simulator (see the ModWorX™ Pro Software User Manual, Part No. 9A-30165025, for complete instructions). The ModWorX™ Pro software will display a measured value.

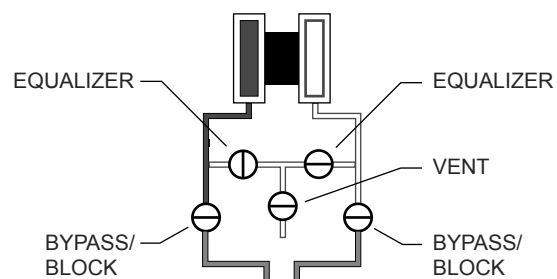

8. Repeat steps 6 and 7 as necessary, to enter multiple calibration points, and apply the new measured values from the ModWorX™ Pro interface.
9. When all calibration points have been entered, click **Save Changes** to apply the new calibration settings.

To verify the differential pressure, perform the steps described in the calibration procedure above, except instead of choosing **Calibrate** from the Change Calibration Task window, choose **Verify**. You will be prompted to enter an applied value, and you will apply the same amount of pressure to the MVT, just as in the calibration process. The ModWorX™ Pro software will display a measured value and a percentage of error. When you click **Save Changes**, the measured values are written to memory for reference.

Placing the Scanner into Operation

To put the Scanner into operation;

1. Close the vent valve.
2. Open the equalizer valves.
3. Open the bypass/block valves to allow pressure to be supplied to both sides of the MVT.
4. Close the equalizer valves.
5. Open the vent valve (optional, some users may choose to leave the vent closed).

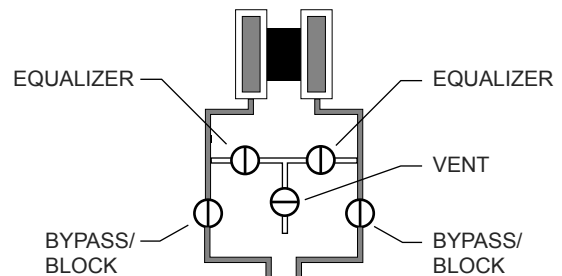

Industry Standard Compliance

To ensure measurement accuracy, flow runs and turbine meter runs must be installed in accordance with industry standards. Table 2.2, page 56, and Table 2.3, page 57, reference the sections in these standards that apply specifically to flow run and hardware installation.

Table 2.4, page 57, references standards that apply to fluid properties for gas, steam, and liquid measurement. Fluid properties used for gas measurement calculations such as compressibility factors and density are in accordance with AGA Report No. 8. For steam measurement, algorithms are based on the IAPWS Industrial-Formulation 1997 (IF-97) standard. For temperature-compensated liquid measurement, fluid property calculations are based on API-2540 - 1980, Petroleum Measurement Tables.

Heating values for gas measurement are calculated in accordance with AGA Report No. 3, Part 3, Appendix F, using the constants defined in GPA 2145.

For more information, see the ModWorX™ Pro Software User Manual, Part No. 9A-30165025.

Table 2.2—Industry Standards for Orifice Meters

Standard	Applicable Section	Description	Notes
AGA Report No. 3: Orifice Metering of Natural Gas and Other Related Hydrocarbon Fluids	Part 2: Specification and Installation Requirements, Section 2.6 (Installation requirements)	Specifications for orifice meters (to include beta ratios) Installation requirements for orifice plates, meter tubes, flow conditioners, and thermometer wells	This standard is also distributed under the following names: API MPMS Chapter 14.3, Part 2; ANSI/API 14.3, Part 2-2000; and GPA 8185, Part 2.
ISO 5167: Measurement of Fluid Flow by Means of Pressure Differential Devices Inserted in Circular Cross-Section Conduits Running Full	Part 1: General Principles and Requirements	Installation of orifice plates inserted into a circular cross-section conduit running full Limitation of pipe size and Reynolds number	ISO 5167 is applicable only to flow that remains subsonic throughout the measuring section and where the fluid can be considered single-phase. It is not applicable to the measurement of pulsating flow. It does not cover the use of orifice plates in pipe sizes less than 50 mm (2 in.) or more than 1000 mm (39 in.), or for pipe Reynolds numbers below 5000.
ISO 5167: Measurement of Fluid Flow by Means of Pressure Differential Devices Inserted in Circular Cross-Section Conduits Running Full	Part 2: Orifice Plates	Specifies orifice plates that can be used with flange pressure tapplings, corner pressure tapplings, D and D/2 pressure tapplings.	
API Manual of Petroleum Measurement Standards, Chapter 21.1 (Electronic Gas Measurement)	Section 1.7 - Equipment Installation	Installation of electronic gas measurement devices and associated communications, gauge/impulse lines, and cabling	
	Section 1.8 - Equipment Calibration and Verification	Requirements for calibrating and verifying the accuracy of electronic gas measurement devices	

Industry Standards for Cone Meters

For installation requirements for use with a cone meter and applicable flow rate calculations, see the NuFlo Cone Meter User Manual, Part No. 9A-85165000.

Table 2.3—Industry Standards for Turbine Meters

Standard	Applicable Section	Description	Notes
AGA Report No. 7: Measurement of Natural Gas by Turbine Meters	Section 7- Installation Specifications	Installation of gas turbine meters to include flow direction, meter orientation, meter run connections, internal surfaces, temperature well location, pressure tap location, and flow conditioning Illustrations of recommended installation configurations Environmental considerations, the use of other devices to improve meter performance, and precautionary measures.	This specification applies to axial-flow turbine flowmeters for measurement of natural gas, typically 2-in. and larger bore diameter, in which the entire gas stream flows through the meter rotor.
API Manual of Petroleum Measurement Standards, Chapter 21.1 (Electronic Gas Measurement)	Section 1.7 - Equipment Installation	Installation of electronic gas measurement devices and associated communications, gauge/impulse lines, and cabling	
	Section 1.8 - Equipment Calibration and Verification	Requirements for calibrating and verifying the accuracy of electronic gas measurement devices	
API Manual of Petroleum Measurement Standards, Chapter 5 (Metering)	Section 3, Measurement of Liquid Hydrocarbons by Turbine Meters	Description of unique installation requirements and performance characteristics of turbine meters in liquid hydrocarbon service	This section does not apply to the measurement of two-phase fluids.

Table 2.4—Industry Standards for Fluid Properties

AGA Report No. 3, "Orifice Metering of Natural Gas and Other Related Hydrocarbon Fluids," Part 3, "Natural Gas Applications," Third Edition, 1992, Appendix F, "Heating Value Calculation," American Gas Association, catalog XQ9210.
GPA 2145-09, "Table of Physical Properties for Hydrocarbons and Other Compounds of Interest to the Natural Gas Industry," Gas Processors Association, Tulsa Oklahoma, 2008.
AGA Report No 8, "Compressibility Factors of Natural Gas and Other Related Hydrocarbon Gases," Second Edition, AGA Catalogue XQ9212, American Gas Association, Arlington Virginia 1994.
W. Wagner and A. Kruse, "Properties of Water and Steam - The Industrial Standard IAPWS-IF97 for the Thermodynamic Properties and Supplementary Equations for Other Properties," Springer-Verlag, Berlin Heidelberg 1998, ISBN 3-540-64339-7.
API-2540, "Petroleum Measurement Tables," American Petroleum Institute, 1980.

Section 3—Wiring the Scanner 2000

Field Wiring Connections



WARNING: To prevent ignition of hazardous atmospheres, do not remove the cover while circuits are alive. The Scanner 2000 poses no hazard when opened in a safe area.

CAUTION All field wiring must conform to the National Electrical Code, NFPA 70, Article 501-4(b) for installations within the United States or the Canadian Electric Code for installations within Canada. Local wiring ordinances may also apply. All field wiring must be rated for temperatures of 90°C or higher, and have a wire range of 22 to 14 AWG. Terminal block screws must be tightened to a minimum torque of 5 to 7 in-lbs. to secure the wiring within the terminal block. Only personnel who are experienced with field wiring should perform these procedures.

To wire the Scanner 2000 for operation, complete the following field connections:

1. Unscrew the cover of the enclosure counter-clockwise until it separates from the main body of the enclosure.
2. Using a small standard blade screwdriver, remove the two #4-40 × 7/8” screws located to the right and left side of the display.
3. Lift the display/keypad assembly from the enclosure, making sure the circuit assembly does not contact the enclosure.
4. Connect the lithium battery to the J1 connector on the circuit assembly. See Figure 3.2, page 61.
5. Connect wiring for external power, if appropriate. See Grounding Procedures, page 60, and see Figure 3.3, page 62 for a wiring diagram.
6. Connect the flowmeter input wiring to terminal block TB2, if appropriate. See Figure 3.4, page 63.
7. Connect the process temperature input wiring to terminal block TB2, if appropriate. See Figure 3.5, page 64.
8. Connect wiring for output signals, if appropriate. See Figure 3.6, page 65, Figure 3.7, page 66, and Figure 3.8, page 67. If the instrument is equipped with an expansion board, connect wiring for expansion board inputs/outputs, if appropriate. See page A-10 for expansion board wiring diagrams.
9. Place the circuit assembly over the standoffs and fasten with the two #4-40 × 7/8” screws, ensuring that all connector wiring is inside the enclosure and in no position where it may be damaged when the enclosure cover is replaced.
10. Recalibrate the Scanner 2000 (if necessary).
11. If external and internal power supplies were removed, reset the clock to ensure that the time stamps in the log data are accurate. The clock can be reset using the instrument keypad or ModWorX™ Pro software.
12. Replace the enclosure cover by threading it onto the enclosure in a clockwise direction.

Grounding Procedures

To power the Scanner 2000 microEFM with an external DC supply, route the ground conductor through a conduit opening in the top of the Scanner 2000 enclosure with the power conductors and connect it to the ground screw inside the enclosure (note the round sticker that marks this location in Figure 3.1).

If national or local electrical codes require the enclosure to be grounded, a protective earth grounding conductor may be required. To install a protective earth ground, connect an earth ground conductor to the stainless ground lug near the top of the Scanner 2000 enclosure (also shown in Figure 3.1) or to the internal ground screw, and connect the other end to a ground rod or other suitable system earth ground. The ground lugs will accept wire sizes from 14 AWG solid conductor to 4 AWG stranded conductor.

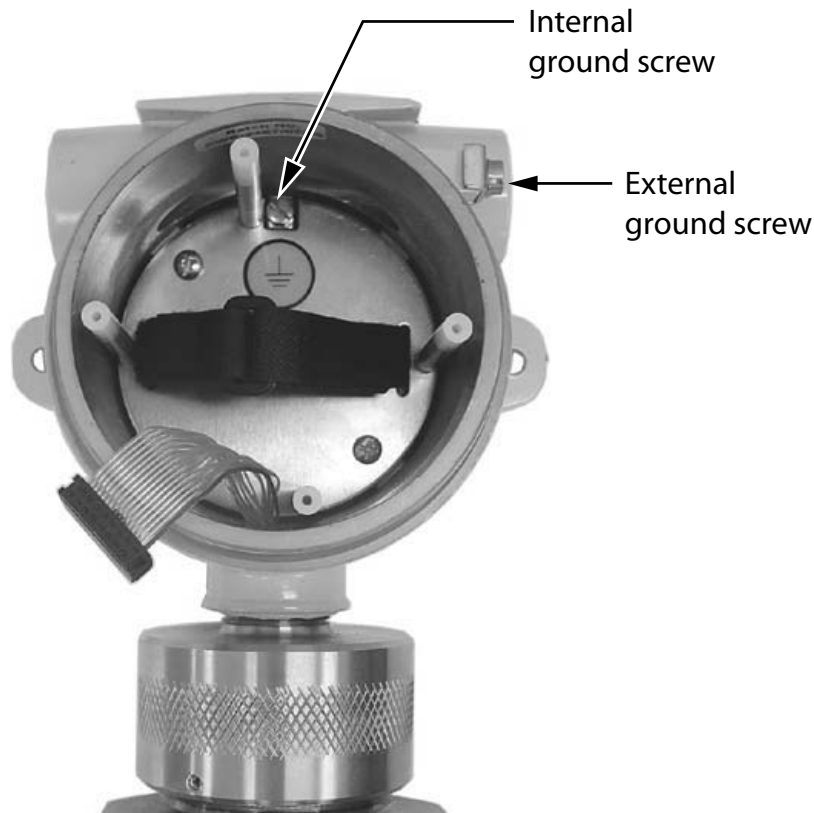

Figure 3.1—Ground screw locations

Power Supply Wiring

Internal Power Supply

The Scanner 2000 microEFM is shipped with a lithium battery pack. To supply power to the instrument, connect the battery cable to connector J1 on the main circuit assembly (Figure 3.2).

Low-power microprocessor technology enables the Scanner 2000 to operate for an estimated 1 year on a lithium battery pack. The lithium battery pack is ideal for use in extreme temperatures, although extreme cold temperatures may reduce battery life.

To maximize battery life,

- operate the Scanner using the following default configuration settings:
 - calculation frequency: 1 minute
 - logging frequency (interval): 1 hour
 - download frequency: monthly
- disconnect the Scanner 2000 from the RS-232 to RS-485 converter when ModWorX Pro software is not in use. When ModWorX Pro is running, the computer powers the converter; when the software is not running, the Scanner 2000 powers the converter, causing a current drain to the Scanner battery.
- avoid the following conditions/activities:
 - operation at extremely cold temperatures
 - use of digital output (pulse or alarm)
 - use of analog input without external power (when expansion board is installed)

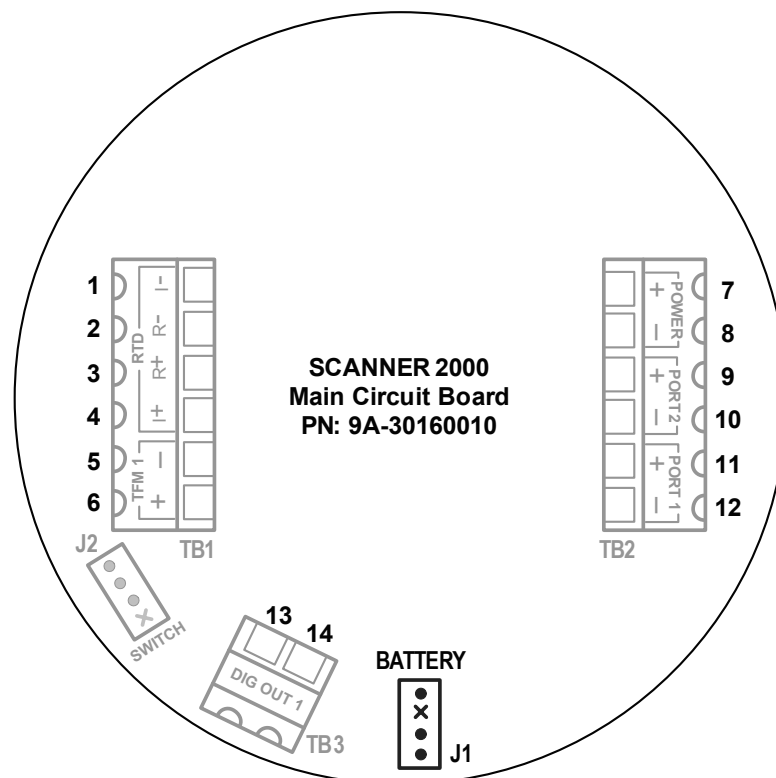

Figure 3.2—Lithium battery pack connection

When an external power supply is used as the primary power source, the lithium battery pack serves as a backup power supply. The use of an alternate power source extends battery life and helps ensure that timekeeping and volume accumulation will not be interrupted during a power failure.

External Power Supply

The Scanner 2000 can be connected to a remote power supply by a two-conductor cable (Figure 3.3). The power supply and cable must be capable of supplying 6 to 30 VDC @ 50 mA.

The external power supply must be an approved SELV source, insulated from the AC main by double/reinforced insulation per CSA C22.2 No.61010-1-04 / UL 61010-1 – 2nd Edition.

Important In all applications using an external power supply, a switch or circuit breaker must be included in the safe area external power supply installation within easy reach of the operator. The switch or circuit breaker must be marked as the “disconnect” for the safe area external DC power supply.

Important If the main circuit board is marked with a revision level of 02 or older (revisions 01, C, B, or A), a zener diode (Part No. 1.5KE33CA) must be installed for CE approval. The zener diode is not required for revision 03 and newer circuit boards.

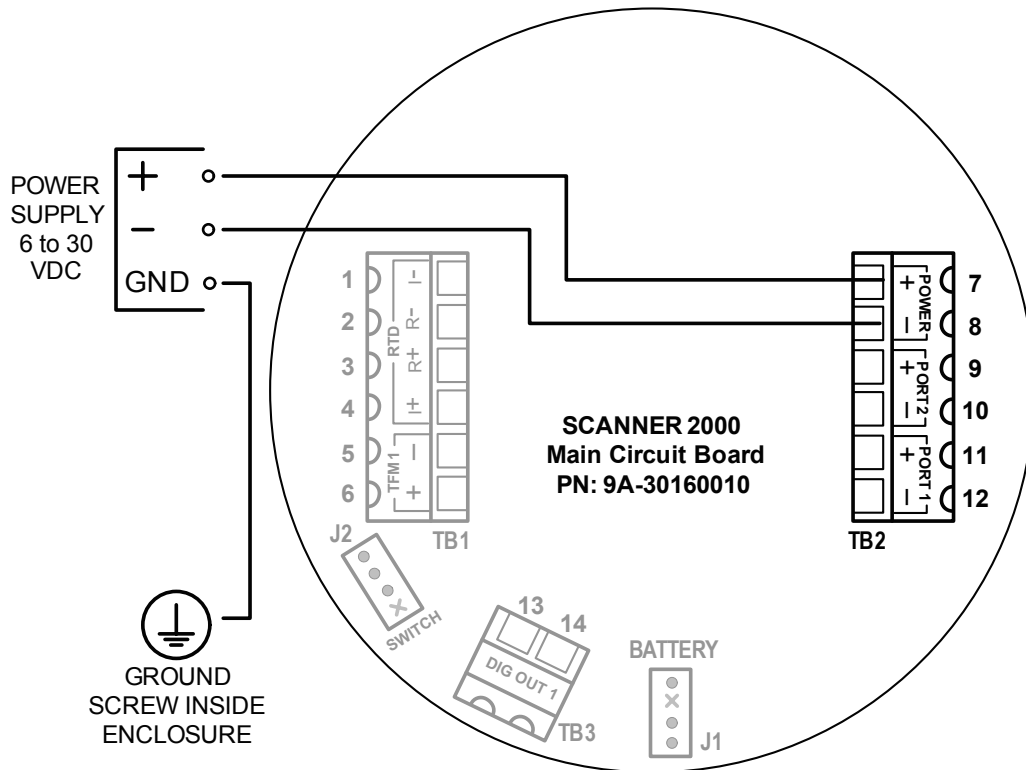

Figure 3.3—External power supply wiring

Input Wiring

Turbine Flowmeter Input

The Turbine Input 1 on the main circuit board provides the turbine flowmeter input signal generated by a magnetic pickup, enabling the Scanner 2000 to calculate and display instantaneous flow rates and accumulated totals. Wire as shown in Figure 3.4.

Note If the expansion board option is installed, a second turbine input is available. See Figure A.17, page A-12, for Turbine Input 2 wiring instructions.

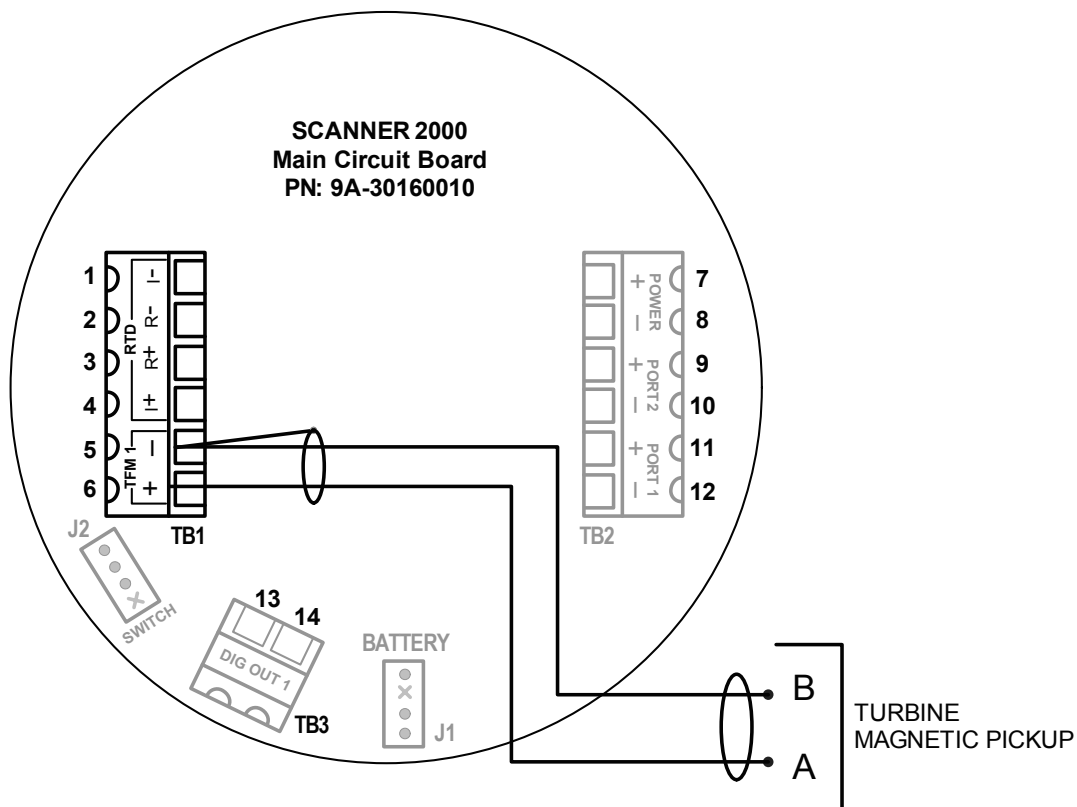

Figure 3.4—Flowmeter input wiring

RTD Input

A 4-wire explosion-proof, 100-ohm platinum 0.00385 OHM/OHM°C RTD rated for Class I, Div. 1, Groups B, C, and D usage is recommended for performing orifice gas and compensated liquid calculations or gas turbine calculations, though a 2- or 3-wire RTD may prove functional. Wire as shown in Figure 3.5.

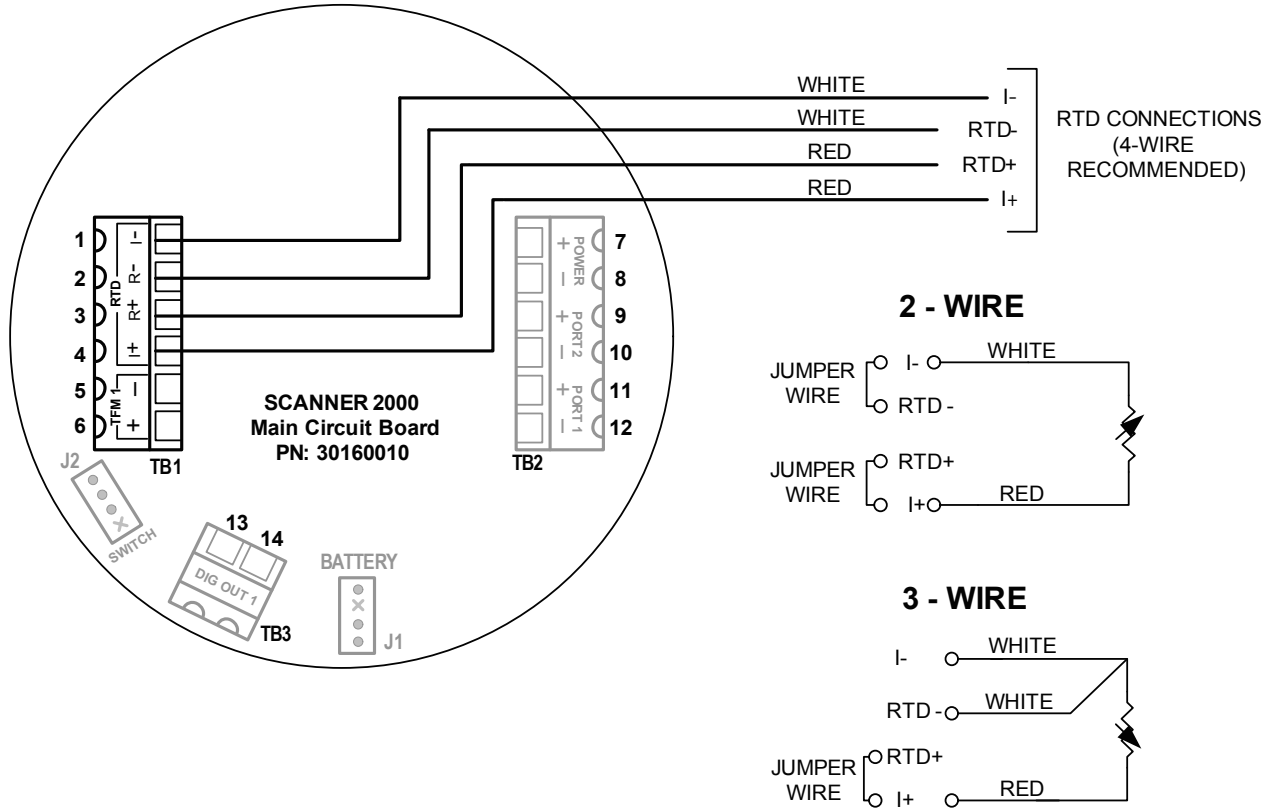

Figure 3.5—Process temperature input wiring

Output Wiring

Digital Output (Pulse or Alarm)

The standard Scanner 2000 supports a solid-state digital output that is configurable as either a pulse output or an alarm output. As a pulse output, the pulse width duration and pulse representation are both configurable. Because the circuit is isolated, it can be used in conjunction with any other feature on the Scanner 2000. A two-conductor cable from the Scanner 2000 to the remote location is required. The maximum rating of the digital output circuit is 60 mA at 30 VDC. Maximum frequency is 50 Hz. Wire as shown in Figure 3.6.

For reduced power consumption, turn the digital output feature off when it is not in use.

Important If the main circuit board is marked with a revision level of 02 or older (revision 01, C, B, or A), a zener diode (Part No. IN4752) must be installed for CE approval. The zener diode is not required for revision 03 and newer circuit boards.

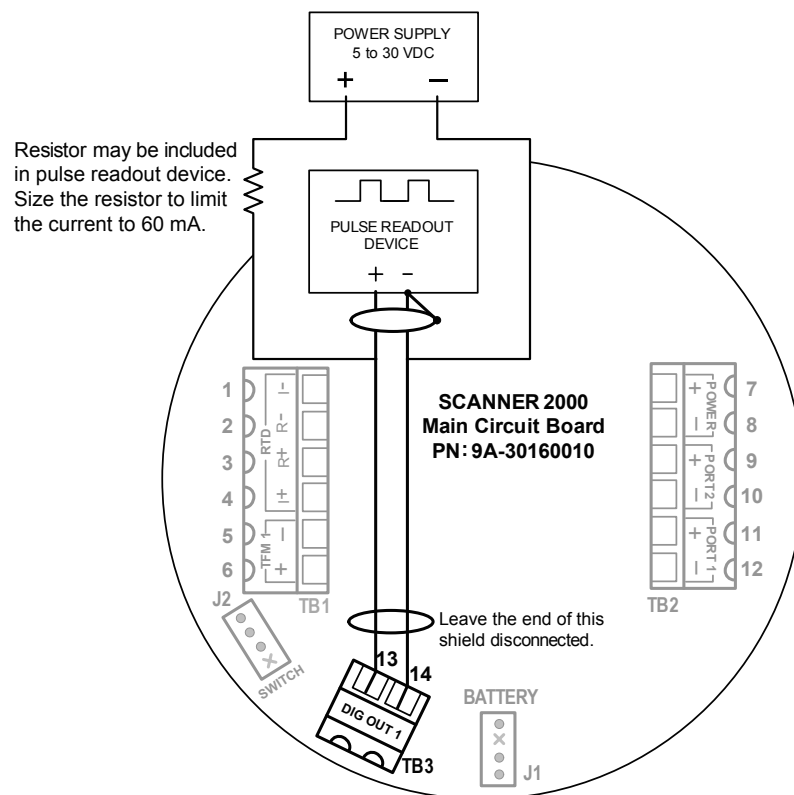

Figure 3.6—Pulse output wiring

RS-485 Output—Permanent Computer Connection

The RS-485 output is required for communication with the interface software. The wiring diagram in Figure 3.7 supports a permanent connection.

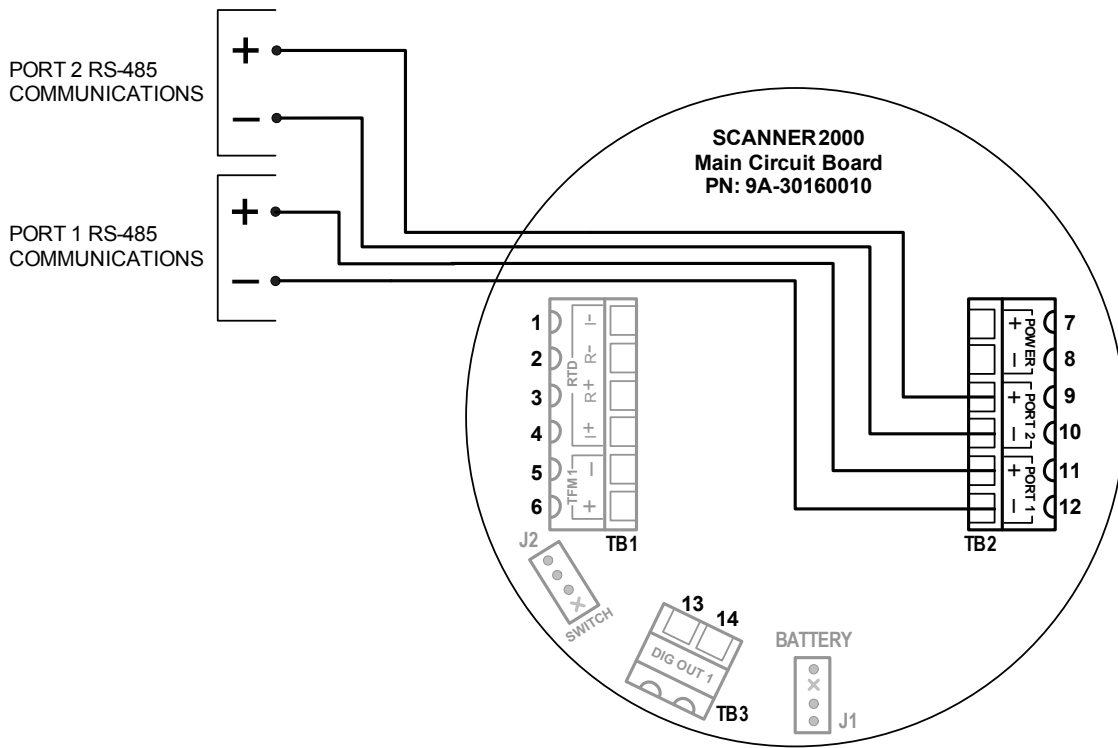

Figure 3.7—RS-485 output (permanent connection)

RS-485 Output—Laptop Computer Connection

The RS-485 output is required for communication with the interface software. The wiring diagram in Figure 3.8 supports a temporary laptop connections using an RS-232 to RS-485 converter.

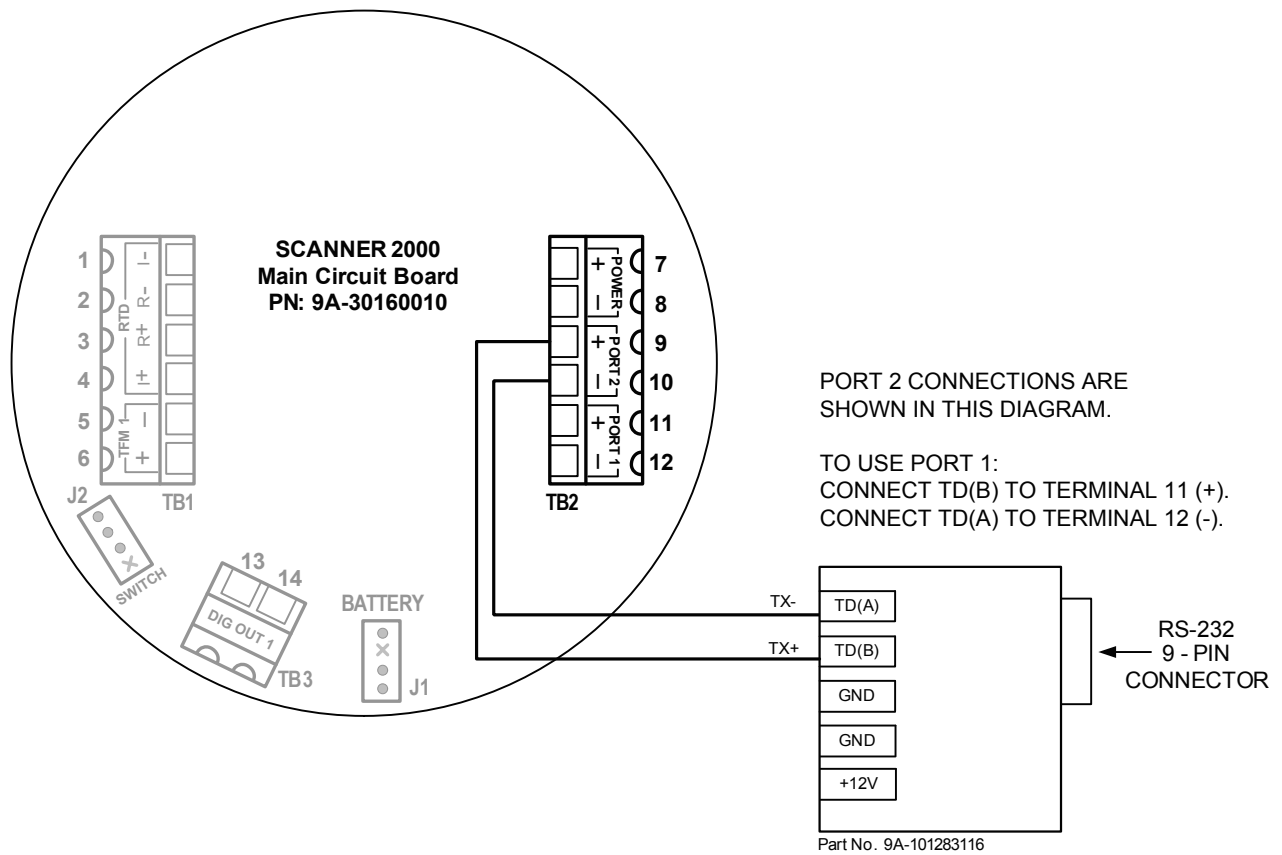

Figure 3.8—RS-485 output (connection to laptop with 9-pin converter)

Configuration via Keypad

Communication parameters such as slave address and baud rate, the date and time, contract hour and plate size can all be configured via the three-button keypad on the front of the instrument. See Section 4—Configuration and Operation via Keypad for step-by-step instructions. All other instrument calibration is performed via the ModWorX™ Pro software.



WARNING: To prevent ignition of hazardous atmospheres, do not remove the cover while circuits are alive. The Scanner 2000 poses no hazard when opened in a safe area.

Configuration via ModWorX™ Pro Software

A laptop connection and the ModWorX™ Pro software provided with the Scanner 2000 are required for the calibration and configuration of the instrument. The Scanner 2000's natural gas and steam calculations typically require configuration of inputs including differential pressure, static pressure, process temperature, and for AGA-7, a turbine meter input.

The Scanner 2000 microEFM supports digital serial communications using EIA-RS-485 hardware with Modicon Modbus® protocol. Either of two Modbus® slave ports facilitates communications with a laptop or PC. The baud rate range for both ports is 300 to 38.4K. Both ports are protected from high-voltage transients.

An RS-232 to RS-485 converter or NuFlo USB adapter is required for connecting the microEFM to a laptop or PC. The converters available from Cameron require no handshaking or external power to operate. See Section 6—Spare Parts for ordering information; see Figure 3.7, page 66, and Figure 3.8, page 67, for wiring instructions.

The NuFlo USB adapter provides an external USB port for connecting to a laptop, and is available as a kit for upgrading any Scanner 2000. See USB Communications Adapter, page A-6 for details; see Section 6—Spare Parts for ordering information.



WARNING: To prevent ignition of hazardous atmospheres, do not remove the cover while circuits are alive. The Scanner 2000 poses no hazard when opened in a safe area.

Section 4—Configuration and Operation via Keypad

The following parameters can be configured using the three-button keypad on the front of the instrument, as shown in Figure 4.1:

- slave address
- baud rate
- date and time
- contract hour
- plate size

All other instrument configuration is performed via the ModWorX™ Pro software.

Because the keypad is protected beneath the lid of the instrument, the enclosure must be opened to access the keypad. For this reason, it is important to configure these settings before installing it in a hazardous area.



WARNING: To prevent ignition of hazardous atmospheres, do not remove the cover while circuits are alive. The Scanner 2000 microEFM poses no hazard when opened in a safe area.

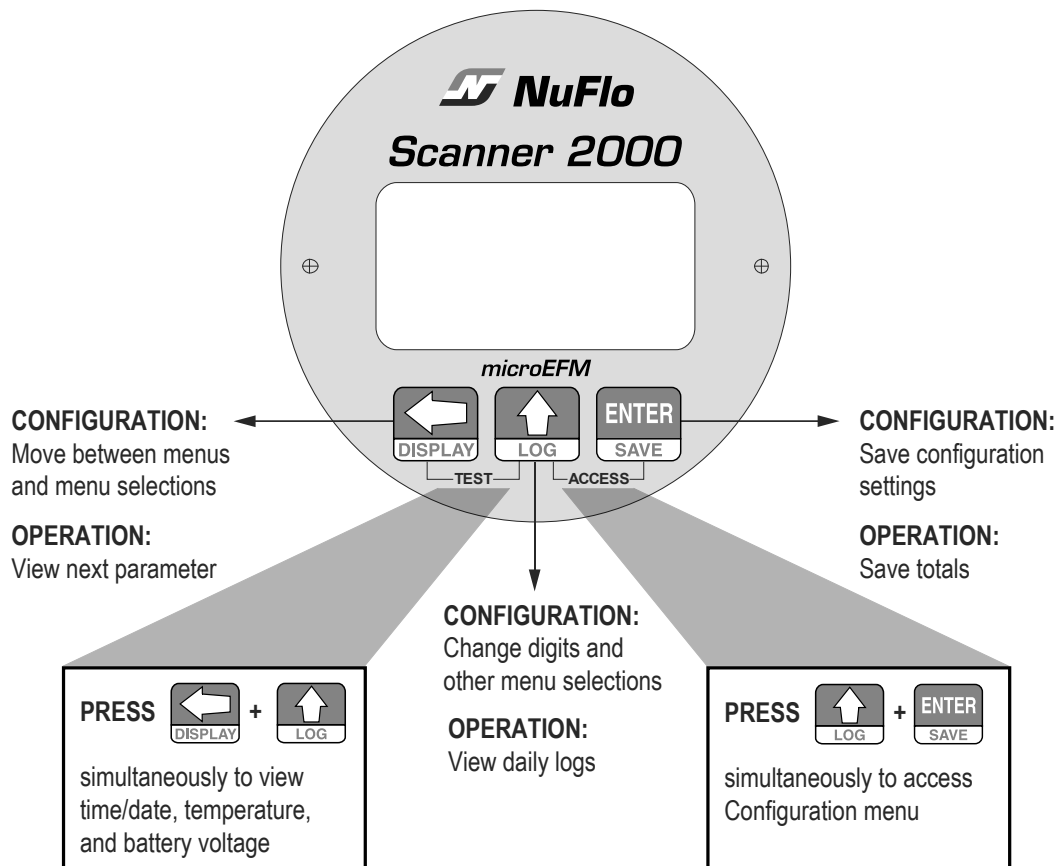
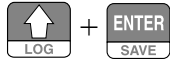





Figure 4.1—Scanner 2000 keypad operation and calibration functions





Entering the Slave Address

The slave address is a setting used in Modbus® communications. It is a number that ranges from 1 to 65535, excluding 252 to 255 and 64764, which are reserved. If the Modbus® request message contains the matching address, the device will respond to the request. In network arrangements, the device must have a unique slave address. For more information about Modbus® communications, refer to Section 1—Introduction. If Modbus® communications are not used, leave the slave address at the factory setting (1).

To Enter a Port 1 Slave Address:

Enter the Access menu.	Press UP ARROW and ENTER simultaneously.	
Locate the Slave Address setting.	PORT 1 SLAVE ADDRESS will appear in the lower display, and the rightmost digit in the top display will begin blinking.	
Enter the Slave Address. (range: 1 to 65535; excluding 252 to 255 and 64764)	Press UP ARROW until the correct digit is displayed.	
	Then press LEFT ARROW to select the next digit to the left.	
	Repeat using UP and LEFT arrows to enter all remaining digits. Press ENTER.	

To Enter a Port 2 Slave Address:







Enter the Access menu.	Press UP ARROW and ENTER simultaneously.	
Locate the Slave Address setting.	Press ENTER twice until PORT 2 SLAVE ADDRESS appears in the lower display. The rightmost digit in the top display will begin blinking.	
Enter the Slave Address. (range: 1 to 65535; excluding 252 to 255 and 64764)	Press UP ARROW until the correct digit is displayed.	
	Then press LEFT ARROW to select the next digit to the left.	
	Repeat using UP and LEFT arrows to enter all remaining digits. Press ENTER.	

The Baud Rate menu prompt will appear immediately following the entry of the slave address. See *Entering the Baud Rate* below for the baud rate entry procedure.







Entering the Baud Rate

The baud rate is the number of bits per second that are on the serial port. This setting must match the setting of the master device polling the Scanner 2000 or the serial port. This only applies to the Modbus® communications; if Modbus® communications are not used, leave the baud rate at the factory setting (9600).

To Enter the Port 1 Baud Rate:

Enter the Access menu.	Press UP ARROW and ENTER simultaneously.	 + 
Locate the Baud Rate setting.	Press ENTER. The words "PORT 1 BAUD RATE" will appear in the lower display.	 
Enter the baud rate.	Press UP ARROW until the correct baud rate is displayed.	
	Press ENTER. "PORT 2 SLAVE ADDRESS" will appear in the bottom display.	

To Enter the Port 2 Baud Rate:

Enter the Access menu.	Press UP ARROW and ENTER simultaneously.	 + 
Locate the Baud Rate setting.	Press ENTER three times. The words "PORT 2 BAUD RATE" will appear in the lower display.	 
Enter the baud rate.	Press UP ARROW until the desired baud rate is displayed.	
	Press ENTER. "EDIT DATE-TIME" will appear in the bottom display.	

Editing the Date and Time

A user can change the date and time from the keypad.









To Edit the Date and Time:

<p>Enter the Access menu.</p>	<p>Press UP ARROW and ENTER simultaneously.</p>	
<p>Locate the Date and Time setting.</p>	<p>Press ENTER four times. The words "EDIT DATE-TIME" will appear in the lower display and the word "no" or "yes" will begin flashing in the top display (default is "no").</p> <p>Press the UP ARROW to change the setting in the top display to "YES."</p> <p>Press ENTER. "DATE MMDDYY" will appear in the bottom display, and the last two digits, representing the year, will begin flashing.</p>	
<p>Enter the month, day and year. The format is MM.DD.YY.</p>	<p>To change the year, press the UP ARROW, repeatedly if necessary, until the last two digits of the year are displayed (for example, for 2006, enter "06").</p> <p>To change the day, press the LEFT ARROW. The two middle digits will begin flashing. Press the UP arrow until the correct day is displayed.</p> <p>Repeat the previous step to select the first two digits and enter the month.</p> <p>Press ENTER. "TIME HHMMSS" will appear in the bottom display, and the last two digits, representing seconds, will begin flashing.</p>	
<p>Enter the time (hour, minute, and seconds). The format is HH.MM.SS.</p>	<p>To change the seconds displayed, press the UP ARROW, repeatedly if necessary, until the correct time (seconds) is displayed.</p> <p>To change the minutes displayed, press the LEFT ARROW. The middle two digits will begin flashing. Press the UP ARROW until the correct time (minutes) is displayed.</p> <p>Repeat the previous step to select the first two digits and enter the hour (military time: Ex. 1 p.m. = 13).</p> <p>Press ENTER. "CONTRACT HOUR" will appear in the bottom display.</p>	

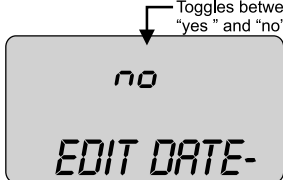
Editing the Contract Hour

A user can set the contract hour from the keypad. The contract hour determines the exact time the daily flow is logged, and is represented by a four-digit number displayed in military time.







To Edit the Contract Hour:

Enter the Access menu.	Press UP ARROW and ENTER simultaneously.	 + 
Locate the Contract Hour setting.	<p>Press ENTER four times. The words "EDIT DATE-TIME" will appear in the lower display and the word "no" or "yes" will begin flashing in the top display (default is "no").</p> <p>Press the UP ARROW to change the setting in the top display to "YES."</p> <p>Press ENTER. "DATE MMDDYY" will appear in the bottom display.</p> <p>Press ENTER a second time. "CONTRACT HOUR" will appear in the bottom display.</p>	    
Enter the contract hour.	<p>Press the UP ARROW, repeatedly if necessary, to change the contract hour. Each press of the button will increment the time by 1 hour.</p> <p>Press ENTER. "SAVING" will appear in the bottom display.</p>	  

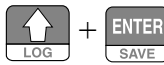
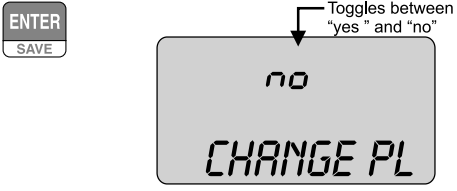
Editing the Plate Size

When the differential pressure producer in a Scanner 2000 installation is an orifice meter and security controls allow, a user can change the size of the orifice plate from the keypad. The plate size is displayed in inches. If “Strict API compliance” is enabled in the Security menu of the ModWorX™ Pro software, this parameter can be configured only from the ModWorX™ Pro interface, which allows the operator to put the instrument into maintenance mode (locked inputs) while the plate change is in process. See Section 3 of the ModWorX™ Pro Software User Manual, Part No. 9A-30165025, for details.

To Edit the Plate Size:

Enter the Access menu.	Press UP ARROW and ENTER simultaneously.	
Locate the Plate Size setting.	Press ENTER five times. The words “CHANGE PLATE” will appear in the lower display and the word “no” or “yes” will begin flashing in the top display (default is “no”).	
	Press the UP ARROW to change the setting in the top display to “YES.”	
	Press ENTER. “PLATE SIZE - INCHES” will appear in the bottom display.	
Enter the new plate size.	Press UP ARROW until the correct digit is displayed.	
	Then press LEFT ARROW to select the next digit to the left.	
	Repeat using UP and LEFT arrows to enter all remaining digits. Press ENTER.	

Section 5—Scanner 2000 Maintenance

The Scanner 2000 is engineered to provide years of dependable service with minimal maintenance. Batteries require periodic replacement, and battery life depends on whether battery power is the primary or secondary power source, the configuration settings of the Scanner 2000, and ambient temperature conditions.

All configuration settings are stored in nonvolatile memory; therefore, configuration settings will not be lost in the event of battery failure.

The circuit assembly or keypad may also require replacement over the life of the instrument. Replacement procedures are provided in this section.



WARNING: Before servicing the Scanner 2000, disconnect all power sources/signal sources or verify that the atmosphere is free of hazardous gases.

Lithium Battery Pack Replacement

The Scanner 2000 uses a lithium battery pack with a typical life expectancy of 1 year. Due to the flat discharge characteristics of the lithium battery, it is difficult to determine how much life remains in a battery at any given time. To preserve configuration and accumulated volume data, replace the battery pack at 1-year intervals.



WARNING: To prevent ignition of hazardous atmospheres, do not remove the cover while circuits are alive. The Scanner 2000 poses no hazard when opened in a safe area.



WARNING: The lithium battery pack that powers the Scanner 2000 is a sealed unit; however, should a lithium battery develop a leak, toxic fumes could escape upon opening the enclosure. Ensure that the instrument is in a well-ventilated area before opening the enclosure to avoid breathing fumes trapped inside the enclosure. Exercise caution in handling and disposing of spent or damaged battery packs. See additional information in Appendix B—Lithium Battery Information.

Important Press the ENTER/SAVE key on the keypad before replacing the lithium battery pack to save accumulated grand totals and previous day totals for flow run and turbine volume, energy, and mass to nonvolatile memory. Once the battery pack is replaced and power is restored to the unit, the last saved accumulated totals will be displayed in the LCD. The instrument clock will need to be reset following battery replacement. All configuration and calibration settings are automatically saved to non-volatile memory and are not affected by a temporary loss of battery power.

The lithium battery pack is secured inside the enclosure by a velcro strap and connected to a connector (J1) near the top of the circuit assembly.

To replace a lithium battery pack in the Scanner 2000, perform the following steps:

1. Unscrew the cover of the enclosure counter-clockwise until it separates from the main body of the enclosure.
2. Using a small standard blade screwdriver, remove the two #4-40 × 7/8" screws located to the right and left side of the display (Figure 5.1, page 76).

3. Lift the display/keypad assembly from the enclosure, making sure the circuit assembly does not contact the enclosure.
4. Loosen the velcro strap, disconnect the battery from the J1 connector on the circuit assembly, and remove the spent battery pack from the enclosure (Figure 5.1).

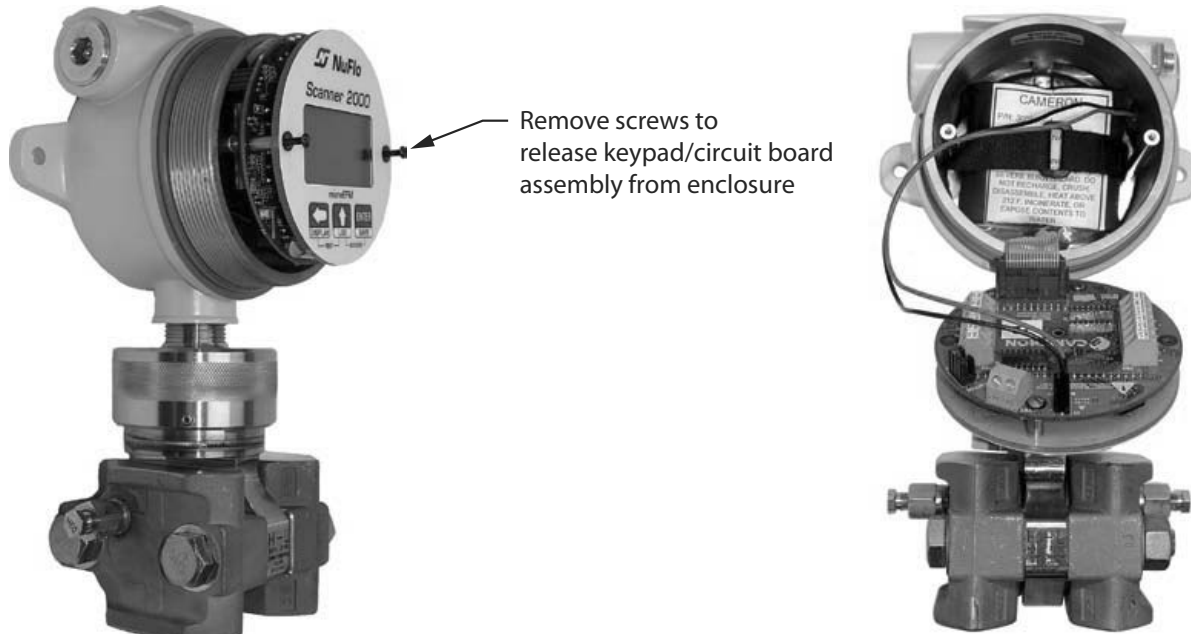

Figure 5.1—Removal of the battery pack from the enclosure

5. Install the new battery pack in the enclosure in the same position as the original battery pack, and secure the Velcro tightly around it.
6. Connect the replacement battery pack to the J1 connector.
7. Place the circuit assembly over the standoffs and fasten with the two #4-40 × 7/8” screws, ensuring that all connector wiring is inside the enclosure.
8. Replace the enclosure cover, threading it onto the enclosure in a clockwise direction.

Important An interruption of power to the Scanner 2000 will cause the internal clock time to be incorrect. Reset the time using the keypad on the switchplate or the ModWorX™ Pro software. See *Editing the Date and Time*, page 72, for details.

Circuit Assembly Replacement



WARNING: To prevent ignition of hazardous atmospheres, do not remove the cover while circuits are alive. The Scanner 2000 poses no hazard when opened in a safe area.

Important Static electricity can damage a circuit board. Handle new boards only by their edges, and use proper anti-static techniques (such as wearing anti-static wrist strap or touching metal to establish an earth ground) prior to handling a board.

Important If possible, download the configuration settings and all archive logs before replacing the circuit board. Press the ENTER/SAVE key on the keypad before disconnecting the battery to save accumulated flow run and turbine volume totals (grand total and current day total), and energy and mass totals to memory.

To replace the circuit assembly, perform the following steps:

1. Unscrew the cover of the enclosure counter-clockwise until it separates from the main body of the enclosure.
2. Using a small standard blade screwdriver, remove the two #4-40 × 7/8" screws located to the right and left side of the display (Figure 5.1, page 76).
3. Lift the display/keypad assembly from the enclosure.
4. Record the locations of all cable connections to the circuit board.
5. Using a small standard blade screwdriver, remove all wiring from terminal blocks TB1, TB2, and TB3, and J2, ensuring that all wiring that is connected to powered circuits is insulated with tape.
6. Unplug the battery cable from connector J1 on the circuit board.
7. Disconnect the sensor ribbon cable from the J5 connector on the circuit board as follows:
 - a. Lift the latch from the black clip securing the ribbon cable (Figure 5.2).
 - b. When the latch is fully open, the ribbon cable will release freely.

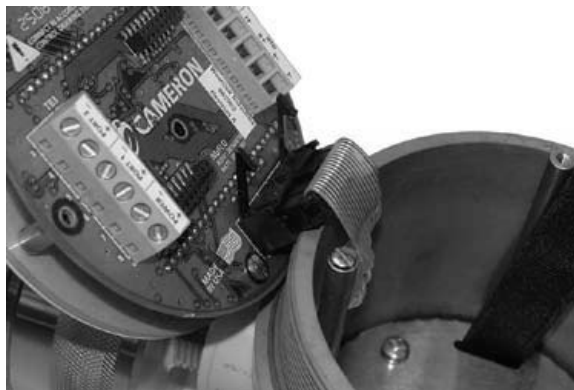

Figure 5.2—Latch securing the ribbon cable

8. Remove the original circuit board/keypad assembly from the enclosure.
9. Remove the two #4-40 × 5/16" screws fastening the circuit board to the keypad (Figure 5.3, page 78).
10. Remove the keypad ribbon cable from the J7 connector on the LCD side of the circuit board by pressing in on the sides of the black plastic clip and pulling gently on the clip. Do not pull on the ribbon cable; the cable will release freely when the clip opens (Figure 5.4, page 78).
11. Remove the circuit board from the enclosure and remove the replacement circuit board from its packaging.
12. Connect the keypad ribbon cable to the J7 connector on the LCD side of the new circuit board by sliding the end of the ribbon into the black clip as far as it will go and pressing the black plastic clip into the connector until it snaps.

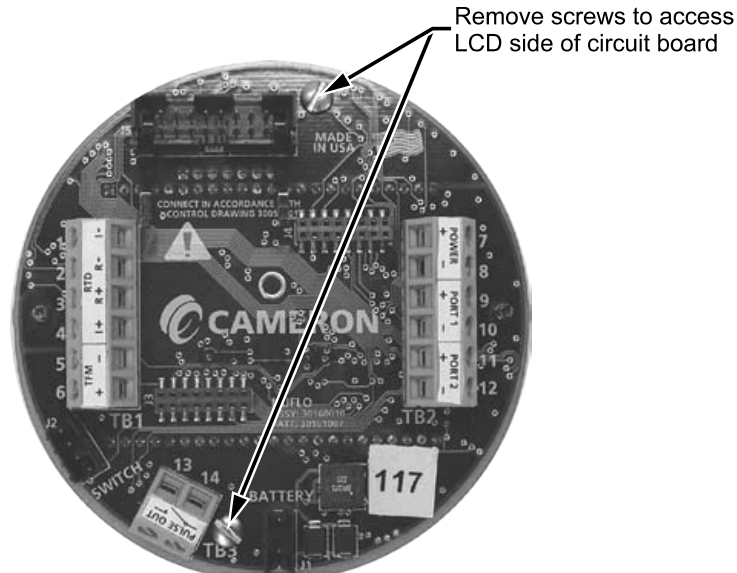

Figure 5.3—Disassembly of circuit board/keypad assembly

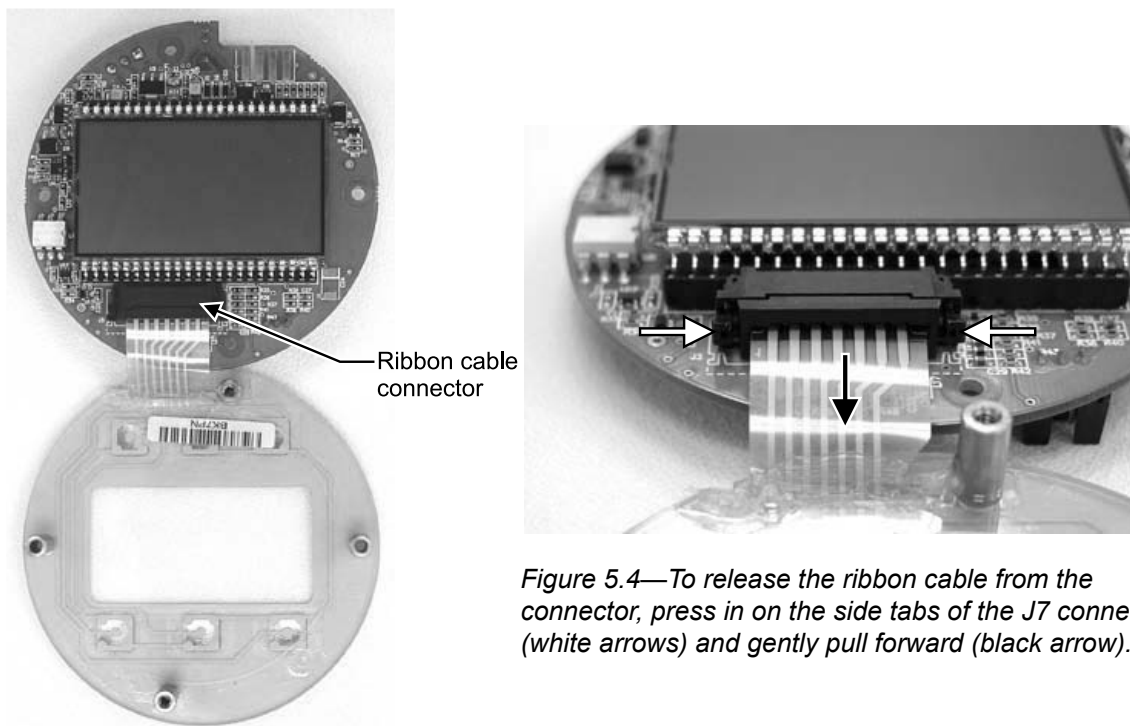

Figure 5.4—To release the ribbon cable from the connector, press in on the side tabs of the J7 connector (white arrows) and gently pull forward (black arrow).

13. Connect the circuit board to the keypad with the two #4-40 × 5/16” screws removed in step 9.
14. Reconnect the sensor ribbon cable to the J5 connector at the top of the circuit board, by inserting the ribbon cable into the black clip and securing the latch on the clip to hold it tightly in place.
15. Reconnect the battery cable to connector J1 on the circuit board.
16. Reconnect all wiring to terminal blocks TB1, TB2 and TB3 (and J2, if applicable).
17. Reattach the display/keypad assembly to the standoffs inside the enclosure with the two #4-40 × 7/8” screws removed in step 2.

18. Recalibrate the Scanner 2000 and replace the enclosure cover.

Important Do not overlook the need to recalibrate the Scanner 2000. Boards that are shipped independently of a Scanner 2000 are not calibrated to compensate for atmospheric pressure; therefore, a Scanner 2000 will not display accurate pressure readings until it is recalibrated.

19. Re-establish power to the peripheral circuitry.

Keypad Replacement



WARNING: To prevent ignition of hazardous atmospheres, do not remove the cover while circuits are alive. The Scanner 2000 poses no hazard when opened in a safe area.

To replace the keypad of the Scanner 2000, perform the following steps:

1. Unscrew the cover of the enclosure counter-clockwise until it separates from the main body of the enclosure.
2. Using a small standard blade screwdriver, remove the two #4-40 × 7/8" screws located to the right and left side of the display (Figure 5.1, page 76).
3. Lift the display/keypad assembly from the enclosure.
4. Remove the two #4-40 × 5/16" screws fastening the circuit assembly to the keypad (Figure 5.3, page 78).
5. Disconnect the keypad ribbon cable from the J7 connector on the LCD side of the circuit assembly as follows:
 - a. Grasp the black clip between a thumb and forefinger (Figure 5.4, page 78).
 - b. Squeeze both sides of the clip and gently pull to release the clip from the plastic connector that holds it in place. DO NOT PULL on the ribbon cable. When the black plastic clip is properly disengaged, the cable will release freely.
6. Remove the old keypad.
7. Connect the ribbon cable of the replacement keypad to the J7 connector on the LCD side of the circuit assembly as follows:
 - a. Insert the end of the ribbon cable into the plastic clip.
 - b. While holding the ribbon cable in place, press the black plastic clip into the connector until it snaps.
8. Mount the circuit assembly to the keypad with the two #4-40 × 5/16" screws removed in step 4.
9. Mount the display/keypad assembly to the enclosure with the two #4-40 × 7/8" screws removed in step 2.
10. Recalibrate the Scanner 2000 if necessary.
11. Replace the enclosure cover and tighten.

MVT Replacement

Important Press the ENTER/SAVE key on the keypad before disconnecting the battery to save accumulated flow run and turbine volume totals (grand total and current day total), and energy and mass totals to memory.

To replace the MVT of the Scanner 2000, perform the following steps:

1. Unscrew the cover of the enclosure counter-clockwise until it separates from the main body of the enclosure.
2. Using a small standard blade screwdriver, remove the two #4-40 × 7/8" screws located to the right and leftside of the display (Figure 5.1, page 76).
3. Lift the display/keypad assembly from the enclosure.
4. Unplug the battery cable from connector J1 on the circuit board.
5. Disconnect the sensor ribbon cable from the J5 connector on the circuit board as follows:
 - a. Lift the latch from the black clip securing the ribbon cable (Figure 5.2, page 77).
 - b. When the latch is fully open, the ribbon cable will release freely.
6. Loosen the set screw in the side of the MVT adapter.
7. Rotate the adapter counterclockwise to break the connection with the MVT sensor body.
8. Detach the MVT sensor from the adapter, pulling the ribbon cable free.
9. Remove the replacement MVT from its packaging and route the ribbon cable through the adapter and up into the Scanner 2000 enclosure.
10. Screw the MVT into the adapter until it meets with resistance.
11. Slowly unscrew the MVT sensor until the vents on the sides of the MVT are oriented to the back of the enclosure.
12. Replace the set screw in the adapter and tighten.
13. Connect the ribbon cable from the sensor to the MVT connector (J5) on the main circuit board.
14. Reconnect the battery cable to connector J1 on the main board.
15. Reinstall the display/keypad assembly in the enclosure, using the screws that were removed in step 2.
16. Recalibrate the Scanner 2000 and replace the cover on the enclosure.

Important Do not overlook the need to recalibrate the Scanner 2000. MVTs that are shipped independently of a Scanner 2000 are not calibrated to compensate for atmospheric pressure; therefore, a Scanner 2000 will not display accurate pressure readings until it is recalibrated.

Section 6—Spare Parts



WARNING: EXPLOSION HAZARD – Substitution of components may impair suitability for Class I, Division 1. Use of spare parts other than those identified by Cameron International Corporation voids hazardous area certification. Cameron bears no legal responsibility for the performance of a product that has been serviced or repaired with parts that are not authorized by Cameron.

Table 6.1—Scanner 2000 microEFM Spare Parts

Qty.	Part Number	Description
1	9A-30160010	Circuit Assembly, CPU Board
1	9A-30188004	Kit, Scanner 2000 Expansion Board (TFM Input, Pulse Input, Dual Analog Input, Analog Output, 256 KB Memory) and Quick Start Guide
1	9A-30166005	Assembly, Switchplate
1	9A-21-XX-YY (see Table 6.3)	Assembly, RTD and Cable, Explosion-Proof, Model 21 (XX=cable length, YY=probe length) Available cable lengths: 5, 10, 30, or 50 ft Available probe lengths: 6 in., 12 in., other (custom)
1	9A-100002605	Desiccant, Humidisorb, Self Regenerate, 2 in. x 2 in. Packet with Adhesive
1	9A-30099004	Battery Pack, 2 “D” Batteries in Series, 7.2V, Lithium, with Current Limiting Resistor and Diode (CSA)
1	9A-30099005	Battery Pack, 2 “A” Batteries in Series, 7.2V, Lithium, with Current Limiting Resistor and Diode (for backup power only in an externally powered device) (CSA)
1	9A-0112-9015T	RS-232 to RS-485 Converter, Serial Port Powered, DB9 Connector on Both Ends
1	9A-101283116	RS-232 to RS-485 Converter, Serial Port Powered, DB9 Connector on PC End, Open Terminals on Instrument End
1	9A-30054001	Assembly, External Explosion-Proof Switch, with Extension, Fits ¾ in. Female Pipe Thread (CSA)
1	9A-90017004	Cable Assembly, ¾ in. NPT Explosion-Proof Union, 2-Pin Connector, 10 in., for External RS-485 Communications (CSA)
1	2295634-01	Kit, NuFlo USB Adapter, Installation CD
1	2295524-01	NuFlo USB Adapter, ¾ in. NPT, Explosion-proof Union, 2-Conductor Wire, 12-in.
1	9A-99177001	Adapter, 1 in. Female Pipe to ¾ in. Male Pipe, Plated Steel
1	9A-99177004	Adapter, 1 in. Female Pipe to ¾ in. Male Pipe, Brass
1	9A-99177005	Adapter, 1 in. Female Pipe to ¾ in. Male Pipe, 316 Stainless Steel
1	9A-99177006	Adapter, 1 in. Female Pipe to ¾ in. Male Pipe, ATEX Flameproof, Group IIC, Plated Steel

Table 6.1—Scanner 2000 microEFM Spare Parts

1	9A-99187001	Union, 1 in. NPT, ATEX Flameproof, Zone 1, Group IIB
1	9A-100017622	Union, 1 in., Explosion-Proof, Plated Steel
1	9A-99187003	Union, 1 in., Explosion-Proof, Brass
1	9A-99187004	Union, 1 in., Explosion-Proof, 316 Stainless Steel
1	9A-90017002	Cable Assembly, 2 Pin Molded Connector, 18 inches long
1	9A-99064006	Pipe Plug, Explosion-Proof, ¾-14 NPT, Hex Socket, Brass
1	9A-99064008	Pipe Plug, Explosion-Proof, ¾-14 NPT, Hex Socket, 316 Stainless Steel
1	9A-99189002	O-Ring, 97mm x 3.5mm, XD-I, for Explosion-Proof Enclosure
1	9A-99002019	Screw, Set, #8-32 X 3/16, Hex Socket, Stainless
1	9A-100025380	Screw, Pan Head, Slotted, #4-40 X 7/8 Steel Black Oxide
1	9A-100025381	Washer, Flat, #4 Steel Black Oxide
1	9A-30028004	Kit, Pole Mount, Plated Steel
1	9A-30028005	Kit, Pole Mount, Stainless Steel
1	2295583-01	Kit, Sealing, Measurement Canada
1	9A-30165024	Manual, User, Quick Start
1	9A-30165026	Manual, User, Expansion Board Quick Start
1	9A-30074033	Assembly, Installation Software CD and CD Pocket Folder, ModWorX™ Pro
	See Table 6.4	Multi-Variable Transmitter (selection based on pressure requirements)

Table 6.2—Scanner 2000 microEFM Spare Parts (ATEX-Approved)

1	9A-30099006	Battery Pack, 2 “D” Batteries in Series, 7.2V, Lithium, with Current Limiting Resistor and Diode
1	9A-30099007	Battery Pack, 2 “A” Batteries in Series, 7.2V, Lithium, with Current Limiting Resistor and Diode (for backup power only in an externally powered device)
1	9A-30188004	Kit, Scanner 2000 Expansion Board (TFM Input, Pulse Input, Dual Analog Input, Analog Output, 256 KB Memory) and Quick Start Guide
1	9A-30054002	Assembly, External Explosion-Proof Switch, with Extension, Fits ¾ in. Female Pipe Thread
1	9A-90017008	Cable Assembly, ¾ in. NPT Explosion-Proof Brass Union, 2-Pin Connector, 10 in., for External RS-485 Communications
1	9A-30025002	Tube, Standoff, Stainless Steel, 1.18 in. Hex X 5.98 in. long with ¾ in. NPT Male & Female Ends
1	9A-30025003	Tube, Standoff, Stainless Steel, 1.18 in. Hex X 9.00 in. long with ¾ in. NPT Male & Female Ends
1	9A-30025004	Tube, Standoff, Stainless Steel, 1.18 in. Hex X 12.00 in. long with ¾ in. NPT Male & Female Ends
1	9A-30025005	Tube, Standoff, Stainless Steel, 1.18 in. Hex X 18.00 in. long with ¾ in. NPT Male & Female Ends

Table 6.3—Explosion-Proof RTD and Cable Assemblies (CSA-Approved)

Select one based on specific application.

Qty.	Part No.	Description
1	9A-21-05-06	Model 21 RTD, 5-ft Cable, 6-in. Probe
1	9A-21-05-12	Model 21 RTD, 5-ft Cable, 12-in. Probe
1	9A-21-10-06	Model 21 RTD, 10-ft Cable, 6-in. Probe
1	9A-21-10-12	Model 21 RTD, 10-ft Cable, 12-in. Probe
1	9A-21-30-06	Model 21 RTD, 30-ft Cable, 6-in. Probe
1	9A-21-30-12	Model 21 RTD, 30-ft Cable, 12-in. Probe
1	9A-21-50-06	Model 21 RTD, 50-ft Cable, 6-in. Probe
1	9A-21-50-12	Model 21 RTD, 50-ft Cable, 12-in. Probe

Table 6.4—Multi-Variable Transmitters

Select one based on specific application. The MVTs listed below have bottom ports. Side port models are available on request.

Qty.	Part No. (non-NACE)	Part No. (NACE)	Part No. (Stainless Bolts)	Description
1	9A-99168041	9A-99168046	9A-99168097	100 PSIA, 30 IN H2O
1	9A-99168042	9A-99168047	9A-99168098	300 PSIA, 200 IN H2O
1	9A-99168075	9A-99168086	9A-99168099	300 PSIA, 840 IN H2O
1	9A-99168076	9A-99168087	9A-99168100	500 PSIA, 200 IN H2O
1	9A-99168043	9A-99168048	9A-99168101	1500 PSIA, 200 IN H2O
1	9A-99168077	9A-99168088	9A-99168102	1500 PSIA, 300 IN H2O
1	9A-99168078	9A-99168089	9A-99168103	1500 PSIA, 400 IN H2O
1	9A-99168079	9A-99168090	9A-99168104	1500 PSIA, 840 IN H2O
1	9A-99168044	9A-99168049	9A-99168105	3000 PSIA, 200 IN H2O
1	9A-99168080	9A-99168091	9A-99168106	3000 PSIA, 300 IN H2O
1	9A-99168081	9A-99168092	9A-99168107	3000 PSIA, 400 IN H2O
1	9A-99168082	9A-99168093	9A-99168108	3000 PSIA, 840 IN H2O
1	9A-99168045	9A-99168050	—	5300 PSIA, 200 IN H2O
1	9A-99168083	9A-99168094	—	5300 PSIA, 300 IN H2O
1	9A-99168084	9A-99168095	—	5300 PSIA, 400 IN H2O
1	9A-99168085	9A-99168096	—	5300 PSIA, 840 IN H2O

Appendix A—Scanner 2000 Hardware Options

Explosion-Proof Control Switch

An alternative to the automatic scroll display of parameters on the LCD, an external explosion-proof control switch (Figure A.1) allows the user to manually select which parameter is displayed on the LCD and view daily logs instantaneously without removing the instrument cover or connecting the instrument to a laptop computer.



Figure A.1—Explosion-proof control switch

The switch mounts in either threaded conduit opening in the instrument housing. If both network communications and an RTD are required, a small junction box must be installed to establish a third conduit connection location.

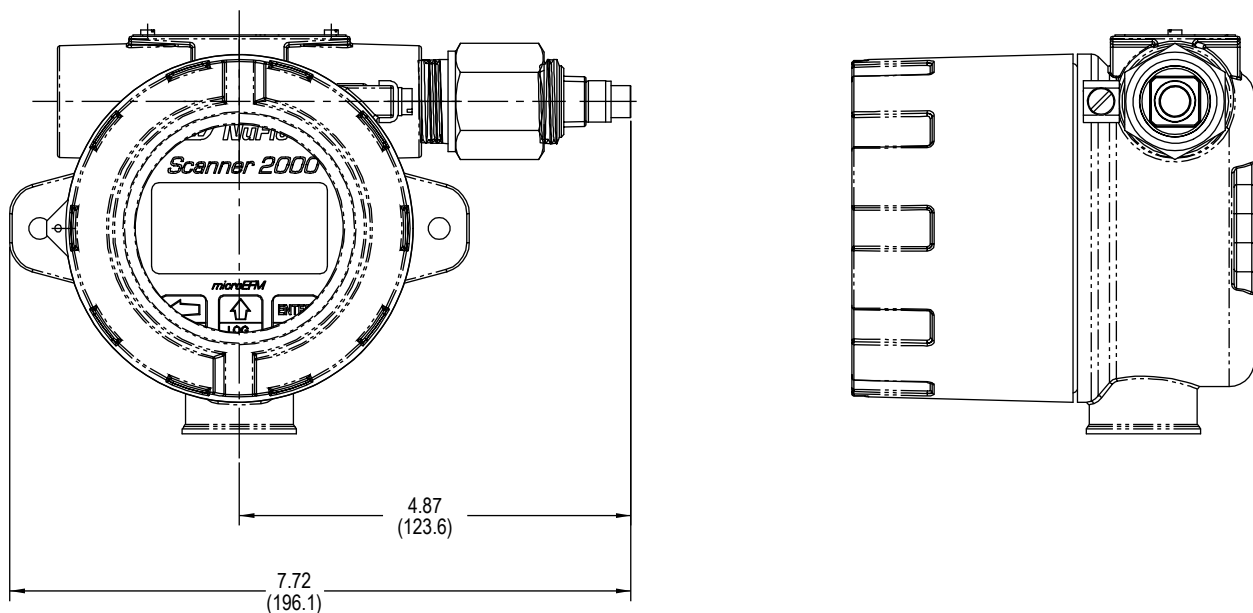

Figure A.2—Dimensions of explosion-proof control switch; inches (mm)

If the switch is ordered with a Scanner 2000 microEFM, it will be installed prior to shipment. To add a switch to an existing Scanner 2000, terminate the leads to connector J2 on the main circuit board (Figure A.3).

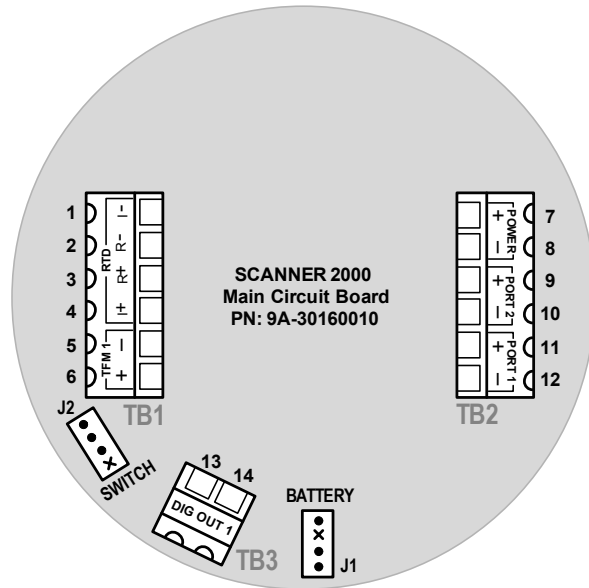

Figure A.3—Wiring of explosion-proof control switch

To select a display parameter for viewing, press and release the push-button switch. With each subsequent press of the switch, the LCD will display a new parameter (Figure A.4). Parameters will appear in the order specified by the user when he configured the display. If the user does not press the button to manually advance to the next parameter, each parameter will be displayed for 30 seconds before the LCD resumes its automatic scroll.

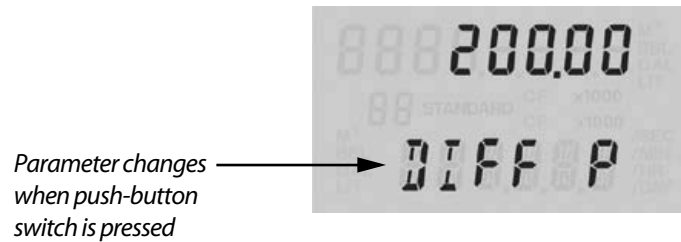

Figure A.4—LCD display of real-time measurements

To access daily logs, press and hold the push-button switch for approximately 4 seconds. In the daily log viewing mode, the LCD will display the daily volume recorded (at the top), the date stamp (bottom), and a two-digit index that indicates the number of days since the log was created (Figure A.5). When you enter this mode, the LCD automatically displays the daily log value from the previous day, which is marked by an index value of “01.”

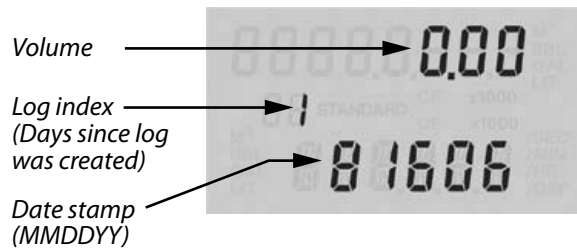

Figure A.5—LCD display of daily logs

To view logs recorded prior to this date, press the push-button switch repeatedly. The index number will increase in value (02, 03, etc.) as the logs progress back in time, and the corresponding daily log volumes and dates will appear on the LCD. The log display will remain in view for 30 seconds before the LCD resumes its automatic scroll of display parameters.

Explosion-Proof RTD Assembly

The Barton Model 21 RTD, shown in Figure A.6 is a 4-wire, 100-ohm explosion-proof RTD assembly that can be connected to the Scanner 2000 enclosure without conduit. Factory-sealed, armored leads are covered in PVC. The RTD assembly can be ordered with tech cable lengths of 5, 10, 30, or 50 ft, and is available with a 6-in. or 12-in. RTD probe. Cable length and probe length are specified in the model part number: 9A-21-XX-YY where XX is the cable length and YY is the probe length.

The Model 21 RTD is CSA-certified for use in Class I Groups B, C, and D and Class II, Groups E, F and G; and Class III hazardous area environments.

Each RTD assembly is fitted with 1/2-in. and 3/4-in. connectors for adapting to various size conduit openings and threadolts. The RTD is field-adjustable for insertion lengths of up to 12 in. For wiring instructions, see Figure 3.5, page 64.

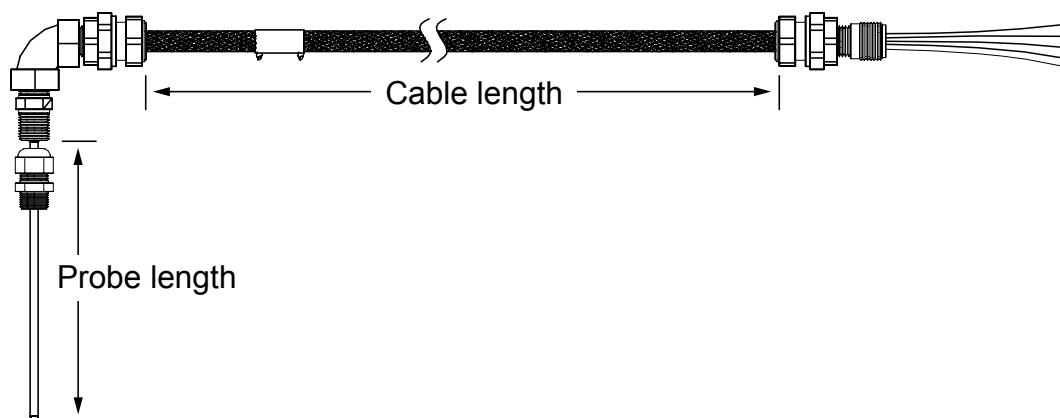

Figure A.6—Explosion-proof RTD assembly

Explosion-Proof Communications Adapter

The explosion-proof communications adapter (Figure A.7, page A-4) provides an RS-485 connection for connecting a laptop or PC to the instrument without removing the instrument cover. When the adapter is ordered with a Scanner 2000, it is factory installed. It may be relocated to either conduit opening in the instrument housing.

An RS-232 to RS-485 converter cable (available from Cameron's Measurement Systems Division) is required for connecting the adapter to a laptop computer. A variety of converter cable options are listed in the Spare Parts list of this manual (see page 81).

The adapter is shipped pre-assembled in the Scanner 2000 when it is ordered with the unit. The installed adapter is comprised of an RS-485 adapter socket, a blanking plug, and a union nut. A plug connector that mates with the RS-485 adapter socket when the adapter is in use is shipped with the device (uninstalled). This plug connector should be wired to an RS-485 converter cable, and stored with the cable when the COM adapter is not in use. Wiring instructions for connecting the plug connector to an RS-485 converter cable are provided in Figure A.9, page A-5.

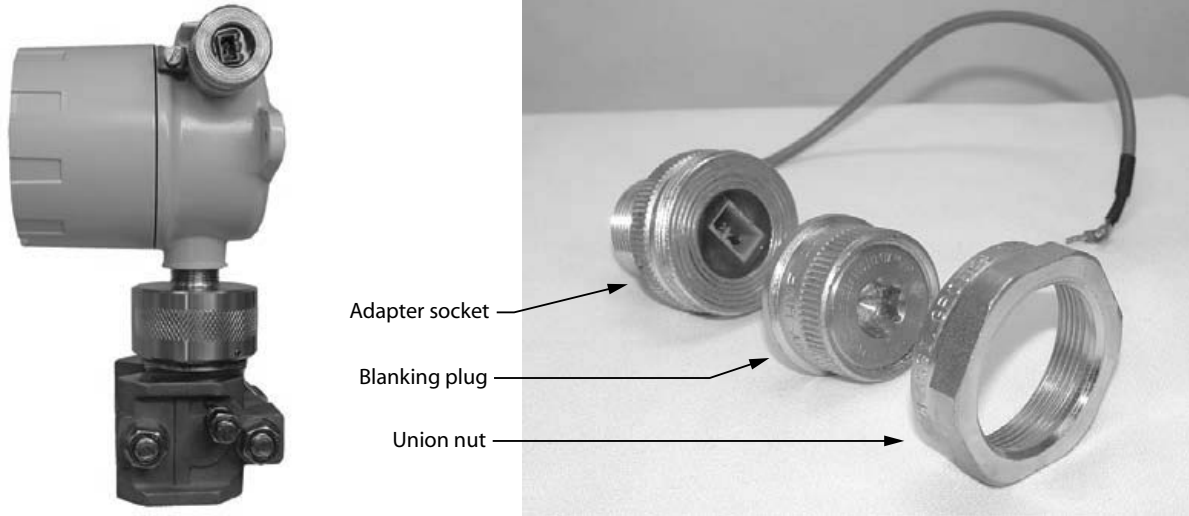

Figure A.7—Explosion-proof communications adapter

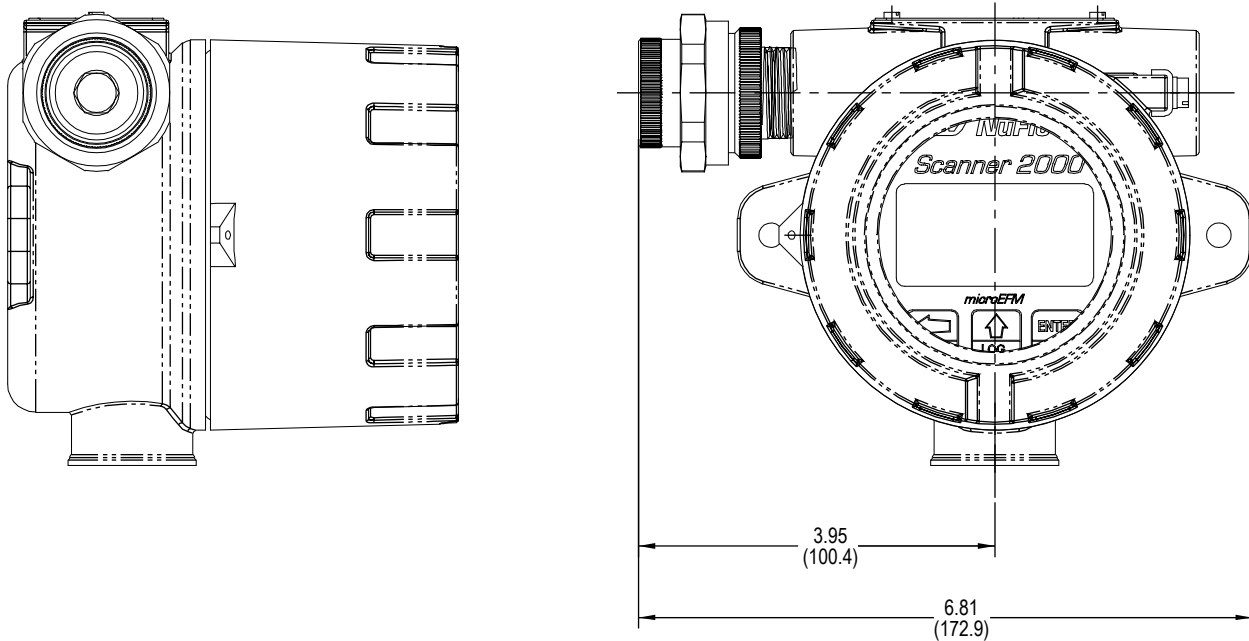

Figure A.8—Dimensions of explosion-proof communications adapter; inches (mm)

! **WARNING:** When a hazardous area is present, ensure the union nut and blanking plug are properly fitted in the conduit opening. The explosion-proof rating applies only when the union nut and blanking plug are secured in place. When the union is broken, the device is no longer explosion-proof.

! **WARNING:** Before disassembling the union nut and blanking plug, make sure the area is non-hazardous.

To connect a PC or laptop to the communications adapter, perform the following steps:

1. Unscrew the union nut to expose the connector socket shown in Figure A.7, page A-4. A blanking plug will be removed with the union nut. Store the union nut and blanking plug in a safe place. (They will need to be reinstalled when the adapter is not in use.)
2. Connect the plug connector to an RS-485 converter cable, if it is not already attached (Figure A.9).

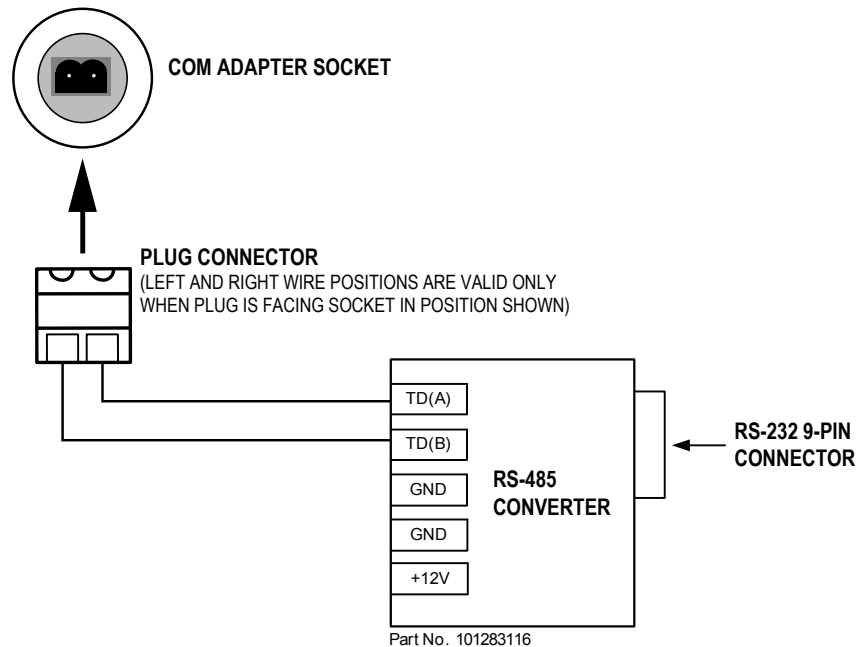

Figure A.9—Wiring of plug connector to Cameron 9-pin RS-232 to RS-485 converter cable

3. Insert the plug connector into the adapter socket.
4. Connect the converter cable to the PC or laptop.

To disconnect the adapter, remove the plug connector (with converter cable attached) from the socket, place the blanking plug inside the union nut (removed in step 1) and screw the union nut onto the union half to cover the socket. Hand-tighten to ensure a snug connection.

Note Do not disconnect the plug connector from the RS-232 to RS-485 converter cable when it is not in use. For best results, store the plug connector with the converter cable.

Communications Adapter Installation (for adapters purchased separately from a Scanner 2000)



WARNING: If the communications adapter is ordered separately from the Scanner 2000 microEFM, the conduit openings in the Scanner 2000 enclosure will be sealed with brass or stainless steel plugs. Do not remove the plug from the enclosure to install the adapter unless the area is known to be non-hazardous.

To install a communications adapter purchased separately from a Scanner 2000 microEFM, perform the following steps:

1. Thread the cable of the adapter through a conduit opening in the instrument housing and screw the adapter into place.
2. Connect the adapter cable to either communications port on the main circuit board inside the Scanner 2000 housing. See Figure 3.7, page 66, for a wiring diagram.
3. Connect the plug connector to an RS-485 converter cable, if applicable.

USB Communications Adapter

The NuFlo™ USB Adapter allows a user to connect a computer to the Scanner 2000 using a standard off-the-shelf USB connector cable for quick and easy downloads without opening the Scanner enclosure.

The USB adapter is comprised of a USB adapter socket, a blanking plug, and a union nut (Figure A.11). A CD containing the software for installing the driver is included with the adapter (either (ModWorX Pro or stand-alone NuFlo USB CD).

When the USB connection is ordered with a Scanner 2000, the USB adapter is pre-installed at the factory. No field wiring is required. If the USB adapter is purchased as a kit, see Adapter Kit Installation, page A-8, for installation instructions.

Important Do not connect the USB adapter to a computer until a USB driver is installed using the CD provided. ModWorX Pro cannot connect to a Scanner 2000 without these files. See Using the Adapter, page A-7.



Figure A.10—NuFlo USB adapter



Figure A.11—NuFlo USB adapter components

User-Supplied Hardware

To install the adapter and connect to a Scanner 2000 using USB communications, a user-supplied universal serial bus USB A/B cable is required.



Figure A.12—User-supplied USB A/B cable

Using the Adapter

The CD supplied with the NuFlo USB Adapter contains the drivers required to enable USB communications for a Scanner 2000 when the NuFlo USB Adapter is installed.

For step-by-step installation instructions, insert the CD in your computer and follow the instructions in the NuFlo USB Adapter_Readme file. The software will install the appropriate driver that is compatible with your computer's operating system.

When the software is fully installed, the adapter can be connected to the computer and used to connect to the Scanner 2000 via ModWorX Pro (Tools/Select COM Port). For more information on ModWorX Pro, see the ModWorX Pro User Manual, Part No. 9A-30165025.



WARNING: When a hazardous area is present, ensure the union nut and blanking plug are properly fitted in the conduit opening. The explosion-proof rating applies only when the union nut and blanking plug are secured in place. When the union is broken, the device is no longer explosion-proof.



WARNING: Before disassembling the union nut and blanking plug, make sure the area is non-hazardous.

Covering the Adapter

When the USB port is not in use, nest the blanking plug inside the union nut and screw the union nut onto the adapter to cover the USB socket. Hand-tighten to ensure a snug connection.

Adapter Kit Installation

If the NuFlo USB adapter is purchased as a kit, install it in the Scanner 2000 according to the steps below.

The USB adapter is comprised of a USB adapter socket, a blanking plug, and a union nut. The blanking plug and union nut are connected to the adapter only when the USB port is not in use.

1. Remove the plug from a conduit opening in the Scanner 2000 enclosure.
2. Thread the cable of the adapter through the conduit opening and screw the adapter into place.
3. Wire the adapter cable to either communications port on the Scanner 2000 main circuit board as shown in the wiring diagram (black wire to negative terminal).

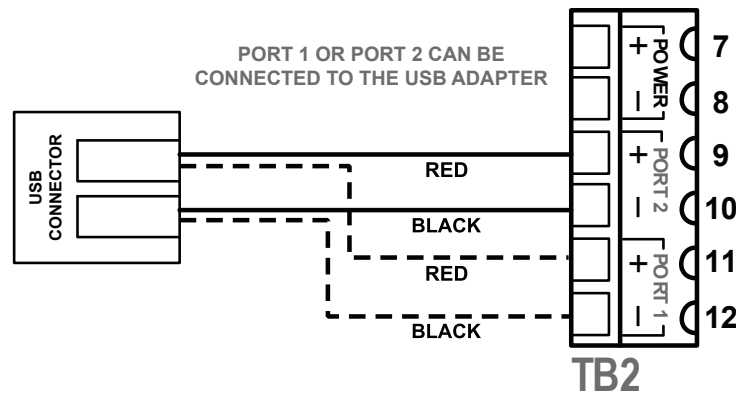

Figure A.13—Wiring of NuFlo USB adapter (required only when purchased as a kit)

4. If the USB port will not be used immediately, nest the blanking plug inside the union nut and screw the union nut onto the adapter to cover the USB socket. Hand-tighten to ensure a snug connection.

Input/Output Expansion Board

With the installation of the Scanner 2000 input/output expansion board, the instrument can support up to three flow runs simultaneously—a flow run and two turbine meter runs. All inputs and outputs are configured with ModWorX™ Pro software provided with each Scanner 2000 microEFM. See the ModWorX™ Pro Software User Manual, Part No. 9A-30165025, for details.

The expansion board shown in Figure A.14, page A-9, includes the following inputs and outputs:

- 2 analog inputs (can be configured for 0-5 V, 1-5 V or 4-20 mA)
- 1 turbine meter input
- 1 pulse input
- 1 analog output (4-20 mA)

If the expansion board is ordered with a Scanner 2000, it is installed at the factory. If the board is purchased separately, the user will need to install it on the Scanner 2000 main board using the following instructions.

Installation (for boards purchased separately from a Scanner 2000)

Important Before installing the expansion board, remove all power from the Scanner 2000 (battery and external power). Remove wiring from the main board if necessary to guide the expansion board into position.

The expansion board attaches to two headers positioned between the two large green terminal blocks on the main board. To install, perform the following steps:

1. Remove the standoff from packaging and push it into the hole near the middle of the main board until it snaps into place.
2. Guide the expansion board over the standoff and align the pins on the under side of the expansion board with the headers on the main board. **FAILURE TO ALIGN PINS AND HEADERS CAN RESULT IN DAMAGE TO THE BOARD.** When the board is positioned correctly, the text on both boards should face the same direction.
3. Gently press the expansion board and the main board together until the expansion board snaps into place over the standoff.
4. Restore field wiring connections to the main board, if applicable, and install field wiring on the expansion board.
5. Restore power to the Scanner 2000 and reboot the Scanner to allow it to detect the expansion board.

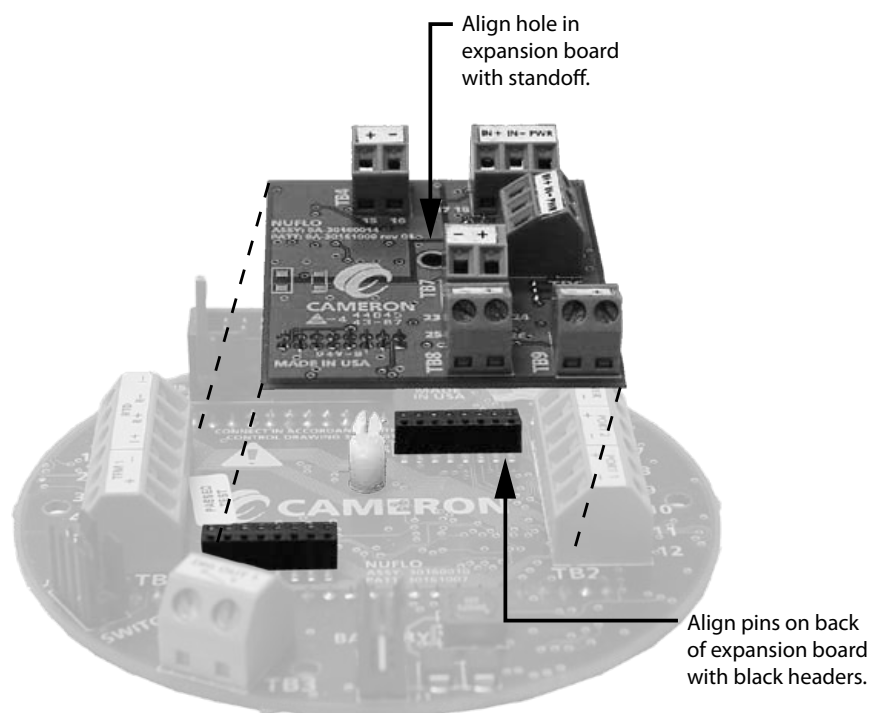

Figure A.14—Scanner 2000 input/output expansion board

Wiring Diagrams

Analog Inputs 1 and 2

The analog inputs, which can be configured for a 0-5 V, 1-5 V or 4-20 mA signal, can be used to receive readings from a pressure or temperature transmitter for use in AGA-7 gas calculations. Alternatively, they can be used to log measurements from any device with a 0-5 V, 1-5 V or 4-20 mA output.

Transmitter power is provided by the Scanner 2000 only when the Scanner is externally powered. The output voltage equals the input voltage less 0.25 VDC, and is limited to 20 mA.

If a 4-20 mA transmitter is used, a resistor must be added to the circuit, as shown in Figure A.15. The expansion board circuit will support a resistor range of 200 to 300 ohms; 250 ohms is recommended.

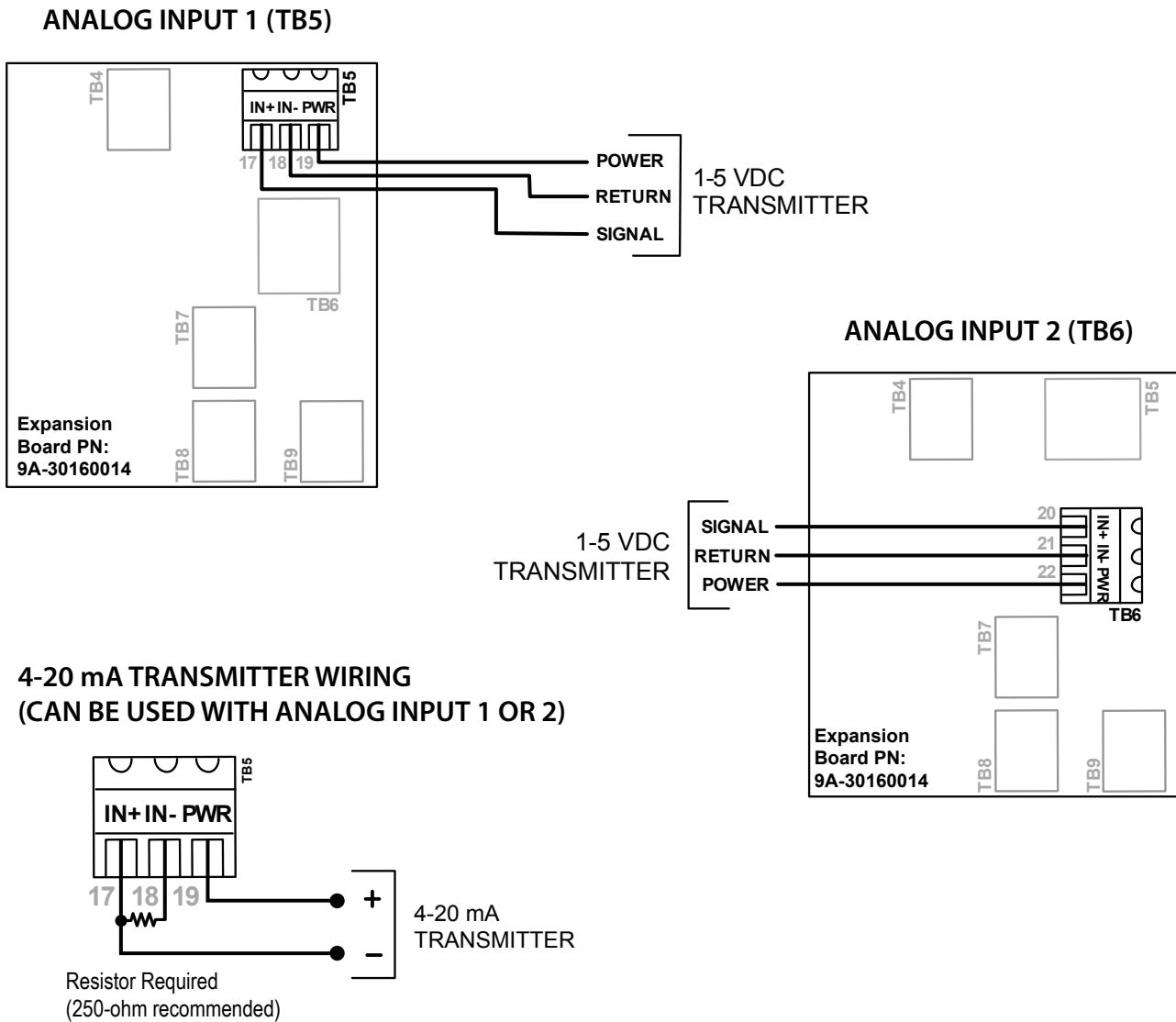

Figure A.15—0-5 V, 1-5 V and 4-20 mA analog input wiring

Pulse Input

The pulse input provides an optically isolated input for high-amplitude pulse (frequency) signals, which includes signals from a turbine meter equipped with a preamplifier (Figure A.16, top diagram) or signals from a positive displacement meter (Figure A.16, bottom diagram).

The Scanner 2000 can calculate flow from no more than two pulse (frequency) inputs at a time. Therefore, a pulse input can be used simultaneously with only one turbine input (main board or expansion board).

The pulse input can also be used as a status input for monitoring a parameter via Modbus registers. See Pulse Input for Status Indication, page C-25, for details.

PULSE INPUT (TB8)

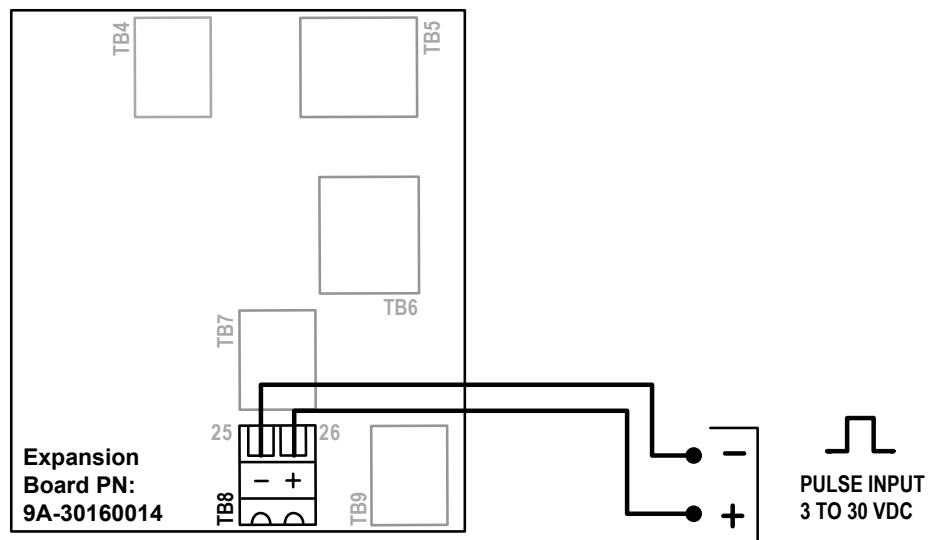

PULSE INPUT/SWITCH (TB7 &TB8)

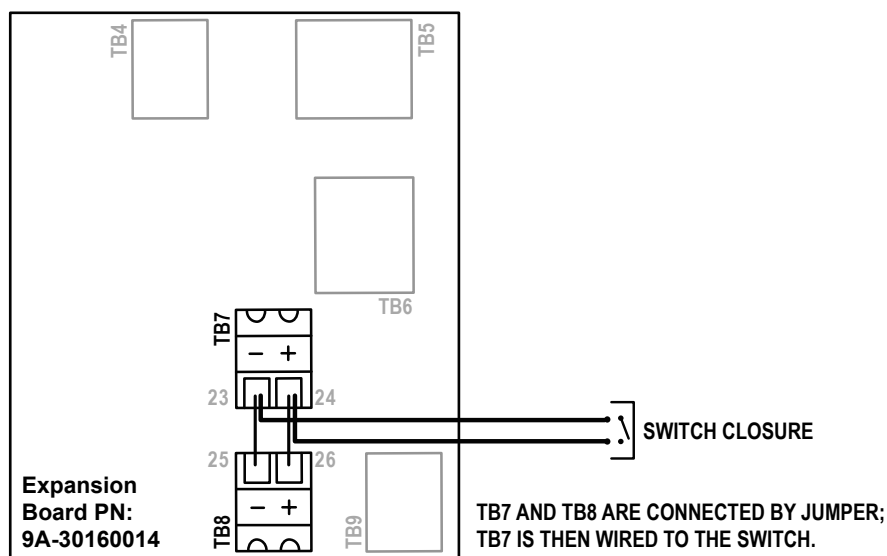

Figure A.16—Pulse input wiring

Turbine Flowmeter Input 2

Turbine Input 2 (Figure A.17) accepts a turbine flowmeter input signal generated by a magnetic pickup. The Scanner 2000 can be configured to use this signal to calculate and display instantaneous flow rates and accumulated totals. Turbine Input 2 is in addition to the turbine input on the main circuit board. When the expansion board is installed, a differential pressure flow run and two turbine runs can be monitored and logged simultaneously.

TURBINE INPUT (TB9)

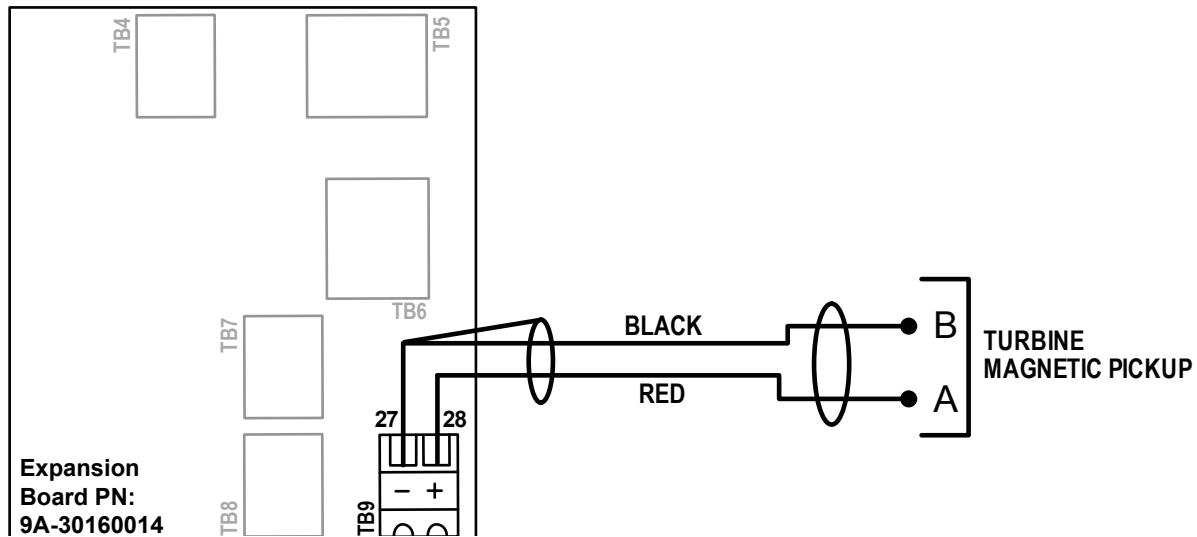

Figure A.17—Turbine Input 2 wiring

Analog (4-20 mA) Output

The 4-20 mA output provides a linear current output that can be configured using ModWorX Pro software to represent any parameter in the holding registers. This output requires a two-conductor cable to be connected to an 8 to 30 VDC power supply (voltage required is dependent on loop resistance) and a current readout device to be located in the remote location. See the ModWorX Pro Software User Manual for information on configuring zero and full-scale values using ModWorX Pro software.

The graph below the wiring diagram in Figure A.18, page A-13 shows the minimum voltage required to power the instrument for a given loop resistance. In addition, the mathematical relationship between loop voltage and load resistance is given. For example, if a power supply voltage of 24 volts is available to power the current loop, the maximum load resistance would be 800 ohms.

**ANALOG OUTPUT (TB4)
(WITH POWER SUPPLIED VIA MAIN BOARD (TB2))**

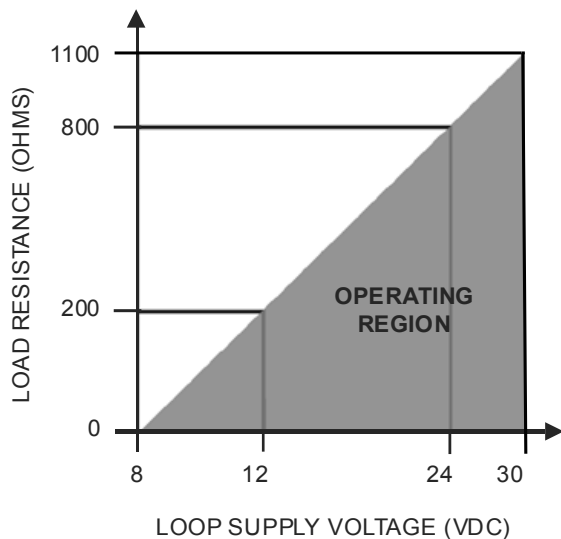
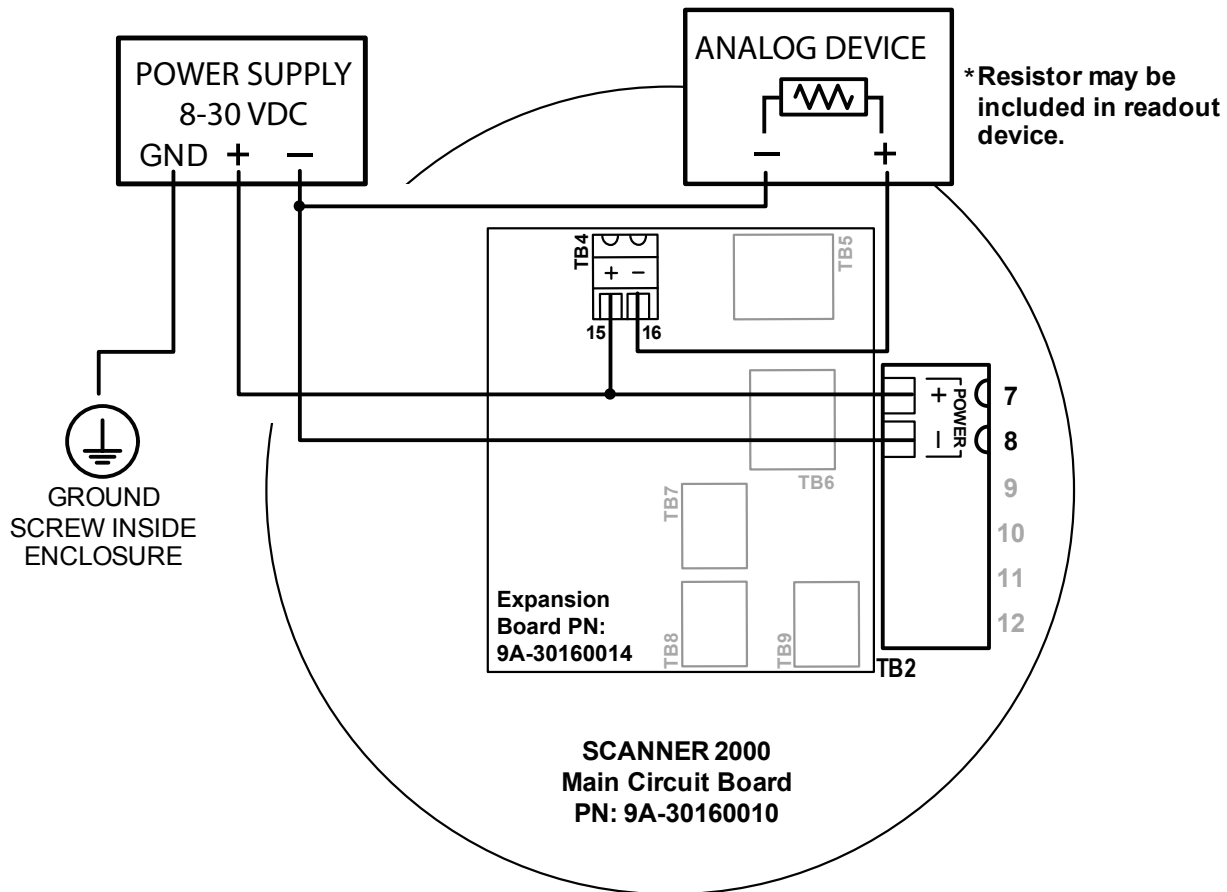

$$R_L \text{ MAX} = \frac{(V \text{ loop} - 8V)}{20 \text{ mA}}$$

$$R_L \text{ MAX} = \frac{(24V \text{ loop} - 8V)}{20 \text{ mA}}$$

$$R_L \text{ MAX} = 800 \text{ ohms}$$

Figure A.18—Analog (4-20 mA) output wiring

Measurement Canada Seal Kit

Measurement Canada has approved the use of the Scanner 2000 for custody transfer applications when it is installed in accordance with the configuration and sealing provisions cited in Measurement Canada Approval No. AG-0557C.

Measurement Canada compliance requires both the installation of a lead seal on the device and the enabling of a custody transfer device seal in software that effectively prevents the user from changing the device configuration without breaking the seal. For best results, configure the Scanner 2000 using ModWorX Pro software prior to installing the seal kit. See the ModWorX Pro User Manual, Part No. 9A-30165025, for information on configuring the device.

Seal kit components are packaged in a small plastic bag for shipment with Measurement Canada approved devices. The seal kit includes the following components:

- a double-strand seal wire with a lead seal attached to one end
- an Allen head screw drilled to accept a seal wire
- a small Allen wrench
- an S-shape metal bracket drilled to accept a seal wire
- a circuit board jumper (for activating the device configuration lock)

Measurement Canada approved units can be identified by a secondary tag containing unit specifications and the Measurement Canada approval number. The tag is affixed to the outside of the Scanner 2000 enclosure prior to shipment.

Seal Kit Installation

To install the Measurement Canada seal kit, perform the following steps.

1. Remove the cover from the Scanner 2000.
2. Remove the seal kit components from the plastic bag.
3. Remove the two screws from the Scanner 2000 switchplate and set aside.
4. Install the seal kit jumper as follows.
 - a. Pull the switchplate and circuit board assembly forward to access the back side of the circuit board.
 - b. Locate the J2 receptacle labeled “SWITCH” and insert the jumper into the header. (See Figure A.19, page A-15)

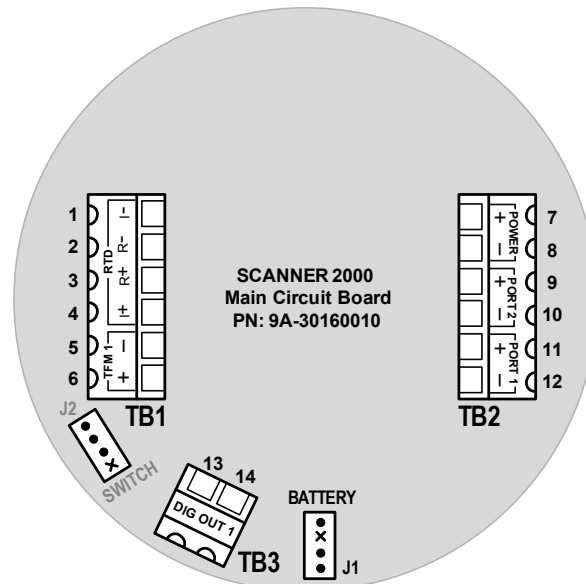

Figure A.19—J2 receptacle for installing the seal kit jumper

5. Complete field wiring, if applicable, while the circuit board is exposed.
6. Reposition the switchplate and circuit board assembly against the standoffs and secure by replacing one of the switchplate screws that was removed in step 3. Do not replace the opposite screw; the seal kit screw and bracket will be installed in its place.
7. Install the wire seal as follows:
 - a. Position the S-shaped metal bracket from the kit over the edge of the switchplate so that the screw hole in the bracket aligns with the screw hole in the switchplate (see Figure A.20, page A-16). When positioned correctly, the portion of the bracket that contains a tiny drill hole will be nearest the display.
 - b. Place the Allen head screw through the bracket and the switchplate and gently tighten with the Allen wrench provided to secure the switchplate assembly in the enclosure. Adjust the screw as required to align the drilled hole in the screw with the hole in the bracket.
 - c. Insert the free end of the seal wire through the Allen head screw and through the hole in the metal bracket (see Figure A.20, page A-16).
 - d. Thread the seal wire through the holes in the lead seal to form a loop. Pull the excess wire through the seal until the loop around the seal is approximately 1/2 in. in diameter and the seal is near the metal bracket (see Figure A.21, page A-16). Do not overtighten the seal wire; doing so will make the seal difficult to remove later.
 - e. Crimp the lead seal firmly to lock the seal wire in place and remove the excess wire.
8. Replace the cover on the enclosure.
9. Verify that the configuration settings in ModWorX Pro are accurate.
10. Enable the custody transfer device seal in the ModWorX Pro interface as described in the ModWorX Pro User Manual, Part No. 9A-30165025.



Figure A.20—Measurement Canada seal kit components

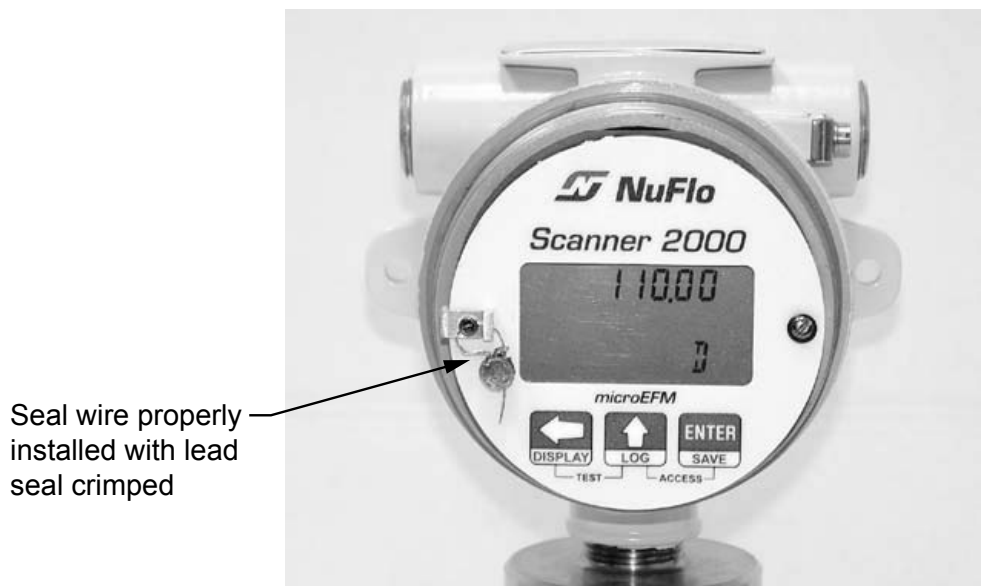

Figure A.21—Scanner 2000 with seal kit installed

Appendix B—Lithium Battery Information

Lithium Battery Disposal

Once a lithium battery is removed from a device and/or is destined for disposal, it is classified as solid waste under EPA guidelines. Depleted lithium batteries are also considered to be hazardous waste because they meet the definition of Reactivity, as per 40 CFR 261.23(a)(2), (3) and (5). This document describes how the lithium reacts violently with water, forms potentially explosive mixtures with water, and when exposed to certain pH conditions, generates toxic cyanide or sulfide gases.

Federal law requires that depleted lithium battery packs be sent to a fully permitted Treatment, Storage and Disposal Facility (TSDF) or to a permitted recycling/reclamation facility.

Important **Do not ship lithium battery packs to Cameron’s Measurement Systems Division. Cameron facilities are not permitted recycling/ reclamation facilities.**

CAUTION **Profiling and waste characterization procedures must be followed prior to shipping a lithium battery to a disposal site. It is the shipper’s responsibility to comply with all applicable federal transportation regulations (see below).**

Transportation Information



WARNING: The Scanner 2000 microEFM contains lithium batteries. The internal component (thionyl chloride) is hazardous under the criteria of the Federal OSHA Hazard Communication Standard 29 CFR 1920.1200. Before shipping a lithium battery or equipment containing a lithium battery, verify that the packaging and labeling conforms with the latest version of all applicable regulations.

The transport of the lithium batteries is regulated by the United Nations, “Model Regulations on Transport of Dangerous Goods,” (special provisions 188, 230, and 310), latest revision.

Within the US the lithium batteries and cells are subject to shipping requirements under Part 49 of the Code of Federal Regulations (49 CFR, Parts 171, 172, 173, and 175) of the US Hazardous Materials Regulations (HMR), latest revision.

Shipping of lithium batteries in aircraft is regulated by the International Civil Aviation Organization (ICAO) and the International Air Transport Association (IATA) requirements in Special Provisions A45, A88 and A99, latest revision.

Shipping of lithium batteries on sea is regulated the International Maritime Dangerous Goods (IMDG) requirements in special provisions 188, 230 and 310, latest revision.

Shipping of lithium batteries on road and rail is regulated by requirements in special provisions 188, 230 and 310, latest revision.

Material Safety Data Sheet

For a link to the current MSDS for the lithium batteries used to power the Scanner 2000 microEFM, see the Measurement Systems Division section of the Cameron website: www.c-a-m.com.

Appendix C—Communications Protocol

Communications Protocol

Firmware Version: 4.00

Register Table Version: 15

Introduction

The communications protocol for the Scanner 2000 is in accordance with Modicon, Inc. RTU Mode Modbus® as described in *Modicon Modbus Protocol Reference Guide*, PI-MBUS-300 Rev. J, June 1996. All registers are implemented as 4X or holding registers. Reading of registers is implemented via function code 03H (Read Holding Registers). Writing to registers is implemented via function code 10H (Preset Multiple Registers). The instrument provides Enron Modbus® compliant downloads for interval, daily and event records. For details on Enron Modbus®, refer to *Specifications and Requirements for an Electronic Flow Measurement Remote Terminal Unit for Enron Corp.*, Dec. 5, 1994.

Supported Commands

The Modbus® functions supported by the Scanner 2000 are as follows:

Function Code (Hex)	Description
03	Read Holding Registers
05	Preset Boolean (for Enron event record acknowledgement)
10	Preset Multiple Registers
11	Report Slave ID

For the read holding and preset multiple registers, the instrument supports the full 250 bytes of data in a message. This corresponds to 125 registers in 16-bit holding register size and 62 registers in 32-bit holding register size.

The report slave ID function code returns the following registers:

- Product Code
- Register Table Number
- Firmware Version
- Manufacture Date
- Sales Date
- Serial Number 1
- Serial Number 2
- Power Mode
- Connected Port (0 = connected to Port 1; 1 = connected to Port 2)
- Port Mode

- Port SlaveAddress
- Port BaudRate
- Port BusDelay
- Port BusTimeout
- Real Date
- Real Time

Data Types

Various data types are implemented in the Scanner 2000. The following table lists the formats and the numbers of bytes and registers associated with each type.

Data Type	Byte Count	Register Count
Floating Point (FP)	4	2
Floating Point (FP32)	4	1
Unsigned Word (U16)	2	1
Unsigned Long (U32)	4	2
Packed ASCII (PA)	2	1

The word ordering for multiple register data types, such as floating-point numbers or long integers, is for the most significant word to appear first in the message.

The Unsigned Word (U16) type is used for 16-bit integers and fits into one register.

The Packed ASCII (PA) type contains two bytes that are two unsigned characters. Generally, multiple Packed ASCII types are arranged consecutively for implementing strings. For example, the Device Name is a string of 20 unsigned characters that is implemented as 10 Packed ASCII registers. Here is an example of a device name that contains the string, "Test Well 413."

Register	Hexadecimal #	ASCII Characters
240	54 65	Te
241	73 74	st
242	20 57	<SPACE> W
243	65 6C	el
244	6C 20	I<SPACE>
245	34 31	41
246	33 FF	3<UNUSED>
247	FF FF	<UNUSED><UNUSED>
248	FF FF	<UNUSED><UNUSED>
249	FF FF	<UNUSED><UNUSED>

Unused characters at the end of each string will report 0xFF hexadecimal.

Security

To communicate with a Scanner 2000 without the use of ModWorX Pro software (i.e. via a third-party polling device), security permissions for the applicable Scanner 2000 communications port must be set to the default (unrestricted) state. If a different security level is required, contact Cameron technical support for details. Security levels can be restored to default permissions with ModWorX Pro software.

Registers

Each register has an Access type: read-only or read-write, as described below.

Access Type	Description
Read Only (RO)	Register can only be read
Read/Write (R/W)	Register can be read and written

The registers are grouped into Modbus® map blocks according to function. The Scanner 2000 contains the following map functions.

Map	Starting Register
Control Registers	70
System Configuration	1000
Communications Configuration	1100
Real Time	1200
Power Configuration	1300
Archive Configuration	1400
Turbine 1 Configuration	2000
Turbine 1 Calibration	2030
Turbine 2 Configuration	2100
Turbine 2 Calibration	2130
Static Pressure Configuration	2200
Static Pressure Calibration	2230
RTD Configuration	2300
RTD Calibration	2330
Differential Pressure Configuration	2400
Differential Pressure Calibration	2430
Analog Input 1 Configuration	2500
Analog Input 1 Calibration	2530
Analog Input 2 Configuration	2600
Analog Input 2 Calibration	2630
Flow Run 1 Configuration	3000
Flow Run 1 Calibration	3200
Flow Run Alarms	3600
Output Configuration	4000
Holding Registers (32-bit)	7000
Holding Registers	8000
User-Defined Holding Register Configuration	9000

Map	Starting Register
User-Defined Holding Registers	9100
Device Status	9900

Note: All registers cited in this document refer to the address of the register that appears in the actual Modbus® message. For example, register 8000 has an address of 0x1F40 hexadecimal in the message.

Control Registers

Register (Decimal)	Register (Hex)	Description	Data Type	Access
70	46	Control Register 1	U16	R/W

The Control Registers allow specific functions to be implemented via the communications port. The following table shows the value to be written to the control register to implement the desired function.

Code	Function
20000	Transfers the polling totals and averages and polling run times to the previous polling totals, averages and previous run-time registers, increments the polling index register, and resets the polling totals, averages and polling run-time registers.
30000	Clears all flow totals
30001	Clears Flow Run 1 totals
30003	Clears Turbine 1 totals
30004	Clear Turbine 2 totals
30050	Clears all pulse output latches
30051	Clears a Pulse Output 1 latch
30061	Adds pulses specified in Control Register 2 to Pulse Output 1 Accumulator
30100	Clear all Alarm States
30101	Clear Flow Run Alarm Status
30102	Clear Input Alarm Status
40000	Loads factory defaults
40040	Resets the microcontroller (watchdog)
50050	Creates a partial archive record (daily and interval)

System Configuration

Register (Decimal)	Register (Hex)	Description	Data Type	Access
1000	3E8	Product Code and Feature Privileges	U16	RO
1001	3E9	Register Table Version	U16	RO
1002	3EA	Firmware Version	U16	RO
1003	3EB	Manufacture Date	U16	RO
1004	3EC	Sales Date	U16	RO
1005	3ED	Serial Number High	U16	RO
1006	3EE	Serial Number Low	U16	RO
1007	3EF	Sensor Serial Number[0]	PA	RO
1008	3F0	Sensor Serial Number[1]	PA	RO
1009	3F1	Sensor Serial Number[2]	PA	RO
1010	3F2	Sensor Serial Number[3]	PA	RO
1011	3F3	Sensor Serial Number[4]	PA	RO
1012	3F4	Sensor Serial Number[5]	PA	RO
1013	3F5	Expansion Board Manufacture Date	U16	RO
1014	3F6	Expansion Board Sales Date	U16	RO
1015	3F7	Expansion Board Serial Number High	U16	RO
1016	3F8	Expansion Board Serial Number Low	U16	RO
1017	3F9	Expansion Board Configuration	U16	RO

Product Code

The Product Code is a read-only parameter used for identifying a Scanner 2000 device and its enabled advanced features (such as PID controller and Modbus Master) using the ModWorX Pro software. This parameter is defined at the factory.

Firmware Version/Register Table Version

The Firmware Version and Register Table Version numbers are set by the factory and are read-only. To determine the version number, read the appropriate register and divide the value by 100. The general format for version numbers is A.BC. For example the firmware register number is read as 0xA7 hexadecimal. This represents the value 167 and a firmware version of 1.67.

Manufacture Date/Sales Date

These parameters are set at the factory and are read-only. These registers are formatted as MMY. For example, a value of 0908 represents the date September 2008.

Communications Configuration

Register (Decimal)	Register (Hex)	Description	Data Type	Access	Default
1100	44C	Port 1 - Port Usage 0 - Slave 1 - Master	U16	R/W	0
1101	44D	Port 1 Slave Address [1 to 65535, excluding 252 to 255 and 64764]	U16	R/W	1
1102	44E	Port 1 - Baud Rate 0 - 300 1 - 600 2 - 1200 3 - 2400 4 - 4800 5 - 9600 6 - 19200 7 - 38400 8 - 57600 9 - 115200	U16	R/W	5
1103	44F	Port 1 - Bus Delay mS of delay before transmitting data	U16	R/W	10
1104	450	Port 1 - Bus Timeout mS of delay before resetting communications	U16	R/W	50
1105	451	Port 2 - Port Usage 0 - Slave Only	U16	R/W	0
1106	452	Port 2 Slave Address [1 to 65535, excluding 252 to 255 and 64764]	U16	R/W	1
1107	453	Port 2 - Baud Rate 0 - 300 1 - 600 2 - 1200 3 - 2400 4 - 4800 5 - 9600 6 - 19200 7 - 38400 8 - 57600 9 - 115200	U16	R/W	5
1108	454	Port 2 - Bus Delay mS of delay before transmitting data	U16	R/W	10
1109	455	Port 2 - Bus Timeout mS of delay before resetting communications	U16	R/W	50

Real Time

Register (Decimal)	Register (Hex)	Description	Data Type	Access
1200	4B0	Year (Real Year = register value plus 2000)	U16	R/W
1201	4B1	Month [1-12]	U16	R/W
1202	4B2	Day [1-31]	U16	R/W
1203	4B3	Hour [0-23]	U16	R/W
1204	4B4	Minute [0-59]	U16	R/W
1205	4B5	Second [0-59]	U16	R/W

This block of registers is used to set the instrument's internal clock. To set the time, it is recommended that all registers be written in one message.

The time and date can also be read in the holding register groups as floating-point data.

Power Configuration

Register (Decimal)	Register (Hex)	Description	Data Type	Access	Default
1300	514	Power Mode 0 - High Power 1 - Low Power	U16	R/W	1
1301	515	Clock Override	U16	R/W	0
1302	516	Internal System Sample Period [number of seconds between battery voltage and electronics temperature measurements]	U16	R/W	3600
1303	517	External Sensor Power Control Sensor Warmup Time [0 – 2048 sec] Add 32768 to lock sensor power on.	U16	R/W	32770

Archive Configuration

Register (Decimal)	Register (Hex)	Description	Data Type	Access	Default
1400	578	Archive Reference Number	U16	RO	10000
1401	579	Contract Hour [0-23]	U16	R/W	8 (AM)
1402	57A	Interval Period [5 seconds to 12 hours]	U16	R/W	3600 seconds (1 hour)
1403	57B	Partial Records 0 - Not Enabled 1 – Enabled	U16	R/W	0
1404	57C	Number of Daily Records	U16	RO	768
1405	57D	Number of Interval Records	U16	RO	2304 (std.); 6392 with expansion board
1406	57E	Number of Events Records	U16	RO	1152
1407	57F	Number of Parameters	U16	R/W	11
1408	580	Archive Field 1	U16	RO	Date
1409	581	Archive Field 2	U16	RO	Time
1410	582	Archive Field 3	U16	R/W	FR1 Volume
1411	583	Archive Field 4	U16	R/W	FR1 Mass
1412	584	Archive Field 5	U16	R/W	FR1 Energy
1413	585	Archive Field 6	U16	R/W	Differential Pressure
1414	586	Archive Field 7	U16	R/W	Static Pressure
1415	587	Archive Field 8	U16	R/W	Process Temperature
1416	588	Archive Field 9	U16	R/W	FR1 Run Time
1417	589	Archive Field 10	U16	R/W	T1 Volume

Archive Configuration

Register (Decimal)	Register (Hex)	Description	Data Type	Access	Default
1418	58A	Archive Field 11	U16	R/W	T1 Run Time
1419	58B	Archive Field 12	U16	R/W	Unused
1420	58C	Archive Field 13	U16	R/W	Unused
1421	58D	Archive Field 14	U16	R/W	Unused
1422	58E	Archive Field 15	U16	R/W	Unused
1423	58F	Archive Field 16	U16	R/W	Unused

Turbine 1 Configuration

Register (Decimal)	Register (Hex)	Description	Data Type	Access	Default
2000	7D0	T1 - Units See Units Table	U16	R/W	102 – BBL
2001	7D1	T1 - Time Base 0 = Second 1 = Minute 2 = Hour 3 = Day	U16	R/W	3
2002	7D2	T1 - Sampling Period (sec)	U16	R/W	5
2003	7D3	T1 - Dampening Factor	U16	R/W	0
2004	7D4	T1 - Input Configuration 0 - TFM Low (20 mV @ <1000 Hz) 1 - TFM Med (50 mV @ <1000 Hz) 2 - TFM High (100 mV @ <1000 Hz) 3 - TFM Max (200 mV @ <1000 Hz) 4 - Pulse Input	U16	R/W	1
2005	7D5	T1 - Override Enable 0 - Disabled 1 - Enabled	U16	R/W	0
2006	7D6	T1 - Override Value	FP	R/W	0.00
2008	7D8	T1 - Fail Value	FP	R/W	0.00
2010	7DA	T1 - Low Frequency Cutoff	FP	R/W	5.00
2012	7DC	T1 - Low Flow Cutoff	FP	R/W	0.00
2014	7DE	T1 - Sensor Range Low	FP	R/W	0.00
2016	7E0	T1 - Sensor Range High	FP	R/W	0.833333333
2018	7E2	T1 - Units Scale Factor	FP	R/W	0.023809524
2020	7E4	T1 - Units Offset Factor	FP	R/W	0
2022	7E6	T1 - Unit Description 1	LCD	R/W	—
2023	7E7	T1 - Unit Description 2	LCD	R/W	—
2024	7E8	T1 - Unit Description 3	LCD	R/W	—

Turbine 1 Calibration

Register (Decimal)	Register (Hex)	Description	Data Type	Access	Default
2030	7EE	T1 - Calibration Type ¹	U16	R/W	1
2031	7EF	T1 - Linear Factor	FP	R/W	900.00
2033	7F1	T1 - Calibration Absolute Offset	FP	R/W	0.00
2035	7F3	T1 - Factor 1	FP	R/W	900.00
2037	7F5	T1 - Factor 2	FP	R/W	1.00
2039	7F7	T1 - Factor 3	FP	R/W	1.00
2041	7F9	T1 - Factor 4	FP	R/W	1.00
2043	7FB	T1 - Factor 5	FP	R/W	1.00
2045	7FD	T1 - Factor 6	FP	R/W	1.00
2047	7FF	T1 - Factor 7	FP	R/W	1.00
2049	801	T1 - Factor 8	FP	R/W	1.00
2051	803	T1 - Factor 9	FP	R/W	1.00
2053	805	T1 - Factor 10	FP	R/W	1.00
2055	807	T1 - Factor 11	FP	R/W	1.00
2057	809	T1 - Factor 12	FP	R/W	1.00
2059	80B	T1 - Frequency 1	FP	R/W	1.00
2061	80D	T1 - Frequency 2	FP	R/W	1.00
2063	80F	T1 - Frequency 3	FP	R/W	1.00
2065	811	T1 - Frequency 4	FP	R/W	1.00
2067	813	T1 - Frequency 5	FP	R/W	1.00
2069	815	T1 - Frequency 6	FP	R/W	1.00
2071	817	T1 - Frequency 7	FP	R/W	1.00
2073	819	T1 - Frequency 8	FP	R/W	1.00
2075	81B	T1 - Frequency 9	FP	R/W	1.00
2077	81D	T1 - Frequency 10	FP	R/W	1.00
2079	81F	T1 - Frequency 11	FP	R/W	1.00
2081	821	T1 - Frequency 12	FP	R/W	1.00

¹ The Calibration Type register must be configured using ModWorX Pro. This register defines the type and number of calibration points used. If altered manually, calibration points must be entered in ascending order.

Turbine 2 Configuration

Register (Decimal)	Register (Hex)	Description	Data Type	Access	Default
2100	834	T2 - Units See Units Table	U16	R/W	102 – BBL
2101	835	T2 - Time Base	U16	R/W	3 – Day
2102	836	T2 - Sampling Period (sec)	U16	R/W	5
2103	837	T2 - Dampening Factor	U16	R/W	0
2104	838	T2 - Input Configuration 0 - TFM Low (20 mV @ <1000 Hz) 1 - TFM Med (50 mV @ <1000 Hz) 2 - TFM High (100 mV @ <1000 Hz) 3 - TFM Max (200 mV @ <1000 Hz) 4 - Pulse Input (on expansion board)	U16	R/W	1
2105	839	T2 - Override Enable 0 - Disabled 1 - Enabled	U16	R/W	0
2106	83A	T2 - Override Value	FP	R/W	0.00
2108	83C	T2 - Fail Value	FP	R/W	0.00
2110	83E	T2 - Low Frequency Cutoff	FP	R/W	5.00
2112	840	T2 - Low Flow Cutoff	FP	R/W	0.00
2114	842	T2 - Sensor Range Low	FP	R/W	0.00
2116	844	T2 - Sensor Range High	FP	R/W	0.83333333
2118	846	T2 - Units Scale Factor	FP	R/W	0.02380952
2120	848	T2 - Units Offset Factor	FP	R/W	0.00
2122	84A	T2 - Unit Description 1	LCD	R/W	—
2123	84B	T2 - Unit Description 2	LCD	R/W	—
2124	84C	T2 - Unit Description 3	LCD	R/W	—

Turbine 2 Calibration

Register (Decimal)	Register (Hex)	Description	Data Type	Access	Default
2130	852	T2 - Calibration Type ¹	U16	R/W	1
2131	853	T2 - Linear Factor	FP	R/W	900.00
2133	855	T2 - Calibration Absolute Offset	FP	R/W	0.00
2135	857	T2 - Factor 1	FP	R/W	900.00
2137	859	T2 - Factor 2	FP	R/W	1.00
2139	85B	T2 - Factor 3	FP	R/W	1.00
2141	85D	T2 - Factor 4	FP	R/W	1.00
2143	85F	T2 - Factor 5	FP	R/W	1.00
2145	861	T2 - Factor 6	FP	R/W	1.00
2147	863	T2 - Factor 7	FP	R/W	1.00
2149	865	T2 - Factor 8	FP	R/W	1.00
2151	867	T2 - Factor 9	FP	R/W	1.00
2153	869	T2 - Factor 10	FP	R/W	1.00

Turbine 2 Calibration

Register (Decimal)	Register (Hex)	Description	Data Type	Access	Default
2155	86B	T2 - Factor 11	FP	R/W	1.00
2157	86D	T2 - Factor 12	FP	R/W	1.00
2159	86F	T2 - Frequency 1	FP	R/W	1.00
2161	871	T2 - Frequency 2	FP	R/W	1.00
2163	873	T2 - Frequency 3	FP	R/W	1.00
2165	875	T2 - Frequency 4	FP	R/W	1.00
2167	877	T2 - Frequency 5	FP	R/W	1.00
2169	879	T2 - Frequency 6	FP	R/W	1.00
2171	87B	T2 - Frequency 7	FP	R/W	1.00
2173	87D	T2 - Frequency 8	FP	R/W	1.00
2175	87F	T2 - Frequency 9	FP	R/W	1.00
2177	881	T2 - Frequency 10	FP	R/W	1.00
2179	883	T2 - Frequency 11	FP	R/W	1.00
2181	885	T2 - Frequency 12	FP	R/W	1.00

¹ The Calibration Type register must be configured using ModWorX Pro. This register defines the type and number of calibration points used. If altered manually, calibration points must be entered in ascending order.

Static Pressure Configuration

Register (Decimal)	Register (Hex)	Description	Data Type	Access	Default
2200	898	SP - Units See Units Table	U16	R/W	301
2201	899	SP - Time Base	U16	R/W	0
2202	89A	SP - Sampling Period	U16	R/W	1
2203	89B	SP - Dampening Factor	U16	R/W	0
2204	89C	SP - Input Configuration	U16	R/W	1
2205	89D	SP - Override Enable 0 - Disabled 1 - Enabled 2 - Flow Dependent Averaging	U16	R/W	2
2206	89E	SP - Override Value	FP	R/W	0.00
2208	8A0	SP - Fail Value	FP	R/W	0.00
2210	8A2	SP - Low Input Cutoff	FP	R/W	0.00
2212	8A4	SP - Low Flow Cutoff	FP	R/W	0.00
2214	8A6	SP - Sensor Range Low	FP	RO	from MVT
2216	8A8	SP - Sensor Range High	FP	RO	from MVT
2218	8AA	SP - Units Scale Factor	FP	R/W	1.00
2220	8AC	SP - Units Offset Factor	FP	R/W	0.00
2222	8AE	SP - Unit Description 1	LCD	R/W	

Static Pressure Configuration

Register (Decimal)	Register (Hex)	Description	Data Type	Access	Default
2223	8AF	SP - Unit Description 2	LCD	R/W	
2224	8B0	SP - Unit Description 3	LCD	R/W	

Static Pressure Calibration

Register (Decimal)	Register (Hex)	Description	Data Type	Access	Default
2230	8B6	SP - Calibration Type ¹	U16	R/W	0
2231	8B7	SP - Nominal Value	FP	R/W	1.00
2233	8B9	SP - Calibration Absolute Offset	FP	R/W	0.00
2235	8BB	SP - Calibration Actual 1	FP	R/W	0.00
2237	8BD	SP - Calibration Actual 2	FP	R/W	0.00
2239	8BF	SP - Calibration Actual 3	FP	R/W	0.00
2241	8C1	SP - Calibration Actual 4	FP	R/W	0.00
2243	8C3	SP - Calibration Actual 5	FP	R/W	0.00
2245	8C5	SP - Calibration Actual 6	FP	R/W	0.00
2247	8C7	SP - Calibration Actual 7	FP	R/W	0.00
2249	8C9	SP - Calibration Actual 8	FP	R/W	0.00
2251	8CB	SP - Calibration Actual 9	FP	R/W	0.00
2253	8CD	SP - Calibration Actual 10	FP	R/W	0.00
2255	8CF	SP - Calibration Actual 11	FP	R/W	0.00
2257	8D1	SP - Calibration Actual 12	FP	R/W	0.00
2259	8D3	SP - Calibration Measured 1	FP	R/W	0.00
2261	8D5	SP - Calibration Measured 2	FP	R/W	0.00
2263	8D7	SP - Calibration Measured 3	FP	R/W	0.00
2265	8D9	SP - Calibration Measured 4	FP	R/W	0.00
2267	8DB	SP - Calibration Measured 5	FP	R/W	0.00
2269	8DD	SP - Calibration Measured 6	FP	R/W	0.00
2271	8DF	SP - Calibration Measured 7	FP	R/W	0.00
2273	8E1	SP - Calibration Measured 8	FP	R/W	0.00
2275	8E3	SP - Calibration Measured 9	FP	R/W	0.00
2277	8E5	SP - Calibration Measured 10	FP	R/W	0.00
2279	8E7	SP - Calibration Measured 11	FP	R/W	0.00
2281	8E9	SP - Calibration Measured 12	FP	R/W	0.00

¹ The Calibration Type register must be configured using ModWorX Pro. This register defines the type and number of calibration points used. If altered manually, calibration points must be entered in ascending order.

RTD Configuration

Register (Decimal)	Register (Hex)	Description	Data Type	Access	Default
2300	8FC	PT - Units See Units Table	U16	R/W	501
2301	8FD	PT - Time Base 0 = Second 1 = Minute 2 = Hour 3 = Day	U16	R/W	0
2302	8FE	PT - Sampling Period (sec)	U16	R/W	5
2303	8FF	PT - Dampening Factor	U16	R/W	0
2304	900	PT - Input Configuration	U16	R/W	0
2305	901	PT - Override Enable 0 - Disabled 1 - Enabled 2 - Flow Dependent Averaging	U16	R/W	2
2306	902	PT - Override Value	FP	R/W	0.00
2308	904	PT - Fail Value	FP	R/W	60.00 Deg F
2310	906	PT - Low Input Cutoff	FP	R/W	-100.00 Deg F
2312	908	PT - Low Flow Cutoff	FP	R/W	-100.00
2314	90A	PT - Sensor Range Low	FP	RO	-40.00 Deg F
2316	90C	PT - Sensor Range High	FP	RO	300.00 Deg F
2318	90E	PT - Units Scale Factor	FP	R/W	1.80
2320	910	PT - Units Offset Factor	FP	R/W	32.00
2322	912	PT - Unit Description 1	LCD	R/W	—
2323	913	PT - Unit Description 2	LCD	R/W	—
2324	914	PT - Unit Description 3	LCD	R/W	—

RTD Calibration

Register (Decimal)	Register (Hex)	Description	Data Type	Access	Default
2330	91A	PT - Calibration Type ¹	U16	R/W	0
2331	91B	PT - Nominal Value	FP	R/W	1.00
2333	91D	PT - Calibration Absolute Offset	FP	R/W	0.00
2335	91F	PT - Calibration Actual 1	FP	R/W	0.00
2337	921	PT - Calibration Actual 2	FP	R/W	0.00
2339	923	PT - Calibration Actual 3	FP	R/W	0.00
2341	925	PT - Calibration Actual 4	FP	R/W	0.00
2343	927	PT - Calibration Actual 5	FP	R/W	0.00
2345	929	PT - Calibration Actual 6	FP	R/W	0.00
2347	92B	PT - Calibration Actual 7	FP	R/W	0.00
2349	92D	PT - Calibration Actual 8	FP	R/W	0.00
2351	92F	PT - Calibration Actual 9	FP	R/W	0.00

RTD Calibration

Register (Decimal)	Register (Hex)	Description	Data Type	Access	Default
2353	931	PT - Calibration Actual 10	FP	R/W	0.00
2355	933	PT - Calibration Actual 11	FP	R/W	0.00
2357	935	PT - Calibration Actual 12	FP	R/W	0.00
2359	937	PT - Calibration Measured 1	FP	R/W	0.00
2361	939	PT - Calibration Measured 2	FP	R/W	0.00
2363	93B	PT - Calibration Measured 3	FP	R/W	0.00
2365	93D	PT - Calibration Measured 4	FP	R/W	0.00
2367	93F	PT - Calibration Measured 5	FP	R/W	0.00
2369	941	PT - Calibration Measured 6	FP	R/W	0.00
2371	943	PT - Calibration Measured 7	FP	R/W	0.00
2373	945	PT - Calibration Measured 8	FP	R/W	0.00
2375	947	PT - Calibration Measured 9	FP	R/W	0.00
2377	949	PT - Calibration Measured 10	FP	R/W	0.00
2379	94B	PT - Calibration Measured 11	FP	R/W	0.00
2381	94D	PT - Calibration Measured 12	FP	R/W	0.00

¹ The Calibration Type register must be configured using ModWorX Pro. This register defines the type and number of calibration points used. If altered manually, calibration points must be entered in ascending order.

Differential Pressure Configuration

Register (Decimal)	Register (Hex)	Description	Data Type	Access	Default
2400	960	DP - Units See Units Table	U16	R/W	401
2401	961	DP - Time Base 0 = Second 1 = Minute 2 = Hour 3 = Day	U16	R/W	0
2402	962	DP - Sampling Period (seconds)	U16	R/W	1
2403	963	DP - Dampening Factor	U16	R/W	0
2404	964	DP - Input Configuration	U16	R/W	0
2405	965	DP - Override Enable 0 - Disabled 1 - Enabled 2 - Flow Dependent Averaging	U16	R/W	2
2406	966	DP - Override Value	FP	R/W	0.00
2408	968	DP - Fail Value	FP	R/W	0.00
2410	96A	DP - Low Input Cutoff	FP	R/W	0.00
2412	96C	DP - Low Flow Cutoff	FP	R/W	0.00
2414	96E	DP - Sensor Range Low	FP	RO	from MVT
2416	970	DP - Sensor Range High	FP	RO	from MVT

Differential Pressure Configuration

Register (Decimal)	Register (Hex)	Description	Data Type	Access	Default
2418	972	DP - Units Scale Factor	FP	R/W	1.00
2420	974	DP - Units Offset Factor	FP	R/W	0.00
2422	976	DP - Unit Description 1	LCD	R/W	—
2423	977	DP - Unit Description 2	LCD	R/W	—
2424	978	DP - Unit Description 3	LCD	R/W	—

Differential Pressure Calibration

Register (Decimal)	Register (Hex)	Description	Data Type	Access	Default
2430	97E	DP - Calibration Type ¹	U16	R/W	0
2431	97F	DP - Nominal Value	FP	R/W	1.00
2433	981	DP - Calibration Absolute Offset	FP	R/W	0.00
2435	983	DP - Calibration Actual 1	FP	R/W	0.00
2437	985	DP - Calibration Actual 2	FP	R/W	0.00
2439	987	DP - Calibration Actual 3	FP	R/W	0.00
2441	989	DP - Calibration Actual 4	FP	R/W	0.00
2443	98B	DP - Calibration Actual 5	FP	R/W	0.00
2445	98D	DP - Calibration Actual 6	FP	R/W	0.00
2447	98F	DP - Calibration Actual 7	FP	R/W	0.00
2449	991	DP - Calibration Actual 8	FP	R/W	0.00
2451	993	DP - Calibration Actual 9	FP	R/W	0.00
2453	995	DP - Calibration Actual 10	FP	R/W	0.00
2455	997	DP - Calibration Actual 11	FP	R/W	0.00
2457	999	DP - Calibration Actual 12	FP	R/W	0.00
2459	99B	DP - Calibration Measured 1	FP	R/W	0.00
2461	99D	DP - Calibration Measured 2	FP	R/W	0.00
2463	99F	DP - Calibration Measured 3	FP	R/W	0.00
2465	9A1	DP - Calibration Measured 4	FP	R/W	0.00
2467	9A3	DP - Calibration Measured 5	FP	R/W	0.00
2469	9A5	DP - Calibration Measured 6	FP	R/W	0.00
2471	9A7	DP - Calibration Measured 7	FP	R/W	0.00
2473	9A9	DP - Calibration Measured 8	FP	R/W	0.00
2475	9AB	DP - Calibration Measured 9	FP	R/W	0.00
2477	9AD	DP - Calibration Measured 10	FP	R/W	0.00
2479	9AF	DP - Calibration Measured 11	FP	R/W	0.00
2481	9B1	DP - Calibration Measured 12	FP	R/W	0.00

¹ The Calibration Type register must be configured using ModWorX Pro. This register defines the type and number of calibration points used. If altered manually, calibration points must be entered in ascending order.

Analog Input 1 Configuration

Register (Decimal)	Register (Hex)	Description	Data Type	Access	Default
2500	9C4	A1 - Units	U16	R/W	0
2501	9C5	A1 - Time Base	U16	R/W	0
2502	9C6	A1 - Sampling Period	U16	R/W	1
2503	9C7	A1 - Dampening Factor	U16	R/W	0
2504	9C8	A1 - Input Configuration	U16	R/W	0
2505	9C9	A1 - Override Enable	U16	R/W	0
2506	9CA	A1 - Override Value	FP	R/W	0.00
2508	9CC	A1 - Fail Value	FP	R/W	0.00
2510	9CE	A1 - Low Input Cutoff	FP	R/W	2.00
2512	9D0	A1 - Low Flow Cutoff	FP	R/W	0.00
2514	9D2	A1 - Sensor Range Low	FP	RO	0.00
2516	9D4	A1 - Sensor Range High	FP	RO	0
2518	9D6	A1 - Units Scale Factor	FP	R/W	1
2520	9D8	A1 - Units Offset Factor	FP	R/W	0
2522	9DA	A1 - Unit Description 1	LCD	R/W	—
2523	9DB	A1 - Unit Description 2	LCD	R/W	—
2524	9DC	A1 - Unit Description 3	LCD	R/W	—

Analog Input 1 Calibration

Register (Decimal)	Register (Hex)	Description	Data Type	Access	Default
2530	9E2	A1 - Calibration Type ¹	U16	R/W	0
2531	9E3	A1 - Nominal Value	FP	R/W	—
2533	9E5	A1 - Calibration Absolute Offset	FP	R/W	0.00
2535	9E7	A1 - Calibration Actual 1	FP	R/W	0.00
2537	9E9	A1 - Calibration Actual 2	FP	R/W	0.00
2539	9EB	A1 - Calibration Actual 3	FP	R/W	0.00
2541	9ED	A1 - Calibration Actual 4	FP	R/W	0.00
2543	9EF	A1 - Calibration Actual 5	FP	R/W	0.00
2545	9F1	A1 - Calibration Actual 6	FP	R/W	0.00
2547	9F3	A1 - Calibration Actual 7	FP	R/W	0.00
2549	9F5	A1 - Calibration Actual 8	FP	R/W	0.00
2551	9F7	A1 - Calibration Actual 9	FP	R/W	0.00
2553	9F9	A1 - Calibration Actual 10	FP	R/W	0.00
2555	9FB	A1 - Calibration Actual 11	FP	R/W	0.00
2557	9FD	A1 - Calibration Actual 12	FP	R/W	0.00
2559	9FF	A1 - Calibration Measured 1	FP	R/W	0.00
2561	A01	A1 - Calibration Measured 2	FP	R/W	0.00
2563	A03	A1 - Calibration Measured 3	FP	R/W	0.00
2565	A05	A1 - Calibration Measured 4	FP	R/W	0.00

Analog Input 1 Calibration

Register (Decimal)	Register (Hex)	Description	Data Type	Access	Default
2567	A07	A1 - Calibration Measured 5	FP	R/W	0.00
2569	A09	A1 - Calibration Measured 6	FP	R/W	0.00
2571	A0B	A1 - Calibration Measured 7	FP	R/W	0.00
2573	A0D	A1 - Calibration Measured 8	FP	R/W	0.00
2575	A0F	A1 - Calibration Measured 9	FP	R/W	0.00
2577	A11	A1 - Calibration Measured 10	FP	R/W	0.00
2579	A13	A1 - Calibration Measured 11	FP	R/W	0.00
2581	A15	A1 - Calibration Measured 12	FP	R/W	0.00

¹ The Calibration Type register must be configured using ModWorX Pro. This register defines the type and number of calibration points used. If altered manually, calibration points must be entered in ascending order.

Analog Input 2 Configuration

Register (Decimal)	Register (Hex)	Description	Data Type	Access	Default
2600	A28	A2 - Units	U16	R/W	0
2601	A29	A2 - Time Base	U16	R/W	0
2602	A2A	A2 - Sampling Period	U16	R/W	1
2603	A2B	A2 - Dampening Factor	U16	R/W	0
2604	A2C	A2 - Input Config	U16	R/W	0
2605	A2D	A2 - Override Enable	U16	R/W	0
2606	A2E	A2 - Override Value	FP	R/W	0.00
2608	A30	A2 - Fail Value	FP	R/W	0.00
2610	A32	A2 - Low Input Cutoff	FP	R/W	2.00
2612	A34	A2 - Low Flow Cutoff	FP	R/W	0.00
2614	A36	A2 - Sensor Range Low	FP	RO	0.00
2616	A38	A2 - Sensor Range High	FP	RO	0
2618	A3A	A2 - Units Scale Factor	FP	R/W	1
2620	A3C	A2 - Units Offset Factor	FP	R/W	0
2622	A3E	A2 - Unit Description 1	LCD	R/W	—
2623	A3F	A2 - Unit Description 2	LCD	R/W	—
2624	A40	A2 - Unit Description 3	LCD	R/W	—

Analog Input 2 Calibration

Register (Decimal)	Register (Hex)	Description	Data Type	Access	Default
2630	A46	A2 - Calibration Type ¹	U16	R/W	0
2631	A47	A2 - Nominal Value	FP	R/W	—
2633	A49	A2 - Calibration Absolute Offset	FP	R/W	0.00
2635	A4B	A2 - Calibration Actual 1	FP	R/W	0.00
2637	A4D	A2 - Calibration Actual 2	FP	R/W	0.00

Analog Input 2 Calibration

Register (Decimal)	Register (Hex)	Description	Data Type	Access	Default
2639	A4F	A2 - Calibration Actual 3	FP	R/W	0.00
2641	A51	A2 - Calibration Actual 4	FP	R/W	0.00
2643	A53	A2 - Calibration Actual 5	FP	R/W	0.00
2645	A55	A2 - Calibration Actual 6	FP	R/W	0.00
2647	A57	A2 - Calibration Actual 7	FP	R/W	0.00
2649	A59	A2 - Calibration Actual 8	FP	R/W	0.00
2651	A5B	A2 - Calibration Actual 9	FP	R/W	0.00
2653	A5D	A2 - Calibration Actual 10	FP	R/W	0.00
2655	A5F	A2 - Calibration Actual 11	FP	R/W	0.00
2657	A61	A2 - Calibration Actual 12	FP	R/W	0.00
2659	A63	A2 - Calibration Measured 1	FP	R/W	0.00
2661	A65	A2 - Calibration Measured 2	FP	R/W	0.00
2663	A67	A2 - Calibration Measured 3	FP	R/W	0.00
2665	A69	A2 - Calibration Measured 4	FP	R/W	0.00
2667	A6B	A2 - Calibration Measured 5	FP	R/W	0.00
2669	A6D	A2 - Calibration Measured 6	FP	R/W	0.00
2671	A6F	A2 - Calibration Measured 7	FP	R/W	0.00
2673	A71	A2 - Calibration Measured 8	FP	R/W	0.00
2675	A73	A2 - Calibration Measured 9	FP	R/W	0.00
2677	A75	A2 - Calibration Measured 10	FP	R/W	0.00
2679	A77	A2 - Calibration Measured 11	FP	R/W	0.00
2681	A79	A2 - Calibration Measured 12	FP	R/W	0.00

¹ The Calibration Type register must be configured using ModWorX Pro. This register defines the type and number of calibration points used. If altered manually, calibration points must be entered in ascending order.

Digital Input Configuration

Register (Decimal)	Register (Hex)	Description	Data Type	Access	Default
2900	B54	Digital Mode	U16	R/W	0

Flow Run 1 Configuration

Register (Decimal)	Register (Hex)	Description	Data Type	Access	Default
3000	BB8	FR1 Volume Units See Units Table	U16	R/W	201
3001	BB9	FR1 Time Base	U16	R/W	3
3002	BBA	FR1 Flow Calculation Period (Number of seconds for each calculation)	U16	R/W	60
3003	BBB	FR1 Dampening Factor	U16	R/W	0

Flow Run 1 Configuration

Register (Decimal)	Register (Hex)	Description	Data Type	Access	Default
3004	BBC	FR1 Flow Rate Calculation (See definition.)	U16	R/W	0
3005	BBD	FR1 Override Enable 0 - Disabled 1 - Enabled	U16	R/W	0
3006	BBE	FR1 Fluid Properties (See definition.)	U16	R/W	3000
3007	BBF	FR1 Fluid Property Calculation (Number of flow rate calculation periods before each fluid property calculation)	U16	R/W	1
3008	BC0	FR1 Material Type: Pipe 0 - Stainless Steel (304/316) 1 - Carbon Steel 2 - Monel 3 - Brass 4 - Inconel 5 - Nickel 6 - HastC22 7 - Titanium	U16	R/W	1
3009	BC1	FR1 Material Type: Plate 0 - Stainless Steel (304/316) 1 - Carbon Steel 2 - Monel 3 - Brass 4 - Inconel 5 - Nickel 6 - HastC22 7 - Titanium	U16	R/W	0
3010	BC2	FR1 Tap Type (See definition.)	U16	R/W	0
3011	BC3	FR1 Static Pressure Selection	U16	R/W	8000
3012	BC4	FR1 Differential Pressure Selection	U16	R/W	8000
3013	BC5	FR1 Process Temperature Selection	U16	R/W	8000
3014	BC6	FR1 Turbine Source	U16	R/W	0
3015	BC7	FR1 Mass Units	U16	R/W	601
3016	BC8	FR1 Energy Units	U16	R/W	701
3017	BC9	FR1 Override Value	FP	R/W	0.00
3019	BCB	FR1 Fail Value	FP	R/W	0.00
3021	BCD	FR1 Low Flow Cutoff	FP	R/W	0.00
3023	BCF	FR1 Low Cutoff	FP	R/W	0.00
3025	BD1	FR1 Base Temperature	FP	R/W	60.00 Deg F
3027	BD3	FR1 Base Pressure	FP	R/W	14.73 psi
3029	BD5	FR1 Atmospheric Pressure	FP	R/W	14.73 psi
3031	BD7	FR1 Pipe Size	FP	R/W	2.067 in.

Flow Run 1 Configuration

Register (Decimal)	Register (Hex)	Description	Data Type	Access	Default
3033	BD9	FR1 Pipe Reference Temp	FP	R/W	68.00 Deg F
3035	BDB	FR1 Plate Size	FP	R/W	1.00 in.
3037	BDD	FR1 Plate Reference Temp	FP	R/W	68.00 Deg F
3039	BDF	FR1 Isentropic Exponent - k	FP	R/W	1.30
3041	BE1	FR1 Viscosity	FP	R/W	0.010268 cP
3043	BE3	FR1 Cone Beta	FP	R/W	0.500
3045	BE5	FR1 Cone Flow Coefficient	FP	R/W	1.000
3047	BE7	FR1 Low Pressure Cutoff	FP	R/W	1.000 ln H2O
3049	BE9	FR1 Specific Gravity	FP	R/W	0.60
3051	BEB	FR1 Heating Value	FP	R/W	1031.426
3053	BED	FR1 Gas Fraction/Quality	FP	R/W	1.00
3055	BEF	FR1 Configuration Parameter 1 (Absolute Density - Liquids) Liquid Density Base Fluid = Liquid : Base Density Fluid = Ngas : Liquid Oil Density Base	FP	R/W	53.06376
3057	BF1	FR1 Configuration Parameter 2 Fluid = Liquid : Flowing Density Fluid = NGas : Base liquid water density	FP	R/W	62.30385
3059	BF3	FR1 Configuration Parameter 3 Oil Fraction	FP	R/W	1.00
3061	BF5	FR1 Configuration Parameter 4	FP	R/W	0.00
3063	BF7	FR1 GC - Methane (C1)	FP	R/W	0.965222
3065	BF9	FR1 GC - Nitrogen (N2)	FP	R/W	0.002595
3067	BFB	FR1 GC - Carbon Dioxide (CO2)	FP	R/W	0.005956
3069	BFD	FR1 GC - Ethane (C2)	FP	R/W	0.018186
3071	BFF	FR1 GC - Propane (C3)	FP	R/W	0.004596
3073	C01	FR1 GC - Water (H2O)	FP	R/W	0.00
3075	C03	FR1 GC - Hydrogen Sulfide (H2S)	FP	R/W	0.00
3077	C05	FR1 GC - Hydrogen (H2)	FP	R/W	0.00
3079	C07	FR1 GC - Carbon Monoxide (CO)	FP	R/W	0.00
3081	C09	FR1 GC - Oxygen (O2)	FP	R/W	0.00
3083	C0B	FR1 GC - I-Butane (i-C4)	FP	R/W	0.000977
3085	C0D	FR1 GC - N-Butane (n-C4)	FP	R/W	0.001007
3087	C0F	FR1 GC - I-Pentane (i-C5)	FP	R/W	0.000473
3089	C11	FR1 GC - N-Pentane (n-C5)	FP	R/W	0.000324
3091	C13	FR1 GC - N-Hexane (n-C6)	FP	R/W	0.000664
3093	C15	FR1 GC - N-Heptane (n-C7)	FP	R/W	0.00
3095	C17	FR1 GC - N-Octane (n-C8)	FP	R/W	0.00
3097	C19	FR1 GC - N-Nonane (n-C9)	FP	R/W	0.00

Flow Run 1 Configuration

Register (Decimal)	Register (Hex)	Description	Data Type	Access	Default
3099	C1B	FR1 GC - N-Decane (n-C10)	FP	R/W	0.00
3101	C1D	FR1 GC - Helium (He)	FP	R/W	0.00
3103	C1F	FR1 GC - Argon (Ar)	FP	R/W	0.00
3105	C21	FR1 Unit Scale	FP	R/W	1.00
3107	C23	FR1 Unit Offset	FP	R/W	0.00
3109	C25	FR1 Unit Description 1	LCD	R/W	—
3110	C26	FR1 Unit Description 2	LCD	R/W	—
3111	C27	FR1 Unit Description 3	LCD	R/W	—
3112	C28	FR1 Mass Scale	FP	R/W	1.00
3114	C2A	FR1 Mass Description 1	LCD	R/W	—
3115	C2B	FR1 Mass Description 2	LCD	R/W	—
3116	C2C	FR1 Mass Description 3	LCD	R/W	—
3117	C2D	FR1 Energy Scale	FP	R/W	1.00
3119	C2F	FR1 Energy Description 1	LCD	R/W	—
3120	C30	FR1 Energy Description 2	LCD	R/W	—
3121	C31	FR1 Energy Description 3	LCD	R/W	—

Flow Rate Calculation Register

The flow rate calculation register is shown below.

15	14	13	12	11	10	9	8	7	6	5	4	3	2	1	0
			LE	Wet Correction								Flow Rate Calculation			

LE - Liquid Estimation Selection (STEAM ONLY)	
0	Do not include Liquid Estimate
1	Include Liquid Estimate
Wet Correction	
0	No Wet Correction
1	Orifice – Chisholm
2	Orifice - James (STEAM ONLY)
3	Cone - Steven
4	Venturi - de Leeuw correlation (beta = 0.401 only) (FUTURE)
5	Venturi - Steven correlation (beta = 0.55 only) (FUTURE)
Flow Rate Calculation	
0	AGA-3 1992
1	Cone Spool
2	Cone Wafer
3	AGA-7
4	ISO-5167 - Orifice
5	ISO-5167 Venturi Nozzle (FUTURE)

Flow Rate Calculation	
6	ISA Nozzle (FUTURE)
7	Long Radius Nozzle (FUTURE)
8	Averaging Pitot Tube (Annubar®)

Fluid Property Register

15	14	13	12	11	10	9	8	7	6	5	4	3	2	1	0
HV	SG	V	Isen	LiqDC			GPA		HVRef						Fluid Property Calc

HV - Heating Value Selection	
0	Calculated
1	Manual Entry
SG - Specific Gravity Selection	
0	Calculated
1	Manual Entry
V - Viscosity Selection	
0	Calculated
1	Manual Entry
Isen - Isentropic Exponent Selection	
0	Calculated
1	Manual Entry
LiqDC – Liquid Density Control	
0	For Liquids: Register 3057 contains the flowing density For NGas: Register 3057 contains the base liquid oil density
1	For Liquids: Register 3057 contains the coefficient of thermal expansion For NGas: Register 3057 contains the flowing liquid oil density
GPA - GPA Table Selection	
0	Use 2008 Table
1	Use 1996 Table
HVRef - Heating Value Reference	
0	US (AGA) – 14.73 psi, 60 Deg F
1	Canada, UK – 103.208 kPa, 15 Deg C
2	Brazil (FUTURE)
3	France (FUTURE)
Fluid Property Calculation	
0	AGA-8 Detail
1	AGA-8 Gross
2	(FUTURE)
3	IF-97 (STEAM ONLY)
4	IF-97/James - (STEAM ONLY)
5-15	(FUTURE)
16	Generic Liquid (API 2145 Table 6C)

Fluid Property Calculation	
17	Crude Oil
18	Gasolines
19	Jet Fuels
20	Fuel Oils
21	Lube Oils

Tap Type Register

15	14	13	12	11	10	9	8	7	6	5	4	3	2	1	0	
												Loc	Tap Type			

Loc (Pressure Tap Location)	
0	Upstream
1	Downstream

Tap Type	
0	Flange
1	Corner
2	D and D/2
3	Reserved
4	Reserved
5	Reserved
6	Reserved
7	Reserved

Flow Run 1 Calibration

Register (Decimal)	Register (Hex)	Description	Data Type	Access	Default
3200	C80	FR1 Calibration Type ¹	U16	R/W	200
3201	C81	FR1 Nominal Flow Coefficient	FP	R/W	0.88
3203	C83	FR1 Coefficient Offset	FP	R/W	0.00
3205	C85	FR1 Flow Coefficient 1	FP	R/W	0.88
3207	C87	FR1 Flow Coefficient 2	FP	R/W	0.00
3209	C89	FR1 Flow Coefficient 3	FP	R/W	0.00
3211	C8B	FR1 Flow Coefficient 4	FP	R/W	0.00
3213	C8D	FR1 Flow Coefficient 5	FP	R/W	0.00
3215	C8F	FR1 Flow Coefficient 6	FP	R/W	0.00
3217	C91	FR1 Flow Coefficient 7	FP	R/W	0.00
3219	C93	FR1 Flow Coefficient 8	FP	R/W	0.00
3221	C95	FR1 Flow Coefficient 9	FP	R/W	0.00
3223	C97	FR1 Flow Coefficient 10	FP	R/W	0.00
3225	C99	FR1 Flow Coefficient 11	FP	R/W	0.00
3227	C9B	FR1 Flow Coefficient 12	FP	R/W	0.00
3229	C9D	FR1 Flow Coefficient 13	FP	R/W	0.00
3231	C9F	FR1 Flow Coefficient 14	FP	R/W	0.00

Flow Run 1 Calibration

Register (Decimal)	Register (Hex)	Description	Data Type	Access	Default
3233	CA1	FR1 Flow Coefficient 15	FP	R/W	0.00
3235	CA3	FR1 Flow Coefficient 16	FP	R/W	0.00
3237	CA5	FR1 Reynolds Number 1	FP	R/W	1.00
3239	CA7	FR1 Reynolds Number 2	FP	R/W	0.00
3241	CA9	FR1 Reynolds Number 3	FP	R/W	0.00
3243	CAB	FR1 Reynolds Number 4	FP	R/W	0.00
3245	CAD	FR1 Reynolds Number 5	FP	R/W	0.00
3247	CAF	FR1 Reynolds Number 6	FP	R/W	0.00
3249	CB1	FR1 Reynolds Number 7	FP	R/W	0.00
3251	CB3	FR1 Reynolds Number 8	FP	R/W	0.00
3253	CB5	FR1 Reynolds Number 9	FP	R/W	0.00
3255	CB7	FR1 Reynolds Number 10	FP	R/W	0.00
3257	CB9	FR1 Reynolds Number 11	FP	R/W	0.00
3259	CBB	FR1 Reynolds Number 12	FP	R/W	0.00
3261	CBD	FR1 Reynolds Number 13	FP	R/W	0.00
3263	CBF	FR1 Reynolds Number 14	FP	R/W	0.00
3265	CC1	FR1 Reynolds Number 15	FP	R/W	0.00
3267	CC3	FR1 Reynolds Number 16	FP	R/W	0.00

¹ The Calibration Type register must be configured using ModWorX Pro. This register defines the type and number of calibration points used. If altered manually, calibration points must be entered in ascending order.

Output Configuration

Register (Decimal)	Register (Hex)	Description	Data Type	Access	Default
4000	FA0	Pulse Out 1 - Source	U16	R/W	16384
4001	FA1	Pulse Out 1 - Duration	U16	R/W	10
4002	FA2	Pulse Out 1 - Decimal Location	U16	R/W	2
4003	FA3	Pulse Out 1 - Data Pointer	U16	R/W	108
4004	FA4	Pulse Out 1 - Scale Factor	FP	R/W	1
4006	FA6	Pulse Out 1 - Low Level	FP	R/W	0
4008	FA8	Pulse Out 1 - High Level	FP	R/W	0
4010 to 4039	Reserved				
4040	FC8	Analog Out 1 - Source	U16	R/W	0
4041	FC9	Analog Out 1 - Low Value	FP	R/W	0
4043	FCB	Analog Out 1 - High Value	FP	R/W	1700
4045	FCD	Analog Out 1 - Low Adjust	U16	R/W	32768
4046	FCE	Analog Out 1 - High Adjust	U16	R/W	32768
4047	FCF	Analog Out 2 - Source	U16	R/W	0
4048	FD0	Analog Out 2 - Low Value	FP	R/W	0
4050	FD2	Analog Out 2 - High Value	FP	R/W	1700
4052	FD4	Analog Out 2 - Low Adjust	U16	R/W	0

Output Configuration

Register (Decimal)	Register (Hex)	Description	Data Type	Access	Default
4053	FD5	Analog Out 2 - High Adjust	U16	R/W	4095
4054	FD6	Analog Out 3 - Source	U16	R/W	0
4055	FD7	Analog Out 3 - Low Value	FP	R/W	0
4057	FD9	Analog Out 3 - High Value	FP	R/W	1700
4059	FDB	Analog Out 3 - Low Adjust	U16	R/W	0
4060	FDC	Analog Out 3 - High Adjust	U16	R/W	4095
4061	FDD	Analog Out 4 - Source	U16	R/W	0
4062	FDE	Analog Out 4 - Low Value	FP	R/W	0
4064	FE0	Analog Out 4 - High Value	FP	R/W	1700
4066	FE2	Analog Out 4 - Low Adjust	U16	R/W	0
4067	FE3	Analog Out 4 - High Adjust	U16	R/W	4095

Pulse Input for Status Indication

While the pulse input on the expansion board can be configured to provide the frequency input for Turbine Input 2 (see Turbine 2 Configuration, page C-10), the pulse input can also be used to indicate the status of a switch. When used for status indication, no configuration is required in ModWorX Pro. Status is derived from a simple read of the pulse input “state” and “count” registers (8624 and 8626). If no voltage is present, register 8624 will read “1”; if voltage is applied, register 8624 will read “0”. Each time the “state” goes from “1” to “0,” the value in the “count” register increments. By monitoring the “state” and “count” registers, the user can determine whether a switch is on or off, and how many times the switch has turned on or off in a given time period.

A user clears the count by writing a “0” to register 8626.

Holding Registers

Register (Decimal)	Register (Hex)	Description	Data Type	Access
8000	1F40	Interval Pointer	FP	RO
8002	1F42	Daily Pointer	FP	RO
8004	1F44	Event Counter	FP	RO
8006	1F46	Real Date	FP	RO
8008	1F48	Real Time	FP	RO
8010	1F4A	Flow Run Alarms	FP	RO
8012	1F4C	Flow Run Alarm Low	FP	RO
8014	1F4E	Flow Run Alarm High	FP	RO
8016	1F50	Diagnostic 1	FP	RO
8018	1F52	Diagnostic 2	FP	RO
8020	1F54	Diagnostic 3	FP	RO
8022	1F56	Diagnostic 4	FP	RO
8024	1F58	Polling Index	FP	RO
8026	1F5A	FR1 Grand Total	FP	RO

Holding Registers

Register (Decimal)	Register (Hex)	Description	Data Type	Access
8028	1F5C	FR1 Instantaneous Flow Rate	FP	RO
8030	1F5E	FR1 Daily Total	FP	RO
8032	1F60	FR1 Interval Total	FP	RO
8034	1F62	FR1 Polling Total	FP	RO
8036	1F64	FR1 Previous Day Total	FP	RO
8038	1F66	FR1 Previous Interval	FP	RO
8040	1F68	FR1 Previous Polling Total	FP	RO
8042	1F6A	FR1 Grand Mass Total	FP	RO
8044	1F6C	FR1 Instantaneous Mass Flow Rate	FP	RO
8046	1F6E	FR1 Daily Mass Total	FP	RO
8048	1F70	FR1 Interval Mass Total	FP	RO
8050	1F72	FR1 Polling Mass Total	FP	RO
8052	1F74	FR1 Previous Day Mass	FP	RO
8054	1F76	FR1 Previous Interval Mass	FP	RO
8056	1F78	FR1 Previous Polling Mass	FP	RO
8058	1F7A	FR1 Grand Energy Total	FP	RO
8060	1F7C	FR1 Instantaneous Energy Flow Rate	FP	RO
8062	1F7E	FR1 Daily Energy Total	FP	RO
8064	1F80	FR1 Interval Energy Total	FP	RO
8066	1F82	FR1 Polling Energy Total	FP	RO
8068	1F84	FR1 Previous Day Energy	FP	RO
8070	1F86	FR1 Previous Interval Energy	FP	RO
8072	1F88	FR1 Previous Polling Energy	FP	RO
8074	1F8A	FR1 Daily Estimated Total	FP	RO
8076	1F8C	FR1 Monthly Total	FP	RO
8078	1F8E	FR1 Previous Month Total	FP	RO
8080	1F90	FR1 Daily Run Time	FP	RO
8082	1F92	FR1 Interval Run Time	FP	RO
8084	1F94	FR1 Polling Run Time	FP	RO
8086	1F96	FR1 Previous Daily Run Time	FP	RO
8088	1F98	FR1 Previous Interval Run Time	FP	RO
8090	1F9A	FR1 Previous Polling Run Time	FP	RO
8092	1F9C	FR1 Static Pressure	FP	RO
8094	1F9E	FR1 Differential Pressure	FP	RO
8096	1FA0	FR1 Process Temperature	FP	RO
8098	1FA2	FR1 UnCorrected Volume	FP	RO
8100	1FA4	FR1 SqrtDP	FP	RO
8102	1FA6	FR1 Compressibility (Natural Gas); FR1 Compression Factor (Liquids)	FP	RO
8104	1FA8	FR1 Density	FP	RO
8106	1FAA	FR1 Base Compressibility	FP	RO

Holding Registers

Register (Decimal)	Register (Hex)	Description	Data Type	Access
8108	1FAC	FR1 Base Density	FP	RO
8110	1FAE	FR1 Average Molecular Weight	FP	RO
8112	1FB0	FR1 Molar Fraction Sum	FP	RO
8114	1FB2	FR1 Mass Heating Value	FP	RO
8116	1FB4	FR1 Heating Value Volume Basis	FP	RO
8118	1FB6	FR1 Specific Gravity	FP	RO
8120	1FB8	FR1 Viscosity	FP	RO
8122	1FBA	FR1 Isentropic Exponent	FP	RO
8124	1FBC	FR1 Reynolds Number	FP	RO
8126	1FBE	FR1 Calculation Parameter 1	FP	RO
8128	1FC0	FR1 Calculation Parameter 2	FP	RO
8130	1FC2	FR1 Calculation Parameter 3	FP	RO
8132	1FC4	FR1 Calculation Parameter 4	FP	RO
8134	1FC6	FR1 Calculation Parameter 5	FP	RO
8136	1FC8	FR1 Calculation Parameter 6	FP	RO
8138	1FCA	FR1 Calculation Parameter 7	FP	RO
8140	1FCC	FR1 Calculation Parameter 8	FP	RO
8142	1FCE	FR1 Calculation Parameter 9	FP	RO
8144	1FD0	FR1 Calculation Parameter 10	FP	RO
8146	1FD2	FR1 Calculation Parameter 11	FP	RO
8148	1FD4	FR1 Calculation Parameter 12	FP	RO
8150	1FD6	FR1 Calculation Parameter 13	FP	RO
8152	1FD8	FR1 Calculation Parameter 14	FP	RO
8154	1FDA	FR1 Calculation Parameter 15	FP	RO
8156	1FDC	FR1 Calculation Parameter 16	FP	RO
8158	1FDE	FR1 Grand Total [MCF]	FP	RO
8160	1FE0	FR1 Instantaneous Flow Rate [MCF]	FP	RO
8162	1FE2	FR1 Daily Total [MCF]	FP	RO
8164	1FE4	FR1 Interval Total [MCF]	FP	RO
8166	1FE6	FR1 Polling Total [MCF]	FP	RO
8168	1FE8	FR1 Previous Day [MCF]	FP	RO
8170	1FEA	FR1 Previous Interval [MCF]	FP	RO
8172	1FEC	FR1 Previous Polling Total [MCF]	FP	RO
8174	1FEE	FR1 Grand Mass Total [LBM]	FP	RO
8176	1FF0	FR1 Instantaneous Mass Rate [LBM]	FP	RO
8178	1FF2	FR1 Daily Mass Total [LBM]	FP	RO
8180	1FF4	FR1 Interval Mass Total [LBM]	FP	RO
8182	1FF6	FR1 Polling Mass Total [LBM]	FP	RO
8184	1FF8	FR1 Previous Day Mass [LBM]	FP	RO
8186	1FFA	FR1 Previous Interval Mass [LBM]	FP	RO
8188	1FFC	FR1 Previous Polling Mass [LBM]	FP	RO

Holding Registers

Register (Decimal)	Register (Hex)	Description	Data Type	Access
8190	1FFE	FR1 Grand Energy Total [MMBTU]	FP	RO
8192	2000	FR1 Instantaneous Energy Rate [MMBTU]	FP	RO
8194	2002	FR1 Daily Energy Total [MMBTU]	FP	RO
8196	2004	FR1 Interval Energy Total [MMBTU]	FP	RO
8198	2006	FR1 Polling Energy Total [MMBTU]	FP	RO
8200	2008	FR1 Previous Day Energy [MMBTU]	FP	RO
8202	200A	FR1 Previous Interval Energy [MMBTU]	FP	RO
8204	200C	FR1 Previous Polling Energy [MMBTU]	FP	RO
8206	200E	FR1 Daily Estimated Total [MCF]	FP	RO
8208	2010	FR1 Monthly Total [MCF]	FP	RO
8210	2012	FR1 Previous Month Total [MCF]	FP	RO
8212	2014	FR1 Mass Heating Value [BASE]	FP	RO
8214	2016	FR1 Volumetric Heating Value [BASE]	FP	RO
8216	2018	T1 Grand Total	FP	RO
8218	201A	T1 Instantaneous Flow Rate	FP	RO
8220	201C	T1 Daily Total	FP	RO
8222	201E	T1 Interval Total	FP	RO
8224	2020	T1 Polling Total	FP	RO
8226	2022	T1 Previous Day	FP	RO
8228	2024	T1 Previous Interval	FP	RO
8230	2026	T1 Previous Polling Total	FP	RO
8232	2028	T1 Daily Estimated Total	FP	RO
8234	202A	T1 Monthly Total	FP	RO
8236	202C	T1 Previous Month Total	FP	RO
8238	202E	T1 Daily Run Time	FP	RO
8240	2030	T1 Interval Run Time	FP	RO
8242	2032	T1 Polling Run Time	FP	RO
8244	2034	T1 Previous Daily Run Time	FP	RO
8246	2036	T1 Previous Interval Run Time	FP	RO
8248	2038	T1 Previous Polling Run Time	FP	RO
8250	203A	T1 Grand Total [GAL]	FP	RO
8252	203C	T1 Instantaneous Flow Rate [GAL]	FP	RO
8254	203E	T1 Daily Total [GAL]	FP	RO
8256	2040	T1 Interval Total [GAL]	FP	RO
8258	2042	T1 Polling Total [GAL]	FP	RO
8260	2044	T1 Previous Day [GAL]	FP	RO
8262	2046	T1 Previous Interval [GAL]	FP	RO
8264	2048	T1 Previous Polling Total [GAL]	FP	RO
8266	204A	T1 Daily Estimated Total [GAL]	FP	RO
8268	204C	T1 Monthly Total [GAL]	FP	RO

Holding Registers

Register (Decimal)	Register (Hex)	Description	Data Type	Access
8270	204E	T1 Previous Month Total [GAL]	FP	RO
8272	2050	T1 Frequency	FP	RO
8274	2052	T1 Active K-Factor	FP	RO
8276	2054	T2 Grand Total	FP	RO
8278	2056	T2 Instantaneous Flow Rate	FP	RO
8280	2058	T2 Daily Total	FP	RO
8282	205A	T2 Interval Total	FP	RO
8284	205C	T2 Polling Total	FP	RO
8286	205E	T2 Previous Day	FP	RO
8288	2060	T2 Previous Interval	FP	RO
8290	2062	T2 Previous Polling Total	FP	RO
8292	2064	T2 Daily Estimated Total	FP	RO
8294	2066	T2 Monthly Total	FP	RO
8296	2068	T2 Previous Month Total	FP	RO
8298	206A	T2 Daily Run Time	FP	RO
8300	206C	T2 Interval Run Time	FP	RO
8302	206E	T2 Polling Run Time	FP	RO
8304	2070	T2 Previous Daily Run Time	FP	RO
8306	2072	T2 Previous Interval Run Time	FP	RO
8308	2074	T2 Previous Polling Run Time	FP	RO
8310	2076	T2 Grand Total [GAL]	FP	RO
8312	2078	T2 Instantaneous Flow Rate [GAL]	FP	RO
8314	207A	T2 Daily Total [GAL]	FP	RO
8316	207C	T2 Interval Total [GAL]	FP	RO
8318	207E	T2 Polling Total [GAL]	FP	RO
8320	2080	T2 Previous Day Total [GAL]	FP	RO
8322	2082	T2 Previous Interval [GAL]	FP	RO
8324	2084	T2 Previous Polling Total [GAL]	FP	RO
8326	2086	T2 Daily Estimated Total [GAL]	FP	RO
8328	2088	T2 Monthly Total [GAL]	FP	RO
8330	208A	T2 Previous Month Total [GAL]	FP	RO
8332	208C	T2 Frequency	FP	RO
8334	208E	T2 Active K-Factor	FP	RO
8336	2090	SP Instantaneous Reading	FP	RO
8338	2092	SP Rate Of Change	FP	RO
8340	2094	SP Daily Average	FP	RO
8342	2096	SP Interval Average	FP	RO
8344	2098	SP Polling Average	FP	RO
8346	209A	SP Previous Daily Average	FP	RO
8348	209C	SP Previous Interval Average	FP	RO
8350	209E	SP Previous Polling Average	FP	RO

Holding Registers

Register (Decimal)	Register (Hex)	Description	Data Type	Access
8352	20A0	SP Daily Run Time	FP	RO
8354	20A2	SP Interval Run Time	FP	RO
8356	20A4	SP Polling Run Time	FP	RO
8358	20A6	SP Previous Daily Run Time	FP	RO
8360	20A8	SP Previous Interval Run Time	FP	RO
8362	20AA	SP Previous Polling Run Time	FP	RO
8364	20AC	SP Instantaneous Reading [PSI]	FP	RO
8366	20AE	SP Rate of Change [PSI]	FP	RO
8368	20B0	SP Daily Average [PSI]	FP	RO
8370	20B2	SP Interval Average [PSI]	FP	RO
8372	20B4	SP Polling Average [PSI]	FP	RO
8374	20B6	SP Previous Daily Average [PSI]	FP	RO
8376	20B8	SP Previous Interval Average [PSI]	FP	RO
8378	20BA	SP Previous Polling Average [PSI]	FP	RO
8380	20BC	DP Instantaneous Reading	FP	RO
8382	20BE	DP Rate Of Change	FP	RO
8384	20C0	DP Daily Average	FP	RO
8386	20C2	DP Interval Average	FP	RO
8388	20C4	DP Polling Average	FP	RO
8390	20C6	DP Previous Daily Average	FP	RO
8392	20C8	DP Previous Interval Average	FP	RO
8394	20CA	DP Previous Polling Average	FP	RO
8396	20CC	DP Daily Run Time	FP	RO
8398	20CE	DP Interval Run Time	FP	RO
8400	20D0	DP Polling Run Time	FP	RO
8402	20D2	DP Previous Daily Run Time	FP	RO
8404	20D4	DP Previous Interval Run Time	FP	RO
8406	20D6	DP Previous Polling Run Time	FP	RO
8408	20D8	DP Instantaneous Reading [INH2O]	FP	RO
8410	20DA	DP Rate of Change [INH2O]	FP	RO
8412	20DC	DP Daily Average [INH2O]	FP	RO
8414	20DE	DP Interval Average [INH2O]	FP	RO
8416	20E0	DP Polling Average [INH2O]	FP	RO
8418	20E2	DP Previous Daily Average [INH2O]	FP	RO
8420	20E4	DP Previous Interval Average [INH2O]	FP	RO
8422	20E6	DP Previous Polling Average [INH2O]	FP	RO
8424	20E8	PT Instantaneous Reading	FP	RO
8426	20EA	PT Rate Of Change	FP	RO
8428	20EC	PT Daily Average	FP	RO
8430	20EE	PT Interval Average	FP	RO
8432	20F0	PT Polling Average	FP	RO

Holding Registers

Register (Decimal)	Register (Hex)	Description	Data Type	Access
8434	20F2	PT Previous Daily Average	FP	RO
8436	20F4	PT Previous Interval Average	FP	RO
8438	20F6	PT Previous Polling Average	FP	RO
8440	20F8	PT Daily Run Time	FP	RO
8442	20FA	PT Interval Run Time	FP	RO
8444	20FC	PT Polling Run Time	FP	RO
8446	20FE	PT Previous Daily Run Time	FP	RO
8448	2100	PT Previous Interval Run Time	FP	RO
8450	2102	PT Previous Polling Run Time	FP	RO
8452	2104	PT Instantaneous Reading [DEGF]	FP	RO
8454	2106	PT Rate of Change [DEGF]	FP	RO
8456	2108	PT Daily Average [DEGF]	FP	RO
8458	210A	PT Interval Average [DEGF]	FP	RO
8460	210C	PT Polling Average [DEGF]	FP	RO
8462	210E	PT Previous Daily Average [DEGF]	FP	RO
8464	2110	PT Previous Interval Average [DEGF]	FP	RO
8466	2112	PT Previous Polling Average [DEGF]	FP	RO
8468	2114	A1 Instantaneous Reading	FP	RO
8470	2116	A1 Rate Of Change	FP	RO
8472	2118	A1 Daily Average	FP	RO
8474	211A	A1 Interval Average	FP	RO
8476	211C	A1 Polling Average	FP	RO
8478	211E	A1 Previous Daily Average	FP	RO
8480	2120	A1 Previous Interval Average	FP	RO
8482	2122	A1 Previous Polling Average	FP	RO
8484	2124	A1 Daily Run Time	FP	RO
8486	2126	A1 Interval Run Time	FP	RO
8488	2128	A1 Polling Run Time	FP	RO
8490	212A	A1 Previous Daily Run Time	FP	RO
8492	212C	A1 Previous Interval Run Time	FP	RO
8494	212E	A1 Previous Polling Run Time	FP	RO
8496	2130	A1 Instantaneous Reading [VOLT]	FP	RO
8498	2132	A1 Rate of Change [VOLT]	FP	RO
8500	2134	A1 Daily Average [VOLT]	FP	RO
8502	2136	A1 Interval Average [VOLT]	FP	RO
8504	2138	A1 Polling Average [VOLT]	FP	RO
8506	213A	A1 Previous Daily Average [VOLT]	FP	RO
8508	213C	A1 Previous Interval Average [VOLT]	FP	RO
8510	213E	A1 Previous Polling Average [VOLT]	FP	RO
8512	2140	A2 Instantaneous Reading	FP	RO
8514	2142	A2 Rate Of Change	FP	RO

Holding Registers

Register (Decimal)	Register (Hex)	Description	Data Type	Access
8516	2144	A2 Daily Average	FP	RO
8518	2146	A2 Interval Average	FP	RO
8520	2148	A2 Polling Average	FP	RO
8522	214A	A2 Previous Daily Average	FP	RO
8524	214C	A2 Previous Interval Average	FP	RO
8526	214E	A2 Previous Polling Average	FP	RO
8528	2150	A2 Daily Run Time	FP	RO
8530	2152	A2 Interval Run Time	FP	RO
8532	2154	A2 Polling Run Time	FP	RO
8534	2156	A2 Previous Daily Run Time	FP	RO
8536	2158	A2 Previous Interval Run Time	FP	RO
8538	215A	A2 Previous Polling Run Time	FP	RO
8540	215C	A2 Instantaneous Reading [VOLT]	FP	RO
8542	215E	A2 Rate of Change [VOLT]	FP	RO
8544	2160	A2 Daily Average [VOLT]	FP	RO
8546	2162	A2 Interval Average [VOLT]	FP	RO
8548	2164	A2 Polling Average [VOLT]	FP	RO
8550	2166	A2 Previous Daily Average [VOLT]	FP	RO
8552	2168	A2 Previous Interval Average [VOLT]	FP	RO
8554	216A	A2 Previous Polling Average [VOLT]	FP	RO
8556	216C	Internal Temperature	FP	RO
8558	216E	Supply Voltage	FP	RO
8560	2170	Battery Voltage	FP	RO
8562	2172	Live FR1 Instantaneous Flow Rate [BASE]	FP	RO
8564		Reserved		
8566	2176	Live T1 Instantaneous Flow Rate [GAL]	FP	RO
8568	2178	Live T2 Instantaneous Flow Rate [GAL]	FP	RO
8570	217A	Live Turbine Frequency Differential	FP	RO
8572	217C	Live Turbine Frequency Ratio	FP	RO
8574	217E	Live Static Pressure	FP	RO
8576	2180	Live Differential Pressure	FP	RO
8578	2182	Live MVT Temperature	FP	RO
8580	2184	Live Bridge Voltage	FP	RO
8582	2186	Live Analog 1	FP	RO
8584	2188	Live Analog 2	FP	RO
8586	218A	Live Production Temperature	FP	RO
8588	218C	Live RTD Resistance	FP	RO
8590	218E	PID Stage 1 Status	FP	RO
8592	2190	PID Stage 1 Output	FP	RO
8594	2192	PID Stage 2 Status	FP	RO

Holding Registers

Register (Decimal)	Register (Hex)	Description	Data Type	Access
8596	2194	PID Stage 2 Output	FP	RO
8598	2196	PO1 Pulses	FP	RO
8600 to 8605	Reserved			
8606	219E	AO1 Output Current	FP	RO
8608	21A0	AO2 Output Current	FP	RO
8610	21A2	AO3 Output Current	FP	RO
8612	21A4	AO4 Output Current	FP	RO
8614	21A6	AO1 DAC Output	FP	RO
8616	21A8	AO2 DAC Output	FP	RO
8618	21AA	AO3 DAC Output	FP	RO
8620	21AC	AO4 DAC Output	FP	RO
8622 to 8625	Reserved			
8626	21B2	PI2 State	FP	RO
8628	21B4	PI2 Count	FP	RO
8630 to 8637	Reserved			
8638	21BE	Daily Archive Date	FP	RO
8640	21C0	Interval Archive Date	FP	RO
8642	21C2	Daily Archive Time	FP	RO
8644	21C4	Interval Archive Time	FP	RO
8646	21C6	Slave Data Point 01	FP	RO
8648	21C8	Slave Data Point 02	FP	RO
8650	21CA	Slave Data Point 03	FP	RO
8652	21CC	Slave Data Point 04	FP	RO
8654	21CE	Slave Data Point 05	FP	RO
8656	21D0	Slave Data Point 06	FP	RO
8658	21D2	Slave Data Point 07	FP	RO
8660	21D4	Slave Data Point 08	FP	RO
8662	21D6	Slave Data Point 09	FP	RO
8664	21D8	Slave Data Point 10	FP	RO
8666	21DA	Slave Data Point 11	FP	RO
8668	21DC	Slave Data Point 12	FP	RO
8670	21DE	Slave Data Point 13	FP	RO
8672	21E0	Slave Data Point 14	FP	RO
8674	21E2	Slave Data Point 15	FP	RO
8676	21E4	Slave Data Point 16	FP	RO

Flow Calculation Parameter Registers (1-16)

The Flow Calculation Parameter Registers definition is dependent upon the flow rate calculation method that is implemented. The following table describes the function of each of these registers for each of the supported calculation methods.

Reg. Num	AGA-3	ISO-5167	Cone –Spool Cone -Wafer	AGA-7
1	Pipe Size (Corrected)	Pipe Size (Corrected)	Pipe Size (Corrected)	Pipe Size (Corrected)
2	Plate Size (Corrected)	Plate Size (Corrected)	Plate Size (Corrected)	Temperature Ratio
3	Beta (Corrected)	Beta (Corrected)	Beta (Corrected)	Pressure Ratio
4	Plate Size (configured)	Plate Size (configured)	Plate Size (configured)	Supercompressibility
5	Stability Index	Stability Index	Stability Index	<Reserved>
6	Y	Y	Y	<Reserved>
7	Cd	Cd	Cd	<Reserved>
8	Ev	Ev	Ev	<Reserved>
9	Flow Extension (sqrt["H20*lbm/cf3])	Flow Extension (sqrt[pa*kg/m3])	Flow Extension (sqrt[pa*kg/m3])	<Reserved>
10	Flowing Density (kg/m3)	Flowing Density (kg/m3)	Flowing Density (kg/m3)	Flowing Density (kg/m3)
11	Quality (Vapor Liquid Fraction)	Quality (Vapor Liquid Fraction)	Quality (Vapor Liquid Fraction)	<Reserved>
12	Liquid Heating Value	Liquid Heating Value	Liquid Heating Value	<Reserved>
13	Liquid Flowing Density	Liquid Flowing Density	Liquid Flowing Density	<Reserved>
14	Estimated Liquid Mass Flow Rate	Estimated Liquid Mass Flow Rate	Estimated Liquid Mass Flow Rate	<Reserved>
15	Apparent Mass Flow Rate	Apparent Mass Flow Rate	Apparent Mass Flow Rate	Apparent Mass Flow Rate
16	Lockhart-Martinelli	Lockhart-Martinelli	Lockhart-Martinelli	<Reserved>

Base Units/Configured Units

The holding registers allow users to read data in terms of *configured* units of measurement and *base* units. The configured units follow the settings based on the Unit setting register and the unit scale and offset registers. The base units will always have the same unit of measurement independent of the unit, scale and offset settings. Also note that the log data is always in terms of base units. It is recommended to configure the units of measurement using the software.

Polling Registers

The Scanner 2000 stores volumes, averaged values, and flow times since the last polling sequence in a set of polling registers. Additionally, the instrument stores the number of polls requested in the polling index.

The polling sequence is started by writing a value of 20,000 to the Control Register. This transfers the polling totals, averages, and run times to the previous polling registers, increments the polling index and resets the polling totals, averages and run-time registers. Note that the polling registers are displayed in base units and configured units.

Interval/Daily/Event Pointer Registers

These registers provide an index of the last record that was stored in the log data. These values start at 1 and increment with each newly created log. When the maximum number of records is reached, the pointer resets to 1 and starts incrementing again.

Holding Registers (32-bit)

Register (Decimal)	Register (Hex)	Description	Data Type	Access
7000	1B58	Interval Pointer	FP	RO
7001	1B59	Daily Pointer	FP	RO
7002	1B5A	Event Counter	FP	RO
7003	1B5B	Real Date	FP	RO
7004	1B5C	Real Time	FP	RO
7005	1B5D	Flow Run Alarms	FP	RO
7006	1B5E	Flow Run Alarm Low	FP	RO
7007	1B5F	Flow Run Alarm High	FP	RO
7008	1B60	Diagnostic 1	FP	RO
7009	1B61	Diagnostic 2	FP	RO
7010	1B62	Diagnostic 3	FP	RO
7011	1B63	Diagnostic 4	FP	RO
7012	1B64	Polling Index	FP	RO
7013	1B65	FR1 Grand Volume Total	FP	RO
7014	1B66	FR1 Instantaneous Flow Rate	FP	RO
7015	1B67	FR1 Daily Total	FP	RO
7016	1B68	FR1 Interval Total	FP	RO
7017	1B69	FR1 Polling Total	FP	RO
7018	1B6A	FR1 Previous Day Total	FP	RO
7019	1B6B	FR1 Previous Interval	FP	RO
7020	1B6C	FR1 Previous Polling Total	FP	RO
7021	1B6D	FR1 Grand Mass Total	FP	RO
7022	1B6E	FR1 Instantaneous Mass Flow Rate	FP	RO
7023	1B6F	FR1 Daily Mass Total	FP	RO
7024	1B70	FR1 Interval Mass Total	FP	RO
7025	1B71	FR1 Polling Mass Total	FP	RO
7026	1B72	FR1 Previous Day Mass	FP	RO
7027	1B73	FR1 Previous Interval Mass	FP	RO
7028	1B74	FR1 Previous Polling Mass	FP	RO
7029	1B75	FR1 Grand Energy Total	FP	RO
7030	1B76	FR1 Instantaneous Energy Flow Rate	FP	RO
7031	1B77	FR1 Daily Energy Total	FP	RO
7032	1B78	FR1 Interval Energy Total	FP	RO
7033	1B79	FR1 Polling Energy Total	FP	RO
7034	1B7A	FR1 Previous Day Energy	FP	RO
7035	1B7B	FR1 Previous Interval Energy	FP	RO

Holding Registers (32-bit)

Register (Decimal)	Register (Hex)	Description	Data Type	Access
7036	1B7C	FR1 Previous Polling Energy	FP	RO
7037	1B7D	FR1 Daily Estimated Total	FP	RO
7038	1B7E	FR1 Monthly Total	FP	RO
7039	1B7F	FR1 Previous Month Total	FP	RO
7040	1B80	FR1 Daily Run Time	FP	RO
7041	1B81	FR1 Interval Run Time	FP	RO
7042	1B82	FR1 Polling Run Time	FP	RO
7043	1B83	FR1 Previous Daily Run Time	FP	RO
7044	1B84	FR1 Previous Interval Run Time	FP	RO
7045	1B85	FR1 Previous Polling Run Time	FP	RO
7046	1B86	FR1 Static Pressure	FP	RO
7047	1B87	FR1 Differential Pressure	FP	RO
7048	1B88	FR1 Process Temperature	FP	RO
7049	1B89	FR1 Uncorrected Volume	FP	RO
7050	1B8A	FR1 SqrtDP	FP	RO
7051	1B8B	FR1 Compressibility	FP	RO
7052	1B8C	FR1 Density	FP	RO
7053	1B8D	FR1 Base Compressibility	FP	RO
7054	1B8E	FR1 Base Density	FP	RO
7055	1B8F	FR1 Average Molecular Weight	FP	RO
7056	1B90	FR1 Molar Fraction Sum	FP	RO
7057	1B91	FR1 Mass Heating Value	FP	RO
7058	1B92	FR1 Heating Value Volume Basis	FP	RO
7059	1B93	FR1 Specific Gravity	FP	RO
7060	1B94	FR1 Viscosity	FP	RO
7061	1B95	FR1 Isentropic Exponent	FP	RO
7062	1B96	FR1 Reynolds Number	FP	RO
7063	1B97	FR1 Calculation Parameter 1	FP	RO
7064	1B98	FR1 Calculation Parameter 2	FP	RO
7065	1B99	FR1 Calculation Parameter 3	FP	RO
7066	1B9A	FR1 Calculation Parameter 4	FP	RO
7067	1B9B	FR1 Calculation Parameter 5	FP	RO
7068	1B9C	FR1 Calculation Parameter 6	FP	RO
7069	1B9D	FR1 Calculation Parameter 7	FP	RO
7070	1B9E	FR1 Calculation Parameter 8	FP	RO
7071	1B9F	FR1 Calculation Parameter 9	FP	RO
7072	1BA0	FR1 Calculation Parameter 10	FP	RO
7073	1BA1	FR1 Calculation Parameter 11	FP	RO
7074	1BA2	FR1 Calculation Parameter 12	FP	RO
7075	1BA3	FR1 Calculation Parameter 13	FP	RO
7076	1BA4	FR1 Calculation Parameter 14	FP	RO

Holding Registers (32-bit)

Register (Decimal)	Register (Hex)	Description	Data Type	Access
7077	1BA5	FR1 Calculation Parameter 15	FP	RO
7078	1BA6	FR1 Calculation Parameter 16	FP	RO
7079	1BA7	FR1 Grand Total [MCF]	FP	RO
7080	1BA8	FR1 Instantaneous Flow Rate [MCF]	FP	RO
7081	1BA9	FR1 Daily Total [MCF]	FP	RO
7082	1BAA	FR1 Interval Total [MCF]	FP	RO
7083	1BAB	FR1 Polling Total [MCF]	FP	RO
7084	1BAC	FR1 Previous Day [MCF]	FP	RO
7085	1BAD	FR1 Previous Interval [MCF]	FP	RO
7086	1BAE	FR1 Previous Polling Total [MCF]	FP	RO
7087	1BAF	FR1 Grand Mass Total [LBM]	FP	RO
7088	1BB0	FR1 Instantaneous Mass Rate [LBM]	FP	RO
7089	1BB1	FR1 Daily Mass Total [LBM]	FP	RO
7090	1BB2	FR1 Interval Mass Total [LBM]	FP	RO
7091	1BB3	FR1 Polling Mass Total [LBM]	FP	RO
7092	1BB4	FR1 Previous Day Mass [LBM]	FP	RO
7093	1BB5	FR1 Previous Interval Mass [LBM]	FP	RO
7094	1BB6	FR1 Previous Polling Mass [LBM]	FP	RO
7095	1BB7	FR1 Grand Energy Total [MMBTU]	FP	RO
7096	1BB8	FR1 Instantaneous Energy Rate [MMBTU]	FP	RO
7097	1BB9	FR1 Daily Energy Total [MMBTU]	FP	RO
7098	1BBA	FR1 Interval Energy Total [MMBTU]	FP	RO
7099	1BBB	FR1 Polling Energy Total [MMBTU]	FP	RO
7100	1BBC	FR1 Previous Day Energy [MMBTU]	FP	RO
7101	1BBD	FR1 Previous Interval Energy [MMBTU]	FP	RO
7102	1BBE	FR1 Previous Polling Energy [MMBTU]	FP	RO
7103	1BBF	FR1 Daily Estimated Total [MCF]	FP	RO
7104	1BC0	FR1 Monthly Total [MCF]	FP	RO
7105	1BC1	FR1 Previous Month Total [MCF]	FP	RO
7106	1BC2	FR1 Mass Heating Value [BASE]	FP	RO
7107	1BC3	FR1 Volumetric Heating Value [BASE]	FP	RO
7108	1BC4	T1 Grand Total	FP	RO
7109	1BC5	T1 Instantaneous Flow Rate	FP	RO
7110	1BC6	T1 Daily Total	FP	RO
7111	1BC7	T1 Interval Total	FP	RO
7112	1BC8	T1 Polling Total	FP	RO
7113	1BC9	T1 Previous Day	FP	RO
7114	1BCA	T1 Previous Interval	FP	RO
7115	1BCB	T1 Previous Polling Total	FP	RO
7116	1BCC	T1 Daily Estimated Total	FP	RO
7117	1BCD	T1 Monthly Total	FP	RO

Holding Registers (32-bit)

Register (Decimal)	Register (Hex)	Description	Data Type	Access
7118	1BCE	T1 Previous Month Total	FP	RO
7119	1BCF	T1 Daily Run Time	FP	RO
7120	1BD0	T1 Interval Run Time	FP	RO
7121	1BD1	T1 Polling Run Time	FP	RO
7122	1BD2	T1 Previous Daily Run Time	FP	RO
7123	1BD3	T1 Previous Interval Run Time	FP	RO
7124	1BD4	T1 Previous Polling Run Time	FP	RO
7125	1BD5	T1 Grand Total [GAL]	FP	RO
7126	1BD6	T1 Instantaneous Flow Rate [GAL]	FP	RO
7127	1BD7	T1 Daily Total [GAL]	FP	RO
7128	1BD8	T1 Interval Total [GAL]	FP	RO
7129	1BD9	T1 Polling Total [GAL]	FP	RO
7130	1BDA	T1 Previous Day [GAL]	FP	RO
7131	1BDB	T1 Previous Interval [GAL]	FP	RO
7132	1BDC	T1 Previous Polling Total [GAL]	FP	RO
7133	1BDD	T1 Daily Estimated Total [GAL]	FP	RO
7134	1BDE	T1 Monthly Total [GAL]	FP	RO
7135	1BDF	T1 Previous Month Total [GAL]	FP	RO
7136	1BE0	T1 Frequency	FP	RO
7137	1BE1	T1 Active K-Factor	FP	RO
7138	1BE2	T2 Grand Total	FP	RO
7139	1BE3	T2 Instantaneous Flow Rate	FP	RO
7140	1BE4	T2 Daily Total	FP	RO
7141	1BE5	T2 Interval Total	FP	RO
7142	1BE6	T2 Polling Total	FP	RO
7143	1BE7	T2 Previous Day	FP	RO
7144	1BE8	T2 Previous Interval	FP	RO
7145	1BE9	T2 Previous Polling Total	FP	RO
7146	1BEA	T2 Daily Estimated Total	FP	RO
7147	1BEB	T2 Monthly Total	FP	RO
7148	1BEC	T2 Previous Month Total	FP	RO
7149	1BED	T2 Daily Run Time	FP	RO
7150	1BEE	T2 Interval Run Time	FP	RO
7151	1BEF	T2 Polling Run Time	FP	RO
7152	1BF0	T2 Previous Daily Run Time	FP	RO
7153	1BF1	T2 Previous Interval Run Time	FP	RO
7154	1BF2	T2 Previous Polling Run Time	FP	RO
7155	1BF3	T2 Grand Total [GAL]	FP	RO
7156	1BF4	T2 Instantaneous Flow Rate [GAL]	FP	RO
7157	1BF5	T2 Daily Total [GAL]	FP	RO
7158	1BF6	T2 Interval Total [GAL]	FP	RO

Holding Registers (32-bit)

Register (Decimal)	Register (Hex)	Description	Data Type	Access
7159	1BF7	T2 Polling Total [GAL]	FP	RO
7160	1BF8	T2 Previous Day Total [GAL]	FP	RO
7161	1BF9	T2 Previous Interval [GAL]	FP	RO
7162	1BFA	T2 Previous Polling Total [GAL]	FP	RO
7163	1BFB	T2 Daily Estimated Total [GAL]	FP	RO
7164	1BFC	T2 Monthly Total [GAL]	FP	RO
7165	1BFD	T2 Previous Month Total [GAL]	FP	RO
7166	1BFE	T2 Frequency	FP	RO
7167	1BFF	T2 Active K-Factor	FP	RO
7168	1C00	SP Instantaneous Reading	FP	RO
7169	1C01	SP Rate Of Change	FP	RO
7170	1C02	SP Daily Average	FP	RO
7171	1C03	SP Interval Average	FP	RO
7172	1C04	SP Polling Average	FP	RO
7173	1C05	SP Previous Daily Average	FP	RO
7174	1C06	SP Previous Interval Average	FP	RO
7175	1C07	SP Previous Polling Average	FP	RO
7176	1C08	SP Daily Run Time	FP	RO
7177	1C09	SP Interval Run Time	FP	RO
7178	1C0A	SP Polling Run Time	FP	RO
7179	1C0B	SP Previous Daily Run Time	FP	RO
7180	1C0C	SP Previous Interval Run Time	FP	RO
7181	1C0D	SP Previous Polling Run Time	FP	RO
7182	1C0E	SP Instantaneous Reading [PSI]	FP	RO
7183	1C0F	SP Rate of Change [PSI]	FP	RO
7184	1C10	SP Daily Average [PSI]	FP	RO
7185	1C11	SP Interval Average [PSI]	FP	RO
7186	1C12	SP Polling Average [PSI]	FP	RO
7187	1C13	SP Previous Daily Average [PSI]	FP	RO
7188	1C14	SP Previous Interval Average [PSI]	FP	RO
7189	1C15	SP Previous Polling Average [PSI]	FP	RO
7190	1C16	DP Instantaneous Reading	FP	RO
7191	1C17	DP Rate Of Change	FP	RO
7192	1C18	DP Daily Average	FP	RO
7193	1C19	DP Interval Average	FP	RO
7194	1C1A	DP Polling Average	FP	RO
7195	1C1B	DP Previous Daily Average	FP	RO
7196	1C1C	DP Previous Interval Average	FP	RO
7197	1C1D	DP Previous Polling Average	FP	RO
7198	1C1E	DP Daily Run Time	FP	RO
7199	1C1F	DP Interval Run Time	FP	RO

Holding Registers (32-bit)

Register (Decimal)	Register (Hex)	Description	Data Type	Access
7200	1C20	DP Polling Run Time	FP	RO
7201	1C21	DP Previous Daily Run Time	FP	RO
7202	1C22	DP Previous Interval Run Time	FP	RO
7203	1C23	DP Previous Polling Run Time	FP	RO
7204	1C24	DP Instantaneous Reading [INH2O]	FP	RO
7205	1C25	DP Rate of Change [INH2O]	FP	RO
7206	1C26	DP Daily Average [INH2O]	FP	RO
7207	1C27	DP Interval Average [INH2O]	FP	RO
7208	1C28	DP Polling Average [INH2O]	FP	RO
7209	1C29	DP Previous Daily Average [INH2O]	FP	RO
7210	1C2A	DP Previous Interval Average [INH2O]	FP	RO
7211	1C2B	DP Previous Polling Average [INH2O]	FP	RO
7212	1C2C	PT Instantaneous Reading	FP	RO
7213	1C2D	PT Rate Of Change	FP	RO
7214	1C2E	PT Daily Average	FP	RO
7215	1C2F	PT Interval Average	FP	RO
7216	1C30	PT Polling Average	FP	RO
7217	1C31	PT Previous Daily Average	FP	RO
7218	1C32	PT Previous Interval Average	FP	RO
7219	1C33	PT Previous Polling Average	FP	RO
7220	1C34	PT Daily Run Time	FP	RO
7221	1C35	PT Interval Run Time	FP	RO
7222	1C36	PT Polling Run Time	FP	RO
7223	1C37	PT Previous Daily Run Time	FP	RO
7224	1C38	PT Previous Interval Run Time	FP	RO
7225	1C39	PT Previous Polling Run Time	FP	RO
7226	1C3A	PT Instantaneous Reading [DEGF]	FP	RO
7227	1C3B	PT Rate of Change [DEGF]	FP	RO
7228	1C3C	PT Daily Average [DEGF]	FP	RO
7229	1C3D	PT Interval Average [DEGF]	FP	RO
7230	1C3E	PT Polling Average [DEGF]	FP	RO
7231	1C3F	PT Previous Daily Average [DEGF]	FP	RO
7232	1C40	PT Previous Interval Average [DEGF]	FP	RO
7233	1C41	PT Previous Polling Average [DEGF]	FP	RO
7234	1C42	A1 Instantaneous Reading	FP	RO
7235	1C43	A1 Rate Of Change	FP	RO
7236	1C44	A1 Daily Average	FP	RO
7237	1C45	A1 Interval Average	FP	RO
7238	1C46	A1 Polling Average	FP	RO
7239	1C47	A1 Previous Daily Average	FP	RO

Holding Registers (32-bit)

Register (Decimal)	Register (Hex)	Description	Data Type	Access
7240	1C48	A1 Previous Interval Average	FP	RO
7241	1C49	A1 Previous Polling Average	FP	RO
7242	1C4A	A1 Daily Run Time	FP	RO
7243	1C4B	A1 Interval Run Time	FP	RO
7244	1C4C	A1 Polling Run Time	FP	RO
7245	1C4D	A1 Previous Daily Run Time	FP	RO
7246	1C4E	A1 Previous Interval Run Time	FP	RO
7247	1C4F	A1 Previous Polling Run Time	FP	RO
7248	1C50	A1 Instantaneous Reading [VOLT]	FP	RO
7249	1C51	A1 Rate of Change [VOLT]	FP	RO
7250	1C52	A1 Daily Average [VOLT]	FP	RO
7251	1C53	A1 Interval Average [VOLT]	FP	RO
7252	1C54	A1 Polling Average [VOLT]	FP	RO
7253	1C55	A1 Previous Daily Average [VOLT]	FP	RO
7254	1C56	A1 Previous Interval Average [VOLT]	FP	RO
7255	1C57	A1 Previous Polling Average [VOLT]	FP	RO
7256	1C58	A2 Instantaneous Reading	FP	RO
7257	1C59	A2 Rate Of Change	FP	RO
7258	1C5A	A2 Daily Average	FP	RO
7259	1C5B	A2 Interval Average	FP	RO
7260	1C5C	A2 Polling Average	FP	RO
7261	1C5D	A2 Previous Daily Average	FP	RO
7262	1C5E	A2 Previous Interval Average	FP	RO
7263	1C5F	A2 Previous Polling Average	FP	RO
7264	1C60	A2 Daily Run Time	FP	RO
7265	1C61	A2 Interval Run Time	FP	RO
7266	1C62	A2 Polling Run Time	FP	RO
7267	1C63	A2 Previous Daily Run Time	FP	RO
7268	1C64	A2 Previous Interval Run Time	FP	RO
7269	1C65	A2 Previous Polling Run Time	FP	RO
7270	1C66	A2 Instantaneous Reading [VOLT]	FP	RO
7271	1C67	A2 Rate of Change [VOLT]	FP	RO
7272	1C68	A2 Daily Average [VOLT]	FP	RO
7273	1C69	A2 Interval Average [VOLT]	FP	RO
7274	1C6A	A2 Polling Average [VOLT]	FP	RO
7275	1C6B	A2 Previous Daily Average [VOLT]	FP	RO
7276	1C6C	A2 Previous Interval Average [VOLT]	FP	RO
7277	1C6D	A2 Previous Polling Average [VOLT]	FP	RO
7278	1C6E	Internal Temperature	FP	RO
7279	1C6F	Supply Voltage	FP	RO
7280	1C70	Battery Voltage	FP	RO

Holding Registers (32-bit)

Register (Decimal)	Register (Hex)	Description	Data Type	Access
7281	1C71	Live FR1 Instantaneous Flow Rate [BASE]	FP	RO
7282		Reserved		
7283	1C73	Live T1 Instantaneous Flow Rate [GAL]	FP	RO
7284	1C74	Live T2 Instantaneous Flow Rate [GAL]	FP	RO
7285	1C75	Live Turbine Frequency Differential	FP	RO
7286	1C76	Live Turbine Frequency Ratio	FP	RO
7287	1C77	Live Static Pressure	FP	RO
7288	1C78	Live Differential Pressure	FP	RO
7289	1C79	Live MVT Temperature	FP	RO
7290	1C7A	Live Bridge Voltage	FP	RO
7291	1C7B	Live Analog 1	FP	RO
7292	1C7C	Live Analog 2	FP	RO
7293	1C7D	Live Production Temperature	FP	RO
7294	1C7E	Live RTD Resistance	FP	RO
7295	1C7F	PID Stage 1 Status	FP	RO
7296	1C80	PID Stage 1 Output	FP	RO
7297	1C81	PID Stage 2 Status	FP	RO
7298	1C82	PID Stage 2 Output	FP	RO
7299	1C83	PO1 Pulses	FP	RO
7300-7302		Reserved		
7303	1C87	AO1 Output Current	FP	RO
7304	1C88	AO2 Output Current	FP	RO
7305	1C89	AO3 Output Current	FP	RO
7306	1C8A	AO4 Output Current	FP	RO
7307	1C8B	AO1 DAC Output	FP	RO
7308	1C8C	AO2 DAC Output	FP	RO
7309	1C8D	AO3 DAC Output	FP	RO
7310	1C8E	AO4 DAC Output	FP	RO
7311-7312		Reserved		
7313	1C91	PI2 State	FP	RO
7314	1C92	PI2 Count	FP	RO
7315-7318		Reserved		
7319	1C97	Daily Archive Date	FP	RO
7320	1C98	Interval Archive Date	FP	RO
7321	1C99	Daily Archive Time	FP	RO
7322	1C9A	Interval Archive Time	FP	RO
7323	1C9B	Slave Data Point 01	FP	RO
7324	1C9C	Slave Data Point 02	FP	RO
7325	1C9D	Slave Data Point 03	FP	RO
7326	1C9E	Slave Data Point 04	FP	RO
7327	1C9F	Slave Data Point 05	FP	RO

Holding Registers (32-bit)

Register (Decimal)	Register (Hex)	Description	Data Type	Access
7328	1CA0	Slave Data Point 06	FP	RO
7329	1CA1	Slave Data Point 07	FP	RO
7330	1CA2	Slave Data Point 08	FP	RO
7331	1CA3	Slave Data Point 09	FP	RO
7332	1CA4	Slave Data Point 10	FP	RO
7333	1CA5	Slave Data Point 11	FP	RO
7334	1CA6	Slave Data Point 12	FP	RO
7335	1CA7	Slave Data Point 13	FP	RO
7336	1CA8	Slave Data Point 14	FP	RO
7337	1CA9	Slave Data Point 15	FP	RO
7338	1CAA	Slave Data Point 16	FP	RO

User-Defined Modbus Registers Configuration

The Scanner 2000 provides a block of 25 floating point values that the user can assign to any register in the holding register map. This optimizes communication by allowing the parameters that are of interest for a given application to be organized and read in a single block read. For details on configuring User-Defined Holding Registers, see Section 3 of the ModWorX Pro Software User Manual. Each of the user-defined holding registers is determined by a pointer value in the holding register map. It is easiest to configure the pointer values with the ModWorX Pro software; however the pointer value can be determined with the following calculation: $(\text{Holding Register Number} - 8000) / 2$.

User-Defined Register Pointers

Register (Decimal)	Register (Hex)	Description	Data Type	Access
9000	2328	User-Defined Starting Address (Always 9100)	U16	RO
9001	2329	Register Pointer 1	U16	R/W
9002	232A	Register Pointer 2	U16	R/W
9003	232B	Register Pointer 3	U16	R/W
9004	232C	Register Pointer 4	U16	R/W
9005	232D	Register Pointer 5	U16	R/W
9006	232E	Register Pointer 6	U16	R/W
9007	232F	Register Pointer 7	U16	R/W
9008	2330	Register Pointer 8	U16	R/W
9009	2331	Register Pointer 9	U16	R/W
9010	2332	Register Pointer 10	U16	R/W
9011	2333	Register Pointer 11	U16	R/W
9012	2334	Register Pointer 12	U16	R/W
9013	2335	Register Pointer 13	U16	R/W

User-Defined Register Pointers

Register (Decimal)	Register (Hex)	Description	Data Type	Access
9014	2336	Register Pointer 14	U16	R/W
9015	2337	Register Pointer 15	U16	R/W
9016	2338	Register Pointer 16	U16	R/W
9017	2339	Register Pointer 17	U16	R/W
9018	233A	Register Pointer 18	U16	R/W
9019	233B	Register Pointer 19	U16	R/W
9020	233C	Register Pointer 20	U16	R/W
9021	233D	Register Pointer 21	U16	R/W
9022	233E	Register Pointer 22	U16	R/W
9023	233F	Register Pointer 23	U16	R/W
9024	2340	Register Pointer 24	U16	R/W
9025	2341	Register Pointer 25	U16	R/W

User-Defined Holding Registers

Register (Decimal)	Register (Hex)	Description	Data Type	Access
9100	238C	User-Defined Holding Register 1	FP	RO
9102	238E	User-Defined Holding Register 2	FP	RO
9104	2390	User-Defined Holding Register 3	FP	RO
9106	2392	User-Defined Holding Register 4	FP	RO
9108	2394	User-Defined Holding Register 5	FP	RO
9110	2396	User-Defined Holding Register 6	FP	RO
9112	2398	User-Defined Holding Register 7	FP	RO
9114	239A	User-Defined Holding Register 8	FP	RO
9116	239C	User-Defined Holding Register 9	FP	RO
9118	239E	User-Defined Holding Register 10	FP	RO
9120	23A0	User-Defined Holding Register 11	FP	RO
9122	23A2	User-Defined Holding Register 12	FP	RO
9124	23A4	User-Defined Holding Register 13	FP	RO
9126	23A6	User-Defined Holding Register 14	FP	RO
9128	23A8	User-Defined Holding Register 15	FP	RO
9130	23AA	User-Defined Holding Register 16	FP	RO
9132	23AC	User-Defined Holding Register 17	FP	RO
9134	23AE	User-Defined Holding Register 18	FP	RO
9136	23B0	User-Defined Holding Register 19	FP	RO
9138	23B2	User-Defined Holding Register 20	FP	RO
9140	23B4	User-Defined Holding Register 21	FP	RO
9142	23B6	User-Defined Holding Register 22	FP	RO
9144	23B8	User-Defined Holding Register 23	FP	RO
9146	23BA	User-Defined Holding Register 24	FP	RO

User-Defined Holding Registers

Register (Decimal)	Register (Hex)	Description	Data Type	Access
9148	23BC	User-Defined Holding Register 25	FP	RO

Device Status

The device status includes alarm status and diagnostic information such as input status and calculation status. The Scanner 2000 provides 16 user-configurable alarms designated as Flow Run Alarms. The user can assign the alarms to any parameter in the holding register map. Alarms can be defined as low alarms or high alarms. For details on configuring Flow Run Alarms, see Section 3 of the ModWorX Pro Software User Manual. The current status of the alarms can be obtained by reading the Flow Run Alarm registers in the device status map. A bit value of 1 indicates an alarm condition. Also contained in the device status map are diagnostic registers. The bits in these registers provide system status for inputs (under range, above range or failed), calculation status (for confirming whether the flow run is working properly) and details regarding the health of the MVT.

Device Status Registers

Register (Decimal)	Register (Hex)	Description	Data Type	Access
9900	26AC	Flow Run Alarms High	U32	R/W
9902	26AE	Input Status	U32	R/W
9904	26B0	Calculation Status	U32	R/W

Bit Definitions—Alarms and Diagnostics

Bit	Flow Run Alarm High	Flow Run Alarm Low	Diagnostic 1	Diagnostic 2	Diagnostic 3	Diagnostic 4
15	FRA16 High	FRA16 Low	FR1 Fail	FR1 High	Reserved	Reserved
14	FRA15 High	FRA15 Low	T1 Fail	T1 High	Reserved	Reserved
13	FRA14 High	FRA14 Low	T2 Fail	T2 High	T2 Calc Warning	Reserved
12	FRA13 High	FRA13 Low	SP Fail	SP High	T1 Calc Warning	Reserved
11	FRA12 High	FRA12 Low	DP Fail	DP High	Reserved	Reserved
10	FRA11 High	FRA11 Low	PT Fail	PT High	Reserved	Reserved
9	FRA10 High	FRA10 Low	A1 Fail	A1 High	Reserved	Reserved
8	FRA9 High	FRA9 Low	A2 Fail	A2 High	FR1 Calc Warning	Reserved
7	FRA8 High	FRA8 Low	FR1 Override	FR1 Low	NA	Reserved
6	FRA7 High	FRA7 Low	T1 Override	T1 Low	NA	Reserved

Bit Definitions—Alarms and Diagnostics

Bit	Flow Run Alarm High	Flow Run Alarm Low	Diagnostic 1	Diagnostic 2	Diagnostic 3	Diagnostic 4
5	FRA6 High	FRA6 Low	T2 Override	SP Low	MVT M3 Formula Fail	Reserved
4	FRA5 High	FRA5 Low	SP Override	Reserved	MVT M2 Formula Fail	Power Mode
3	FRA4 High	FRA4 Low	DP Override	DP Low	MVT M1 Formula Fail	Reserved
2	FRA3 High	FRA3 Low	PT Override	PT Low	MVT User Parameter CRC fail	Reserved
1	FRA2 High	FRA2 Low	A1 Override	A1 Low	MVT Factory Parameter CRC fail	Device Seal
0	FRA1 High	FRA1 Low	A2 Override	A2 Low	MVT Not Present	Ext. Switch

The Scanner 2000 produces low, high and fail conditions for the inputs (not the flow alarms) in accordance with the following table.

Status	Range Check
Low	Lower Range Limit - 20% of span
Fail Low	Lower Range Limit - 500% of span
High	Upper Range Limit + 20% of span
Fail High	Upper Range Limit + 500% of span

Units of Measurement

Value	Units	Scale	Offset
101	GAL - BASE	1.000000000000	0.00
102	BBL	0.023809523810	0.00
103	M3	0.003785411780	0.00
104	LIT	3.785411784000	0.00
105	CF	0.133680555560	0.00
106	ACF	0.133680555560	0.00
107	ACM	0.003785411780	0.00
201	MCF - BASE	1.000000000	0.00
202	SCF	1000.000000000	0.00
203	M3	28.316846592	0.00
204	GAL	7480.519480271	0.00
205	BBL	178.107606673	0.00
207	LIT	28316.846592000	0.00
301	PSIG - BASE	1.00000000	0.00
302	Pa	6894.75729317	0.00
303	Kpa	6.89475729317	0.00
304	Mpa	0.00689475729317	0.00

Units of Measurement

Value	Units	Scale	Offset
305	Bar	0.06894757	0.00
306	In H2O	27.70500000	0.00
401	In H2O - BASE	1.000000000000	0.00
402	Pa	248.641080600000	0.00
403	Kpa	0.248641080600	0.00
404	mmHg	1.865077000000	0.00
405	In Hg	0.07342822834646	0.00
406	PSI	0.036094567768	0.00
407	kgf/cm2	0.002535630000	0.00
408	mBar	2.48641011188	0.00
501	Deg F - BASE	1.00	0.00
502	Deg C	0.555555556	-17.77777778
503	K	0.555555556	255.3722222
504	Deg R	1.00	459.67
601	LBM - BASE	1.0000000000	0.00
602	kg	0.45359237000	0.00
701	MMBTU - BASE	1.0000000000	0.00
702	GJ	1.05505585262	0.00
703	BTU	1000000.0000000000	0.00
704	KJ	1055055.8526200000	0.00
801	GAL - BASE	1.000000000000	0.00
802	BBL	42.000000000000	0.00
803	M3	264.172052637296	0.00
804	LIT	0.264172052358	0.00
805	CF	7.480519480271	0.00
806	ACF	7.480519480271	0.00
807	ACM	264.172052637296	0.00
901	Volts	1.0000000000	0.00
902	Millivolts	1000.000000000000	0.00
1001	LBM/CU FT	1.0000000000	0.00
1002	KG/M3	16.01846433740	0.00
1201	inches	1.0000000000	0.00
1202	ft	0.08333333333	0.00
1203	yard	0.02777777778	0.00
1204	mile	0.0000157828	0.00
1205	mm	25.400000000000	0.00
1206	cm	2.5400000000	0.00
1208	m	0.0254000000	0.00
1209	km	0.00002540000	0.00
1301	Hz	1.0000000000	0.00
1302	kHz	0.0010000000	0.00

Units of Measurement

Value	Units	Scale	Offset
1303	MHz	0.0000010000	0.00
1401	ohms	1.0000000000	0.00
1402	kiloohms	0.0010000000	0.00
1403	megaohms	0.0000010000	0.00
1501	mA	1.0000000000	0.00
1502	A	0.0010000000	0.00
1601	cP	1.0000000000	0.00
1602	lbm/ft.sec	1488.1159420290	0.00

Log Capacity

Log Type	Capacity
Interval Logs (without expansion board)	2304
Interval Logs (with expansion board)	6392
Daily Logs	768
Event Logs	1152

Enron Log Data

The Scanner 2000 provides Enron Modbus® compliant downloads. For detailed instructions on downloading interval, daily and event data, refer to *Specifications and Requirements for an Electronic Flow Measurement Remote Terminal Unit for Enron Corp.* If an Enron host is not available or is too cumbersome or inefficient for the host system, there are other methods that are available to retrieve the log data from the instrument. Contact Cameron technical support for details.

The following registers are used for interval, daily and event log registers. Interval and daily records contain 16 user-configurable values. For details on the archive configuration, see Section 3 of the ModWorX Pro Software User Manual. All of the Enron registers have an access type of Read Only (RO).

Enron Registers

Register	Description	Data Type
32	Enron Modbus® Event Log Register	Refer to Enron Event Record Format
700	Enron Modbus® Interval Log	Refer to Enron Interval/Daily Record Format
701	Enron Modbus® Daily Log	Refer to Enron Interval/Daily Record Format
7000	Interval Pointer [1 to 2304, standard Scanner 2000] [1 to 6392, Scanner 2000 plus expansion board]	FP32
7001	Daily Pointer [1 to 768]	FP32
7002	Event Counter [1 to 2304]	FP32

Enron Interval/Daily Record Format

The interval and daily record contents are user-configurable. The following table shows the default values. For more information, see Section 3 of the ModWorX Pro Software User Manual.

Parameter	Data Type
Date (MMDDYY)	FP32
Time (HH:MM:SS)	FP32
FR1 Previous Volume (base units)	FP32
FR1 Previous Mass (base units)	FP32
FR1 Previous Energy (base units)	FP32
Differential Pressure Previous Average (InH ₂ O)	FP32
Static Pressure Previous Average (PSIA default, can be PSIG)	FP32
Process Temperature Previous Average (DegF)	FP32
FR1 Previous Run Time (seconds of flow)	FP32
Turbine 1 Previous Volume (base units)	FP32
Turbine 1 Previous Run Time (seconds of flow)	FP32
<Parameter 12>	FP32
<Parameter 13>	FP32
<Parameter 14>	FP32
<Parameter 15>	FP32
<Parameter 16>	FP32

Enron Event Record Format

Parameter	Data Type
Status	U16
Address	U16
Time (HH:MM:SS)	FP32
Date (MMDDYY)	FP32
As-Found	FP32
As-Left	FP32

The status parameter in the event record can be decoded with the following table.

Alarm Decoding

Description	Bit
<Unassigned>	0-8
User Change/Event	9
Low Low Alarm	10
Low Alarm	11
Hi Alarm	12
Hi Hi Alarm	13
<Unassigned>	14
Alarm Set/Reset (1=Set, 0=Reset)	15

Log Capacity

Log Type	Capacity
Interval Logs (without expansion board)	2304
Interval Logs (with expansion board)	6392
Daily Logs	768
Event Logs	1152

WARRANTY - LIMITATION OF LIABILITY: Seller warrants only title to the products, software, supplies and materials and that, except as to software, the same are free from defects in workmanship and materials for a period of one (1) year from the date of delivery. Seller does not warrant that software is free from error or that software will run in an uninterrupted fashion. Seller provides all software "as is". THERE ARE NO WARRANTIES, EXPRESS OR IMPLIED, OF MERCHANTABILITY, FITNESS OR OTHERWISE WHICH EXTEND BEYOND THOSE STATED IN THE IMMEDIATELY PRECEDING SENTENCE. Seller's liability and Buyer's exclusive remedy in any case of action (whether in contract, tort, breach of warranty or otherwise) arising out of the sale or use of any products, software, supplies, or materials is expressly limited to the replacement of such products, software, supplies, or materials on their return to Seller or, at Seller's option, to the allowance to the customer of credit for the cost of such items. In no event shall Seller be liable for special, incidental, indirect, punitive or consequential damages. Seller does not warrant in any way products, software, supplies and materials not manufactured by Seller, and such will be sold only with the warranties that are given by the manufacturer thereof. Seller will pass only through to its purchaser of such items the warranty granted to it by the manufacturer.
