

M10S Ball Valve DN $\frac{1}{4}$ " to DN $2\frac{1}{2}$ "

Screwed, SW, BW and Flanged versions

Installation and Maintenance Instructions

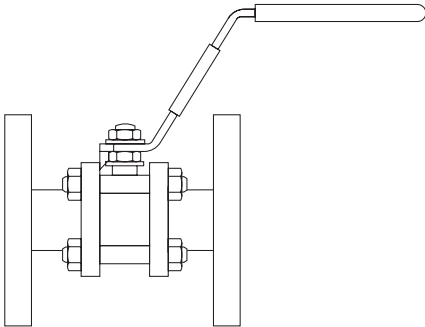

1. Safety information
2. General product information
3. Installation
4. Commissioning
5. Operation
6. Maintenance
7. Spare parts

1. Safety information

Safe operation of this product can only be guaranteed if it is properly installed, commissioned, used and maintained by qualified personnel (see Section 1.11) in compliance with the operating instructions. General installation and safety instructions for pipeline and plant construction, as well as the proper use of tools and safety equipment must also be complied with.

1.1 Intended use

Referring to the Installation and Maintenance Instructions, name-plate and Technical Information Sheet, check that the product is suitable for the intended use/application.

The product listed below complies with the requirements of the Pressure Equipment Directive (PED) and carries the  mark when so required.

The product falls within the following Pressure Equipment Directive categories:

Product	Group 1 Gases	Group 2 Gases	Group 1 Liquids	Group 2 Liquids
M10S PDR 0.8 seats (Carbon/graphite reinforced PTFE)	DN¼"	SEP	SEP	SEP
	DN⅜"	SEP	SEP	SEP
	DN½"	SEP	SEP	SEP
	DN¾"	SEP	SEP	SEP
	DN1"	SEP	SEP	SEP
	DN1¼"	2	SEP	2
	DN1½"	2	1	2
	DN2"	2	1	2
	DN2½"	2	1	2

- i) The product has been specifically designed for use on steam, compressed air, water/ condensate and other industrial fluids that are in Group 2 of the above mentioned Pressure Equipment Directive.
- ii) Determine the correct installation situation and direction of fluid flow.
- iii) Spirax Sarco products are not intended to withstand external stresses that may be induced by any system to which they are fitted. It is the responsibility of the installer to consider these stresses and take adequate precautions to minimise them.
- iv) Remove protection covers from all connections and protective film from all name-plates, where appropriate, before installation on steam or other high temperature applications.

1.2 Access

Ensure safe access and if necessary a safe working platform (suitably guarded) before attempting to work on the product. Arrange suitable lifting gear if required.

1.3 Lighting

Ensure adequate lighting, particularly where detailed or intricate work is required.

1.4 Hazardous liquids or gases in the pipeline

Consider what is in the pipeline or what may have been in the pipeline at some previous time. Consider: flammable materials, substances hazardous to health, extremes of temperature.

1.5 Hazardous environment around the product

Consider: explosion risk areas, lack of oxygen (e.g. tanks, pits), dangerous gases, extremes of temperature, hot surfaces, fire hazard (e.g. during welding), excessive noise, moving machinery.

1.6 The system

Consider the effect on the complete system of the work proposed. Will any proposed action (e.g. closing isolation valves, electrical isolation) put any other part of the system or any personnel at risk?

Dangers might include isolation of vents or protective devices or the rendering ineffective of controls or alarms. Ensure isolation valves are turned on and off in a gradual way to avoid system shocks.

1.7 Pressure systems

Ensure that any pressure is isolated and safely vented to atmospheric pressure. Consider double isolation (double block and bleed) and the locking or labelling of closed valves. Do not assume that the system has depressurised even when the pressure gauge indicates zero.

1.8 Temperature

Allow time for temperature to normalise after isolation to avoid danger of burns.

If parts made from PTFE have been subjected to a temperature approaching 260 °C (500 °F) or higher, they will give off toxic fumes, which if inhaled are likely to cause temporary discomfort. It is essential for a no smoking rule to be enforced in all areas where PTFE is stored, handled or processed as persons inhaling the fumes from burning tobacco contaminated with PTFE particles can develop 'polymer fume fever'.

1.9 Tools and consumables

Before starting work ensure that you have suitable tools and/or consumables available. Use only genuine Spirax Sarco replacement parts.

1.10 Protective clothing

Consider whether you and/or others in the vicinity require any protective clothing to protect against the hazards of, for example, chemicals, high/low temperature, radiation, noise, falling objects, and dangers to eyes and face.

1.11 Permits to work

All work must be carried out or be supervised by a suitably competent person.

Installation and operating personnel should be trained in the correct use of the product according to the Installation and Maintenance Instructions.

Where a formal 'permit to work' system is in force it must be complied with. Where there is no such system, it is recommended that a responsible person should know what work is going on and, where necessary, arrange to have an assistant whose primary responsibility is safety. Post 'warning notices' if necessary.

1.12 Handling

Manual handling of large and/or heavy products may present a risk of injury. Lifting, pushing, pulling, carrying or supporting a load by bodily force can cause injury particularly to the back. You are advised to assess the risks taking into account the task, the individual, the load and the working environment and use the appropriate handling method depending on the circumstances of the work being done.

1.13 Residual hazards

In normal use the external surface of the product may be very hot. If used at the maximum permitted operating conditions the surface temperature of this product may reach temperatures of 260 °C (500 °F).

This product is not self-draining. Take due care when dismantling or removing the product from an installation (refer to 'Maintenance instructions').

1.14 Freezing

Provision must be made to protect products which are not self-draining against frost damage in environments where they may be exposed to temperatures below freezing point.

1.15 Safety information - Product specific

Hydraulic locking

Ball valves are prone to lock-up when used on certain heating/cooling applications where both steam and liquid will pass through the valve. This is caused by liquid trapped in the ball during closure being heated to create a high hydraulic pressure inside the ball cavity. To prevent this, during manufacture, a minute hole is drilled in the ball, so, that in the closed position, any excess pressure will be relieved. Spirax Sarco ball valves for these applications are clearly marked to allow the valve to be correctly installed, such that, when closed, the hole is facing the steam source.

Seat

If the 'O' rings have been subjected to a temperature approaching 260 °C (500 °F) or higher, they may have decomposed and formed hydrofluoric acid. Avoid skin contact and inhalation of any fumes as the acid can cause skin burns and damage to the respiratory system.

1.16 Disposal

Unless otherwise stated in the Installation and Maintenance Instructions, this product is recyclable and no ecological hazard is anticipated with its disposal providing due care is taken, with the exception of PTFE.

PTFE:

- Can only be disposed of by approved methods, not incineration.
- Keep PTFE waste in a separate container, do not mix it with other rubbish, and consign it to a landfill site.

1.17 Returning products

Customers and stockists are reminded that under EC Health, Safety and Environment Law, when returning products to Spirax Sarco they must provide information on any hazards and the precautions to be taken due to contamination residues or mechanical damage which may present a health, safety or environmental risk. This information must be provided in writing including Health and Safety data sheets relating to any substances identified as hazardous or potentially hazardous.

2. General product information

2.1 General description

The M10S three-piece body ball valve has been designed for use as an isolating valve, not a control valve, and can be serviced without removal from the pipeline (screwed and welded versions only). It can be used with the majority of industrial fluids for services ranging from vacuum to the higher temperatures and pressures.

Available types

M10S2 Zinc plated carbon steel body, PDR 0.8 seats

M10S3 Stainless steel body, PDR 0.8 seats

M10S4 Complete stainless steel, PDR 0.8 seats

Note: The nomenclature will be followed with either **FB** (full bore) or **RB** (reduced bore).

Standards

This product fully complies with the requirements of the Pressure Equipment Directive (PED) and carries the **CE** mark when so required.

Certification

This product is available with certification to EN 10204 3.1.

Note: All certification/inspection requirements must be stated at the time of order placement.

Note: For further information on this product see Technical Information sheet TI-P167-03-EN-ISS1.

2.2 Sizes and pipe connections

Full bore

¼", ⅜", ½", ¾", 1", 1¼", 1½" and 2"

Screwed and welded

BSP, BSPT, API/NPT, BW, SW

Flanged

DN15 to DN50

ASME (ANSI) Class 150, ASME (ANSI) Class 300 and EN 1092 PN40

Reduced bore

¼", ⅜", ½", ¾", 1", 1¼", 1½", 2" and 2½"

Screwed and welded

BSP, BSPT, API/NPT, BW, SW

Flanged

DN15 to DN65

ASME (ANSI) Class 150, ASME (ANSI) Class 300 and EN 1092 PN40

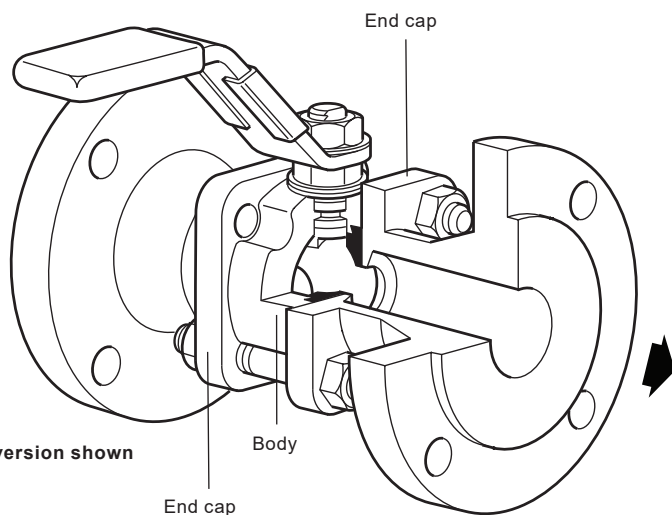
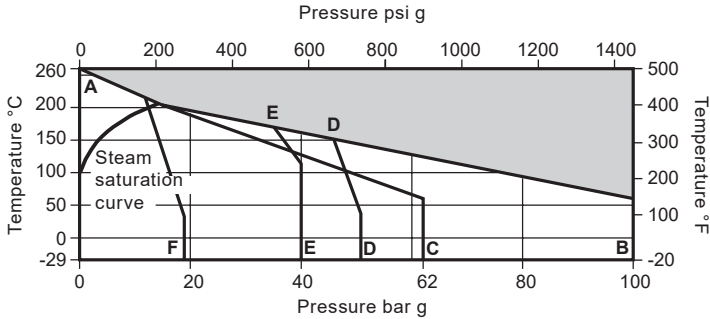

Fig. 1 M10S flanged version shown

2.3 Pressure/temperature limits



The product **must not** be used in this region.

- A - B Screwed, BW and SW ¼" - 1½" FB, RB and 2" RB.
- A - C Screwed, BW and SW 2" FB and 2½" RB only.
- A - D Flanged ASME (ANSI) 300.
- A - E Flanged EN 1092 PN40.
- A - E Flanged ASME (ANSI) 150.

Note 1: On the 2" FB and 2½" RB a PTFE gasket is fitted between the body and cap.

Note 2: The flange standard may restrict the maximum operating pressure. Please check with Spirax Sarco.

Body design conditions		ANSI 600	
PMA	Maximum allowable pressure	100 bar g @ 60 °C	(1 450 psi g @ 140 °F)
TMA	Maximum allowable temperature	260 °C @ 0 bar g	(500 °F @ 0 psi g)
	Minimum allowable temperature	-29 °C	(-20 °F)
PMO	Maximum operating pressure for saturated steam service	17.5 bar g	(254 psi g)
TMO	Maximum operating temperature	260 °C @ 0 bar g	(500 °F @ 0 psi g)
	Minimum operating temperature	-29 °C	(-20 °F)
Note: For lower operating temperatures consult Spirax Sarco			
ΔPMX	Maximum differential pressure is limited to the PMO		
Designed for a maximum cold hydraulic test pressure of:		150 bar g	(2175 psi g)

3. Installation

Note: Before actioning any installation observe the 'Safety information' in Section 1.

Although the valve has great structural integrity, severe misalignment and/or the pulling effect of incorrect pipe length will have a detrimental effect on the valve and must be avoided. Particular attention should be paid to correct pipe alignment such that the inlet pipework and valve are all on the same axis.

Valves are for on/off applications and may be operated manually.

Wherever practicable, valves should be installed where there is adequate space available so that they can be conveniently operated and maintained.

Before installing a valve, check to ensure that size, pressure rating, materials of construction, end connections, etc. are suitable for the service conditions of the particular application.

Care must be taken to ensure that all dirt which may have accumulated in the valve during storage is removed before installation, maintain cleanliness during installation since the introduction of dirt can result in damage to the valve seats and operating mechanism.

To minimise the danger of abrasive particles damaging the seats, pipeline strainers should be fitted upstream of the valves.

Install the valve with the handle in a suitable position. The preferred position is with the spindle vertical. The valve can be installed in any position for gas service (see Figure 3 below).

When used on steam services:

1. Fit a trapped drain pocket upstream of the valve.
2. Open valve slowly to prevent the risk of waterhammer damage.

Do not mount the valve upside down for liquid service (Figure 2).

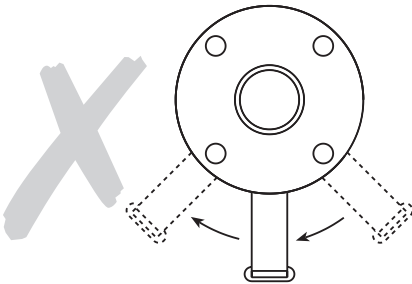

Fig. 2 Incorrect installation for liquid service

Valves should be installed into the pipeline in the fully closed position. **Prior to welding socket and butt weld valves into the pipeline, it will be necessary to:**

1. Dismantle the end caps from the body.
2. Remove the seats and body gasket.
3. Weld each end cap to the pipeline.
4. Replace the seats and body gasket.
5. Reassemble.

Always open valves slowly to avoid system shocks.

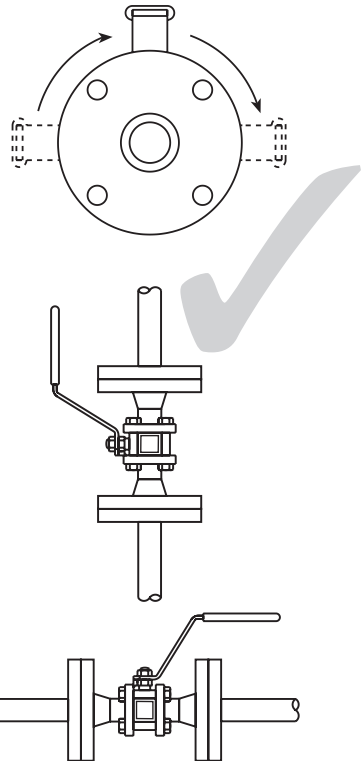

Fig. 3 Correct installation for gas service

4. Commissioning

After installation or maintenance ensure that the system is fully functioning. Carry out tests on any alarms or protective devices.

5. Operation

The valve is operated manually by a handle, or automatically by an actuator. Special care must be taken to ensure that the movement is made in the correct direction.

The valve can be used as an on/off control valve, and can be operated fully open or fully closed.

6. Maintenance

Note: Before actioning any maintenance programme observe the 'Safety information' in Section 1.

6.1 General information

As with all mechanical devices, regular maintenance is the most efficient means of ensuring continued operational efficiency.

Regular scheduled inspection of all valves is essential especially on valves which are operated only occasionally.

6.2 General maintenance

Maintenance work can be carried out without removing the complete ball valve from the pipeline. Remove the two upper bolts and nuts (15 and 16) and then loosen the two lower bolts. The complete body assembly can then be removed and any new parts fitted.

Flanged valve maintenance only - Remove the complete flanged valve from the pipeline. Remove the eight nuts (16) and withdraw the four studs (15). The complete body assembly can then be removed and new parts fitted.

6.3 To replace seats (5):

- Remove the body as described in Section 6.2.
- With the body removed, remove the seats (5).
- Fit new seats (5) pushing them into the body chamber.

6.4 To replace stem seals (6):

- Remove the body as described in Section 6.2.
- Remove the nuts (9 and 11) and the spring washers (8).
- Replace the stem seals (6).

6.5 Reassembly

Reassemble in reverse order to instructions given above. The studs and nuts (15 and 16) should be tightened to the recommended torques shown in Table 1 opposite.

After 24 hours in service, retighten the body studs and nuts.

Table 1 Recommended tightening torques

Item no.	Part	Size	N m	(lbf ft)
15 16	Studs Nuts	¼", ⅜", ½" RB	15	11
		½" FB ¾" RB	15	11
		¾" FB 1" RB	25	19.0
		1" FB 1¼" RB	25	19.0
		1¼" FB 1½" RB	40	30.0
		1½" FB 2" RB	57	42.0
		2" FB 2½" RB	75	55.0
9 and 11	Stem nuts	¼", ⅜", ½" RB	5.4 - 8.1	4 - 6
		½" FB ¾" RB	5.4 - 8.1	4 - 6
		¾" FB 1" RB	10.8 - 13.5	8 - 10
		1" FB 1¼" RB	17.5 - 20.3	13 - 15
		1¼" FB 1½" RB	17.5 - 20.3	13 - 15
		1½" FB 2" RB	34 - 40	25 - 30
		2" FB 2½" RB	40 - 47	30 - 35

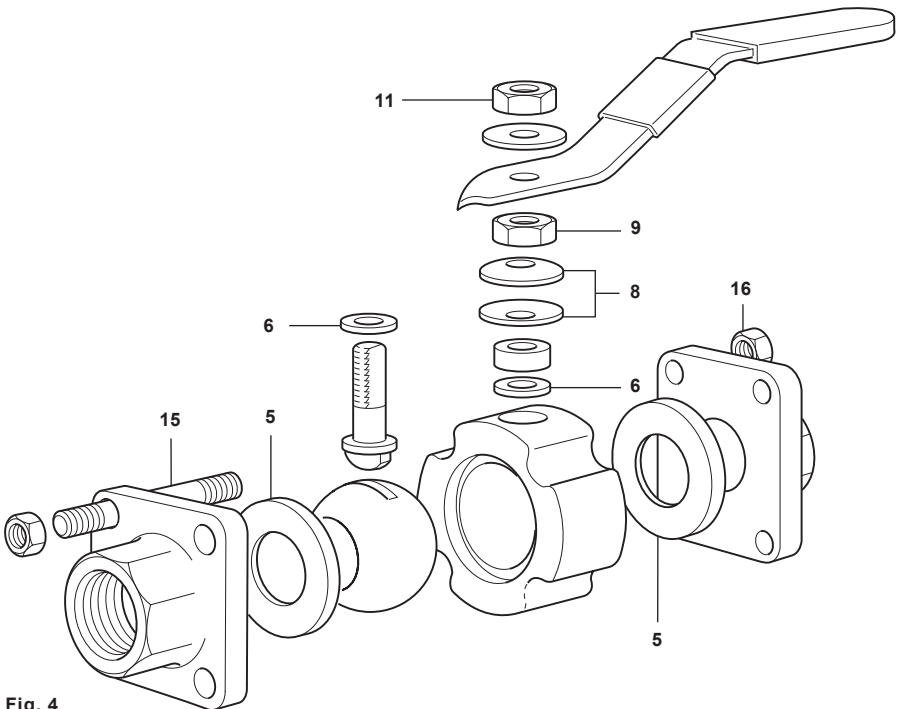

Fig. 4

7. Spare parts

The spare parts available are shown in solid outline. Parts drawn in a grey line are not supplied as spares.

Available spare

Seat and stem seal set

5, 6

How to order spares

Always order spares by using the description given in the column headed 'Available spare' and state the size and type of ball valve required.

Example: 1 - Seat and stem seal set for a Spirax Sarco 1/2" M10S2FB ball valve.

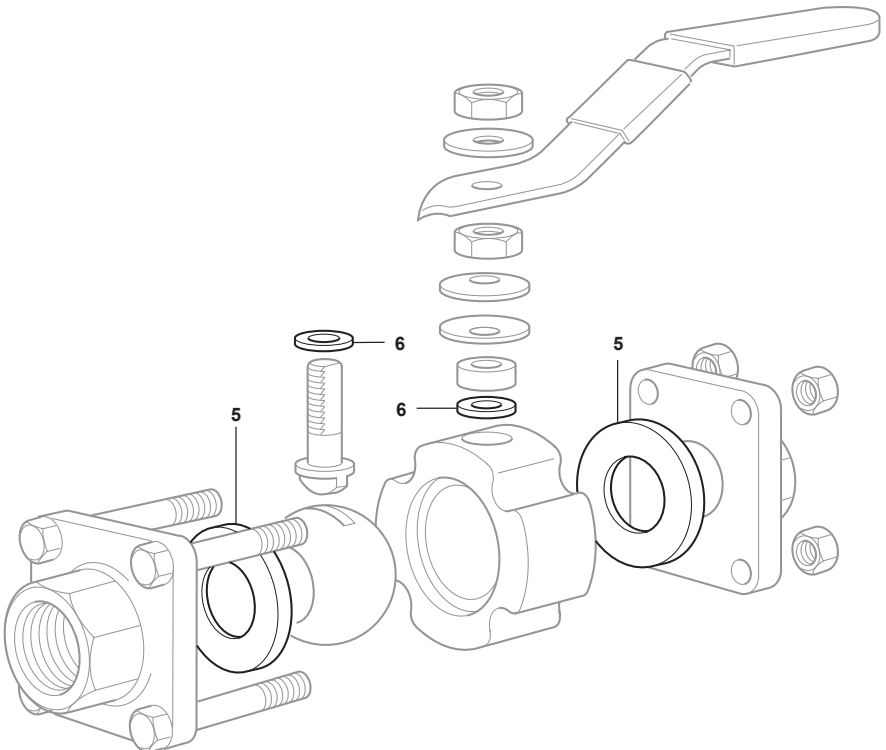

Fig. 5 M10S screwed version shown

