

LCV3, LCV4, LCV6 and LCV7
Lift Check Valves
Installation and Maintenance Instructions

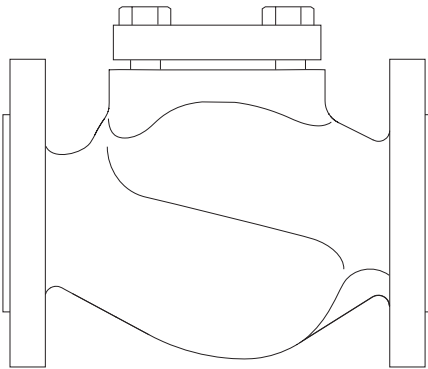

- 1. Safety information*
- 2. General product information*
- 3. Installation*
- 4. Commissioning*
- 5. Operation*
- 6. Spare parts and Maintenance*

1. Safety information

Safe operation of these products can only be guaranteed if they are properly installed, commissioned, used and maintained by qualified personnel (see Section 1.11) in compliance with the operating instructions. General installation and safety instructions for pipeline and plant construction, as well as the proper use of tools and safety equipment must also be complied with.

1.1 Intended use

Referring to the Installation and Maintenance Instructions, name-plate and Technical Information Sheet, check that the product is suitable for the intended use/application. The products listed below comply with the requirements of the European Pressure Equipment Directive 97/23/EC and carry the CE mark when so required. It should be noted that products rated as 'SEP' are required by the Directive not to carry the CE mark. The products fall within the following Pressure Equipment Directive categories:

Unit	Sizes	Connections	Group 1 Gases	Group 2 Gases	Group 1 Liquids	Group 2 Liquids
LCV3	DN15 to DN25	All	SEP	SEP	SEP	SEP
	DN32 to DN50	All	1	SEP	SEP	SEP
	DN65 to DN100	All	2	1	SEP	SEP
LCV4	DN15 to DN25	All	SEP	SEP	SEP	SEP
	DN32	All	2	SEP	SEP	SEP
	DN40 to DN50	ASME 150	1	SEP	SEP	SEP
		JIS / KS 10				
		PN25 and PN40	2	1	SEP	SEP
	JIS / KS 20					
		Others	2	1	2	SEP
	DN65 to DN100	All	2	1	2	SEP
LCV6	DN15 to DN25	All	SEP	SEP	SEP	SEP
	DN32	All	2	SEP	SEP	SEP
	DN40 to DN50	ASME 150	1	SEP	SEP	SEP
		JIS / KS 10				
		BSP	2	1	SEP	SEP
		PN16, PN25 and PN40				
		JIS / KS 20				
		Others	2	1	2	SEP
	DN65 to DN100	All	SEP	1	2	SEP

Unit	Sizes	Connections	Group 1 Gases	Group 2 Gases	Group 1 Liquids	Group 2 Liquids
LCV7	DN15 to DN25	All	SEP	SEP	SEP	SEP
		ASME 250	2	1	SEP	SEP
	DN32 to DN40	Others	1	SEP	SEP	SEP
		ASME 125	1	SEP	SEP	SEP
	Others	2	1	SEP	SEP	
	DN50 to DN65	ASME 250	2	1	2	SEP
		Others	2	1	SEP	SEP
		DN80	ASME 125	2	1	SEP
	PN16					
	JIS / KS 10					
	Others					
DN100	ASME 125	2	1	SEP	SEP	
	PN16					
	JIS / KS 10					
	Others					

- i) These products have been specifically designed for use on steam, air or water / condensate as stated in Groups 1 and 2 of the above mentioned Pressure Equipment Directive. The products' use on other fluids may be possible but, if this is contemplated, Spirax Sarco should be contacted to confirm the suitability of the product for the application being considered.
- ii) Check material suitability, pressure and temperature and their maximum and minimum values. If the maximum operating limits of the product are lower than those of the system in which it is being fitted, or if malfunction of the product could result in a dangerous overpressure or overtemperature occurrence, ensure a safety device is included in the system to prevent such over-limit situations.
- iii) Determine the correct installation situation and direction of fluid flow.
- iv) Spirax Sarco products are not intended to withstand external stresses that may be induced by any system to which they are fitted. It is the responsibility of the installer to consider these stresses and take adequate precautions to minimise them.
- v) Remove protection covers from all connections and protective film from all name-plates, where appropriate, before installation on steam or other high temperature applications.

1.2 Access

Ensure safe access and if necessary a safe working platform (suitably guarded) before attempting to work on the product. Arrange suitable lifting gear if required.

1.3 Lighting

Ensure adequate lighting, particularly where detailed or intricate work is required.

1.4 Hazardous liquids or gases in the pipeline

Consider what is in the pipeline or what may have been in the pipeline at some previous time. Consider: flammable materials, substances hazardous to health, extremes of temperature.

1.5 Hazardous environment around the product

Consider: explosion risk areas, lack of oxygen (e.g. tanks, pits), dangerous gases, extremes of temperature, hot surfaces, fire hazard (e.g. during welding), excessive noise, moving machinery.

1.6 Isolation

Consider the effect on the complete system of the work proposed. Will any proposed action (e.g. closing isolation valves, electrical isolation) put any other part of the system or any personnel at risk?

Dangers might include isolation of vents or protective devices or the rendering ineffective of controls or alarms. Ensure isolation valves are turned on and off in a gradual way to avoid system shocks.

1.7 Pressure

Before attempting any maintenance consider what is or may have been in the pipeline. Ensure that any pressure is isolated and safely vented to atmospheric pressure before attempting to maintain the product, this is easily achieved by fitting Spirax Sarco depressurisation valves type DV (see separate literature for details) and consider double isolation (double block and bleed) and the locking or labelling of closed valves. Do not assume that the system is depressurised even when a pressure gauge indicates zero.

1.8 Temperature

Allow time for temperature to normalise after isolation to avoid the danger of burns and consider whether protective clothing (including safety glasses) is required.

1.9 Tools and consumables

Before starting work ensure that you have suitable tools and/or consumables available. Use only genuine Spirax Sarco replacement parts.

1.10 Protective clothing

Consider whether you and/or others in the vicinity require any protective clothing to protect against the hazards of, for example, chemicals, high/low temperature, radiation, noise, falling objects, and dangers to eyes and face.

1.11 Permits to work

All work must be carried out or be supervised by a suitably competent person. Installation and operating personnel should be trained in the correct use of the product according to the Installation and Maintenance Instructions.

Where a formal 'permit to work' system is in force it must be complied with. Where there is no such system, it is recommended that a responsible person should know what work is going on and, where necessary, arrange to have an assistant whose primary responsibility is safety.

Post 'warning notices' if necessary.

1.12 Handling

Manual handling of large and/or heavy products may present a risk of injury. Lifting, pushing, pulling, carrying or supporting a load by bodily force can cause injury particularly to the back. You are advised to assess the risks taking into account the task, the individual, the load and the working environment and use the appropriate handling method depending on the circumstances of the work being done.

1.13 Residual hazards

In normal use the external surface of the product may be very hot. If used at the maximum permitted operating conditions the surface temperature of some products may reach temperatures of 400°C (752°F).

Many products are not self-draining. Take due care when dismantling or removing the product from an installation (refer to 'Maintenance instructions').

1.14 Freezing

Provision must be made to protect products which are not self-draining against frost damage in environments where they may be exposed to temperatures below freezing point.

1.15 Disposal

Unless otherwise stated in the Installation and Maintenance Instructions, these products are recyclable and no ecological hazard is anticipated with their disposal providing due care is taken.

1.16 Returning products

Customers and stockists are reminded that under EC Health, Safety and Environment Law, when returning products to Spirax Sarco they must provide information on any hazards and the precautions to be taken due to contamination residues or mechanical damage which may present a health, safety or environmental risk. This information must be provided in writing including Health and Safety data sheets relating to any substances identified as hazardous or potentially hazardous.

— 2. General product information —

2.1 General description

The LCV3, LCV4, LCV6 and LCV7 lift check valves are designed in accordance with EN 12516 and ASME B16.34 to prevent reverse flow in the installations.

Available types:

LCV3 Cast iron bodied with stainless steel internals.

LCV4 Cast steel bodied with stainless steel internals.

LCV6 Stainless steel bodied with stainless steel internals.

LCV7 SG iron bodied with stainless steel internals.

Optional for the LCV4:

High temperature bolting (stainless steel A2-70).

Standards

These products fully comply with the requirements of the European Pressure Equipment Directive 97/23/EC and carries the **CE** mark when so required.

Standard shut-off

This range of lift check valves conform to EN 12266-1: 2003 Rate F.

Certification

With the exception of the LCV3 these products are available with certification to EN 10204 3.1. **Note:** All certification / inspection requirements must be stated at the time of order placement.

Note:

For further information see the following Technical Information Sheet TI-P029-16.

2.2 Sizes and pipe connections

Unit		LCV3			LCV4		
Connections		PN16 JIS / KS10	ASME 125	BSP NPT	PN40 JIS / KS 20	ASME 150 ASME 300	NPT SW
DN15	1/2"	•		•	•	•	•
DN20	3/4"	•		•	•	•	•
DN25	1"	•	•	•	•	•	•
DN32	1 1/4"	•		•	•		•
DN40	1 1/2"	•	•	•	•	•	•
DN50	2"	•	•	•	•	•	•
DN65	2 1/2"	•	•		•	•	
DN80	3"	•	•		•	•	
DN100	4"	•	•		•	•	

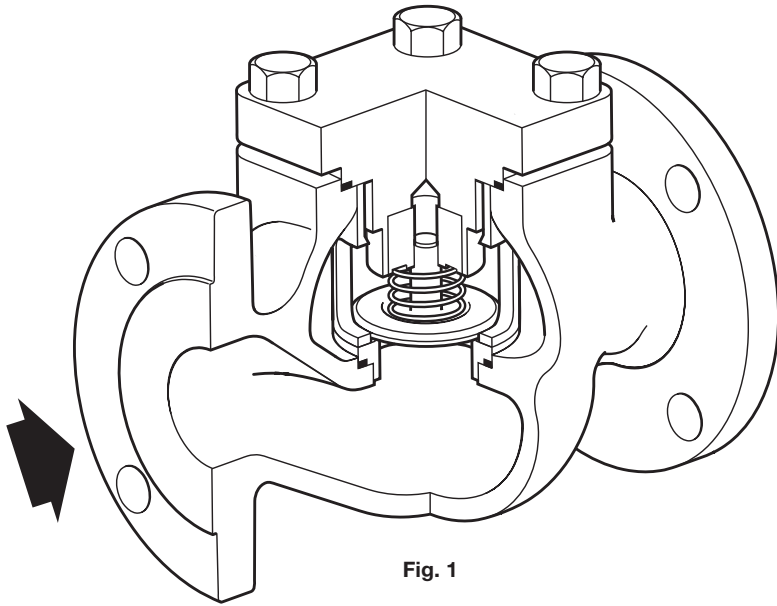
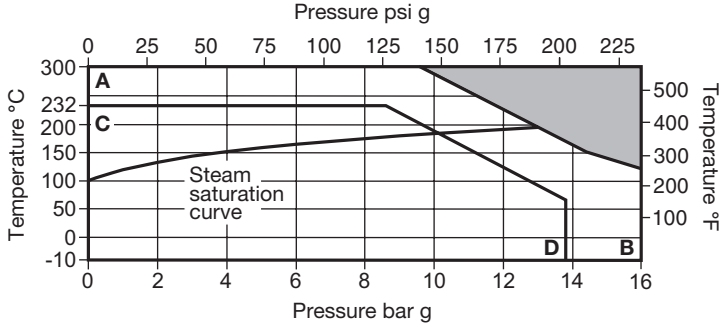



Fig. 1

2.2 Sizes and pipe connections

Unit		LCV6			LCV7		
Connections		PN40 JIS / KS20	ASME 150 ASME 300	BSP NPT SW	PN16 PN25 JIS / KS10	ASME 125 ASME 250	BSP NPT
DN15	½"	•	•	•	•		•
DN20	¾"	•	•	•	•		•
DN25	1"	•	•	•	•	•	•
DN32	1¼"	•		•	•		•
DN40	1½"	•	•	•	•	•	•
DN50	2"	•	•	•	•	•	•
DN65	2½"	•	•		•	•	
DN80	3"	•	•		•	•	
DN100	4"	•	•		•	•	

2.3 Pressure / temperature limits - LCV3



 The product **must not** be used in this region.

A - B Screwed BSP and flanged EN 1092 PN16.

C - D Screwed NPT, socket weld and flanged ASME 125.

Flanged JIS / KS 10

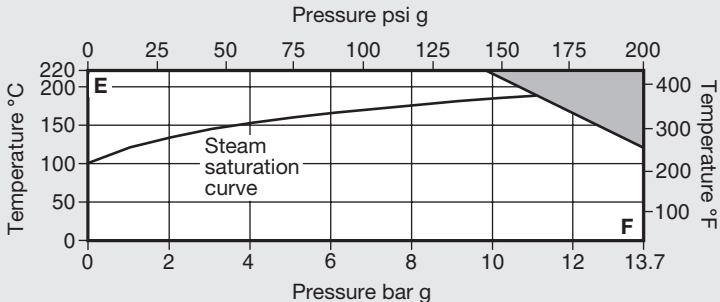

 The product **must not** be used in this region.

E - F Flanged JIS / KS 10.

Body design conditions		JIS / KS 10	
PMA	Maximum allowable pressure	13.7 bar g @ 120°C	(199 psi g @ 248°F)
TMA	Maximum allowable temperature	220°C @ 9.8 bar g	(428°F @ 142 psi g)
	Minimum allowable temperature	0°C	(32°F)
PMO	Maximum operating pressure for saturated steam service	11.2 bar g	(162 psi g)
TMO	Maximum operating temperature	220°C @ 9.8 bar g	(428°F @ 142 psi g)
	Minimum operating temperature	0°C	(32°F)
Note: For lower operating temperatures consult Spirax Sarco.			
Designed for a maximum cold hydraulic test pressure of:		20 bar g	(290 psi g)

Screwed and Flanged EN 1092 PN16

Body design conditions			PN16
PMA	Maximum allowable pressure	16 bar g @ 120°C	(232 psi g @ 248°F)
TMA	Maximum allowable temperature	300°C @ 9.6 bar g	(572°F @ 139 psi g)
Minimum allowable temperature			-10°C (14°F)
PMO	Maximum operating pressure for saturated steam service	13 bar g	(189 psi g)
TMO	Maximum operating temperature	300°C @ 9.6 bar g	(572°F @ 139 psi g)
Minimum operating temperature			-10°C (14°F)
Note: For lower operating temperatures consult Spirax Sarco.			
Designed for a maximum cold hydraulic test pressure of:			24 bar g (348 psi g)

Flanged ASME 125

Body design conditions			ASME 125
PMA	Maximum allowable pressure	13.8 bar g @ 65°C	(200 psi g @ 149°F)
TMA	Maximum allowable temperature	232°C @ 8.6 bar g	(449°F @ 125 psi g)
Minimum allowable temperature			-10°C (14°F)
PMO	Maximum operating pressure for saturated steam service	10 bar g	(145 psi g)
TMO	Maximum operating temperature	232°C @ 8.6 bar g	(449°F @ 125 psi g)
Minimum operating temperature			-10°C (14°F)
Note: For lower operating temperatures consult Spirax Sarco.			
Designed for a maximum cold hydraulic test pressure of			20.5 bar g (297 psi g)

2.3 Pressure / temperature limits - LCV4

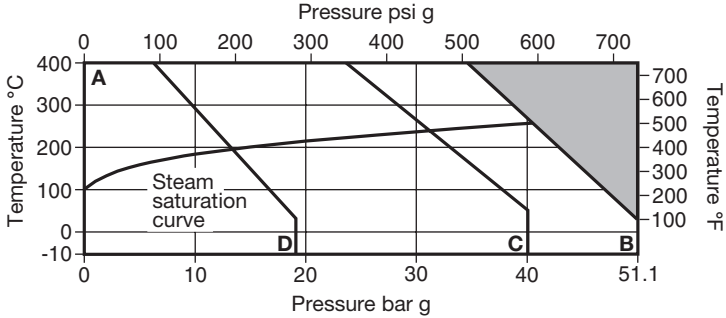

 The product **must not** be used in this region.

A - B Screwed NPT, socket weld and flanged ASME 300.

A - C Flanged EN 1092 PN40.

A - D Flanged ASME 150.

Flanged JIS / KS 20

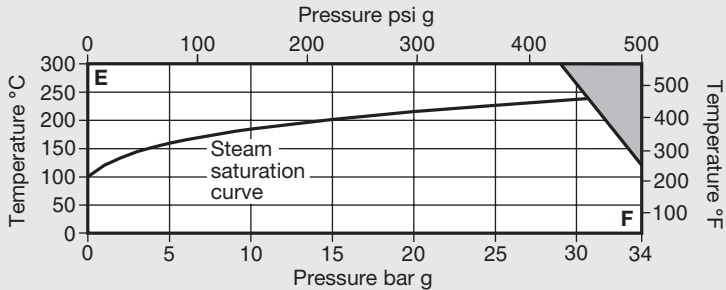

 The product **must not** be used in this region.

E - F Flanged JIS / KS 20.

Body design conditions		JIS / KS 20	
PMA	Maximum allowable pressure	34 bar g @ 120°C	(493 psi g @ 248°F)
TMA	Maximum allowable temperature	300°C @ 32 bar g	(572°F @ 464 psi g)
	Minimum allowable temperature	0°C	(32°F)
PMO	Maximum operating pressure for saturated steam service	30 bar g	(435 psi g)
TMO	Maximum operating temperature	300°C @ 32 bar g	(572°F @ 464 psi g)
	Minimum operating temperature	0°C	(32°F)
Note: For lower operating temperatures consult Spirax Sarco.			
Designed for a maximum cold hydraulic test pressure of:		51 bar g	(739 psi g)

Flanged EN 1092 PN40

Body design conditions			PN40
PMA	Maximum allowable pressure	40 bar g @ 50°C	(580 psi g @ 122°F)
TMA	Maximum allowable temperature	300°C @ 27.6 bar g	(572°F @ 400 psi g)
	Maximum allowable temperature with high temperature bolting	400°C @ 23.8 bar g	(752°F @ 345 psi g)
Minimum allowable temperature		-10°C	(14°F)
PMO	Maximum operating pressure for saturated steam service	31.1 bar g	(451 psi g)
TMO	Maximum operating temperature	300°C @ 27.6 bar g	(572°F @ 400 psi g)
	Maximum operating temperature with high temperature bolting	400°C @ 23.8 bar g	(752°F @ 345 psi g)
Minimum operating temperature		-10°C	(14°F)
Note: For lower operating temperatures consult Spirax Sarco.			
Designed for a maximum cold hydraulic test pressure of: 60 bar g			(870 psi g)

Flanged ASME 150

Body design conditions			ASME 150
PMA	Maximum allowable pressure	19.3 bar g @ 38°C	(280 psi g @ 100°F)
TMA	Maximum allowable temperature	300°C @ 10.2 bar g	(572°F @ 148 psi g)
	Maximum allowable temperature with high temperature bolting	400°C @ 6.5 bar g	(752°F @ 94 psi g)
Minimum allowable temperature		-10°C	(14°F)
PMO	Maximum operating pressure for saturated steam service	13.9 bar g	(201 psi g)
TMO	Maximum operating temperature	300°C @ 10.2 bar g	(572°F @ 148 psi g)
	Maximum operating temperature with high temperature bolting	400°C @ 6.5 bar g	(752°F @ 94 psi g)
Minimum operating temperature		-10°C	(14°F)
Note: For lower operating temperatures consult Spirax Sarco.			
Designed for a maximum cold hydraulic test pressure of: 30 bar g			(435 psi g)

Screwed NPT, Socket weld and Flanged ASME 300

Body design conditions			ASME 300
PMA	Maximum allowable pressure	51.1 bar g @ 38°C	(741 psi g @ 100°F)
TMA	Maximum allowable temperature	300°C @ 39.8 bar g	(572°F @ 577 psi g)
	Maximum allowable temperature with high temperature bolting	400°C @ 34.7 bar g	(752°F @ 503 psi g)
Minimum allowable temperature		-10°C	(14°F)
PMO	Maximum operating pressure for saturated steam service	41.8 bar g	(606 psi g)
TMO	Maximum operating temperature	300°C @ 39.8 bar g	(572°F @ 577 psi g)
	Maximum operating temperature with high temperature bolting	400°C @ 34.7 bar g	(752°F @ 503 psi g)
Minimum operating temperature		-10°C	(14°F)
Note: For lower operating temperatures consult Spirax Sarco.			
Designed for a maximum cold hydraulic test pressure of: 77 bar g			(1 117 psi g)

2.3 Pressure / temperature limits - LCV6

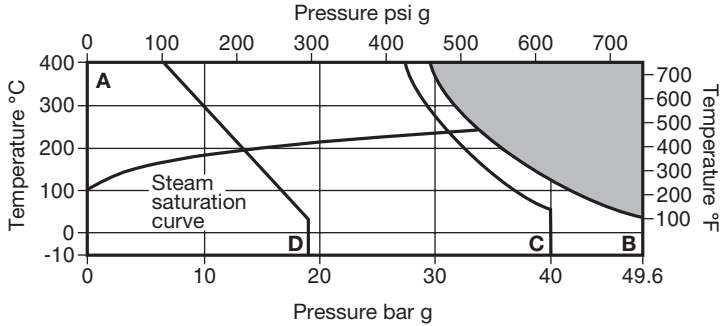

 The product **must not** be used in this region.

A - B Screwed NPT, socket weld and flanged ASME 300.

A - C Screwed BSP and flanged EN 1092 PN40.

A - D Flanged ASME 150.

Flanged JIS / KS 20

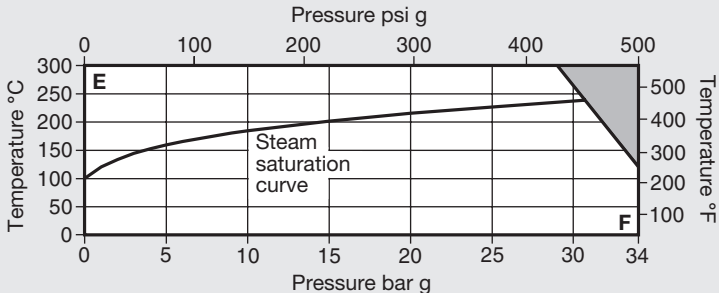

 The product **must not** be used in this region.

E - F Flanged JIS / KS 20.

Body design conditions		JIS / KS 20	
PMA	Maximum allowable pressure	34 bar g @ 120°C	(493 psi g @ 248°F)
TMA	Maximum allowable temperature	300°C @ 32 bar g	(572°F @ 464 psi g)
	Minimum allowable temperature	0°C	(32°F)
PMO	Maximum operating pressure for saturated steam service	23.5 bar g	(431 psi g)
TMO	Maximum operating temperature	300°C @ 32 bar g	(572°F @ 464 psi g)
	Minimum operating temperature	0°C	(32°F)
Note: For lower operating temperatures consult Spirax Sarco.			
Designed for a maximum cold hydraulic test pressure of:		51 bar g	(739 psi g)

Screwed BSP and Flanged EN 1092 PN40

Body design conditions		PN40	
PMA	Maximum allowable pressure	40 bar g @ 50°C	(580 psi g @ 122°F)
TMA	Maximum allowable temperature	400°C @ 27.4 bar g	(752°F @ 397 psi g)
Minimum allowable temperature		-10°C	(14°F)
PMO	Maximum operating pressure for saturated steam service	32.3 bar g	(468 psi g)
TMO	Maximum operating temperature	400°C @ 27.4 bar g	(752°F @ 397 psi g)
Minimum operating temperature		-10°C	(14°F)
Note: For lower operating temperatures consult Spirax Sarco.			
Designed for a maximum cold hydraulic test pressure of:		60 bar g	(870 psi g)

Screwed NPT, Socket weld and Flanged ASME 300

Body design conditions		ASME 300	
PMA	Maximum allowable pressure	49.6 bar g @ 38°C	(719 psi g @ 100°F)
TMA	Maximum allowable temperature	400°C @ 29.4 bar g	(752°F @ 426 psi g)
Minimum allowable temperature		-10°C	(14°F)
PMO	Maximum operating pressure for saturated steam service	34 bar g	(493 psi g)
TMO	Maximum operating temperature	400°C @ 29.4 bar g	(752°F @ 426 psi g)
Minimum operating temperature		-10°C	(14°F)
Note: For lower operating temperatures consult Spirax Sarco.			
Designed for a maximum cold hydraulic test pressure of:		76 bar g	(1 102 psi g)

Flanged ASME 150

Body design conditions		ASME 150	
PMA	Maximum allowable pressure	19 bar g @ 38°C	(275 psi g @ 100°F)
TMA	Maximum allowable temperature	400°C @ 6.5 bar g	(752°F @ 94 psi g)
Minimum allowable temperature		-10°C	(14°F)
PMO	Maximum operating pressure for saturated steam service	13.8 bar g	(200 psi g)
TMO	Maximum operating temperature	400°C @ 6.5 bar g	(752°F @ 94 psi g)
Minimum operating temperature		-10°C	(14°F)
Note: For lower operating temperatures consult Spirax Sarco.			
Designed for a maximum cold hydraulic test pressure of:		30 bar g	(435 psi g)

2.3 Pressure / temperature limits - LCV7

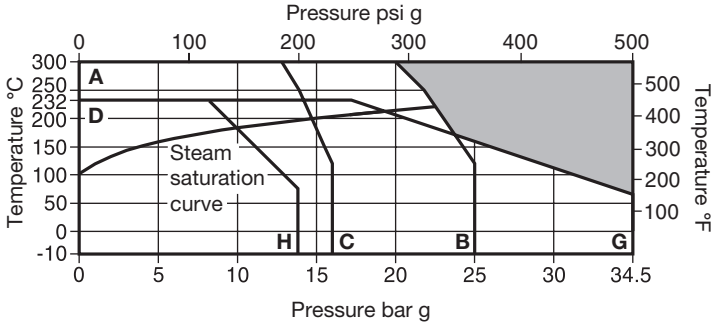

The product **must not** be used in this region.

- A - B** Screwed BSP and flanged EN 1092 PN25.
- A - C** Screwed NPT and flanged EN 1092 PN16.
- D - G** Flanged ASME 250.
- D - H** Flanged ASME 125.

Flanged JIS / KS 10

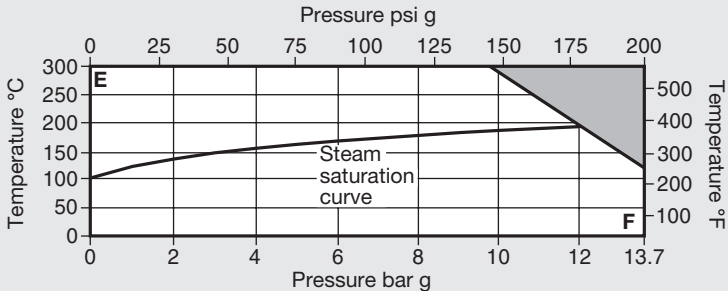

The product **must not** be used in this region.

- E - F** Flanged JIS / KS 10.

Body design conditions		JIS / KS 10	
PMA	Maximum allowable pressure	13.7 bar g @ 120°C	(199 psi g @ 248°F)
TMA	Maximum allowable temperature	300°C @ 9.8 bar g	(572°F @ 142 psi g)
	Minimum allowable temperature	0°C	(32°F)
PMO	Maximum operating pressure for saturated steam service	12.3 bar g	(178 psi g)
TMO	Maximum operating temperature	300°C @ 9.8 bar g	(572°F @ 142 psi g)
	Minimum operating temperature	0°C	(32°F)
Note: For lower operating temperatures consult Spirax Sarco.			
		Designed for a maximum cold hydraulic test pressure of:	20 bar g (290 psi g)

Flanged EN 1092 PN16

Body design conditions			PN16
PMA	Maximum allowable pressure	16 bar g @ 120°C	(232 psi g @ 248°F)
TMA	Maximum allowable temperature	300°C @ 12.8 bar g	(572°F @ 185 psi g)
Minimum allowable temperature			-10°C (14°F)
PMO	Maximum operating pressure for saturated steam service	14.7 bar g	(213 psi g)
TMO	Maximum operating temperature	300°C @ 12.8 bar g	(572°F @ 185 psi g)
Minimum operating temperature			-10°C (14°F)
Note: For lower operating temperatures consult Spirax Sarco.			
Designed for a maximum cold hydraulic test pressure of:			24 bar g (348 psi g)

Screwed BSP and Flanged EN 1092 PN25

Body design conditions			PN25
PMA	Maximum allowable pressure	25 bar g @ 120°C	(462 psi g @ 248°F)
TMA	Maximum allowable temperature	300°C @ 20 bar g	(572°F @ 290 psi g)
Minimum allowable temperature			-10°C (14°F)
PMO	Maximum operating pressure for saturated steam service	22.5 bar g	(326 psi g)
TMO	Maximum operating temperature	300°C @ 20 bar g	(572°F @ 290 psi g)
Minimum operating temperature			-10°C (14°F)
Note: For lower operating temperatures consult Spirax Sarco.			
Designed for a maximum cold hydraulic test pressure of:			38 bar g (551 psi g)

Flanged ASME 125

Body design conditions			ASME 125
PMA	Maximum allowable pressure	13.8 bar g @ 65°C	(200 psi g @ 149°F)
TMA	Maximum allowable temperature	232°C @ 8.6 bar g	(449°F @ 125 psi g)
Minimum allowable temperature			-10°C (14°F)
PMO	Maximum operating pressure for saturated steam service	10 bar g	(145 psi g)
TMO	Maximum operating temperature	232°C @ 8.6 bar g	(449°F @ 125 psi g)
Minimum operating temperature			-10°C (14°F)
Note: For lower operating temperatures consult Spirax Sarco.			
Designed for a maximum cold hydraulic test pressure of:			20.5 bar g (297 psi g)

Screwed NPT and Flanged ASME 250

Body design conditions			ASME 250
PMA	Maximum allowable pressure	34.5 bar g @ 65°C	(500 psi g @ 149°F)
TMA	Maximum allowable temperature	232°C @ 17.2 bar g	(449°F @ 249 psi g)
Minimum allowable temperature			-10°C (14°F)
PMO	Maximum operating pressure for saturated steam service	19.4 bar g	(281 psi g)
TMO	Maximum operating temperature	232°C @ 17.2 bar g	(449°F @ 249 psi g)
Minimum operating temperature			-10°C (14°F)
Note: For lower operating temperatures consult Spirax Sarco.			
Designed for a maximum cold hydraulic test pressure of:			52 bar g (754 psi g)

2.4 Dimensions (approximate) in mm

Please note: Flanged ASME versions are (approximate) in inches

Dimension A

Connection	Screwed BSP Socket weld	Flanged PN40 PN16 PN25 JIS 10/ KS 10 JIS 20/ KS 20	Screwed NPT	Flanged		Flanged ASME 250 ASME 300
				ASME 125 LCV3	LCV7	
DN15 1/2"	130	130	6 1/2"	7 1/4"		7 1/2"
DN20 3/4"	155	150	6 1/2"	7 1/4"		7 1/2"
DN25 1"	160	160	7 3/4"	7 1/4"	7 1/4"	7 3/4"
DN32 1 1/4"	185	180	8 1/2"			
DN40 1 1/2"	205	200	9 1/4"	8 3/4"	8 3/4"	9 1/4"
DN50 2"	230	230	10 1/2"	10"	10"	10 1/2"
DN65 2 1/2"		290		10 1/2"	10 1/2"	11 1/2"
DN80 3"		310		11 3/4"	11 3/4"	12 1/2"
DN100 4"		350		13 3/4"	13 3/4"	14 1/2"

Dimension B

Connection	Screwed BSP Socket weld	Flanged PN40 PN16 PN25 JIS 10/ KS 10 JIS 20/ KS 20	Screwed NPT	Flanged		Flanged ASME 250 ASME 300
				ASME 125 LCV3	LCV7	
DN15 1/2"	88	88	4"	4"	4"	4"
DN20 3/4"	88	88	4"	4"	4"	4"
DN25 1"	88	88	4"	4"	4"	4"
DN32 1 1/4"	117	117	5 3/16"			
DN40 1 1/2"	117	117	5 3/16"	5 3/16"	5 3/16"	5 3/16"
DN50 2"	117	117	5 3/16"	5 3/16"	5 3/16"	5 3/16"
DN65 2 1/2"		166		7 7/8"	7 7/8"	7 7/8"
DN80 3"		166		7 7/8"	7 7/8"	7 7/8"
DN100 4"		180		8 1/2"	8 1/2"	8 1/2"

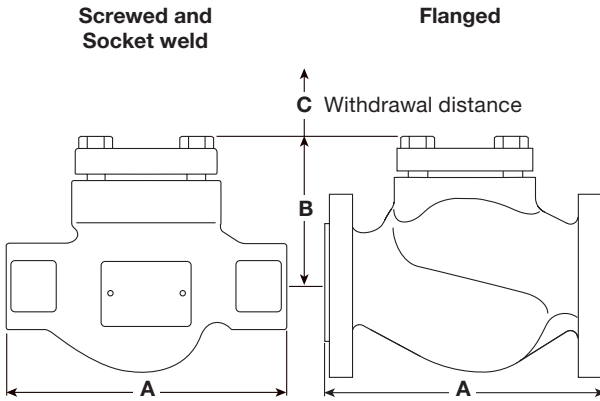

Dimension C

Connection		All sizes
DN15	½"	143
DN20	¾"	143
DN25	1"	143
DN32	1¼"	182
DN40	1½"	182
DN50	2"	182
DN65	2½"	260
DN80	3"	260
DN100	4"	300

Fig. 2

2.5 Product name-plate

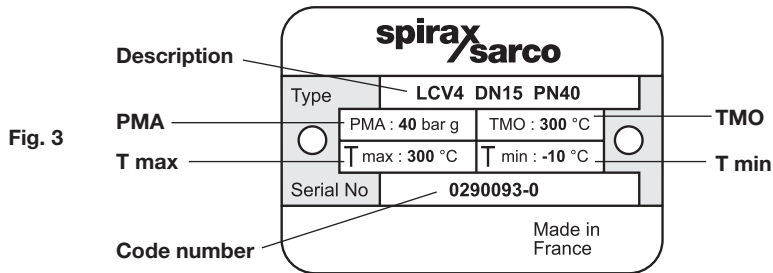

Fig. 3

2.6 Weights (approximate) in kg

Unit		LCV3		LCV4		LCV6		LCV7	
		Flanged	Screwed	Flanged	Screwed Socket weld	Flanged	Screwed Socket weld	Flanged	Screwed
DN15	½"	4.30	3.10	5.05	3.65	5.19	3.79	4.64	3.24
DN20	¾"	5.50	4.10	6.43	5.33	6.60	5.50	5.89	4.29
DN25	1"	5.82	4.10	6.58	4.18	6.77	4.37	6.04	3.74
DN32	1¼"	10.23	7.20	12.89	9.59	13.37	10.07	11.99	8.69
DN40	1½"	11.43	8.00	14.35	9.55	14.77	9.97	13.18	9.28
DN50	2"	14.96	10.50	16.86	12.06	17.51	12.71	15.65	10.65
DN65	2½"	27.04		32.25		33.13		29.53	
DN80	3"	29.47		36.02		37.00		33.00	
DN100	4"	48.93		52.06		53.47		48.82	

3. Installation

Note: Before actioning any installation observe the 'Safety information' in Section 1.

Referring to the Installation and Maintenance Instructions, name-plate and Technical Information Sheet, check that the product is suitable for the intended installation:

- 3.1** Check materials, pressure and temperature and their maximum values. If the maximum operating limit of the product is lower than that of the system in which it is being fitted, ensure that a safety device is included in the system to prevent overpressurisation.
- 3.2** Determine the correct installation situation and the direction of fluid flow.
- 3.3** Remove protective covers from all connections and the protective film from all name-plates, where appropriate, before installation on steam or other high temperature applications.
- 3.4** The LCV is designed for installation in horizontal and vertical pipework (see Figure 4).

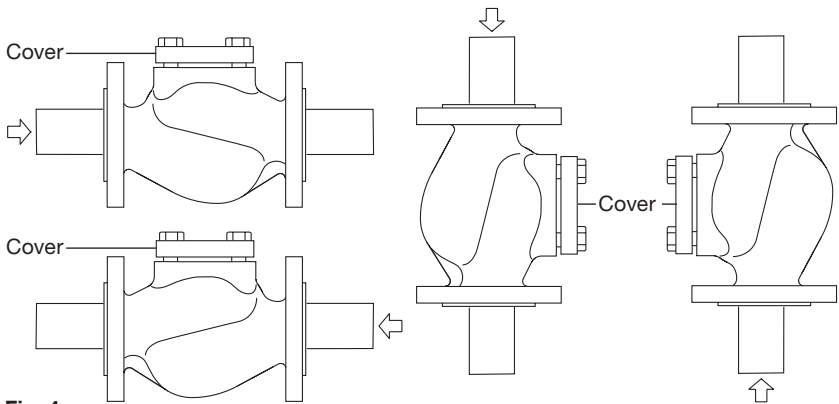

Fig. 4

- 3.5** Always fit a non-return (check) valve downstream of any steam traps which discharge into condensate return lines where backpressure is experienced. This is most commonly caused by a rising condensate line. The check valve will prevent the steam space flooding when the inlet pressure is reduced or the steam is shut off.
- 3.6** When the LCV is installed after a blast action steam trap (thermodynamic and inverted bucket), it should be positioned at least 1 m (3 ft) downstream of the outlet.
- 3.7** Isolation valves must be installed to allow for safe maintenance and check valve replacement.
- 3.8** Open isolation valves slowly until normal operating conditions are achieved.
- 3.9** Check for leaks and correct operation.
- 3.10** Ensure adequate space is left to remove the cover from the body for maintenance - See Section 2.4, minimum withdrawal distance 'C'.
- 3.11** Welding into the pipeline - LCV4 and LCV6 socket weld connections. For specific weld procedures consult the relevant National and International welding standards.

Note: If a trap is to discharge to atmosphere ensure it is to a safe place as the discharging fluid may be at a temperature of 100°C (212°F).

4. Commissioning

After installation or maintenance ensure that the system is fully functional. Carry out tests on any alarms or protective devices.

5. Operation

LCV check valves are opened by the pressure of the fluid and closed by the spring as soon as the flow ceases and before the reverse flow occurs.

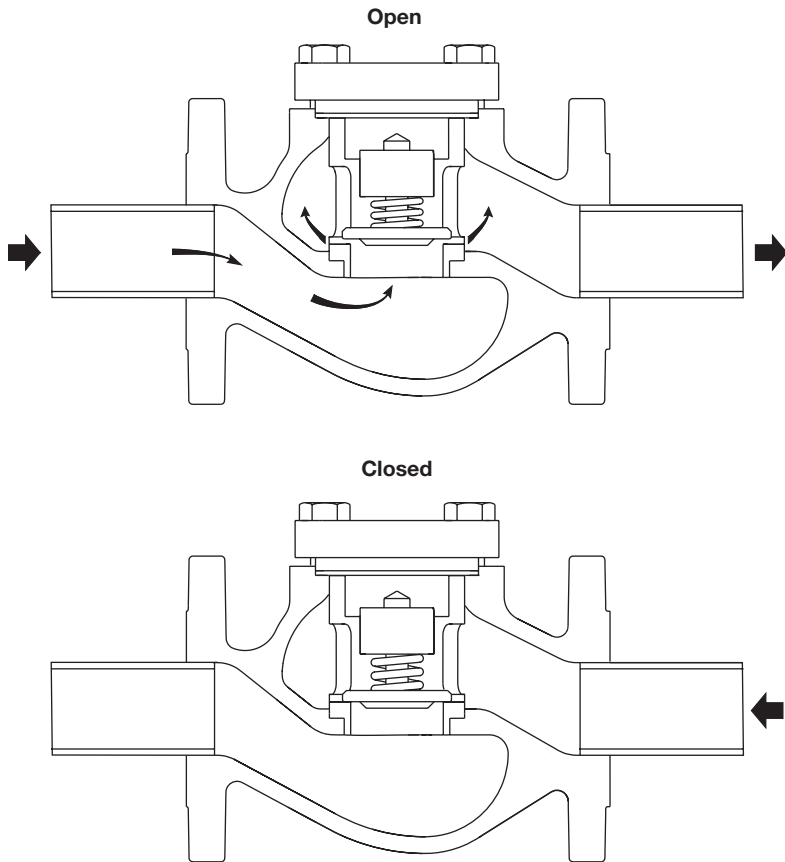

Fig. 5

— 6. Spare parts and Maintenance —

6.1 Spare parts

The spare parts available are shown in solid outline. Parts drawn in broken line are not supplied as spares.

Available spares

LCV Gaskets kit (Cover gasket and seat gasket)	Spare 1
LCV Internals kit (Cover gasket, seat gasket, spring, disc and seat)	Spare 2

How to order spares

Always order spares by using the description given in the column headed 'Available spares' and state the size and type of trap. Always order spares by using the description of the LCV and Spare 1 or Spare 2.

Example: 1 off LCV Internals kit – Spare 2, for a Spirax Sarco DN15 LCV4 lift check valve having flanged EN 1092 PN40 connections.

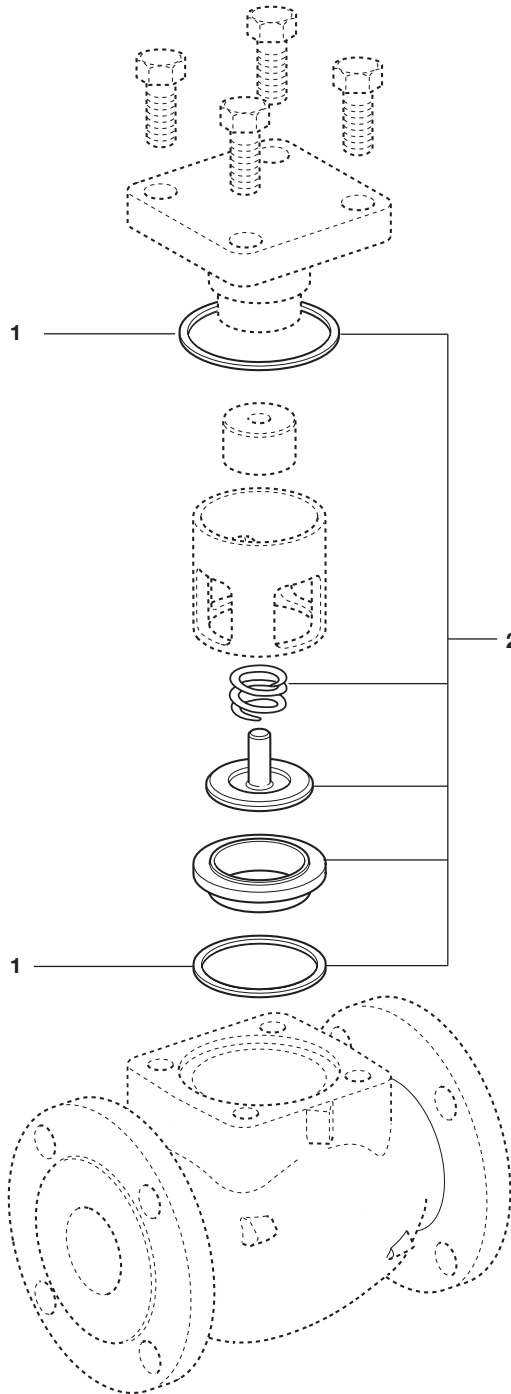

Fig. 6

6.2 Maintenance

Note:

Before actioning any maintenance programme observe the 'Safety information' in Section 1.



6.2.1 How to renew the cover gasket (3a) and seat gasket (3b):

- Isolate the LCV and allow the pressure and temperature to reduce to ambient conditions.
- After isolation, unscrew the bolts (8) and remove the cover (1), old gasket (3a) and cage (9).
- Remove the spring (7) and the disc (6).
- Remove the seat (4) and the seat gasket (3b).
- Carefully clean the recess.
- Refit new seat gasket (3b) and cover gasket (3a).
- Replace the internals - seat (4) and cage (9) after refitting the disc (6) and spring (7).
- Replace the cover (1) and the bolts (8) (for the LCV6 version you must lubricate the screws when refitting the bolt) and tighten to the recommended torque (see Table 1).
- After maintenance has been completed, isolation valves should be opened slowly to allow pressure and temperature to build up in a controlled manner.
- Check for leaks.

6.2.2 How to renew the internal parts - Disc (6), Spring (7) and Seat (4):

- Isolate the LCV and allow the pressure and temperature to reduce to ambient conditions.
- After isolation, unscrew the bolts (8) and remove the cover (1), old gasket (3a) and cage (9).
- Remove the spring (7) and the disc (6).
- Remove the seat (4) and the seat gasket (3b).
- Carefully clean the recess.
- Refit new seat gasket (3b) and cover gasket (3a).
- Refit new internals - Seat (4), Disc (6) and Spring (7).
- Replace the cage (9).
- Replace the cover (1) and the bolts (8) (for the LCV6 version you must lubricate the screws when refitting the bolt) and tighten to the recommended torque (see Table 1).
- After maintenance has been completed, isolation valves should be opened slowly to allow pressure and temperature to build up in a controlled manner.
- Check for leaks.

Table 1 Recommended tightening torque

Item	Size					Torque N m (lbf ft)
		EN	ASME	EN	ASME	
8	DN15 to DN25 (½" to 1")	LCV3 17 A/F	⅞" A/F	LCV3 M10	½" - 13 UNC	40 - 50 (30 - 37)
		Others 19 A/F		Others M12		
	DN32 to DN50 (1¼" to 2")	LCV3 19 A/F	1⅛" A/F	LCV3 M12	⅝" - 11 UNC	80 - 90 (59 - 66)
		Others 24 A/F		Others M16		
DN65 to DN80 (2½" to 3")	24 A/F	1¼" A/F	M16	¾" - 9 UNC	90 - 100 (66 - 74)	
DN100 (4")	24 A/F	1⅛" A/F	M16	⅝" - 11 UNC	70 - 80 (52 - 59)	

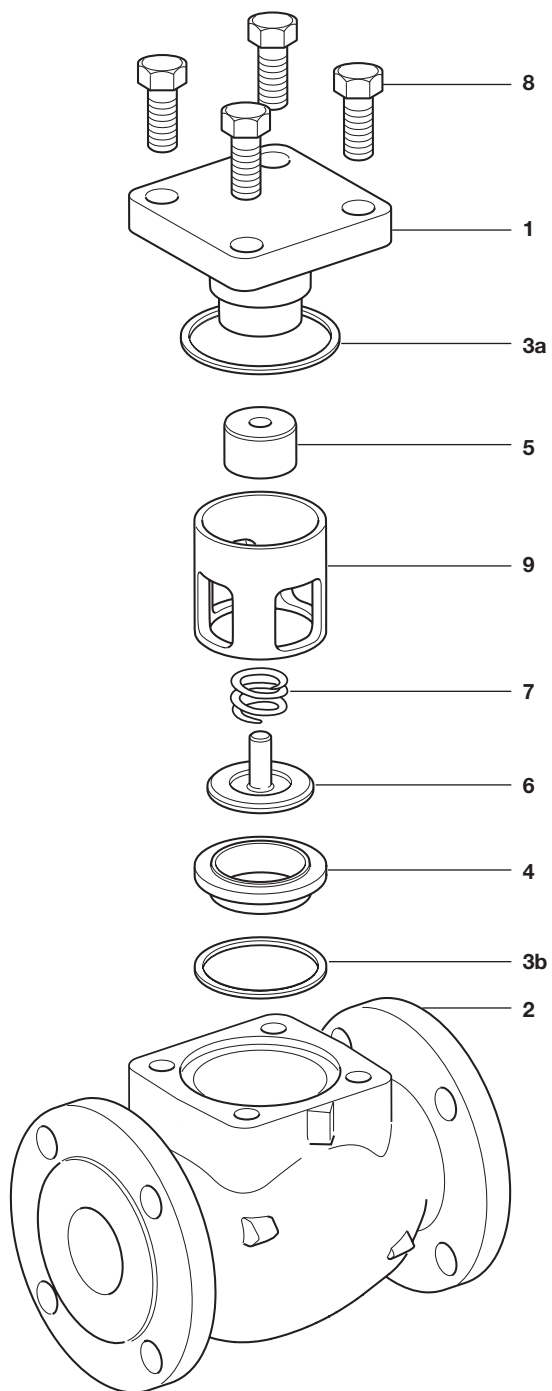

Fig. 7

