IPC6 and IPC6 ATEX

Electro-pneumatic Convertor

Installation and Maintenance Instructions



1. Safety information
2. General product information
3. Installation
4. Commissioning
5. Maintenance
6. Fault finding
7. Approvals

1. Safety information

Safe operation of these products can only be guaranteed if they are properly installed, commissioned, used and maintained by qualified personnel (see Section 1.11) in compliance with the operating instructions. General installation and safety instructions for pipeline and plant construction, as well as the proper use of tools and safety equipment must also be complied with.



WARNING: The maximum process fluid temperature must be suitable for use if the unit is to be used in any potential explosive atmosphere. For the device maintenance in a potentially explosive atmosphere, we recommend the usage of tools which do not produce and / or propagate sparks.

1.1 Explosion Proof Warnings

Please ensure the unit is being used and installed in conformity with local, regional, and national explosion proof environment.

- Refer to "7. Approvals"
- Explosion proof type of cables and gaskets should be used, when explosion gases are present at the installation site.
- Power should be turned off before removing the plug.
- There is risk of explosion due to static electricity charge. Static electricity charge may develop when cleaning the product with a dry cloth. It is imperative to avoid static electricity charge in the hazardous environment. If cleaning the surface of the product is needed, must use a damp cloth.
- Under certain extreme circumstances, the non-metallic parts incorporated in the enclosure of this equipment may generate an ignition capable level of electrostatic charge. Therefore, the equipment shall not be installed in a location where the external conditions are conducive to the build-up of electrostatic charge on such surfaces. In addition, the equipment shall only be cleaned with a damp cloth.
- The enclosures are manufactured from aluminium alloy. In rare cases, ignition sources due to impact and friction sparks could occur. This shall be considered during installation, particularly if the equipment is installed in a zone 0 location.
- When the product is used and maintained in a dusty environment, corresponding cleaning measures should be taken regularly to prevent the accumulation of dust on the surface, but compressed air must not be used for blowing.
- This equipment contains no user-replaceable parts and is not intended to be repaired by the user. Repair of the equipment is to be carried out by the manufacturer, or their approved agents, in accordance with the applicable code of practice.
- The installation, use and maintenance of the product should also comply with
GB3836.13-2013 Explosive atmospheres
Part 13: Equipment repair, overhaul and reclamation GB/T3836.15-2017 Explosive atmospheres
Part 15: Electrical installations design, selection and erection GB/T3836.16-2017 Explosive atmospheres
Part 16: Electrical installations inspection and maintenance GB50257-2014 Code for construction and acceptance of electric device for explosive atmospheres and fire hazard electrical equipment installation engineering GB15577-2018 Safety regulations for dust explosion prevention and protection.

1.2 Intended use

Referring to the Installation and Maintenance Instructions, product markings and Technical Information Sheet, check that the product is suitable for the intended use / application. These products comply with the requirements of the Directive 2014/34/EU (ATEX) for the use of equipment in potentially explosive atmospheres.

1.3 Access

Ensure safe access and if necessary a safe working platform (suitably guarded) before attempting to work on the product. Arrange suitable lifting gear if required.

1.4 Lighting

Ensure adequate lighting, particularly where detailed or intricate work is required.

1.5 Hazardous liquids or gases in the pipeline

Consider what is in the pipeline or what may have been in the pipeline at some previous time. Consider: flammable materials, substances hazardous to health, extremes of temperature.

1.6 Hazardous environment around the product

Consider: explosion risk areas, lack of oxygen (e.g. tanks, pits), dangerous gases, extremes of temperature, hot surfaces, fire hazard (e.g. during welding), excessive noise, moving machinery.

The convertor is suitable for installation in Zone 0 or Zone 1 or Zone 2 (Gas) Zone 20 or Zone 21 or Zone 22 (Dust).

1.7 The system

Consider the effect on the complete system of the work proposed. Will any proposed action (e.g. closing isolation valves, electrical isolation) put any other part of the system or any personnel at risk?

Dangers might include isolation of vents or protective devices or the rendering ineffective of controls or alarms. Ensure isolation valves are opened and closed progressively to avoid system shocks.

1.8 Pressure systems

Ensure that any pressure is isolated and safely vented to atmospheric pressure. Consider double isolation (double block and bleed) and the locking or labelling of closed valves. Do not assume that the system has depressurised even when the pressure gauge indicates zero.

1.9 Temperature

Allow time for temperature to normalise after isolation to avoid the danger of burns.

1.10 Tools and consumables

Before starting work ensure that you have suitable tools and/ or consumables available. Use only genuine Spirax Sarco replacement parts.

1.11 Protective clothing

Consider whether you and/ or others in the vicinity require any protective clothing to protect against the hazards of, for example, chemicals, high / ow temperature, radiation, noise, falling objects, and dangers to eyes and face.

1.12 Permits to work

All work must be carried out or be supervised by a suitably competent person. Installation and operating personnel should be trained in the correct use of the product according to the Installation and Maintenance Instructions.

Where a formal 'permit to work' system is in force it must be complied with. Where there is no such system, it is recommended that a responsible person should know what work is going on and, where necessary, arrange to have an assistant whose primary responsibility is safety. Post 'warning notices' if necessary.

1.13 Handling

Manual handling of large and/ or heavy products may present a risk of injury. Lifting, pushing, pulling, carrying or supporting a load by bodily force can cause injury particularly to the back. You are advised to assess the risks taking into account the task, the individual, the load and the working environment and use the appropriate handling method depending on the circumstances of the work being carried out.

1.14 Residual hazards

In normal use the external surface of the product may be hot.

1.15 Freezing

Provision must be made to protect products which are not self-draining against frost damage in environments where they may be exposed to temperatures below freezing point.

1.16 Disposal

Unless otherwise stated in the Installation and Maintenance Instructions, this product is recyclable and no ecological hazard is anticipated with its disposal providing due care is taken.

1.17 Returning products

Customers and stockists are reminded that under EC Health, Safety and Environment Law, when returning products to Spirax Sarco they must provide information on any hazards and the precautions to be taken due to contamination residues or mechanical damage which may present a health, safety or environmental risk. This information must be provided in writing including Health and Safety data sheets relating to any substances identified as hazardous or potentially hazardous.

2. General product information

2.1 Introduction

The IPC6 is a Electro-pneumatic convertor requiring an air supply between 20 and 120 psi g. It will convert a 4 -20mA signal into an air pressure signal. The IPC6 can be mounted directly onto a flat surface, or using mounting kits for panel, wall or pipe mounting.

2.2 Label Description

- Model, Indicates the model number and additional symbols.
- Explosion proof, Indicates certified explosion proof grade.
- Ingress Protection, Indicates enclosure protection grade.
- Input signal, Indicates input signal range.
- Ambient temperature, Indicates the allowable ambient temperature for explosion proof.
- Output Pressure, Indicates the output pressure range.
- Supply Pressure, Indicates the supply pressure range.
- Serial number, Indicates manufactured month and year.

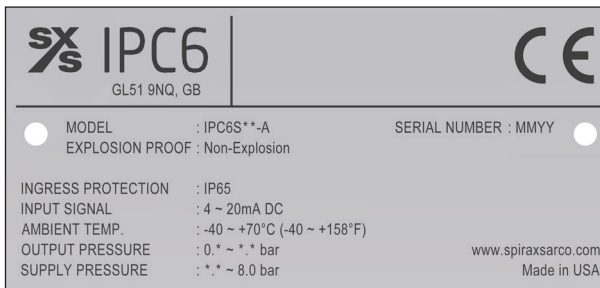

Fig. 1a Nameplate - Non-Explosion Proof

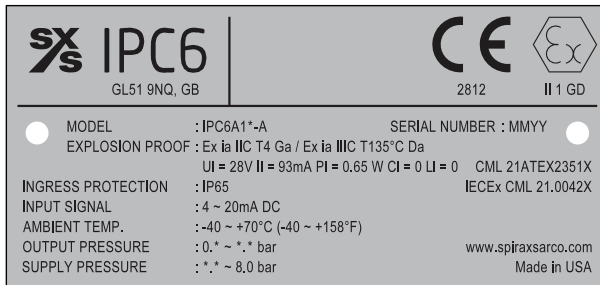

Fig. 1b Nameplate - ATEX / IECEx

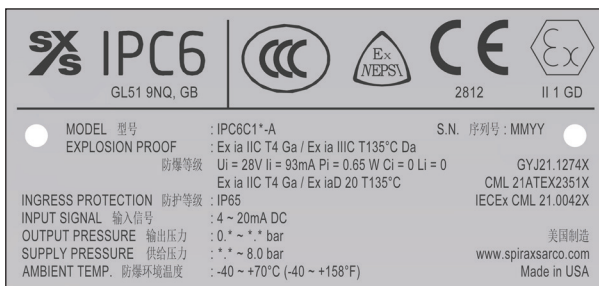

Fig. 1c Nameplate - CCC / NEPSI / ATEX / IECEx

2.3 Operating principle

The IPC6 is an electro-pneumatic device that converts a DC input signal to a pneumatic output. This device is made up of two sections, the Primary Converting Section and the Pneumatic Relay Section. The Coil and Suspension Spring, in the Primary Converting Section, is used as a Flapper. Together the Flapper and Nozzle work to control the signal pressure. The signal pressure acts on the Upper Control Diaphragm, in the Pneumatic Relay Section, which sets the output pressure. The output pressure is sensed by the Lower Control Diaphragm, in the Pneumatic Relay Section, which maintains the output pressure.

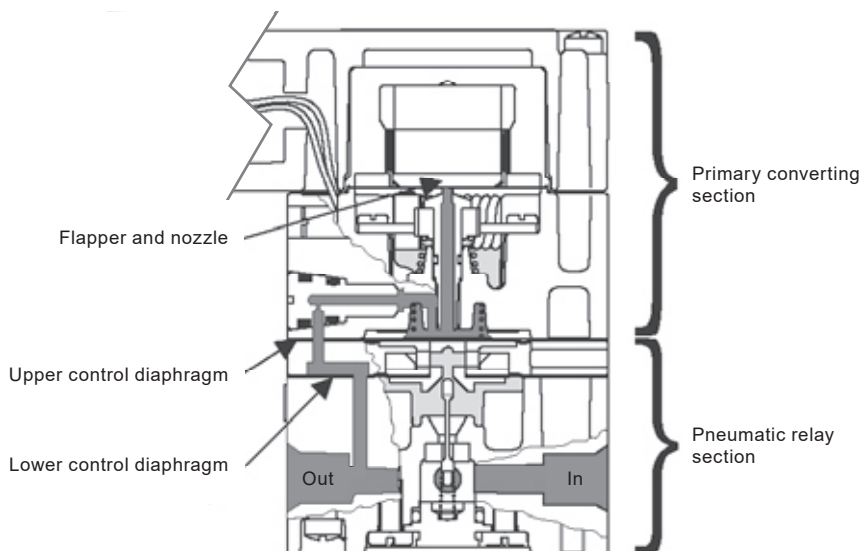
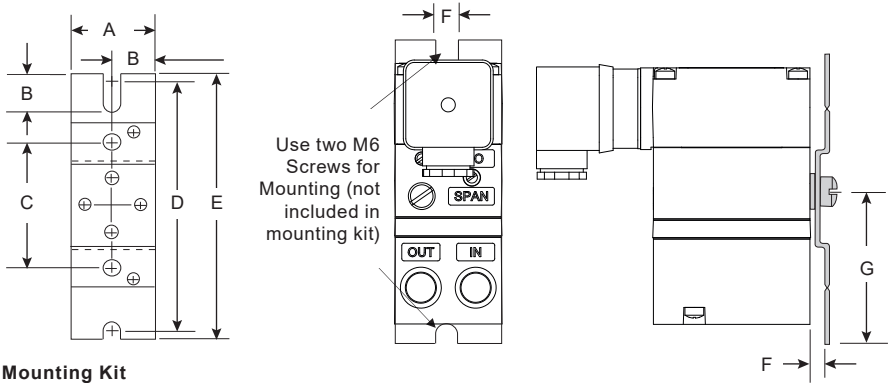

Fig. 2 IPC6

3. Installation

The IPC6 is supplied with a wall mounting kit and a DIN Rail Mounting Kit.
 Mounting Kit PMK is available when installing the unit on a 2" pipe, see Figure 5.



Mounting Kit
 Includes the following:
 Two 10-32 x 5/16" Screws
 Mounting Bracket Two 1/4" NPT Pipe Plugs
 Two 5 mm thick washers

Fig. 3 Mounting Kit (Included with unit)

Dimensions

A	B	C	D	E	F	G	H	I	J	K	L	M
38	19	57	114	123	7	62	34.5	35	32	21	15	16
(1.50)	(0.75)	(2.24)	(4.49)	(4.84)	(0.28)	(2.44)	(1.36)	(1.38)	(1.26)	(0.83)	(0.59)	(0.63)

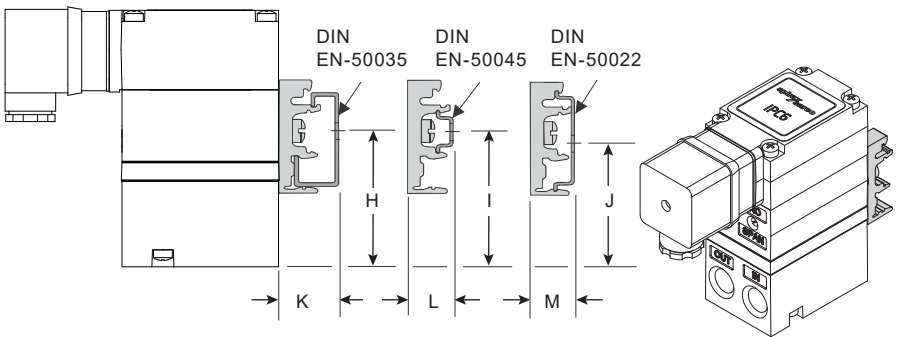
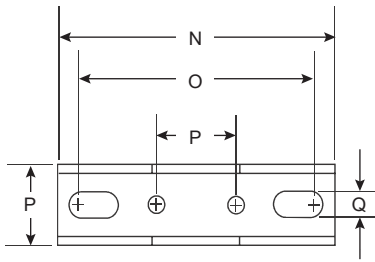

Fig. 4 DIN Rail Mounting Kit (Included with unit)

**Din Rail
 Mounting Configuration**
 shown with Model IPC6
 and DIN EN-50045



Mounting Kit PMK
 includes the following:
 Mounting Bracket 2" Pipe Clamp
 Two 10-32 x 5/16" Screws

2" Pipe Mounting Configuration shown
 with Model IPC6

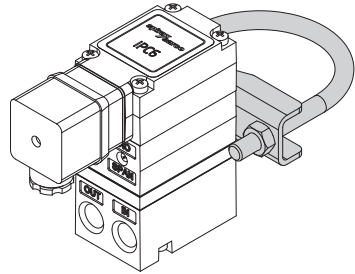

Dimensions

N	O	P	Q
89	68	25	9
(3.50)	(2.68)	(0.98)	(0.35)

Fig. 5 Mounting Kit (Sold Separately)

Pneumatic Connection

- Clean all pipelines to remove dirt and scale before installation.
- Apply a minimum amount of pipe compound to the male threads of the fitting only.
- Do not use teflon tape as a sealant.
- Start with the third thread back and work away from the end of the fitting to avoid contaminating the convertor.
- Install the convertor in the air line.
- The inlet and outlet ports are labeled on the ends of the convertor.
- Tighten connections securely.
- Avoid undersized fittings that will limit the flow through the convertor and cause pressure drop down stream.

Electric Connection

Make connections as shown in Figure 6.

Note:

Oil free air is required.

Use a filter to remove dirt and liquid in the air line ahead of the convertor.

The user is responsible for insuring that the environment in which the unit will be installed and the operating gas are compatible with the materials in the convertor.

4. Commissioning

4.1 Equipment required for calibration:

Pneumatic Supply capable of delivering up to 150 psi g.

- Current Supply capable of delivering up to 60 mA.
- Pressure gauge capable of a digital readout up to 45 psi g with an accuracy of 0.1%.
- Digital ammeter capable of a readout up to 60 mA with an accuracy of 0.02%.

4.2 Full range operation

Caution:

Over-ranging the Zero Screw can damage unit.

Forward acting mode adjustment

1. Connect the input signal to the convertor as shown in Fig. 6.

Forward Acting Calibration-Zero

2. Apply the minimum input signal and adjust the Zero screw for minimum output pressure.
Turn screw clockwise to increase pressure and counterclockwise to decrease pressure.

Forward Acting Calibration-Span

3. Apply the maximum input signal and adjust the Span screw for maximum output pressure.
Turn screw clockwise to increase pressure and counterclockwise to decrease pressure.
4. Repeat steps 2-3 until the desired output range is obtained.

Reverse Acting Mode Adjustment

5. Connect the input signal to the convertor as shown in Fig. 6.

Reverse Acting Calibration-Zero

6. Apply the minimum input signal and adjust the Zero screw for maximum output pressure.
Turn screw clockwise to increase pressure and counterclockwise to decrease pressure.

Reverse Acting Calibration-Span

7. Apply the maximum input signal and adjust the Span screw for minimum output pressure.
Turn screw clockwise to decrease pressure and counterclockwise to increase pressure.
8. Repeat steps 6-7 until the desired output range is obtained.

Split range operation

All units have the capability to be split ranged or set for any output in the range as long as the Output Span is equal to or greater than the minimum Span.

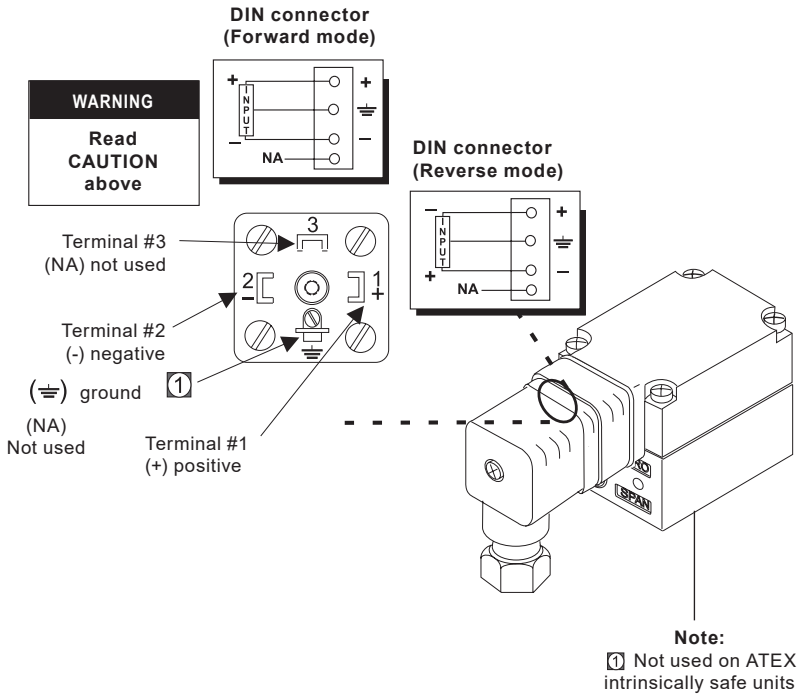

Fig. 6

5. Maintenance

5.1 Regular maintenance

1. Drain any build-up within the air supply filter set as impurities such as oil, water and dirt will cause inconsistent operation.
2. Ensure air supply is at the correct pressure.
3. Wipe the unit with a damp cloth or antistatic products.

5.2 Product return procedure

Please provide the following information with any equipment being returned:

1. Your name, Company name, address and telephone number, order number and invoice and return delivery address.
2. Description of equipment being returned.
3. Description of the fault.
4. If the equipment is being returned under warranty, please indicate:
 - i. Date of purchase
 - ii. Original order number
 - iii. Serial number

Please return all items to your local Spirax Sarco branch.

Please ensure all items are suitably packed for transit (preferably in the original cartons).

6. Fault finding

Warning:

Failure of convertor could result in output pressure increasing to supply pressure possibly causing personal injury or damage to equipment.

Problem	Solution (check)
No output	Supply pressure
	Clogged orifice
	Input signal
	Pneumatic connections
Low or improper Span adjust	Zero and span adjust
	Supply pressure low
	Output leakage
Erratic operation	DC signal
	Loose wires or connections
	Liquid in air supply
	Dirt in magnet gap

7. Approvals

ATEX

Rating : II1 GD Ex ia IIC T4 Ga/Ex ia IIIC T135°C Da

Certification No. : CML 21ATEX2351X

Ambient temperature : -40 ~ +70 °C (-40 ~ +158 °F)

Safety parameters: Ui=28V, li=93mA, Pi=0.65W, Ci=0, Li=0

IECEX

Rating : Ex ia IIC T4 Ga/EX ia IIIC T135 °C Da, NEMA4

Certification No. : IECEX CML 21.0042X

Ambient temperature : -40 ~ +70 °C (-40 ~ +158 °F)

Safety parameters: Ui=28V, li=93mA, Pi=0.65W, Ci=0, Li=0

CCC / NEPSI

Rating : Ex ia IIC T4 Ga/Ex iaD 20 T135°C

Certification No. : GYJ21.1274X

Ambient temperature : -40 ~ +70 °C (-40~+158 °F)

Safety parameters: Ui=28V, li=93mA, Pi=0.65W, Ci=0, Li=0

EU DECLARATION OF CONFORMITY

Apparatus model/Product: **Electric to Pressure Transducer (controller)
IPC6**

Name and address of the manufacturer or his authorised representative: **Spirax Sarco Ltd,**
Runnings Road
Cheltenham
GL51 9NQ
United Kingdom

This declaration of conformity is issued under the sole responsibility of the manufacturer.

The object of the declaration described above is in conformity with the relevant Union harmonisation legislation:

2014/30/EU EMC Directive
2014/34/EU ATEX Directive

References to the relevant harmonised standards used or references to the other technical specifications in relation to which conformity is declared:

EMC Directive EN 61326-1:2013

ATEX Directive EN IEC 60079-0:2018
EN 60079-11:2012

Where applicable, the notified body:

<i>Notified Body</i>	<i>number</i>	<i>Performed</i>	<i>Certificate</i>
Element Materials Technology Rotterdam B.V. Voorerf 18, 4824 GN Breda Netherlands	2812	<i>Issue of Quality Assurance Notification</i>	TRAC13QAN0002
CML B.V. Hoogoorddreef 15 1101BA Amsterdam, Netherlands	2776	<i>Issue of EC Type examination certificate</i>	CML 21ATEX2351X

Additional information:

ATEX coding:  II 1 GD Ex ia IIC T4 Ga Ex ia IIIC T135°C Da
Ta= -40°C to +70°C

On behalf of: Spirax Sarco Ltd,

(name, function): M Sadler
Steam Business Development Engineering
Product Integrity & Compliance Manager

(place and date of issue): Cheltenham
2021-06-24

GNP234-EU-C/02 issue 1 (EN)

Page 1/1

