

HP70 Series
Bimetallic Steam Trap
Installation and Maintenance Instructions

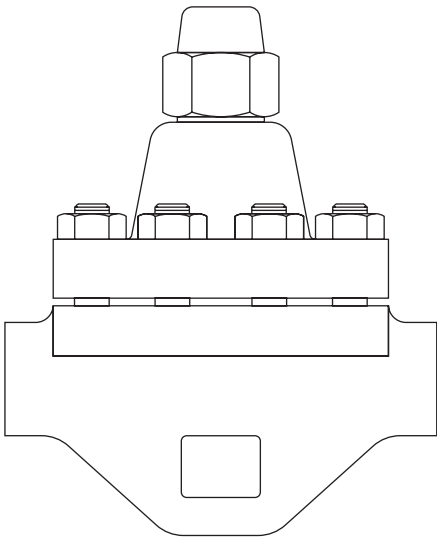

1. Safety information
2. General product information
3. Installation
4. Commissioning
5. Operation
6. Maintenance
7. Spare parts
8. Fault finding

1. Safety information

Safe operation of these products can only be guaranteed if it is properly installed, commissioned, used and maintained by qualified personnel (see Section 1.11) in compliance with the operating instructions. General installation and safety instructions for pipeline and plant construction, as well as the proper use of tools and safety equipment must also be complied with.

1.1 Intended use

Referring to the Installation and Maintenance Instructions, name-plate and Technical Information Sheet, check that the product is suitable for the intended use/application. These products comply with the requirements of the Pressure Equipment Directive (PED) and all fall within category 'SEP'.

It should be noted the product within this category are required by the Directive not to carry the  mark.

- i) This product has been specifically designed for use on steam, air or water/ condensate which are in Group 2 of the above mentioned Pressure Equipment Directive. This products' use on other fluids may be possible but, if this is contemplated, Spirax Sarco should be contacted to confirm the suitability of the product for the application being considered.
- ii) Check material suitability, pressure and temperature and their maximum and minimum values. If the maximum operating limits of the product are lower than those of the system in which it is being fitted, or if malfunction of the product could result in a dangerous overpressure or overtemperature occurrence, ensure a safety device is included in the system to prevent such over-limit situations.
- iii) Determine the correct installation situation and direction of fluid flow.
- iv) Spirax Sarco products are not intended to withstand external stresses that may be induced by any system to which they are fitted. It is the responsibility of the installer to consider these stresses and take adequate precautions to minimise them.
- v) Remove protection covers from all connections and protective film from all name-plates, where appropriate, before installation on steam or other high temperature applications.

1.2 Access

Ensure safe access and if necessary a safe working platform (suitably guarded) before attempting to work on the product. Arrange suitable lifting gear if required.

1.3 Lighting

Ensure adequate lighting, particularly where detailed or intricate work is required.

1.4 Hazardous liquids or gases in the pipeline

Consider what is in the pipeline or what may have been in the pipeline at some previous time. Consider: flammable materials, substances hazardous to health, extremes of temperature.

1.5 Hazardous environment around the product

Consider: explosion risk areas, lack of oxygen (e.g. tanks, pits), dangerous gases, extremes of temperature, hot surfaces, fire hazard (e.g. during welding), excessive noise, moving machinery.

1.6 The system

Consider the effect on the complete system of the work proposed. Will any proposed action (e.g. closing isolation valves, electrical isolation) put any other part of the system or any personnel at risk?

Dangers might include isolation of vents or protective devices or the rendering ineffective of controls or alarms. Ensure isolation valves are turned on and off in a gradual way to avoid system shocks.

1.7 Pressure systems

Ensure that any pressure is isolated and safely vented to atmospheric pressure.

Consider double isolation (double block and bleed) and the locking or labelling of closed valves. Do not assume that the system has depressurised even when the pressure gauge indicates zero.

1.8 Temperature

Allow time for temperature to normalize after isolation to avoid danger of burns.

1.9 Tools and consumables

Before starting work ensure that you have suitable tools and/or consumables available. Use only genuine Spirax Sarco replacement parts.

1.10 Protective clothing

Consider whether you and/or others in the vicinity require any protective clothing to protect against the hazards of, for example, chemicals, high/low temperature, radiation, noise, falling objects, and dangers to eyes and face.

1.11 Permits to work

All work must be carried out or be supervised by a suitably competent person.

Installation and operating personnel should be trained in the correct use of the product according to the Installation and Maintenance Instructions.

Where a formal 'permit to work' system is in force it must be complied with. Where there is no such system, it is recommended that a responsible person should know what work is going on and, where necessary, arrange to have an assistant whose primary responsibility is safety. Post 'warning notices' if necessary.

1.12 Handling

Manual handling of large and/or heavy products may present a risk of injury. Lifting, pushing, pulling, carrying or supporting a load by bodily force can cause injury particularly to the back. You are advised to assess the risks taking into account the task, the individual, the load and the working environment and use the appropriate handling method depending on the circumstances of the work being done.

recyclable and no ecological hazard is anticipated with its disposal providing due care is taken.

including Health and Safety data sheets relating to any substances identified as hazardous or potentially hazardous.

1.13 Residual hazards

In normal use the external surface of the product may be very hot. If used at the maximum permitted operating conditions the surface temperature of some products may reach temperatures in excess of 842 °F (450 °C).

Many products are not self-draining. Take due care when dismantling or removing the product from an installation (refer to 'Maintenance instructions').

1.14 Freezing

Provision must be made to protect products which are not self-draining against frost damage in environments where they may be exposed to temperatures below freezing point.

1.15 Disposal

Unless otherwise stated in the Installation and Maintenance Instructions, this product is recyclable and no ecological hazard is anticipated with its disposal providing due care is taken.

1.16 Returning products

Customers and stockists are reminded that under EC Health, Safety and Environment Law, when returning products to Spirax Sarco they must provide information on any hazards and the precautions to be taken due to contamination residues or mechanical damage which may present a health, safety or environmental risk. This information must be provided in writing including Health and Safety data sheets relating to any substances identified as hazardous or potentially hazardous.

2. General product information

2.1 General description

The Spirax Sarco HP70 bimetallic steam trap is made of forged steel, and designed for draining high pressure, high temperature steam lines and processes.

This steam trap, which is specially designed for HP steam, has a reinforced stainless steel insert within the body and can be repaired online.

Normally open in the event of failure, it has a retaining valve, a built-in strainer screen and an external device for adjusting the discharge temperature of the condensate.

Standards

This product fully complies with the requirements of the Pressure Equipment Directive (PED).

Certification

This product is available with certification to EN 10204 3.1.

Note: All certification/inspection requirements must be stated at the time of order placement.

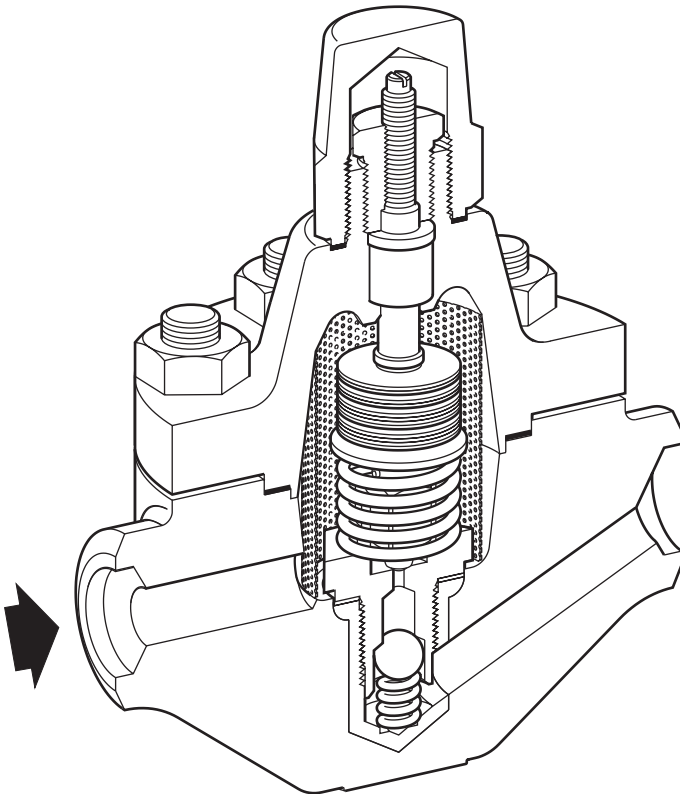
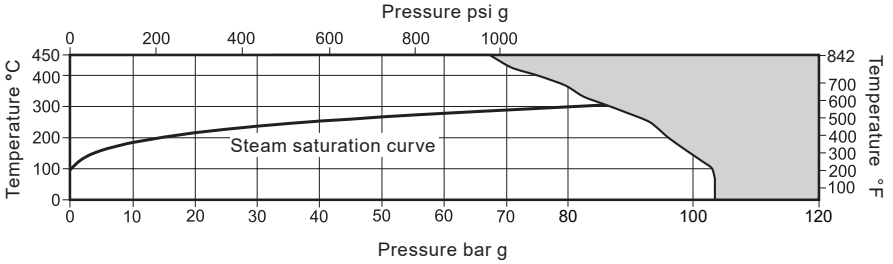

Fig. 1 HP70 shown

2.2 Sizes and pipe connections

½", ¾" and 1" Socket weld to ANSI B 16.11 or Butt weld to ANSI B 16.25.

2.3 Pressure/temperature limits



The product **must not** be used in this region.

Body design condition	ASTM A182 F11	
PMA Maximum allowable pressure	1500 psi g @ 122 °F	(103.4 bar g @ 50 °C)
TMA Maximum allowable temperature	842 °F @ 982 psi g	(450 °C @ 67.7 bar g)
PMO Maximum operating pressure	1015 psi g @ 797 °F	(70 bar g @ 425 °C)
TMO Maximum operating temperature	797 °F @ 1015 psi g	(425 °C @ 70 bar g)
Minimum allowable temperature	6.8 °F	(-14 °C)
Minimum inlet pressure for satisfactory operation is:	290 psi g	(20 bar g)
Minimum operating temperature	32 °F	(0 °C)
ΔPMX The backpressure for correct operation must not exceed 90% of the upstream pressure		
Designed for a maximum cold hydraulic test pressure of:	2263 psi g	(156 bar g)

3. Installation

Note: Before actioning any installation observe the 'Safety information' in Section 1.

Referring to the Installation and Maintenance Instructions, name-plate and Technical Information Sheet, check that the product is suitable for the intended installation:

- 3.1** Check materials, pressure and temperature and their maximum values. If the maximum operating limit of the product is lower than that of the system in which it is being fitted, ensure that a safety device is included in the system to prevent overpressurisation.
- 3.2** Determine the correct installation situation and the correct direction of fluid flow.
- 3.3** Remove protective covers from all connections and protective film from all name-plates, where appropriate, before installation on steam or other high temperature applications.
- 3.4** Install the steam trapping station downstream of the equipment to be drained, ensuring that it is easily accessible for inspection and maintenance.
- 3.5** The steam trap may be installed in any position, except where discharge is flowing vertically upwards. Optimum performance will be achieved if installed horizontally.
- 3.6** Before installing the trap, ensure all connecting pipework is clean and free of debris.
- 3.7** Mount the steam trap with the arrow on the body pointing in the direction of the flow of the liquid.
- 3.8** The steam trap can be welded onto the pipework without removing the internal components. If there is any possibility of the line freezing, the axis of the bonnets should be installed horizontally. For socket welded traps, observe qualified welding procedures. It is not necessary to remove the trap internals when welding, but avoid excessive heat.
- 3.9** The steam trap is factory set at 113 °F below steam saturation temperature.

Note: If the trap is to discharge to atmosphere ensure it is to a safe place, the discharging fluid may be at a temperature of 212 °F (100°C).

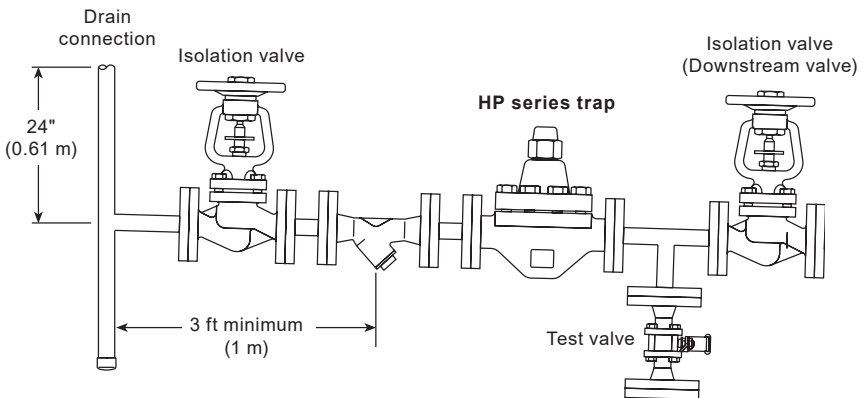

Fig. 2 Recommended installation - Note: pipework to fall in the direction of flow.

4. Commissioning

After installation or maintenance ensure that the system is fully functioning. Carry out tests on any alarms or protective devices.

Note: During commissioning the valve may need resetting to take account of any backpressure in the return line.

5. Operation

The Spirax Sarco HP70 is a bimetallic steam trap.

This trap operates on the basis of two opposing forces acting on the valve - an opening force created by the valve opening spring, and a closing force resulting from the condensate temperature acting on the bimetallic elements.

It operates with no loss of steam and automatically and quickly drains air, non-condensable gases and large quantities of cold water on start-up.

6. Maintenance

Important note:

Before actioning any maintenance program observe the 'Safety information' in Section 1.

Safety note:

This trap is installed in high pressure steam lines. Personnel doing the adjustment work should wear heavy gloves, long sleeve shirt, and other safety equipment designed to protect the wearer (goggles, face shield, etc.) in the event of a leak.

The equipment needed to proceed with any maintenance program is listed in Table 1.

The HP70 has an external adjustment screw, which permits the flushing of the trap seat and the setting of the discharge temperature of the condensate in the inlet line allowing optimum performance to be achieved.

Maintenance note:

Maintenance can be completed with the trap in the pipeline, once the safety procedures have been observed. It is recommended that new gaskets and spares are used whenever maintenance is undertaken. Ensure that the correct tools and necessary protective equipment are used at all times. When maintenance is complete open isolation valves slowly and check for leaks.

6.1 Trap seat flushing during operation

This maintenance operation should be performed once every six months.

To clean the steam trap during operation, it is advisable to close the steam inlet valve before turning the adjustment screw, and proceed as follows: (in a closed return system, close the discharge line and open the test valve):

- Remove the blind nut (11) and loosen the locking gland nut (6) by turning clockwise.
Note: the gland nut and adjustment screw have left hand threads.
- Using a screwdriver, loosen the adjustment screw a few turns, clockwise. This completely disengages the valve from the valve seat (12).
- Open the steam inlet valve slightly. This causes a strong purging action, which removes any impurities that may have been deposited in the steam trap.
- Turn the adjustment screw anticlockwise until the valve comes into contact with the valve seat (12). Turn through a further ¼ turn anticlockwise.
- Retighten the locking gland nut (6) to the recommended torque (see Table 1) in order to lock and reduce leakage past the adjustment screw.
- Replace the blind nut (11) and gasket (10) and tighten to the recommended torque as specified in Table 1.
- Shut the test valve and open the discharge line valve and check for leaks.
- Allow the trap to operate for several minutes and review the operation to ensure it is correct.

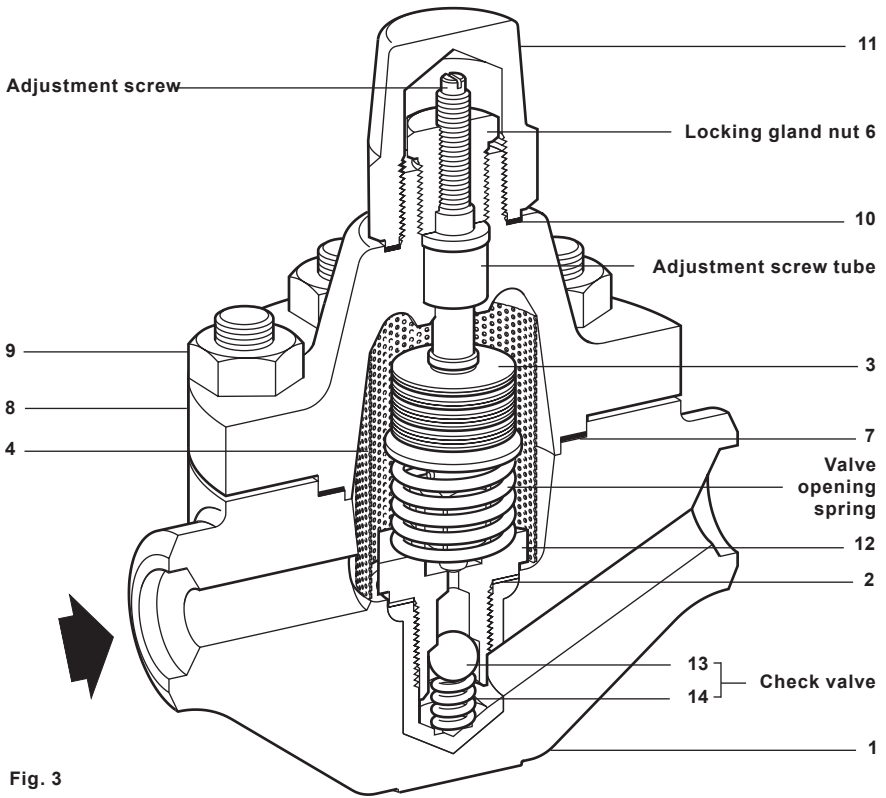



Fig. 3

Table 1 Spanners to be used and recommended tightening torques

Item	Part	 or 	N m (lbf ft)
3	Bimetallic element - pipe spanner	36 A/F	120 (88)
6	Locking gland nut on adjustment screw	21 A/F	38 (28)
9	Cover nut	24 A/F	105 (77.5)
11	Blind nut	41 A/F	80 (59)

6.2 Trap discharge temperature adjustment

This procedure is the same as that given in Section 6.1. However, prior to re-tightening the locking gland nut, the discharge temperature may be adjusted as follows:

- To reduce by 50 °F (10°C) (more subcooling), turn the screw anticlockwise ¼ turn.
- To increase by 50 °F (10°C) (less subcooling), turn the screw clockwise ¼ turn.
- Allow trap operation and condensate temperature to stabilise between adjustments. Continue adjusting until satisfactory operation is obtained.

6.3 Trap checking

In a closed return system, a test tee (see Figure 2) and valve must be used to observe trap operation. The trap should modulate the condensate discharge depending on inlet temperature and pressure.

6.4 Disassembly and service

1. Shut the trap inlet and discharge valves, vent the pressure and allow the trap to cool sufficiently to prevent possible injury from hot surfaces.
2. Remove the blind nut (11).
3. Remove the six cover nuts (9) and the cover (8).
4. Remove the strainer screen (4) and clean or replace.
5. **Note:** The valve and bimetallic element assembly (3) is assembled loosely. Carefully lift these as one piece from the body (1). Take the necessary precautions to ensure that the bimetal element arrangement is not disturbed. Inspect the valve plug for wear.
6. Remove the valve opening spring.
7. Remove the valve seat (12) with a 36 mm A/F (1 $\frac{7}{16}$ ") pipe wrench. Inspect the valve seating surface and the check valve seat for wear.
8. Remove the check valve ball (13) and check valve spring and inspect for wear.
9. Clean all gasket surfaces and remove dirt/scale from the trap internals with a wire brush or equivalent. Be careful not to damage the sealing surfaces.
10. Blow out the trap inlet piping and clean the upstream strainer if applicable.
11. The bimetallic assembly kit (see Section 7, Spare parts) consists of the bimetallic element (3), valve seat gasket (2), cover gasket (7), blind nut gasket (10), strainer screen (4), valve seat (12), check valve ball (13) and check valve spring (14).

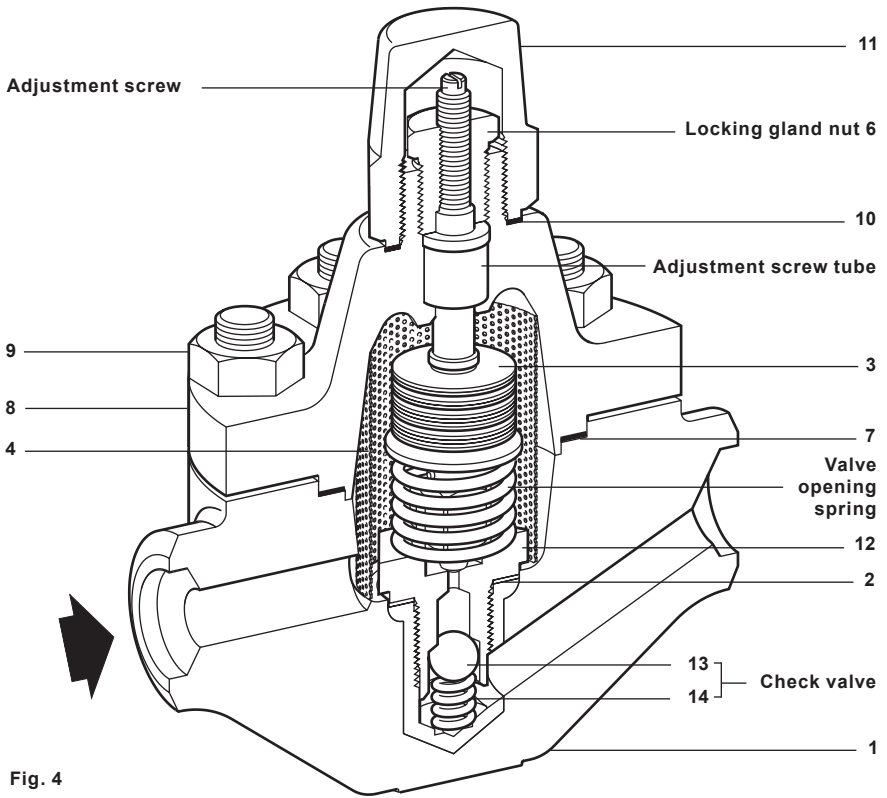

HP70 Series Bimetallic Steam Trap

6.5 Reassembly: Refer to Figure 5.

1. Place the check valve spring and ball (13 and 14) into the body (1) and position them properly.
2. Use a high temperature thread lubricant on the valve seat (12), adjustment screw threads and gasket seating surfaces.
Put the valve seat gasket (2) in place and thread the valve seat (12) into the body (1).
Tighten to the recommended torque as specified, in Table 1.
3. Install the valve opening spring.
4. Install the valve and bimetallic element assembly (3).
5. Slip the strainer screen (4) over the bimetallic element assembly with the rounded end uppermost.
6. Install the cover gasket (7).
7. Install the cover (8).
Note: Ensure that the shaft of the bimetallic element assembly (3) fits into the adjustment screw tube as the cover is put into position.
8. Install the cover nuts (9) using the high temperature thread lubricant and tighten to the recommended torque (see Table 1).
9. To adjust for cold conditions (to be done on a trap without inlet or outlet pressure):
 - Turn the adjustment screw anticlockwise to bring the valve in contact with the valve seat (12 - close position) **Do not tighten.**
 - Again using the adjustment screw, open' the valve (off the valve seat 12) by the number of clockwise turns specified in Table 2 for the appropriate size trap. This method approximates factory settings.
10. Tighten the locking gland nut (6) to the recommended torque (see Table 1) in order to lock and reduce leakage past the adjustment screw.

Table 2

Setting (full turns clockwise)	4¼
---------------------------------------	----

11. Install the blind nut and gasket (10 and 11) and torque as specified in Table 1.

7. Spare parts

The spare parts available are detailed in the table below. No other parts are supplied as spares.

Available spares	Bimetallic assembly kit	2, 3, 4, 7, 10, 12
	Check valve assembly	13, 14
	Strainer screen	4
	Cover gasket set (packet of 3)	7
	Gasket set	2, 7, 10

How to order spares

Always order spares by using the description in the column headed 'Available spares' and state the size and model of the bimetallic steam trap.

Example: 1 - Bimetallic assembly kit for a Spirax Sarco ½" HP70 bimetallic steam trap.

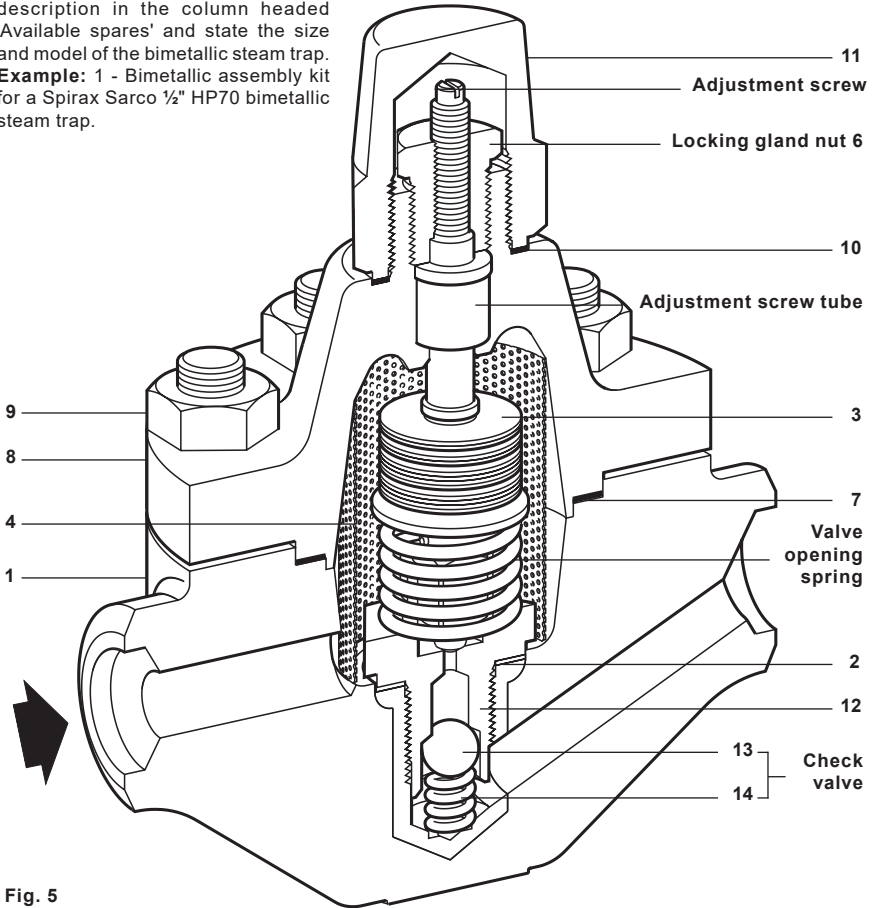

Fig. 5

HP70 Series Bimetallic Steam Trap

spirax
sarco

8. Fault finding

Trap fails to pass condensate	1.	Make sure upstream and downstream valves are open.
	2.	Check external strainers for clogging; blowdown or dismantle and clean.
	3.	Valve port clogged with dirt. Follow 'Trap seat flushing' procedure (See Section 6.1).
	4.	Bimetallic element improperly adjusted. Adjust as described under 'Trap discharge temperature adjustment' (See Section 6.2).
	5.	Dismantle and inspect internals. See 'Disassembly and service' (See Section 6.4).

Trap blows live steam	1.	Dirt on seating surface. Flush as described in 'Trap seat flushing' procedure (See Section 6.1).
	2.	Bimetallic element improperly adjusted. Adjust as described under 'Trap discharge temperature adjustment' (See Section 6.2).
	3.	Worn valve seat. Dismantle, inspect and replace if necessary. Note: The seat and bimetallic element must be replaced as a matched pair.
	4.	Backpressure too high. Downstream system must be corrected.
