

Steel Float and Thermostatic Steam Trap

3" (DN80) and 4" (DN100) FT450

Installation and Maintenance Instructions

1. Description and operation

The Spirax Sarco 3" (DN80) and 4" (DN100) FT450 is a high capacity Float & Thermostatic steam trap. The float adjusts the position of the double seated main valve so that condensate is discharged continuously at the same rate as it enters the trap. Air which is present at start up, or which collects in the trap during operation, is discharged through the integral bimetal air vent into a standpipe which is connected to the main valve mechanism housing downstream of the main valve.

The FT450 may be used on superheated steam systems within the pressure shell design conditions. It will operate against any back pressure lower than the inlet pressure. (The differential pressure - inlet pressure minus outlet pressure - determines the trap's capacity.)

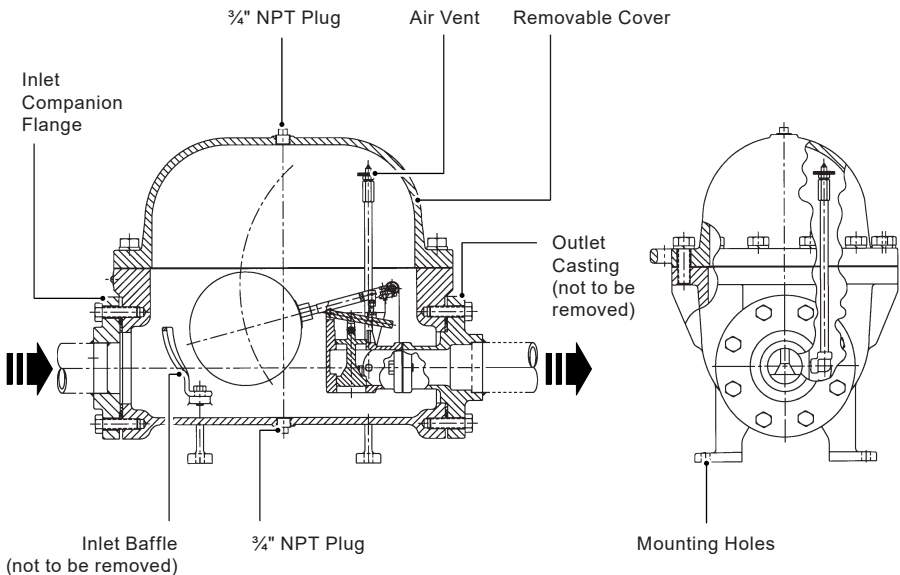

Dimensions (nominal)

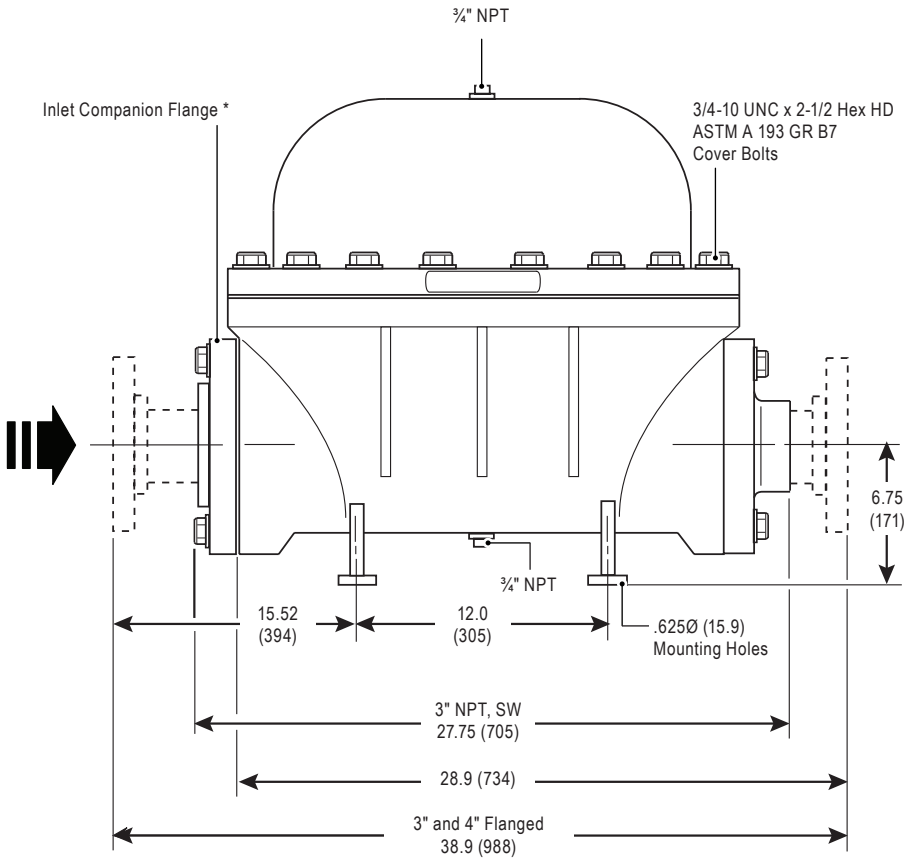

* The inlet connection on NPT and SW traps is a standard 4" (DN100) ANSI 300 RF Flange bolted to the trap body. The flange bore is 3" (DN80), NPT or SW to match the outlet connection of the trap.

Weight

485 lb. (220 kg)

Steel Float and Thermostatic Steam Trap 3" (DN80) and 4" (DN100) FT450

Dimensions (nominal) (continued)

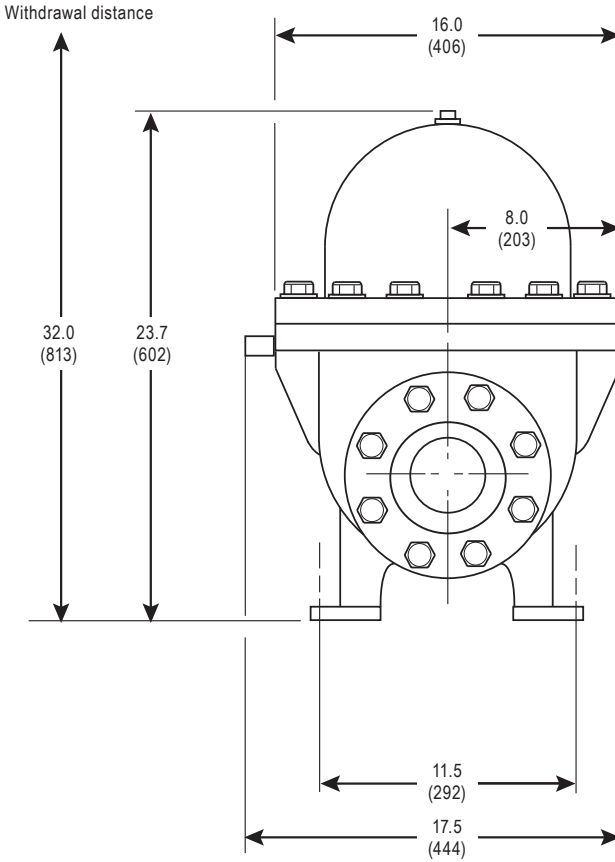

Limiting Operating Conditions FT450

Standard Configuration

Maximum Operating Pressure (PMO)	450 psi g (31 bar g)
Maximum Operating Temperature	650 °F at 450 psi g (343 °C at 31 bar g) 750 °F (400 °C) at operating pressures below 375 psi g (26 bar g)
Cold Hydraulic Test Pressure	SW and NPT - (W) 585 psi g (40.3 bar g) ANSI 150 - (W) 285 psi g (19.6 bar g) ANSI 300 - (W) 585 psi g (40.3 bar g)

Steel Float and Thermostatic Steam Trap 3" (DN80) and 4" (DN100) FT450

2. Installation

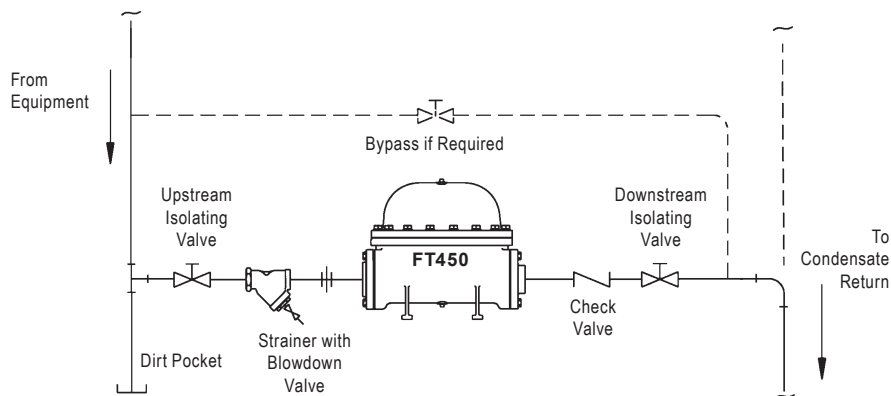

Before installing the trap, the inlet piping should be carefully blown down to remove any existing pipe debris.

Caution: Before installation, inspection or maintenance, the trap must be completely isolated from both supply and return line pressure.

The trap must be supported firmly in a horizontal position. The four feet are drilled $\frac{5}{8}$ " (15.9 mm) to accept $\frac{1}{2}$ " (12.7 mm) mounting bolts. The total weight of the trap partially filled with condensate is approximately 550 lb (250 kg). Observe the "in" and "out" markings on the body.

The trap should be positioned with the inlet no higher than, or preferably below, the equipment drain point. If possible, a drop leg and dirt pocket should be provided ahead of the trap. The horizontal distance between the equipment drain point and the trap should be no longer than necessary.

A pipeline strainer should be installed ahead of the trap, and full-flow isolating valves should be located to permit servicing. A check valve after the trap is recommended to prevent backflow.

Access above the trap must be provided for servicing. The cover weighs approximately 150 lb (68 kg), and its withdrawal distance is 32" (813 mm) from the bottom of the mounting feet.

Bypass piping is not recommended because of the possibility of misuse. If a bypass is installed, it should be at least one size smaller than the trap line size, and the bypass valve must be capable of tight shut off.

NPT and SW traps are shipped with a companion flange bolted to the inlet. This flange can be welded (or threaded) to the inlet piping.

The trap is supplied with a flanged, NPT or SW outlet connection as required. **The bolted outlet casting is not a flange, and must not be removed.**

Because condensate cannot drain completely from the body, a trap installed outdoors can freeze up if it is not in continuous operation. If there is any possibility of an interruption in the steam supply, provision should be made for draining or tracing the trap body.

When placing the trap in service, no priming is necessary. The inlet isolating valve must be opened slowly to prevent damage to the trap and piping system. It is recommended that the equipment, piping and trap be slowly warmed to operating conditions.

3. Maintenance and Repair

This trap can be serviced without disturbing the piping connections.

Caution: The trap must be isolated from both supply and return line pressure before any servicing or disassembly. Pressure which may be present in the trap after the isolating valves are closed must be relieved before the trap is opened. This can be accomplished by opening the blowdown valve on the strainer ahead of the trap and waiting until the trap has cooled. Do not attempt to remove the bolted outlet casting.

Remove and save the cover bolts and lockwashers. Lift the cover from the body, being careful not to damage the air vent standpipe, which extends approximately 7-1/2" (190 mm) above the bodycover flange surface.

Remove the bottom plug to drain the condensate remaining in the body.

Using a suitable solvent, remove all dirt and incrustation from the mechanism, body and cover.

Inspect the body and cover for condensate corrosion.

The main valve mechanism assembly is secured to the body by two cap screws. Remove the mechanism and gasket, and inspect the valve linkage and pins for signs of wear or damage.

Ensure that the pins are properly secured by the retaining washers. Inspect the valve heads and seats for damage, wear or wiredrawing. If any of the valve mechanism parts are worn or damaged, it is recommended that the entire assembly be replaced.

Inspect the float for damage, and replace if necessary. A collapsed float is evidence of extremely severe and dangerous waterhammer conditions which must be rectified before the trap is returned to service. Ensure that all traces of the old mechanism gasket are removed and that the gasket seating surfaces are clean and undamaged. Install the new or cleaned mechanism assembly, using a new gasket and a little jointing paste. Tighten the mechanism cap screws to a torque of 50-55 ft•lb (68-75 Nm).

The bimetal air vent assembly is factory-calibrated, and is not repairable. Failure to the air vent is very unlikely, but if a malfunction is suspected, the complete assembly should be replaced. The new air vent and gasket should be screwed into the adapter coupling and tightened to a torque of 27-31 ft lb (37-42 Nm).

All traces of the old gasket must be removed from the body and cover, and the gasket seating surfaces must be clean and undamaged. Fit a new gasket, applying a thin coating of jointing paste. To assist in locating the gasket and cover, bolts at the four corners may be temporarily threaded from the underside of the body flange. Install and tighten the cover bolts (with lockwashers) to a torque of 250-275 ft lb (339-373 Nm).

The strainer ahead of the trap must be serviced as required to ensure the screen is unobstructed.

The trap may be returned to service by slowly opening the isolating valves (the downstream valve should be opened first).

4. Troubleshooting

Like any other double-seated valve, the FT450 main valve may leak very slightly in the closed position. In the extremely unlikely event that the condensate load drops below the residual leakage rate (approximately 0.4% of full load), the valve may pass a very small amount of live steam. This will happen only in very unusual circumstances.

Because condensate is discharged close to steam temperature, a portion of it will re-evaporate (or "flash"). The discharge will therefore be a high-velocity mixture of liquid condensate and flash steam.

This should not be mistaken for live steam loss.

5. Spare parts

	Stock No.	Part No.
Valve Mechanism Kit	66365	D, E, F
Gasket Kit (pkt of 3 each)	66796	B, F
Air Vent Kit (Optional)	66642	H, K
Float Kit	66798	P
Air Vent Kit Standard	71512	N, J, M, H, L, K

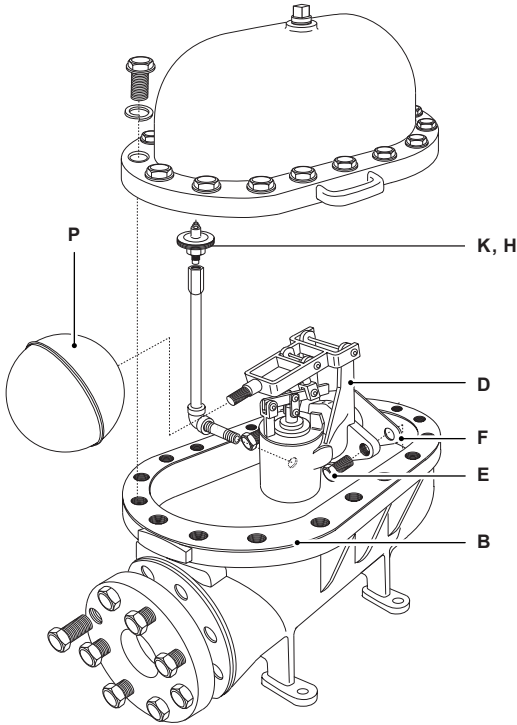

Standard air vent assembly

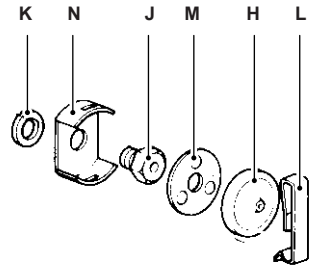

Optional bimetal air vent assembly

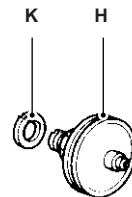

Steel Float and Thermostatic Steam Trap 3" (DN80) and 4" (DN100) FT450

For additional technical information, contact Spirax Sarco Applications
Engineering Department

Toll Free 1-800-883-4411

SPIRAX SARCO, INC.
1150 NORTHPOINT BLVD
BLYTHEWOOD, SC 29016
Phone 803-714-2000
Fax 803-714-2222
spiraxsarco.com/global/us

Steel Float and Thermostatic Steam Trap 3" (DN80) and 4" (DN100) FT450