

# Float Operated Liquid Drain Traps Types FA, FAI, FAB, CA

## Safety Information

Safe operation of these products can only be guaranteed if they are properly installed, commissioned, used and maintained by qualified personnel (see Section 1.11) in compliance with the operating instructions. General installation and safety instructions for pipeline and plant construction, as well as the proper use of tools and safety equipment must also be complied with.

### 1.1 Intended use

Referring to the Installation and Maintenance Instructions, name-plate and Technical Information Sheet, check that the product is suitable for the intended use/application.

- i) The products have been specifically designed for use on steam, air or water/condensate. The products' use on other fluids may be possible but, if this is contemplated, Spirax Sarco should be contacted to confirm the suitability of the product for the application being considered.
- ii) Check material suitability, pressure and temperature and their maximum and minimum values. If the maximum operating limits of the product are lower than those of the system in which it is being fitted, or if malfunction of the product could result in a dangerous overpressure or overtemperature occurrence, ensure a safety device is included in the system to prevent such over-limit situations.
- iii) Determine the correct installation situation and direction of fluid flow.
- iv) Spirax Sarco products are not intended to withstand external stresses that may be induced by any system to which they are fitted. It is the responsibility of the installer to consider these stresses and take adequate precautions to minimise them.
- v) Remove protection covers from all connections and protective film from all name-plates, where appropriate, before installation on steam or other high temperature applications.

### 1.2 Access

Ensure safe access and if necessary a safe working platform (suitably guarded) before attempting to work on the product. Arrange suitable lifting gear if required.

### 1.3 Lighting

Ensure adequate lighting, particularly where detailed or intricate work is required.

### 1.4 Hazardous liquids or gases in the pipeline

Consider what is in the pipeline or what may have been in the pipeline at some previous time. Consider: flammable materials, substances hazardous to health, extremes of temperature.

### 1.5 Hazardous environment around the product

Consider: explosion risk areas, lack of oxygen (e.g. tanks, pits), dangerous gases, extremes of temperature, hot surfaces, fire hazard (e.g. during welding), excessive noise, moving machinery.

### 1.6 The system

Consider the effect on the complete system of the work proposed. Will any proposed action (e.g. closing isolation valves, electrical isolation) put any other part of the system or any personnel at risk?

Dangers might include isolation of vents or protective devices or the rendering ineffective of controls or alarms. Ensure isolation valves are turned on and off in a gradual way to avoid system shocks.

### 1.7 Pressure systems

Ensure that any pressure is isolated and safely vented to atmospheric pressure. Consider double isolation (double block and bleed) and the locking or labelling of closed valves. Do not assume that the system has depressurised even when the pressure gauge indicates zero.

### 1.8 Temperature

Allow time for temperature to normalise after isolation to avoid danger of burns.

### 1.9 Tools and consumables

Before starting work ensure that you have suitable tools and/or consumables available. Use only genuine Spirax Sarco replacement parts.

### 1.10 Protective clothing

Consider whether you and/or others in the vicinity require any protective clothing to protect against the hazards of, for example, chemicals, high/low temperature, radiation, noise, falling objects, and dangers to eyes and face.

### 1.11 Permits to work

All work must be carried out or be supervised by a suitably competent person. Installation and operating personnel should be trained in the correct use of the product according to the Installation and Maintenance Instructions.

Where a formal 'permit to work' system is in force it must be complied with. Where there is no such system, it is recommended that a responsible person should know what work is going on and, where necessary, arrange to have an assistant whose primary responsibility is safety.

Post 'warning notices' if necessary.

### 1.12 Handling

Manual handling of large and/or heavy products may present a risk of injury. Lifting, pushing, pulling, carrying or supporting a load by bodily force can cause injury particularly to the back. You are advised to assess the risks taking into account the task, the individual, the load and the working environment and use the appropriate handling method depending on the circumstances of the work being done.

### 1.13 Residual hazards

In normal use the external surface of the product may be very hot. If used at the maximum permitted operating conditions the surface temperature of some products may reach temperatures in excess of 300°C (572°F).

Many products are not self-draining. Take due care when dismantling or removing the product from an installation (refer to 'Maintenance instructions').

### 1.14 Freezing

Provision must be made to protect products which are not self-draining against frost damage in environments where they may be exposed to temperatures below freezing point.

### 1.15 Disposal

Unless otherwise stated in the Installation and Maintenance Instructions, this product is recyclable and no ecological hazard is anticipated with its disposal providing due care is taken.

### 1.16 Returning products

Customers and stockists are reminded that under EC Health, Safety and Environment Law, when returning products to Spirax Sarco they must provide information on any hazards and the precautions to be taken due to contamination residues or mechanical damage which may present a health, safety or environmental risk. This information must be provided in writing including Health and Safety data sheets relating to any substances identified as hazardous or potentially hazardous.

### 1.17 Working safely with cast iron products on steam

Cast iron products are commonly found on steam and condensate systems. If installed correctly using good steam engineering practices, it is perfectly safe. However, because of its mechanical properties, it is less forgiving compared to other materials such as SG iron or carbon steel. The following are the good engineering practices required to prevent waterhammer and ensure safe working conditions on a steam system.

### Safe Handling

Cast Iron is a brittle material. If the product is dropped during installation and there is any risk of damage the product should not be used unless it is fully inspected and pressure tested by the manufacturer.

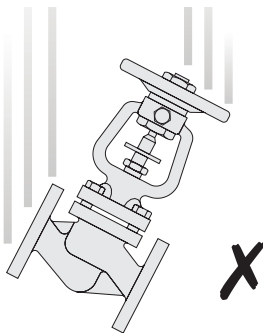

### Steam Mains - Do's and Don't's:

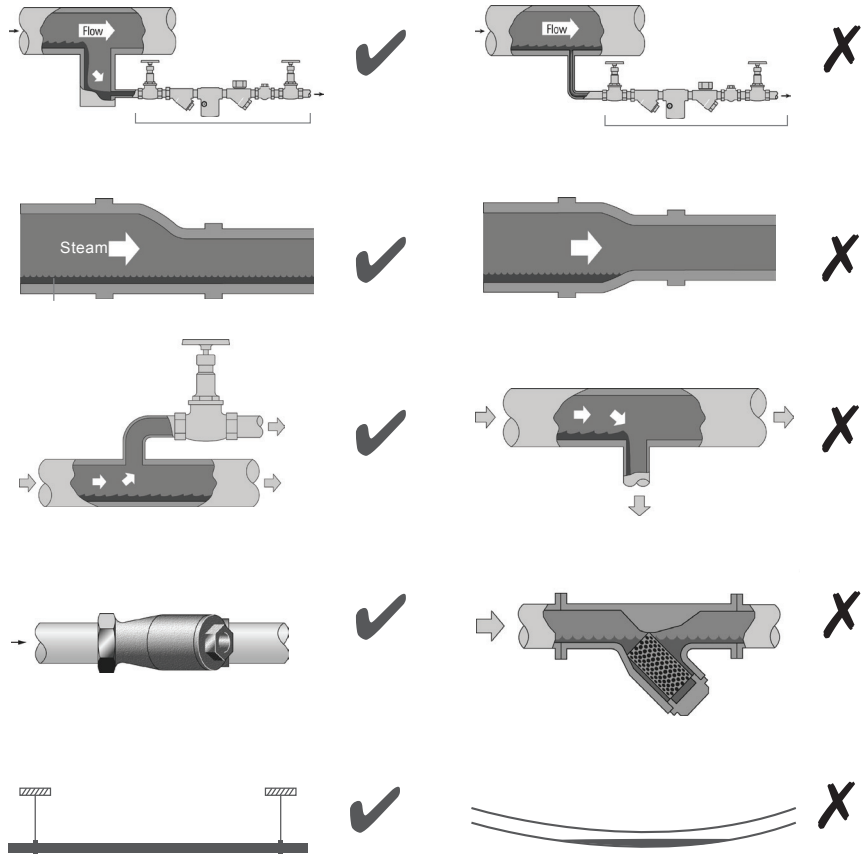

### Prevention of tensile stressing

Pipe misalignment:

Installing products or re-assembling after maintenance:



Do not over tighten.  
Use correct torque figures.

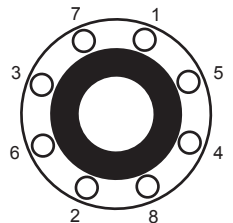
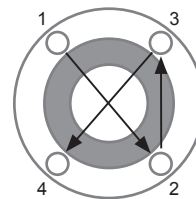

Flange bolts should be gradually tightened across diameters to ensure even load and alignment.

### Prevention of water hammer

Steam trapping on steam mains:

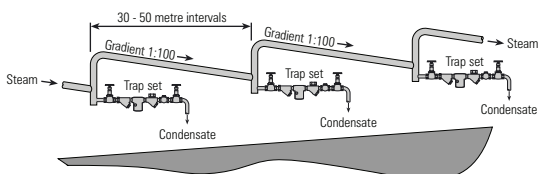

## Thermal expansion:

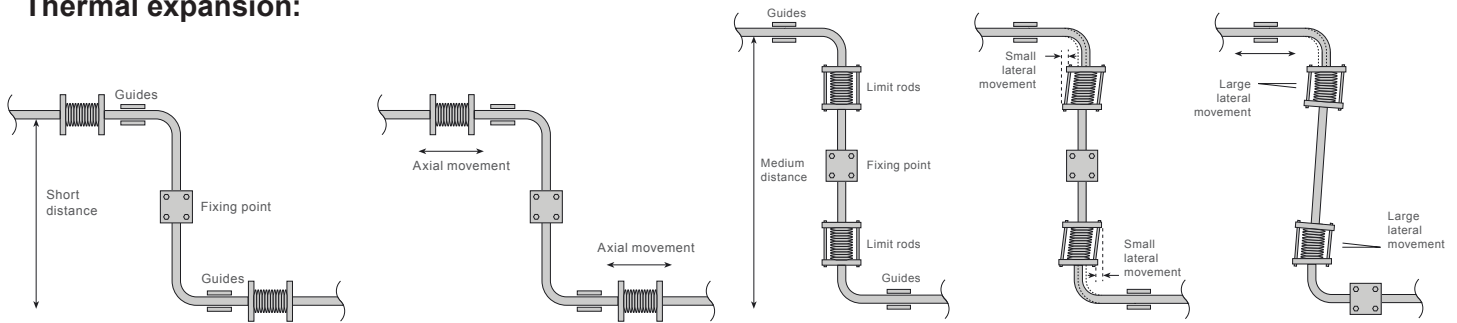

## Description and Operation

Spirax Sarco Float Operated Liquid Drain Traps have a spherical stainless steel float which continuously adjusts the valve opening so that liquid is discharged at same rate as it enters the trap. The liquid level in the Drain Trap body is always above the valve seat, sealing the valve from gas leakage. To prevent gas binding and allow liquid to flow freely into the trap, a pressure balancing pipe must be connected between the trap and the space to be drained. An NPT tapping is provided for this purpose on the top of the trap body.

## Limiting Conditions

The drain trap nameplate states the maximum working pressure (PMO) of the trap when used to drain liquids with a specific gravity of 1.0 (e.g. cold water). For lighter liquids (S.G. less than 1.0), the PMO will be lower (see TIS 7.318). If the system pressure is greater than the PMO of the trap, the excess pressure will prevent the valve from opening.

### Note:

The drain trap must never be used at pressures and temperatures greater than the maximum allowable conditions (PMA and TMA) shown on the nameplate.

Spirax Sarco Liquid Drain Traps may be subjected to a cold hydrostatic test pressure of the 1-1/2 times the nameplate PMA. If the test pressure is greater than 600 psig, the float must be removed during the test.

The following installation and maintenance instructions apply to drain traps handling non-hazardous water-like fluids. Some liquid drain trap applications, particularly those involving hazardous or unusual fluids, may be subject to regulation or may otherwise require special precautions or procedures. Float drain traps are not bubble type devices and should not be used with volatile liquids or gases without proper precautions. The trap must drain into a properly designed containment system or flare line where excess gases can be burned off safely. Drain traps on volatile liquids or gases shall never drain to open atmosphere.

## Installation

1. The drain trap nameplate should be checked to ensure that the model and pressure/temperature rating are correct.
2. The trap must be installed below the drainage point of the equipment or pipeline so that the liquid can flow by gravity into the trap.
3. Before installing the trap, the inlet piping should be carefully blown down to remove any existing pipe debris. If possible, a drop leg and dirt pocket should be provided ahead of the trap.
4. The drain trap must be installed in a vertical position so that the orientation arrow on the trap body or on the nameplate points straight down. The flow direction markings on the body or cover must be observed.
5. A pressure-balancing pipe must be installed with a continuous rise between the tapping on the top of the trap body and the space to be drained. If a separator or pipeline is being drained, the balance pipe connection must be downstream of the drainage point. For process equipment, the balance pipe connection must be above the maximum liquid level.
6. Full-port isolating valves should be installed so as to permit servicing. The balance pipe union must be located between the drain trap and the isolating valve.
7. A Y-pattern strainer, preferably fitted with a blow-down valve, should be installed upstream of the drain trap.
8. The trap discharge must be piped either to a return system or to a safe place.
9. The drain trap can be put into service by slowly opening the isolating valves. No priming is necessary.

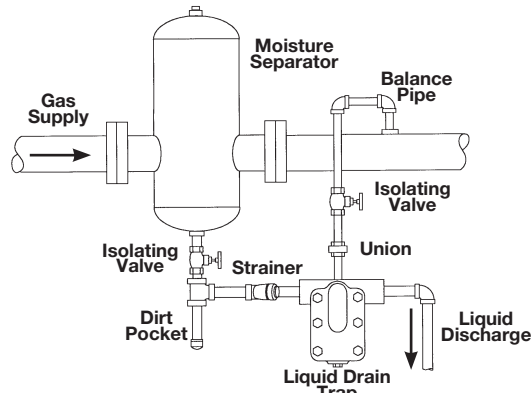

Fig.1 - Draining a Moisture Separator

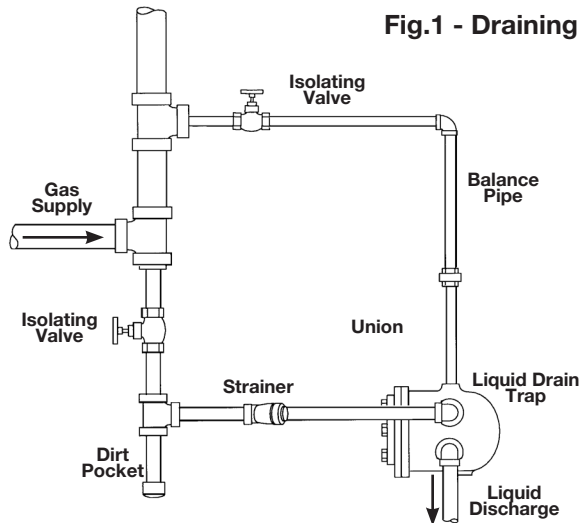

Fig. 2 - Draining a Gas Supply Line Riser

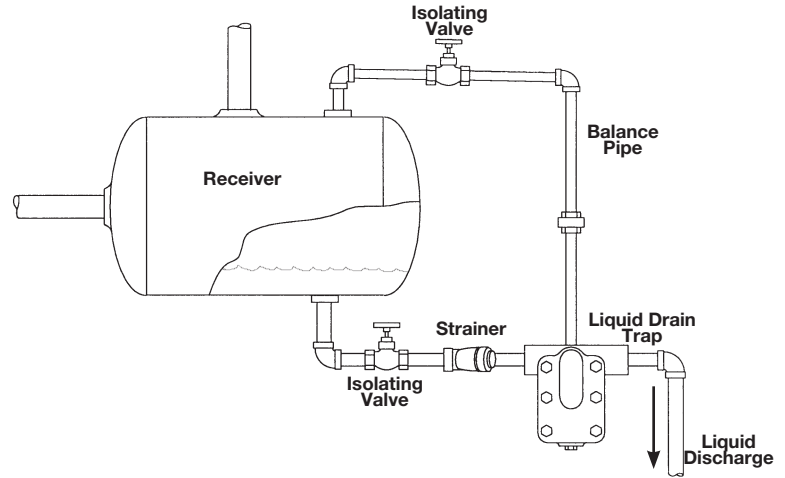

Fig. 3 - Draining a Compressed Air Receiver

## Maintenance

The drain trap must be isolated from supply, return and balance pipe pressure before servicing or disassembly. Pressure which may remain in the trap after the isolating valves are closed must be relieved before the trap is opened. This can be accomplished by opening the blowdown valve on the strainer ahead of the trap. Any special precautions required by the nature of the fluid must be observed.

1. A considerable amount of dust can be drawn into a compressed air system. This dust mixes with water and may form an emulsion with oil from the compressor. This accumulated sludge can be removed by "blowing down" through the drain in the bottom of the trap.
2. Most Spirax Sarco liquid drain traps can be serviced without disturbing the inlet and outlet piping connections. On some models it may be necessary to open the balance pipe union to permit removal of the body. Some liquid will remain in the trap body when the isolating valves are closed. This liquid may be drained by removing the plug in the bottom of the body before the trap is opened.
3. The trap should be disassembled periodically for inspection, cleaning and replacement of worn parts. After ensuring that the trap is not pressurized, remove the cover bolts and open the balance union if necessary. Remove the body or cover. Using a suitable solvent, clean all dirt, incrustation

and sludge from the body, cover and mechanism. Inspect the valve head, seat and linkage for wear or damage.

4. If the valve head and/or seat show signs of wear or wiredrawing, or if the mechanism linkage is worn or damaged, a complete new mechanism kit should be installed, following the instructions accompanying the kit.
5. If the float is leaking or visibly damaged, it must be replaced. A distorted or collapsed float is evidence of dangerous over-pressure or waterhammer conditions which must be corrected before the unit is returned to service.
6. All traces of the old cover gasket must be removed, and the gasket surfaces must be clean and undamaged. Reassemble the body and cover, using a new cover gasket. Connect the balance pipe union if necessary.
7. The mechanism and cover bolt torques shown below must be observed.
8. The drain trap can be returned to service by slowly opening the isolating valves. No priming is necessary.

### Note:

Some Spirax Sarco liquid drain traps have balanced double-seated valves which may not shut tight under no-load conditions. Normally, the liquid load will always be greater than the very small residual leakage.

## Spare Parts

The following spare parts are available for Spirax Sarco liquid drain traps:

**Valve Mechanism Kit** - Complete valve mechanism assembly with seat gasket and mounting screws as required.

**Gasket Kit** - Three each of cover and mechanism gaskets.

**Float Kit** - Float with screw and lockwasher as required.

**Note:**

In some models, the float is welded to the mechanism arm. The float is part of the valve mechanism kit, and a separate float kit is not available.

Model	Size(s)	Valve Mechanism Kit	Gasket Kit	Float Kit	Torque Values ft•lb		
					Cover Bolts	Valve Seat or mounting bolts	
FA-30	3/4", 1"	54749	55475	55447	11-14	27-31	
	1-1/2"	58132	58127	58129	17-21	90-95	
	2"	58136	58128	58130	17-21	118-122	
FA-75	3/4", 1"	54750	55475	55447	11-14	27-31	
	1-1/2"	58133	58127	58129	17-21	90-95	
	2"	58137	58128	58130	17-21	118-122	
FA-150	3/4", 1"	54751	55475	55447	11-14	27-31	
	1-1/2"	58134	58127	58129	17-21	90-95	
	2"	58138	58128	58130	17-21	118-122	
FAI-30 FAI-75 FAI-125 FAI-200	1/2", 3/4", 1"	54749 54750 54751 67048	67049	55447	17-21	27-31	
FAI-30	1-1/2"	74324	74327	74328	80-85	90-95	
FAI-200	1-1/2"	74326	74327	74328	80-85	90-95	
FA-150	1/4"	81860	66578	55447	9-11	20-25	
FA-200	1"	81850	55481	55447	17-21	8-11	
	1-1/2"	80091	55482	58130	27-31	8-11	
FAB-10	2"	58152	55479	58159	17-21	150-155	
FAB-75	1-1/2"	58179	58180	58129	23-27	8-11	
	2-1/2"	58158	58173	58160	85-90	16-19	
FAB-175	2"	61044	55479	58159	23-27	8-11	
F-150V F-300V	1/2"	63353 63354	66576	55447	15-17	17-19	
FA450	4.5 10 14 21 32	3/4"	66379	66392	N/A	24-28	27-31
			66380				
			66381				
			66382				
			66383				
FA450	4.5 10 14 21 32	1"	66384	66392	N/A	24-28	27-31
			66385				
			66386				
			66387				
			66388				
FA450	4.5 10 32	1-1/2"	66395	66393	62541	80-85	7-9
			66396				
			66397				
FA450	4.5 10 32	2"	66389	66394	62541	93-97	15-18
			66390				
			66391				
CA-14	1/2", 3/4"	1446080	1490081	N/A	29-33	37-41	
CA10S CA16S CA46S	1/2", 3/4", 1" 1-1/2" 2"	Consult Factory			21-24 44-49 59-65	29-33 7-9 15-18	



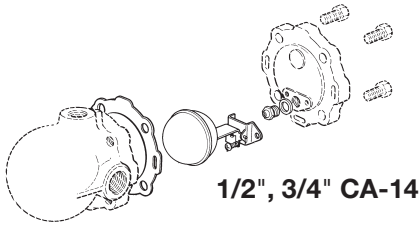

1/2", 3/4" CA-14

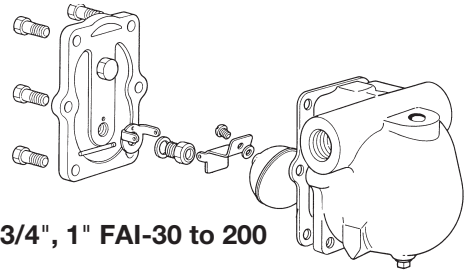

1/2", 3/4", 1" FAI-30 to 200

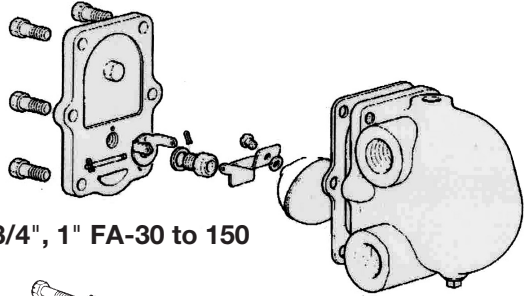

3/4", 1" FA-30 to 150

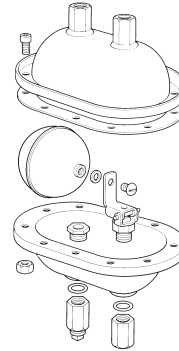

1/4" FA-150

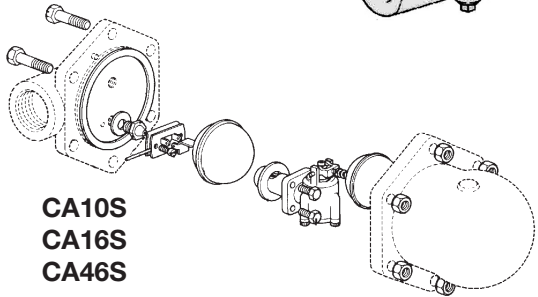

CA10S  
CA16S  
CA46S

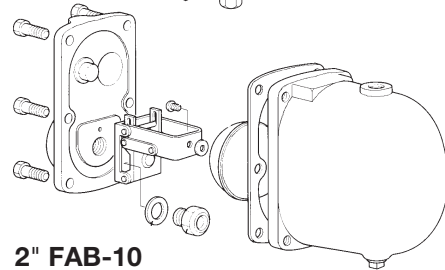

2" FAB-10

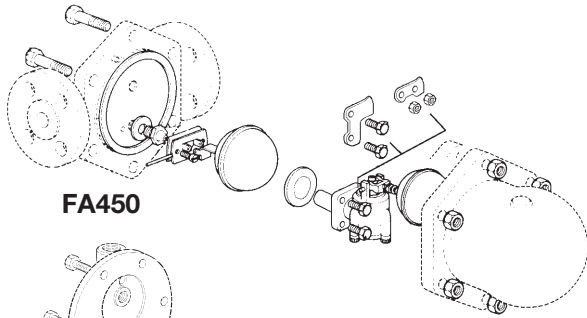

FA450

1-1/2", 2" FA-30 to 150

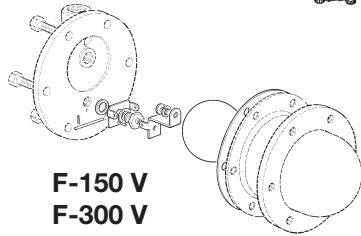

F-150 V  
F-300 V

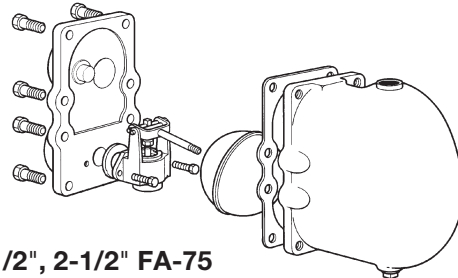

1-1/2", 2-1/2" FA-75  
2" FAB-175

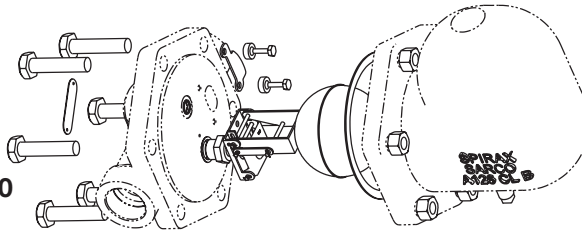

1-1/2" FAI-30 to 200

For any additional information you may require, contact: Spirax Sarco Applications Engineering Department  
Toll Free 1-800-575-0394



SPIRAX SARCO, INC. • 1150 NORTHPOINT BLVD. • BLYTHEWOOD, SC 29016  
PHONE 803-714-2000 • FAX 803-714-2222  
SPIRAXSARCO.COM/GLOBAL/US