

## EP6/PP6 Mounting Kit Assembly

HARDWARE IDENTIFICATION		
A	BRACKET	
C	LEVER 20-30	EY1 / PY1 ONLY
D	LEVER 50-80	EY2 / PY2 ONLY
H	LOCATOR 20-30	EY1 / PY1 ONLY
K	LOCATOR 50-70	EY2 / PY2 ONLY
M	PIN	
P	SPRING	
Q	SPACER	PY1 / PY2 ONLY
R	U-BOLT	UBC ONLY
S	M8 CAP HEAD SCREW	
T	M8 HEX HEAD SCREW	
U	M8 SPRING WASHER	
V	M8 PLAIN WASHER	
W	M8 NUT	
X	M6 CAP HEAD SCREW	
Y	M5 NUT	
Z	NUT, SPRING WASHER AND SCREW SUPPLIED WITH EP6 / PP6 POSITIONER	

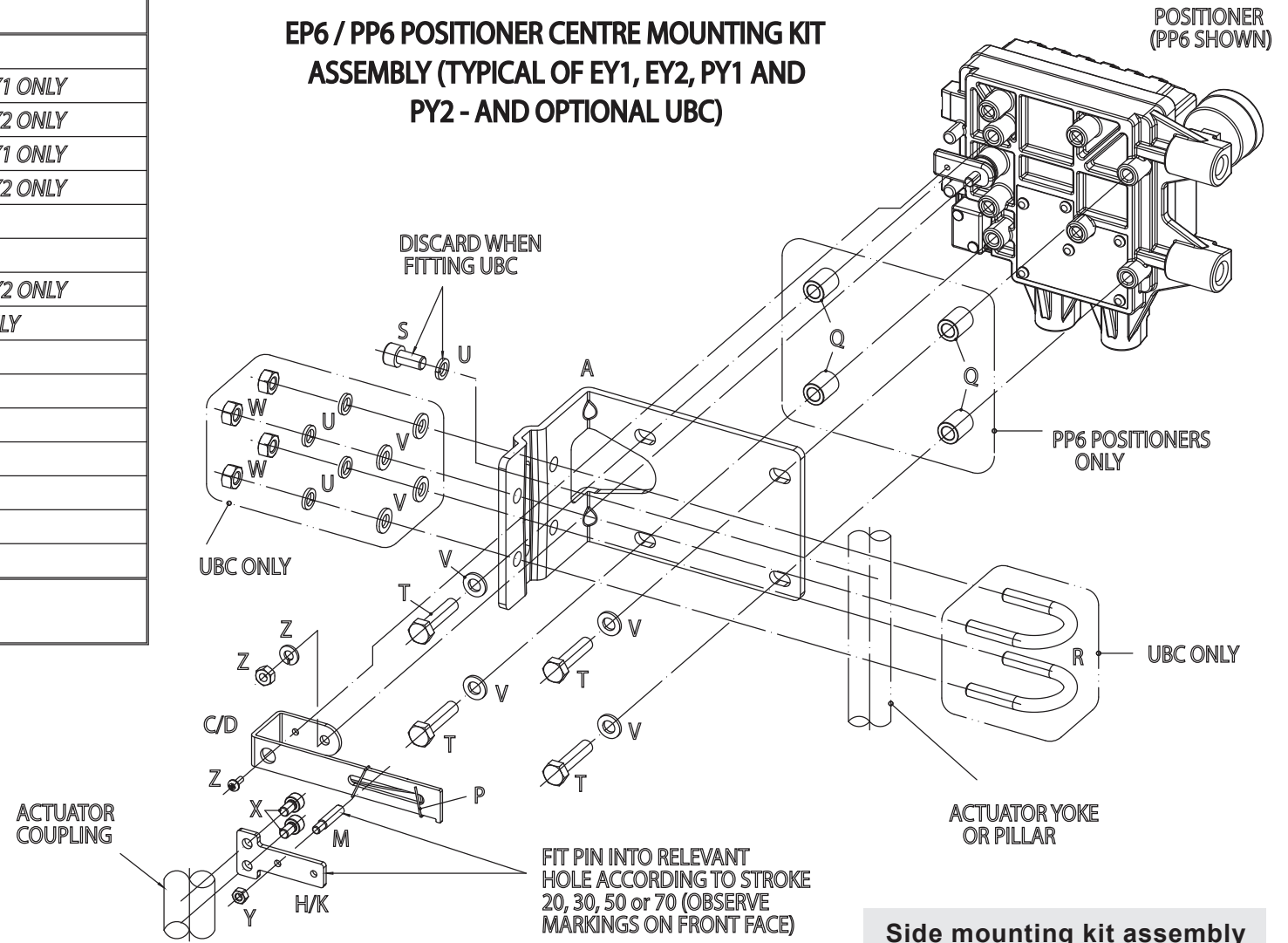

HARDWARE IDENTIFICATION		
B	BRACKET	
E	LEVER 10-40	UY3 ONLY
F	LEVER 30-70	UY1 ONLY
G	LEVER 60-100	UY2 / UY4 ONLY
J	LOCATOR 65-70-75	UY2 ONLY
L	LOCATOR - SLOTTED	UY1 / UY3 / UY4
N	PIN	
P	SPRING	
R	U-BOLT	UBC ONLY
S	M8 CAP HEAD SCREW	
T	M8 HEX HEAD SCREW	
U	M8 SPRING WASHER	
V	M8 PLAIN WASHER	
W	M8 NUT	
X	M6 CAP HEAD SCREW	
Y	M5 NUT	
Z	NUT, SPRING WASHER AND SCREW SUPPLIED WITH EP6 / PP6 POSITIONER	

## EP6 / PP6 POSITIONER SIDE MOUNTING KIT ASSEMBLY (TYPICAL OF UY1, UY2, UY3 AND UY4 - AND OPTIONAL UBC)

FIT PIN INTO RELEVANT HOLE ACCORDING TO STROKE 65, 70 or 75 (OBSERVE MARKINGS ON FRONT FACE)

UY1 / UY3 / UY4 MUST BE FITTED AND ADJUSTED ACCORDING TO APPLICATION - SEE TABLE (BOTTOM LEFT) AND FIGURE 1 (BOTTOM RIGHT) FOR DETAILS

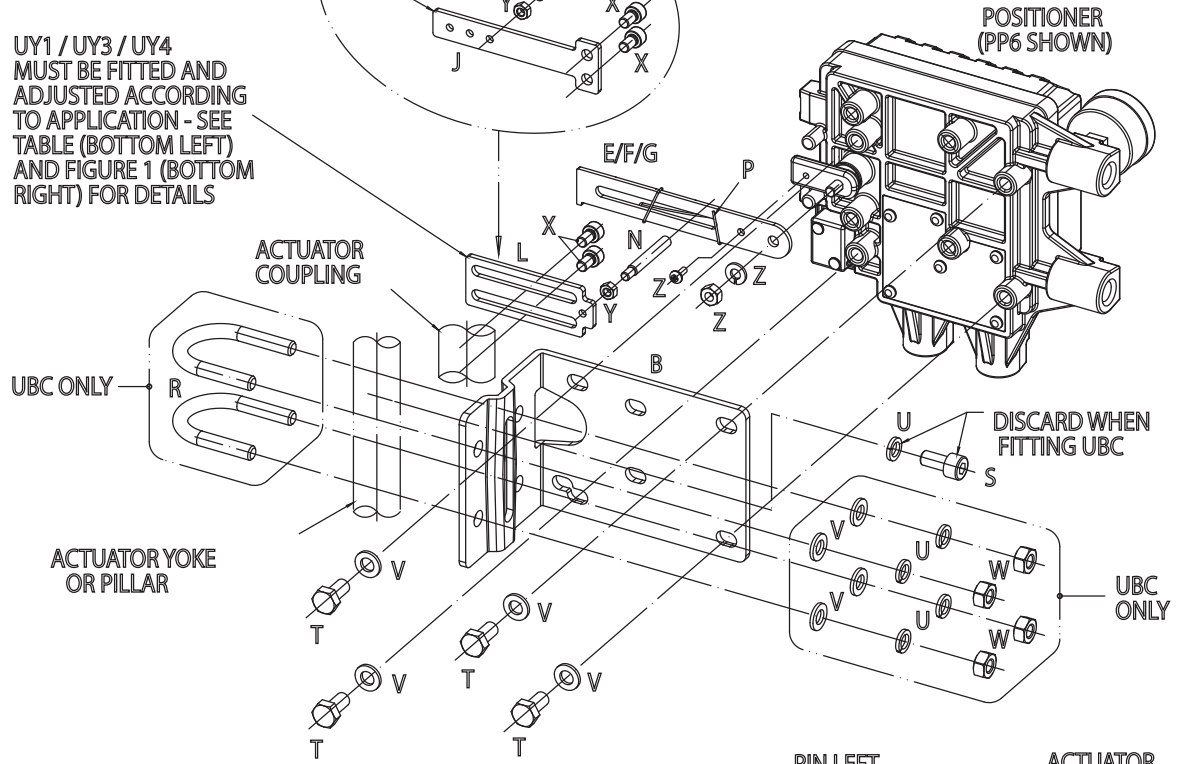

VALVE >	C SERIES		QL		SPIRA-TROL		
			DN15- DN100	DN125- DN200	DN15- DN100	DN125- DN300	
ACTUATOR	PN1600	A~R C~R					
	PN3000		D~L A~L		D~L A~L		
	PN4000		D~L A~L		D~L A~L		
	PN5000		D~L A~L		D~L A~L		
	PN9100		D~L A~L		D~L A~L		
	PN9200		D~L A~L		D~L A~L		
	PN9300		D~L A~L		D~L A~L		
	PN9400			B~R			E~R
	TN2200			B~R			E~R
	TN2300			B~R			E~R
TN2400			B~R			E~R	
STROKE mm	38 50	20 30	50	20 30	70		

'A', 'B', 'C', 'D', 'E' = CAPSCREW MARKERS  
'L' = LEFT, 'R' = RIGHT

EXAMPLE: PN9300 ACTUATOR WITH 20mm, STROKE, DN100 SPIRA-TROL VALVE = 'D~L', i.e., CAPSCREWS ALIGNED WITH 'D' MARKERS AND PIN TO LEFT OF CENTRE (SEE FIG. 1)

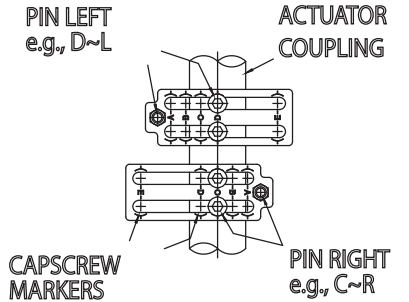

FIGURE 1