

	<p>This guide covers only a brief description of installation and maintenance for Spiratrol and QL valves. For detailed installation, operations, maintenance including safety, precautions, and warnings, please refer to our official instruction manual at www.spiraxsarco.com (IM-P703-02-US or IM-P703-04-US (ATEX)).</p>
--	---

EP6 is Electro-Pneumatic Positioner that accurately controls valve stroke in response to an input signal of 4-20 mA from the controller.

Explosion Proof Warning (Only for explosion proof type positioners)

Please ensure the unit is being used and installed in conformity with local, regional, and national explosion proof regulations.

- Explosion proof type of cables and gaskets should be used, when explosion gases are present at the installation site. Wiring should be carried out in accordance with IEC 60364 or equivalent.
- Power should be turned off completely when opening product's cover. When opening the cover, ensure that there is no power remaining in any electrical parts nearby.
- Flameproof enclosure type positioner has 2 ports for power connection. Explosion proof type wires and packing should be used. Blind plug is required when any port is not being used.
- Ring terminal with surface area of more than 1.25 mm² with M4 spring washer should be used to connect the power.
- For external ground terminal, ring terminal with surface area of more than 5.5 mm² should be used.
- There is risk of explosion due to static electricity charge. Static electricity charge may develop when cleaning the product with a dry cloth. It is imperative to avoid static electricity charge in the hazardous environment. If cleaning the surface of the product is needed, must use a damp cloth.
- To meet explosion-proof marking information and ingress protection of IP66, use certified Ex-cable glands and Ex-plugs.
- If you need additional information about the dimensions of the flameproof joints, contact Spirax Sarco directly.
- The electric valve positioner must be connected in series with a fuse with a rated current not higher than 62 mA, a breaking capacity above 1500A, and a rated voltage not less than the working voltage of the product.
- The cable entry must be equipped with a cable entry device, which must be an Ex cable entry device approved by the explosion-proof inspection agency (For NEPSI - according to the requirements of GB3836.1-2010 and GB3836.2-2010) and meet the requirements of the product explosion-proof mark, and the installation of the cable entry device, user must follow its instructions.

1. Installation

1.1 Linear positioner

1.1.1 Assemble the feedback pin locator and feedback pin to the actuator coupling firmly

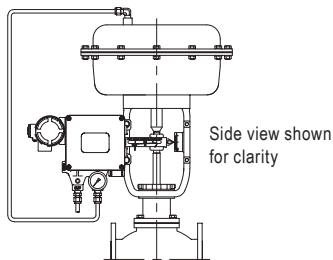

Mounting positions	Pin locator marking	Valve stroke mm	MTG kit	Feedback pin locator direction
Central	N/A	20	EY1	←
		30		
		50	EY2	
		70		
Left hand side	D	20	UY3	←
	A	30		
	B	50	UY1	→
	E	70		

- 1.1.2 Assemble the supplied feedback lever, bracket and positioner firmly, then loosely mount the assembly on the left hand side of the actuator yoke. For central mount, mount on the right hand side of the actuator yoke.
- 1.1.3 Make sure that Positioner's feedback lever is perpendicular to the valve stem at 50% of the valve stroke.

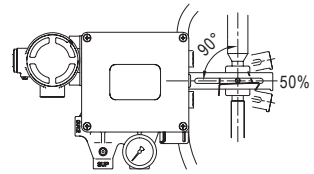

- 1.1.4 The feedback pin coming from the actuator coupling should be inserted inside slot of the feedback lever in such a way that the length of valve stroke coincides with the corresponding figures in "mm" marked on the feedback lever. Improper setting may cause poor linearity or damage to positioner.

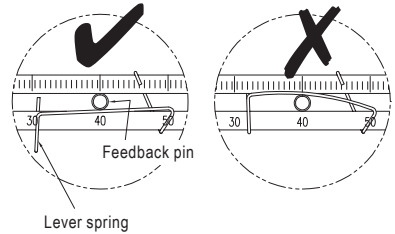

- 1.1.5 At 0% or 100% position, the linear lever or linear lever stopper should not touch the stopping bosses of positioner.
- 1.1.6 As a final step, tighten the bracket to the actuator yoke.

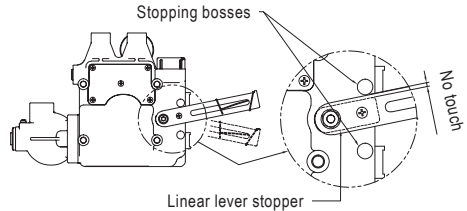
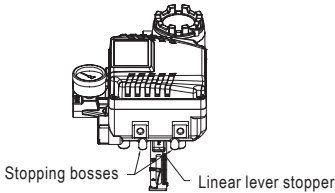

1.2 Rotary positioner

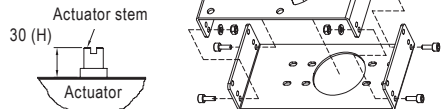
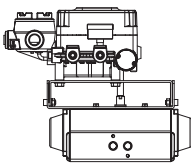

- 1.2.1 There are two brackets in the positioner box.
- 1.2.2 Refer to below and check the bolting positions of the upper and lower brackets to be fastened depending on the actuator's stem height. And then assemble the positioner with the brackets by using M6 bolts, washers and nuts.

- 1.2.3 Make sure that the center of positioner's main shaft is well aligned with the center of actuator's stem.
- 1.2.4 Tighten the positioner and bracket, taking into account the alignment described in step 3 above.

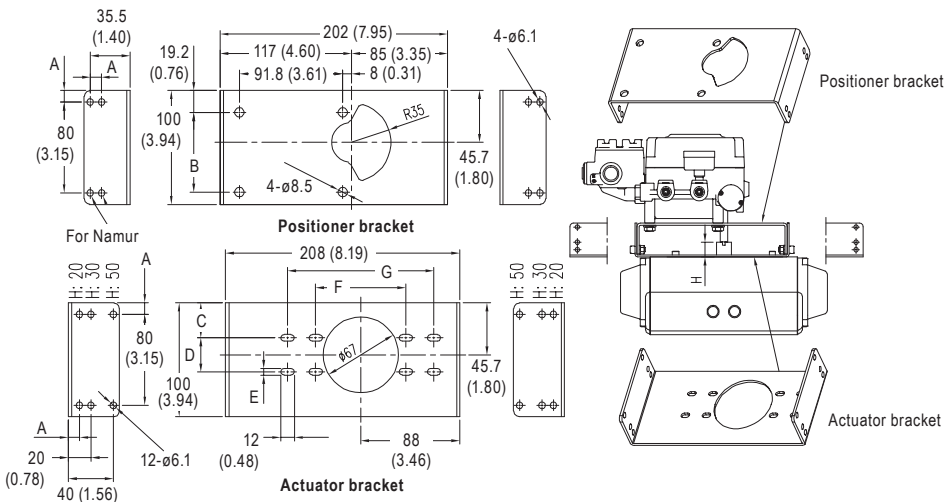

Dimensions	A 10 (0.39)	B 70 (2.76)	C 30.7 (1.21)	D 30 (1.18)	E 6 (0.24)	F 80 (3.35)	G 130 (5.12)
------------	-------------	-------------	---------------	-------------	------------	-------------	--------------

2. Connection – Air

2.1 Single acting actuator (side mount positioner)

2.1.1 Piping and span direction setting for linear DA single actuator

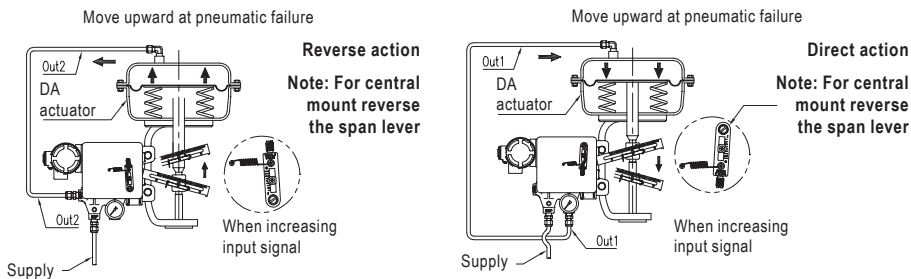

2.1.2 Piping and span direction setting for linear RA single actuator

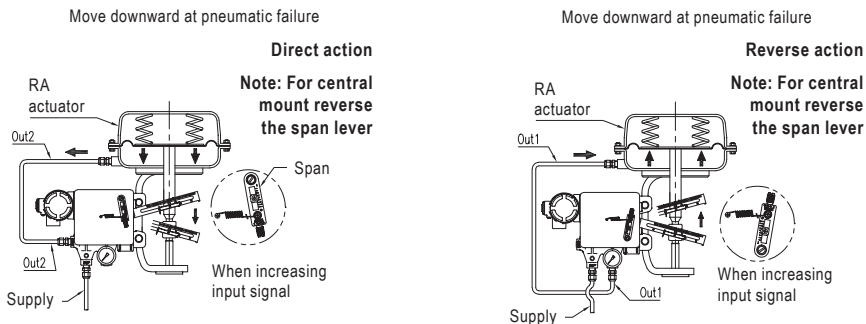

2.1.3 Piping and cam direction setting for rotary single actuator

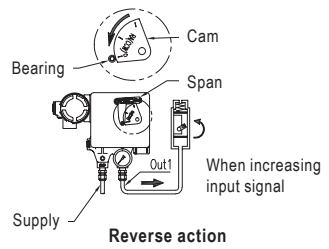
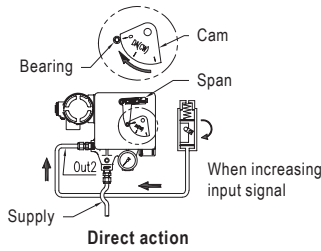

2.2 Double acting actuator (side mount positioner)

2.2.1 Piping and cam direction setting for linear double actuator

Direct action

Note: For central mount reverse the Span lever

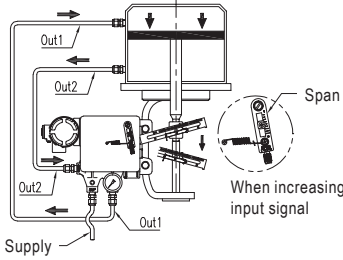

Reverse action

Note: For central mount reverse the Span lever

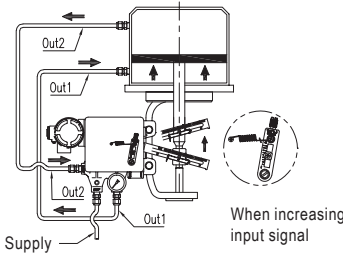

2.2.2 Piping and cam direction setting for rotary double actuator

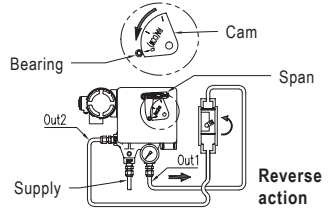
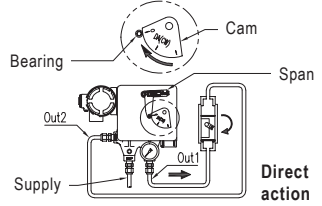

3. Connection – Power

It is recommended to use 4-20mA DC current source.

3.1 Flameproof enclosure type

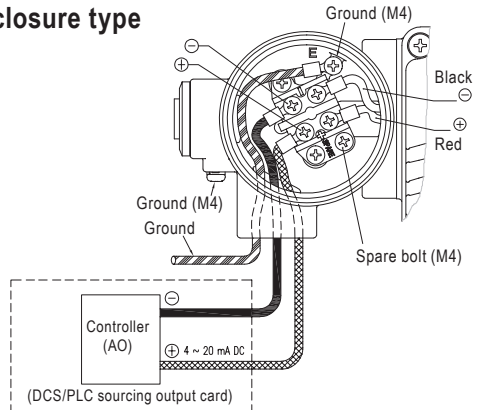

3.2 Non-explosion proof type

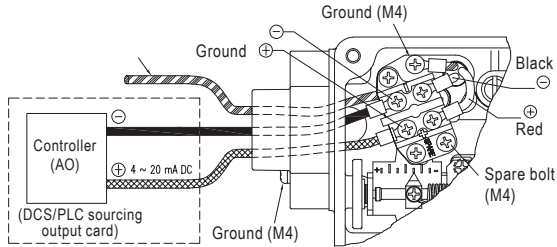

4. Adjustments

4.1 Adjustment - Zero Point

Set input signal at 4mA (or 20mA) as the initial current, then rotate the adjust wheel of zero setting unit upward or downward to set actuator's zero point. Please refer to the figure below.

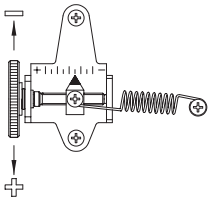

4.2 Adjustment - Span

- 4.2.1 After setting zero point, supply input signal at 20mA (or 4mA) as the end point current and check the actuator stroke. If the stroke is low, the span should be stretched. If the stroke is high, the span should be reduced.
- 4.2.2 Changing span will affect zero point setting so zero point should be set again after span has been adjusted.
- 4.2.3 Above two steps are required several times until both zero and span are properly set.
- 4.2.4 After proper setting, tighten lock screw of the span unit.

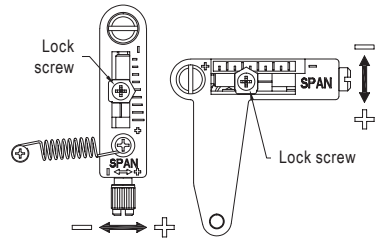

4.3 Adjustment – A/M switch (Auto/Manual)

- 4.3.1 Auto manual switch is located on the top of pilot unit. Auto manual switch allows the positioner to be functioned as bypass. If the switch is rotated counterclockwise (toward "M", Manual), then the supply pressure will be directly supplied to the actuator through Out1 port of positioner regardless of input signal. On the other hand, if the switch is turned clockwise (toward "A", Auto), then the positioner will operate normally by input signal.
- 4.3.2 Make sure that the supply pressure does not exceed the rated pressure level of the actuator before the switch is loosened toward "M".
- 4.3.3 After using the "Manual" function, return the auto manual switch to "Auto".

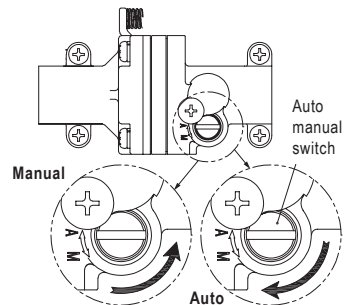

EU DECLARATION OF CONFORMITY

Apparatus model/Product: **Explosion Proof, Electro-pneumatic Positioner
EP6**

Name and address of the manufacturer or his authorised representative: **Spirax Sarco Ltd,**
Runnings Road
Cheltenham
GL51 9NQ
United Kingdom

This declaration of conformity is issued under the sole responsibility of the manufacturer.

The object of the declaration described above is in conformity with the relevant Union harmonisation legislation:

2014/30/EU EMC Directive
2014/34/EU ATEX Directive

References to the relevant harmonised standards used or references to the other technical specifications in relation to which conformity is declared:

EMC Directive EN 61000-6-4:2007 + A11:2011
EN 61000-6-2:2019

ATEX Directive EN IEC 60079-0:2018
EN 60079-1:2014
EN 60079-18:2015 + A1:2017

Where applicable, the notified body:

<i>Notified Body</i>	<i>number</i>	<i>Performed</i>	<i>Certificate</i>
Element Materials Technology Rotterdam B.V. Voorerf 18, 4824 GN Breda Netherlands	2812	<i>Issue of Quality Assurance Notification</i>	TRAC13QAN0002
Beureau Veritas Consumer Products Services Germany GmbH, Oehleckerring 40, Hamburg D-22419	2004	<i>Issue of EC Type examination certificate</i>	EPS21ATEX 1 035X

Additional information:

ATEX coding:  II 2G Ex db mb IIB T5 Gb
Ta= -20°C to +60°C

On behalf of: Spirax Sarco Ltd,

(name, function): M Sadler
Steam Business Development Engineering
Product Integrity & Compliance Manager

(place and date of issue): Cheltenham
2021-10-15

GNP234-EU-C/01 issue 3 (EN)