

EP6

Electro-pneumatic Positioner

Installation and Maintenance Instructions



1. Safety information
2. General product information
3. Installation
4. Commissioning
5. Maintenance
6. Spare parts
7. Fault finding

1. Safety information

Safe operation of these products can only be guaranteed if they are properly installed, commissioned, used and maintained by qualified personnel (see Section 1.12) in compliance with the operating instructions. General installation and safety instructions for pipeline and plant construction, as well as the proper use of tools and safety equipment must also be complied with.

1.1 Wiring

Every effort has been made during the design of the positioner to ensure the safety of the user, but the following precautions must be followed:

- i) Ensure correct installation. Safety may be compromised if the installation of the product is not carried out as specified in this manual.
- ii) Wiring should be carried out in accordance with IEC 60364 or equivalent.
- iii) Fuses should not be installed in the protective earth conductor. The integrity of the installation protective earth system must not be compromised by the disconnection or removal of other equipment.

1.2 Intended use

Referring to the Installation and Maintenance Instructions, product markings and Technical Information Sheet, check that the product is suitable for the intended use/application.

1.3 Access

Ensure safe access and if necessary a safe working platform (suitably guarded) before attempting to work on the product. Arrange suitable lifting gear if required.

1.4 Lighting

Ensure adequate lighting, particularly where detailed or intricate work is required.

1.5 Hazardous liquids or gases in the pipeline

Consider what is in the pipeline or what may have been in the pipeline at some previous time. Consider: flammable materials, substances hazardous to health, extremes of temperature.

1.6 Hazardous environment around the product

Consider: explosion risk areas, lack of oxygen (e.g. tanks, pits), dangerous gases, extremes of temperature, hot surfaces, fire hazard (e.g. during welding), excessive noise, moving machinery.

1.7 The system

Consider the effect on the complete system of the work proposed. Will any proposed action (e.g. closing isolation valves, electrical isolation) put any other part of the system or any personnel at risk?

Dangers might include isolation of vents or protective devices or the rendering ineffective of controls or alarms. Ensure isolation valves are opened and closed progressively to avoid system shocks.

1.8 Pressure systems

Ensure that any pressure is isolated and safely vented to atmospheric pressure. Consider double isolation (double block and bleed) and the locking or labelling of closed valves. Do not assume that the system has depressurised even when the pressure gauge indicates zero.

1.9 Temperature

Allow time for temperature to normalise after isolation to avoid the danger of burns.

1.10 Tools and consumables

Before starting work ensure that you have suitable tools and / or consumables available. Use only genuine Spirax Sarco replacement parts.

1.11 Protective clothing

Consider whether you and / or others in the vicinity require any protective clothing to protect against the hazards of, for example, chemicals, high / low temperature, radiation, noise, falling objects, and dangers to eyes and face.

1.12 Permits to work

All work must be carried out or be supervised by a suitably competent person. Installation and operating personnel should be trained in the correct use of the product according to the Installation and Maintenance Instructions.

Where a formal 'permit to work' system is in force it must be complied with. Where there is no such system, it is recommended that a responsible person should know what work is going on and, where necessary, arrange to have an assistant whose primary responsibility is safety. Post 'warning notices' if necessary.

1.13 Handling

Manual handling of large and / or heavy products may present a risk of injury. Lifting, pushing, pulling, carrying or supporting a load by bodily force can cause injury particularly to the back. You are advised to assess the risks taking into account the task, the individual, the load and the working environment and use the appropriate handling method depending on the circumstances of the work being carried out.

1.14 Residual hazards

In normal use the external surface of the product may be hot. Many products are not self-draining. Take due care when dismantling or removing the product from an installation (refer to 'Maintenance instructions').

1.15 Freezing

Provision must be made to protect products which are not self-draining against frost damage in environments where they may be exposed to temperatures below freezing point.

1.16 Disposal

Unless otherwise stated in the Installation and Maintenance Instructions, this product is recyclable and no ecological hazard is anticipated with its disposal providing due care is taken.

1.17 Returning products

Customers and stockists are reminded that under EC Health, Safety and Environment Law, when returning products to Spirax Sarco they must provide information on any hazards and the precautions to be taken due to contamination residues or mechanical damage which may present a health, safety or environmental risk. This information must be provided in writing including Health and Safety data sheets relating to any substances identified as hazardous or potentially hazardous.

Product return procedure

Please provide the following information with any equipment being returned:

1. Your name, Company name, address and telephone number, order number and invoice and return delivery address.
2. Description of equipment being returned.
3. Description of the fault.
4. If the equipment is being returned under warranty, please indicate:
 - i. Date of purchase
 - ii. Original order number
 - iii. Serial number

Please return all items to your local Spirax Sarco branch.

Please ensure all items are suitably packed for transit (preferably in the original cartons).

2. General product information

2.1 Introduction

The EP6 is a 2 wire loop powered positioner requiring a 4-20 mA control signal, and is designed for use with linear and rotary pneumatic valve actuators. The positioner compares the electrical signal from a controller with the actual valve position and varies a pneumatic output signal to the actuator accordingly. The mounting kit is suitable for all pneumatic actuators compliant with the NAMUR standard.

2.2 Label description

- **Model** Indicates the model number and additional symbols.
- **Ingress protection** Indicates enclosure protection grade.
- **Input signal** Indicates input signal range.
- **Operating temperature** Indicates the allowable operating temperature.
- **Ambient temperature** Indicates the allowable ambient temperature.
- **Supply pressure** Indicates the supply pressure range.
- **Serial number** Indicates unique serial number.
- **Year. Month** Indicates manufactured year and month.

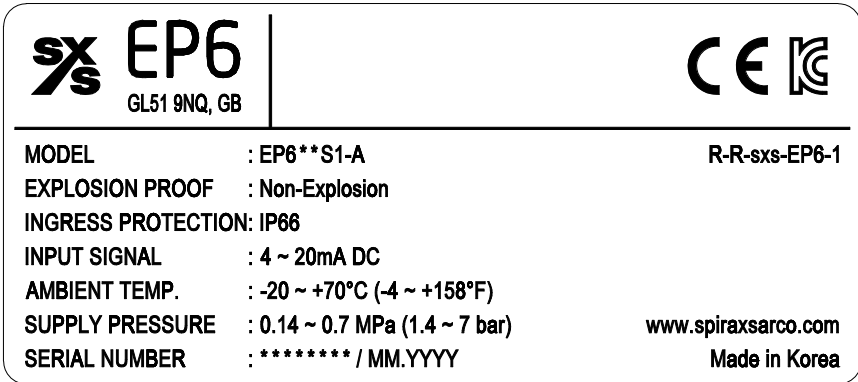

Fig. 1 EP6 Safe nameplate

2.3 Operating principle

2.3.1 Linear positioner

When INPUT SIGNAL is supplied to the positioner to open the valve, power is generated from the torque motor (1) and pushes the flapper (2) to the opposite side of the nozzle (3).

The gap between the nozzle (3) and the flapper (2) becomes wider and from inner part of the pilot (4), air inside the chamber (9) is exhausted through the nozzle (3).

Due to this effect, the spool (5) moves to the right.

Then chamber's (10) pressure will increase and when there is enough pressure inside the chamber to push the actuator's spring (11), actuator's stem (12) will start to go down and through the feedback lever, stem's linear motion will be converted to span lever's rotary motion (14).

Then chamber's pressure will increase and when there is enough pressure inside the chamber to push the actuator's spring, actuator's stem will start to go down and through the feedback lever, stem's linear motion will be converted to span lever's rotary motion.

This 14 span lever's rotary motion will then once again rotate the span (15) and pulls the span spring (16)

When the valve's position reaches to given input signal, span spring's (16) pulling force and torque motor's (1)power will be balanced and move the flapper (2) back its original position to reduce the gap with the nozzle.(3)

The amount of air being exhausted through the nozzle (3) will reduce and the chamber (9) pressure will increase again.

The spool (5) will move back to its original position on the left and the poppet (8) will also move in same direction blocking the seat (7) to stop the air coming into the chamber (10) through the SUPPLY.

As a result, the actuator will stop operating and the positioner will return to its normal condition.

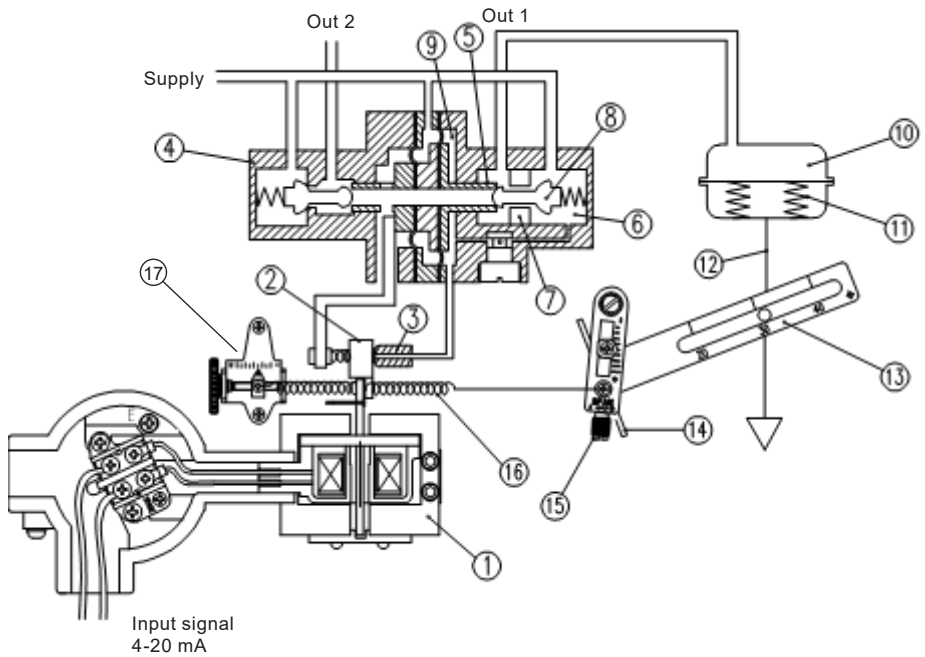

- | | |
|------------------|-------------------------------|
| 1 Torque motor | 10 Chamber of the actuator |
| 2 Flapper | 11 Actuator spring |
| 3 Nozzle | 12 Actuator stem |
| 4 Pilot | 13 Feedback Lever |
| 5 Spool | 14 Span lever (rotary motion) |
| 6 Supply chamber | 15 Span adjuster |
| 7 Seat | 16 Span spring |
| 8 Poppet | 17 Zero adjuster |
| 9 Chamber | |

Fig. 2 Linear positioner with an actuator

2.3.2 Rotary positioner

When INPUT SIGNAL is supplied to the positioner to open the valve, power is generated from the torque motor (1) and pushes the flapper (2) to the opposite side of the nozzle (3).

The gap between the nozzle (3) and the flapper (2) becomes wider and from inner part of the pilot (4), air inside the chamber (9) is exhausted through the nozzle (3).

Due to this effect, the spool (5) moves to the right.

Then the spool pushes the poppet (8) away from the seat (7) which was blocked by the poppet and the supplied pressure (air) goes through the seat (7) and OUT1 Port and enters into the chamber (10) of the actuator through OUT1.

Then chamber's (10) OUT1 pressure will increase and (11) the actuator's stem will rotate and through the feedback shaft (12), actuator's rotating motion will be transferred to the cam (13).

This motion will then rotate the span lever (14) and pull the span's spring (15).

Once it reaches to given input signal, span spring's (15) pulling force and torque motor's (1) power will be balanced and move the flapper (2) back its original position to reduce the gap with the nozzle (3).

The amount of air being exhausted through the nozzle (3) will reduce and chamber pressure (9) will increase again.

The spool (5) will move back to its original position on the left and the poppet (8) will also move in same direction blocking the seat (7) to stop the air coming into the chamber (10) through the SUPPLY.

As a result, the actuator will stop operating and the positioner will return to its normal condition.

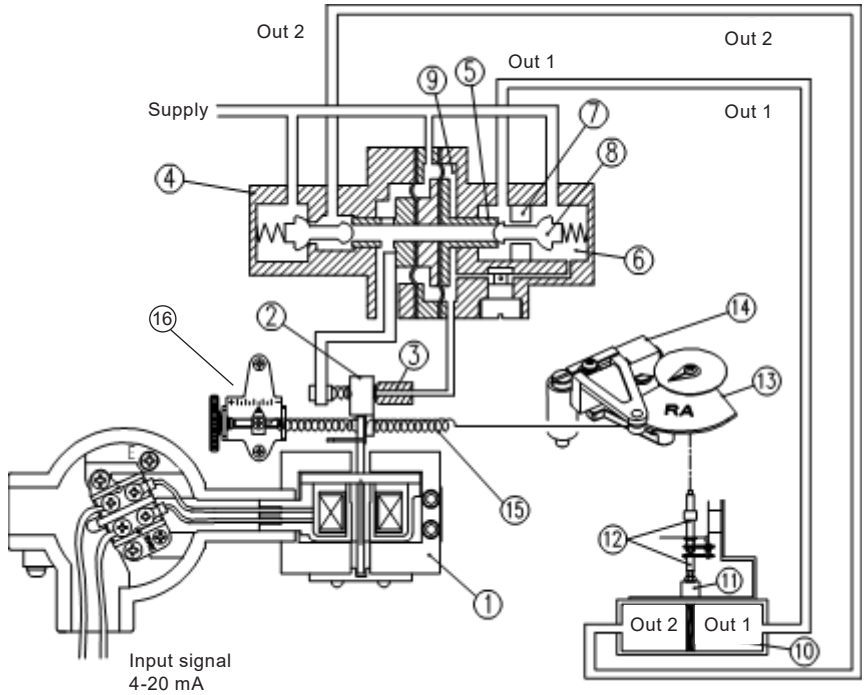

- | | |
|------------------|----------------------------|
| 1 Torque motor | 9 Chamber |
| 2 Flapper | 10 Chamber of the actuator |
| 3 Nozzle | 11 Actuator spring |
| 4 Pilot | 12 Actuator stem |
| 5 Spool | 13 Cam |
| 6 Supply chamber | 14 Span lever |
| 7 Seat | 15 Span spring |
| 8 Poppet | 16 Zero adjuster |

Fig. 3 Rotary positioner with an actuator

3. Installation

Note: Before starting any installation observe the 'Safety information' in Section 1.

This document is provided as a guide and it is recommended that it is read thoroughly prior to installation. Also refer to the separate Installation and Maintenance Instructions for the control valve and actuator.

3.1 Safety

When installing a positioner, please ensure to read and follow safety instructions.

- Any input or supply pressures to valve, actuator, and / or to other related devices must be turned off.
- Use bypass valve or other supportive equipment to avoid entire system "shut down".
- Ensure there is no remaining pressure in the actuator.
- The positioner has a vent cover to exhaust internal air and drain internal condensation water.



When installing the positioner, make sure the vent cover is facing downwards. Otherwise, the condensation water could cause corrosion and damage to internal parts.

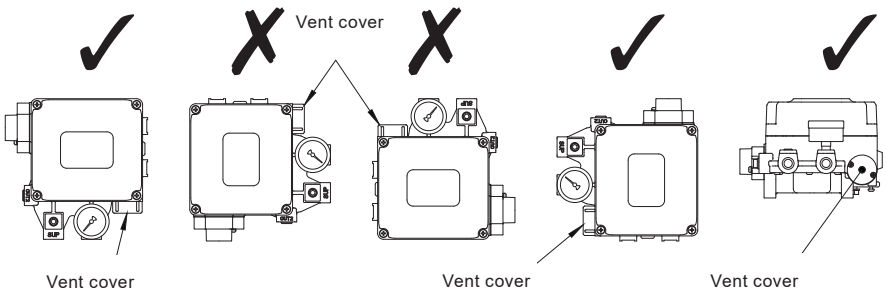

Fig. 4 The correct positions of a vent cover

3.2 Location

The positioner should be mounted in sufficient space to allow opening of the cover and provide access to connections. When fitting to an actuator, ensure the positioner will not be exposed to an ambient temperature outside the range -4 °F to +158 °F. The positioner enclosure is rated to IP66. Connection of air supply pressure (20 to 100 psi g) and control signal (4 - 20 mA) should be considered prior to choice of location.

3.3 Tools for installation

- Hex key set for hex socket cap bolts
- (+) & (-) Screw drivers
- Spanners for hexagonal-head bolts

3.4 Linear positioner Installation

Linear positioner should be installed on linear motion valves such as globe or gate type which uses spring return type diaphragm or piston actuators.

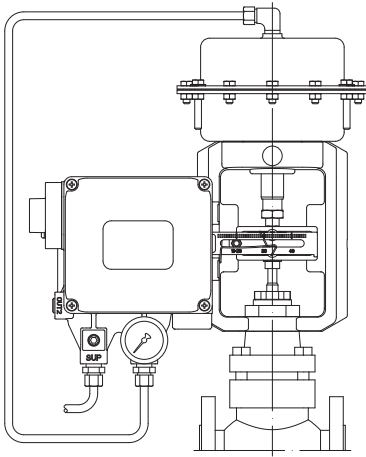

Mounting Positions	Pin Locator Marking	Valve stroke (mm)	MTG kit	Feedback pin locator direction
Central	N/A	20	EY1	←
		30		
		50	EY2	
		70		
Left hand side	D	20	UY3	←
	A	30		
	B	50	UY1	→
	E	70		

Fig. 5 Installation example

Before proceeding with the installation, ensure following components are available.

- Positioner
- Mounting kit
- Air supply pipe and couplings
- Signal pipe and couplings to actuator
- Conduit gland connector

3.5 Installation Steps

3.5.1 Central mount

1. Assemble feedback lever to positioner, retaining with screw & M6 nut.
2. Assemble mounting bracket onto back of positioner, by feeding feedback lever through opening in bracket, retain using 4 off M8 screws and washers
3. Assemble feedback pin to feedback pin locator and secure with nut. Secure feedback pin locator to actuator coupling with M6 cap screws, ensuring feedback pin is to the left of actuator centre line.
4. Connect air supply to actuator to position valve to mid travel, see Fig. 9
5. Assemble positioner onto actuator, ensuring feedback pin engages with feedback lever and tensioning spring is the correct side of feedback pin, see Fig. 8. Move positioner up or down, so that feedback lever is horizontal.

Secure mounting bracket to actuator yoke using M8 screw & spring washer (or 'U' bolts if applicable).

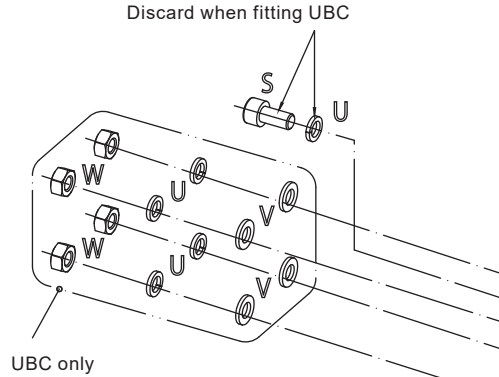

Hardware identification

A	Bracket	
C	Lever 20-30	EY1/PY1 only
D	Lever 50-80	EY2/PY2 only
H	Locator 20-30	EY1/PY1 only
K	Locator 50-80	EY2/PY2 only
M	Pin	
P	Spring	
O	Spacer	PY1/PY2 only
R	U-bolt	UBC only
S	M8 cap head screw	
T	M8 hex head screw	
U	M8 spring washer	
V	M8 plain washer	
W	M8 nut	
X	M6 cap head screw	
Y	M5 nut	
Z	Nut, spring washer and screw supplied with EP6/PP6 positioner	

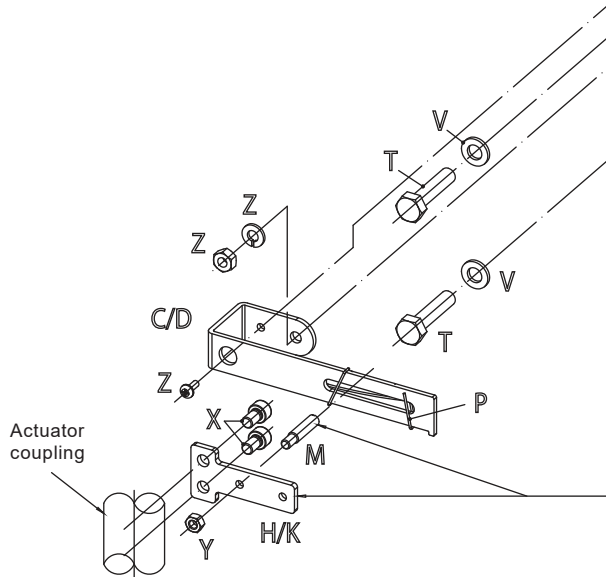

Positioner
(PP6 shown)

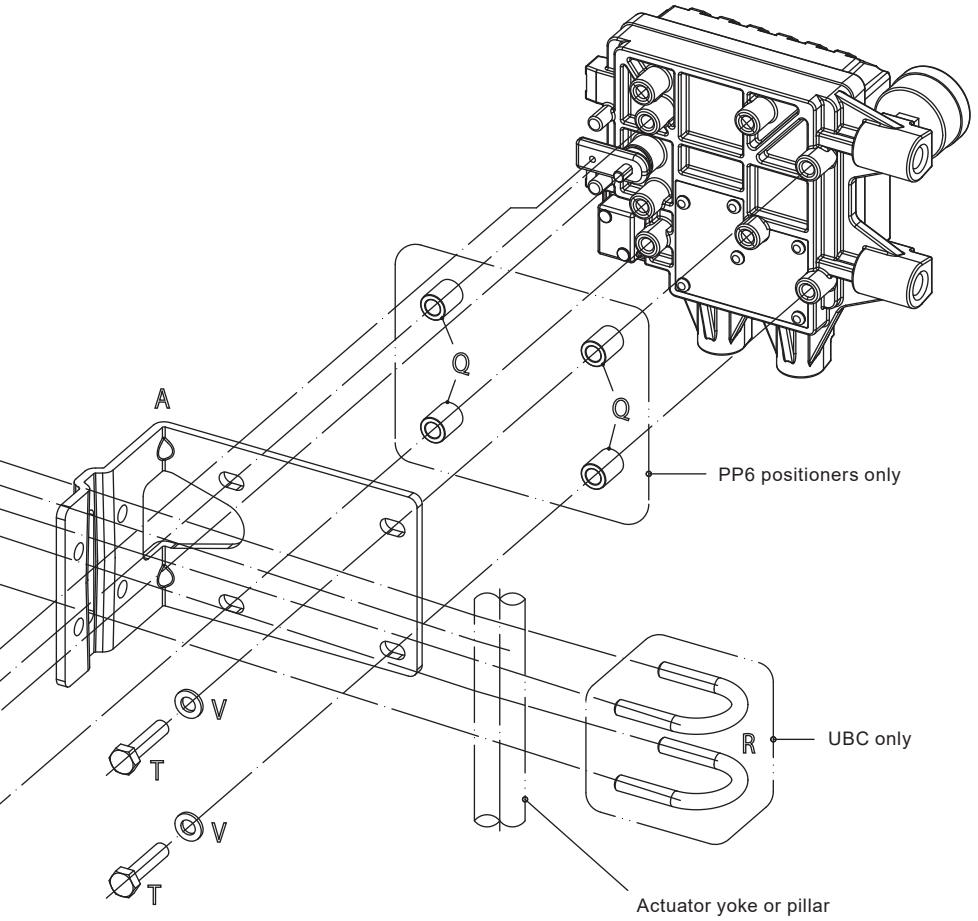

Fit pin into relevant hole according to stroke 20, 30, 50 or 70 mm (observe markings on front face)

Fig. 6
Exploded view of central mount assembly
(PP6 positioner shown, for EP6 spacers are not required)

EP6 Electro-pneumatic Positioner

3.5.2 Side mount

1. Assemble feedback lever to positioner, retaining with screw & M6 nut.
2. Assemble mounting bracket onto back of positioner, retain using 4 off M8 screws and washers.
3. Assemble feedback pin to feedback pin locator, and secure with nut. Secure feedback pin locator to actuator coupling with M6 cap screws, ensuring feedback pin locator is positioned according to feedback pin locator table.
4. Connect air supply to actuator to position valve to mid travel, see Fig. x.
5. Assemble positioner onto actuator, ensuring feedback pin engages with feedback lever and tensioning spring is the correct side of feedback pin, see Fig. x. Move positioner up or down, so that feedback lever is horizontal.

Secure mounting bracket to actuator yoke using M8 screw & spring washer (or 'U' bolts if applicable).

Hardware identification

B	Bracket	
E	Lever 10-40	UY3 only
F	Lever 30-70	UY1 only
G	Lever 60-100	UY2/UY4 only
J	Locator 65-70-75	UY2 only
L	Locator - slotted	UY1/UY3/UY4
N	Pin	
P	Spring	
R	U-bolt	UBC only
S	M8 cap head screw	
T	M8 hex head screw	
U	M8 spring washer	
V	M8 plain washer	
W	M8 nut	
X	M6 cap head screw	UY1/UY3/UY4
Y	M5 nut	
Z	Nut, spring washer and screw supplied with EP6/PP6 positioner	

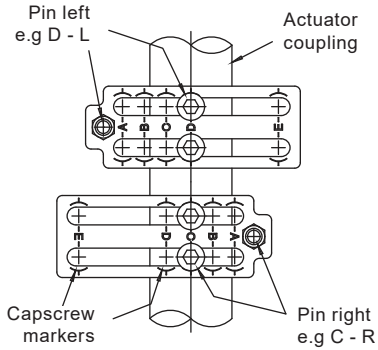
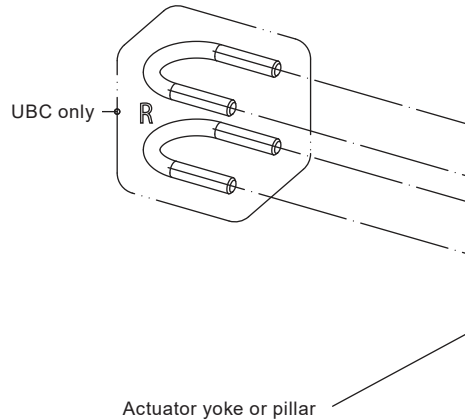

Fig. 7.1
Mounting position for feedback pin locator

Please contact James Lambert for clarification. Thanks



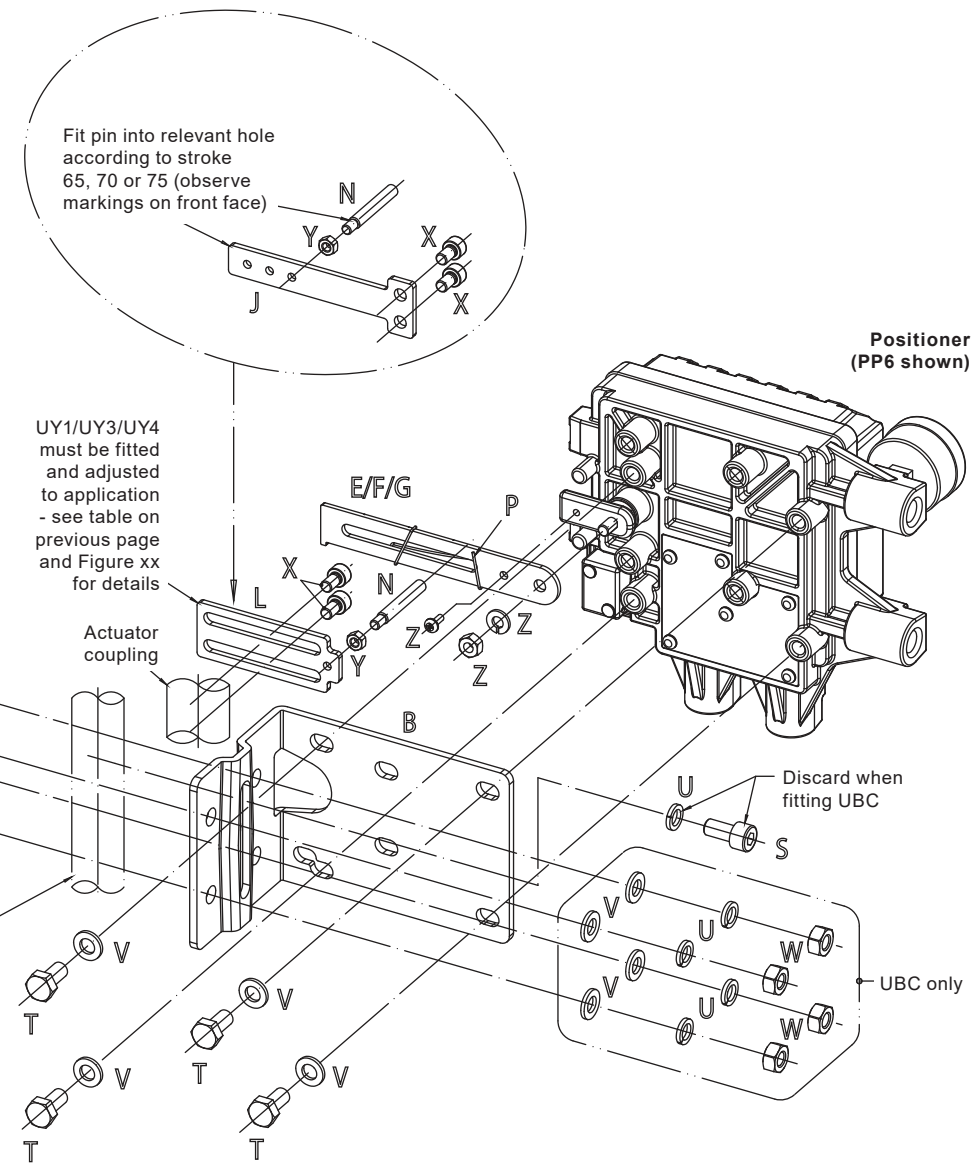

Fig. 7.2 Exploded view of side mount assembly (PP6 positioner shown)

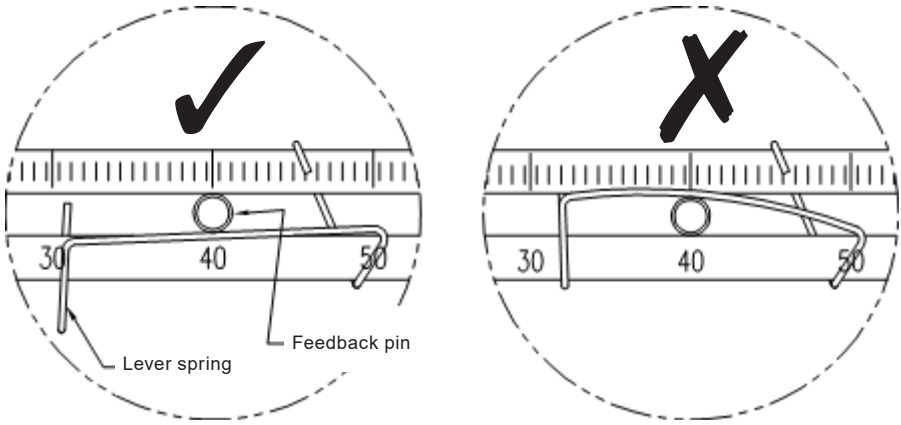

Fig. 8 Proper way to insert feedback pin between feedback lever and lever spring

Fig. 9 Feedback lever and valve stem

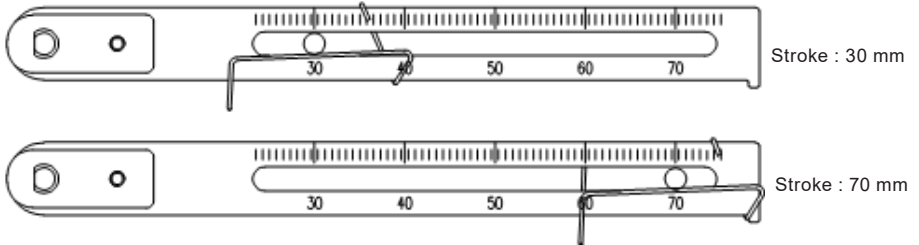
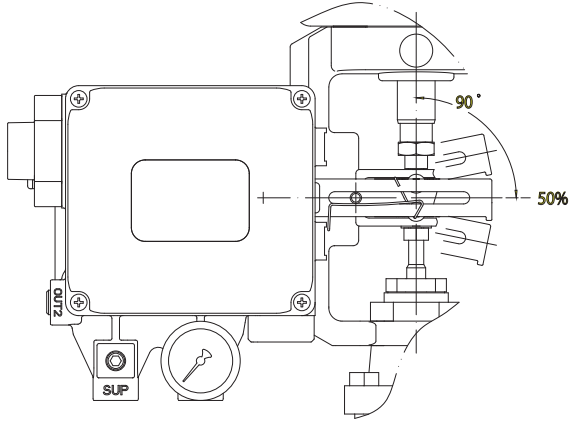

Fig. 10 Feedback lever and location of the feedback pin

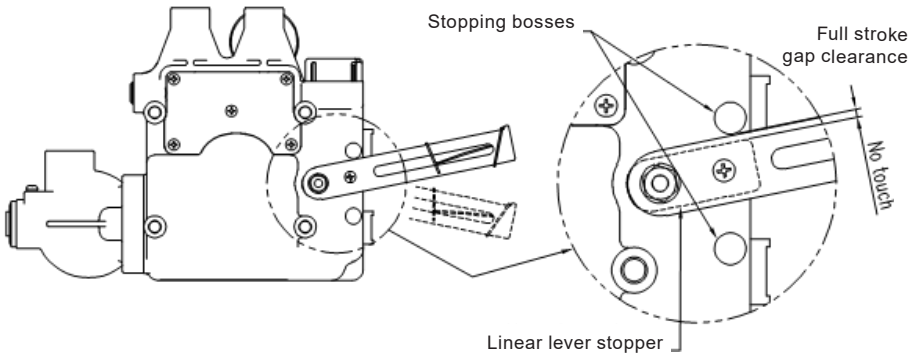

Fig. 11

Linear lever stopper should not touch stopping bosses of positioner on 0% ~ 100% valve stroke.

3.6 Rotary positioner Installation

Rotary positioner should be installed on rotary motion valve such as ball or butterfly type which uses rack and pinion, scotch yoke or other type of actuators which its stem rotates 90 degrees. Before proceeding with the installation, ensure following components are available.

Components

- Positioner
- Rotary bracket set (2 pieces)
- Mounting kit
- Air supply pipe and couplings
- Signal pipe and couplings to actuator
- Conduit gland connector

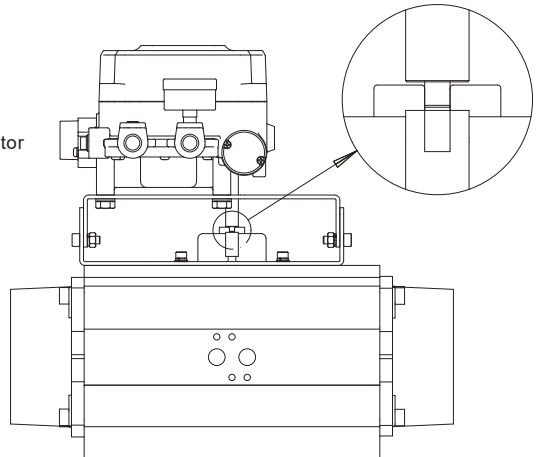
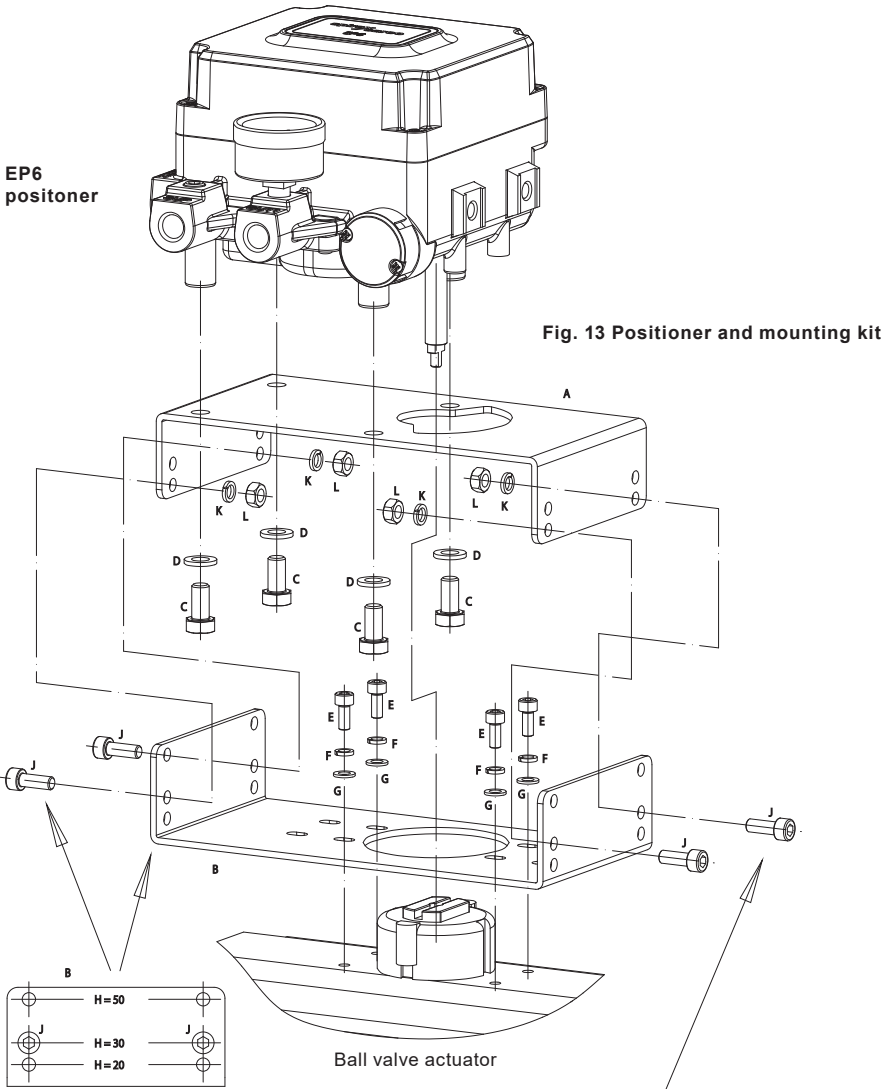

Fig. 12 Namur type

3.7 Rotary Bracket Information

The rotary bracket set (included with the positioner) contains two components. The bracket is designed to fit onto the actuator with 20 mm, 30 mm and 50 mm stem height (H) according to VDI/VDE 3845 standard. Please refer to below figures how to adjust the height of the bracket.



Choose correct holes according to actuator stem height (H) See Figure 14 (both ends)

Hardware identification

A	Bracket (positioner)	1 off
B	Bracket (actuator)	
C	M8 hex head screw	
D	M8 plain washer	
E	M5 cap head screw	
F	M5 spring washer	
G	M5 plain washer	4 off
J	M6 cap head screw	
K	M6 spring washer	
L	M6 nut	

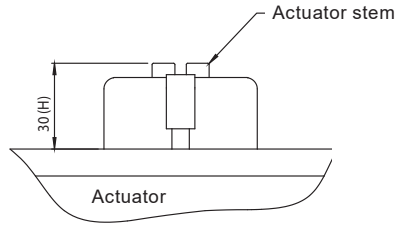

Fig. 14 Actuator stem Height

3.8 Rotary positioner Installation Steps

1. Spirax actuator (BVA300) stem height is 30mm, assemble brackets as shown in Fig. 13
2. Please note, set rotation position of the actuator stem as shown in Fig. 13 when assembling, especially important for double acting actuators.

3.9 Connecting up

3.9.1 Pneumatic connections

Warning: Air supply must be dry, oil and dust free to ISO 8573-1:2010 Class 3:3:3. Dirty air supply may damage the product and invalidate warranty.

For best performance, set the air supply pressure to about 7.5 psi g above the pressure required to fully travel the actuator.

Check all connections for leaks. Please note however that the EP6 bleeds air in normal operation at a rate of approximately 0.09 SCFM at 20 psi supply pressure.

Pneumatic connections are located at the left hand side and bottom of the positioner and are identified as follows 'SUPPLY' and 'OUT':

SUPPLY - Air supply - 20 psi to 100 psi g, depending upon required actuator spring range.

OUT - Output signal to the actuator.

Connections are 1/4" NPT female. Interconnection between the positioner and the actuator should be at least 6 mm OD tube.

3.9.2 Air connection - Single acting actuator (Side mount positioner)

3.9.2.1 - Piping and span direction setting for linear DA single actuator

*EP6 ATEX shown for reference

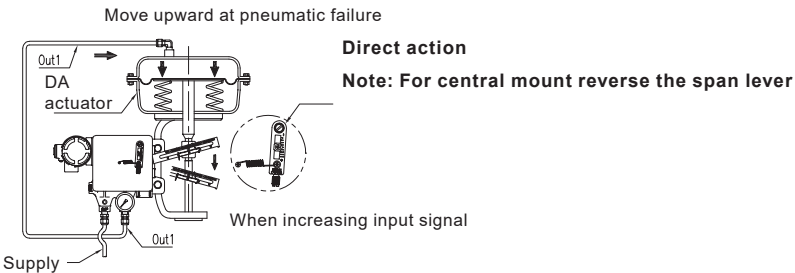
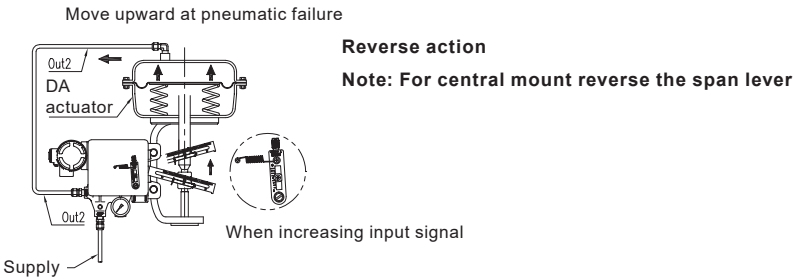

3.9.2.2 - Piping and span direction setting for linear RA single actuator

Move downward at pneumatic failure

Direct action

Note: For central mount reverse the span lever

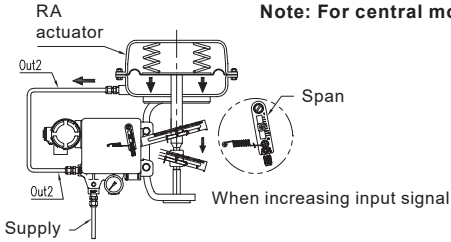

Move downward at pneumatic failure

Reverse action

Note: For central mount reverse the span lever

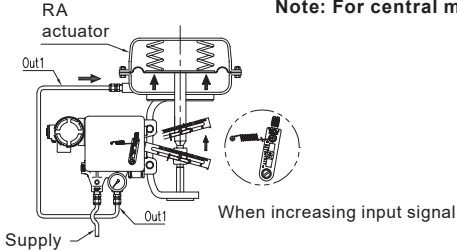

3.9.2.3 - Piping and cam direction setting for rotary single actuator

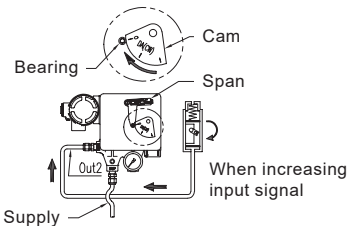

Direct action

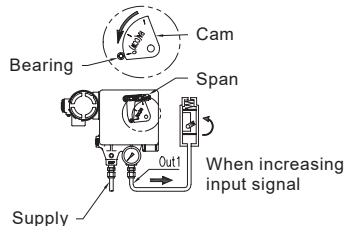

Reverse action

3.9.3 Double acting actuator (side mount positioner)

3.9.3.1 Piping and cam direction setting for linear double actuator

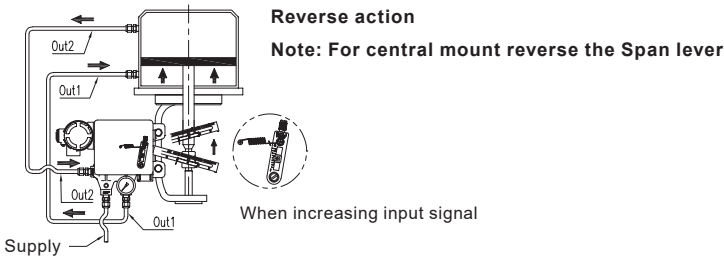
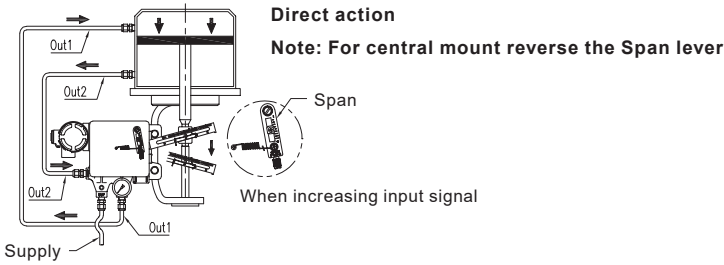

3.9.3.2 Piping and cam direction setting for rotary double actuator

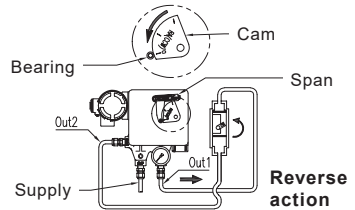
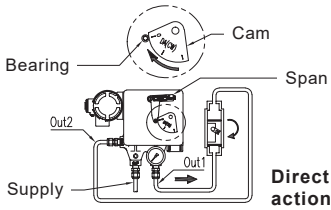

3.9.4 Electrical connections

The EP6 only requires a 4 - 20 mA signal. Unscrew cover.

Note: Ensure resistance from earth post to local earth (e.g. pipework) is less than 1 Ohm. Connection to the unit is through the conduit entry port, using a suitable cable gland (not supplied). Connect conductors (0.5 to 2.5 mm²) to the terminal blocks and earth noting the polarity +/-.

4. Commissioning

4.1 RA or DA Setting

4.1.1 Linear Positioner

- 1) Side mount - If the actuator axis moves down when input signal is increased, assemble the "Span" to upper M6 Tap hole like the below Fig. 15.(DA)
Central mount - If the actuator axis moves down when input signal is increased, assemble the "Span" to lower M6 Tap hole like the below Fig. 17. (DA)

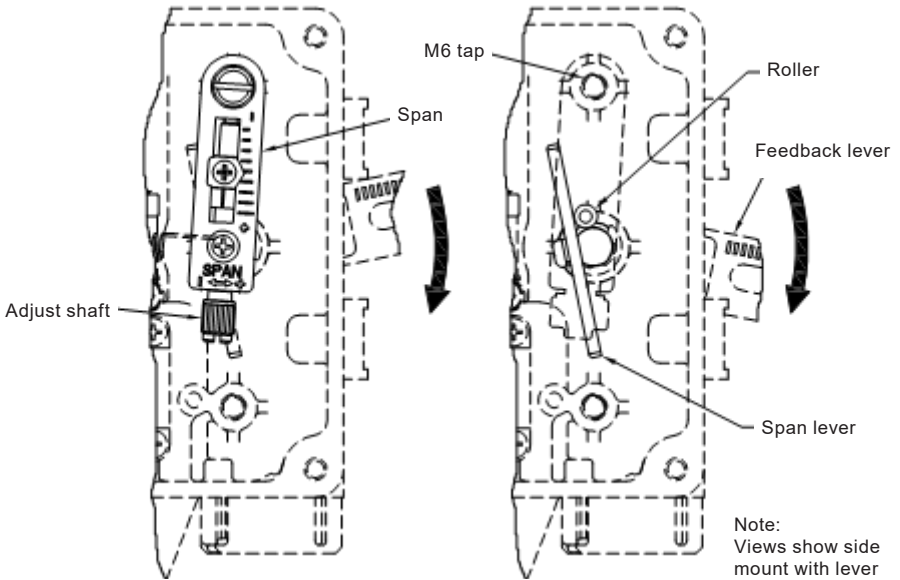

Fig. 15 Span Installation (side = DA, central = RA)

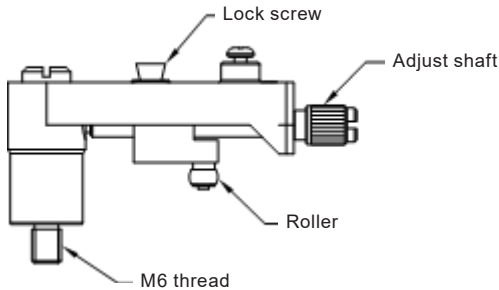

Fig. 16 Linear span assembly

- 2) Side mount - If the actuator axis moves up when input signal is increased, assemble the "Span" to lower M6 Tap hole like the below Fig. 15.(RA)
 Central mount - If the actuator axis moves up when input signal is increased, assemble the "Span" to upper M6 Tap hole like the above Fig. 17 (RA)

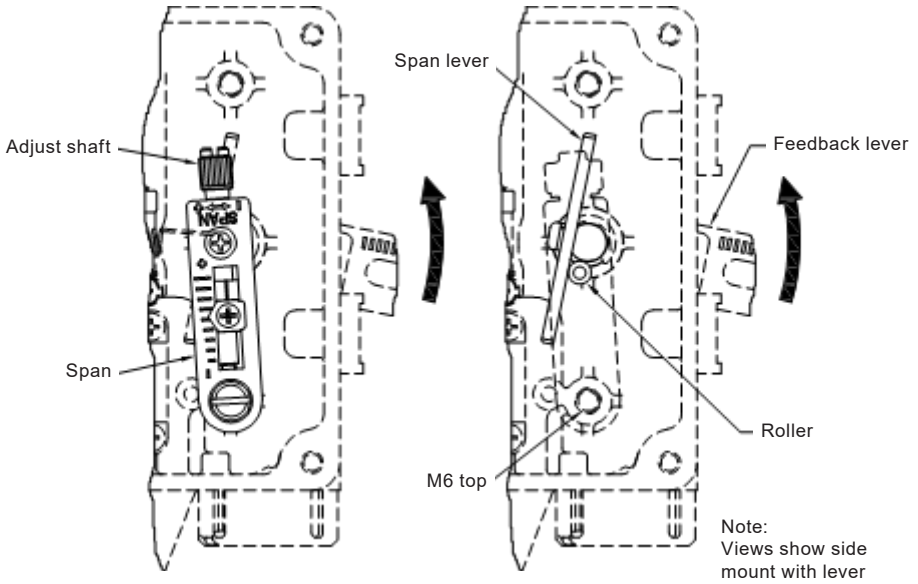

Fig. 17 Span Installation (side = RA, central = DA)

4.4 Rotary positioner

- 1) If the actuator axis rotates clockwise when input signal is increased, If required, re-assemble the CAM so that "DA(Direct Acting)" lettered surface is facing upward.
- 2) If the actuator axis rotates counter-clockwise when input signal in increased, If required, re-assemble the CAM so that "RA(Reverse Acting)" lettered surface is facing upward.
- 3) Position the actuator to initial point.
- 4) Adjust the CAM so that the engraved CAM reference line marked with "0" is placed in the center of the span bearing and fix it by tightening the nut.

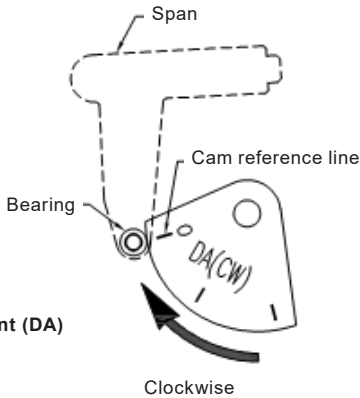

Fig. 18
Cam Installment (DA)

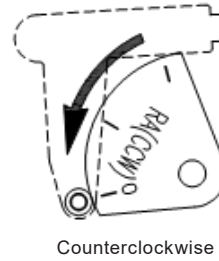

Fig. 19 Cam Installment (RA)

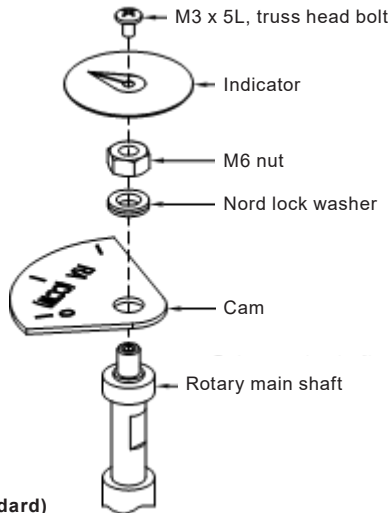

Fig. 20
Parts (Standard)

4.5 Adjustment - Zero Point

Set input signal at 4mA (or 20mA) as the initial ampere and rotate the adjuster of zero unit handle upward or downward to adjust actuator's zero point. Please refer to the below figure to increase or decrease the zero point.

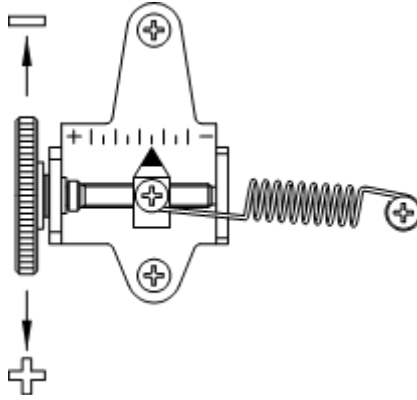

Fig. 21 Zero unit

4.6 Adjustment - Span

- 1) After setting zero point, supply input signal at 20mA (or 4mA) as the end ampere and check the actuator stroke. If the stroke is too low, the span should be increased. If the stroke is too high, the span should be decreased.
- 2) Changing span will affect zero point setting so zero point should be set again after span has been adjusted.
- 3) Above two steps are required several times until both zero and span are properly set.
- 4) After proper setting, tighten lock screw.

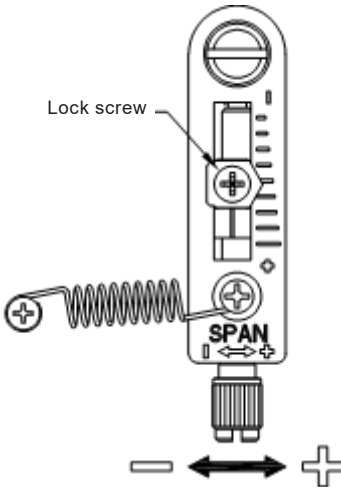

Fig. 22 Linear span unit

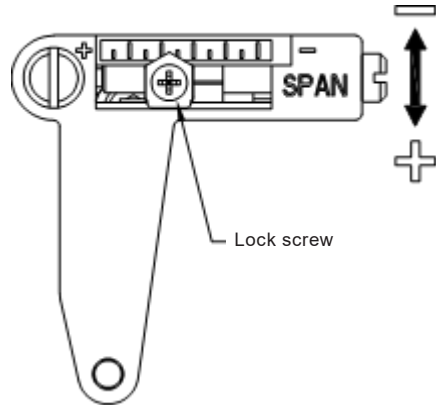

Fig. 23 Rotary span unit

4.7 Adjustment – A/M switch (Auto/Manual)

- 1) Auto/Manual switch is on the top of pilot unit. Auto/Manual switch allows the positioner to be by-passed. If the A/M switch is turned counter-clockwise (towards "M", Manual), then the supply pressure will be directly supplied from OUT1 port of positioner to the actuator regardless of input signal. On the other hand, if the switch is turned clockwise (toward "A", Auto) and it is fastened tightly, then the positioner will operate normally by input signal. It is extremely important to check the allowed pressure level of the actuator when the switch is loosened.
- 2) Check whether the supply pressure is too high.
- 3) After using "Manual" function, Auto/Manual switch should be returned to "Auto".

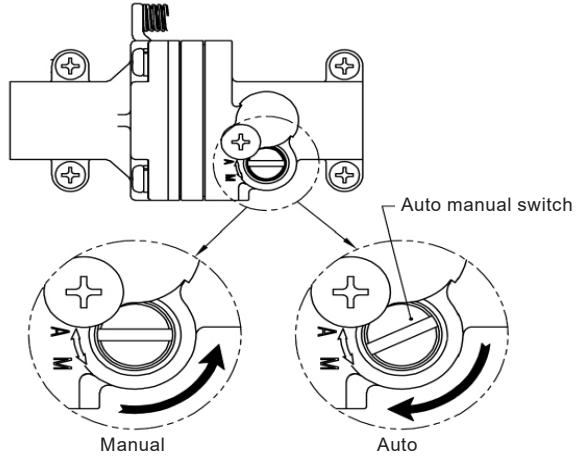

Fig. 24 A/M switch adjustment

5. Maintenance

5.1 Regular maintenance

1. Drain any build-up within the air supply filter set, as impurities such as oil, water and dirt will cause inconsistent operation.
2. Ensure air supply is at the correct pressure.
3. Make visual checks to ensure that the valve assembly is operating correctly.
4. Wipe the unit with a damp cloth or antistatic products

6. Spare parts

There are no spares for the positioner

7. Fault finding

Symptom	Remedy
Positioner does not respond to the input signal.	1) Check supply pressure level. The level must be at least 20 psi. For spring-return type of actuator, the supply pressure level has to be larger than the spring's specification.
	2) Check if input signal is properly supplied to the positioner. The signal should be 4-20mA DC.
	3) Check if zero point or span point is properly set.
	4) Check if the positioner's nozzle has been blocked. Also, check if the pressure is supplied to the positioner and pressure is being exhausted through the nozzle. If the nozzle has been blocked by any substances, please send the product for repair.
	5) Check if feedback lever has been installed properly.
The pressure of OUT1 reaches Supply pressure level and does not come back down.	1) Check Auto/Manual switch. If the switch has been damaged, please contact local Spirax Sarco office, quoting serial number.
	2) Check for a gap or damages between the nozzle and the flapper. If damaged, please contact local Spirax Sarco office, quoting serial number..
The pressure is exhausted only by Auto manual switch.	1) Check if the positioner's nozzle has been blocked. Also, check if the pressure is supplied to the positioner and the pressure is being exhausted through the nozzle. If the nozzle has been blocked by any substances, please contact local Spirax Sarco office, quoting serial number.
Hunting occurs.	1) Check if stabilizing spring has been displaced. (Next to Pilot unit)
	2) Check if there is any friction between the valve and the actuator. If so, increase actuator's size or reduce the friction level.
The actuator moves only to full open and full close positions.	1) Check if Span or Cam of the positioner is installed correctly corresponding to direct or reverse acting of the actuator. If not, refer to section 4.3 or 4.4..
Linearity is too low.	1) Check if linear positioner is properly positioned. Especially check if the feedback lever is parallel to the ground at 50% point.
	2) Check if zero and span point have been properly adjusted. If either one of values is being adjusted, another one must be re-adjusted as well.
	3) Check if supply air pressure level is stable from the regulator. If the level is unstable, the regulator must be replaced.
Hysteresis is too low.	1) In case of double acting actuator, check if seat adjustment has been properly performed. Please contact Spirax Sarco for any further inquiries regarding the seat adjustment.
	2) Backlash can occur when the feedback lever and lever spring are loose. To avoid backlash, please adjust the lever spring.
	3) Check if the feedback pin to the feedback lever is tightly fastened.