

EL3500 Series
Electric Linear Actuators
Installation and Maintenance Instructions

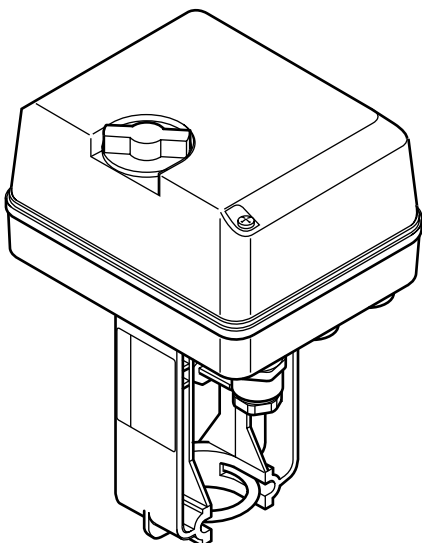

- 1. Safety information*
- 2. General*
- 3. Installation*
- 4. Commissioning*
- 5. Maintenance*

7157 484

EN1B-0195GE51 R0104

1. Safety information

See separate Installation and Maintenance Instructions for the control valve.

Your attention is drawn to Safety Information Leaflet IM-GCM-10, as well as to any National or Regional regulations.

All personnel using this product must read this manual carefully prior to operation.

If these actuators are handled improperly or not used as specified, the resultant may:

- Cause danger to the life and limb of the user or a third party.
- Damage the actuator and other assets belonging to the owner.
- Reduce the performance of the actuator.

Wiring notes

Every effort has been made during the design of the actuator to ensure the safety of the user, but the following precautions must be followed:

- i) All maintenance personnel must be suitably qualified in working with equipment containing hazardous live voltages.
- ii) Ensure correct installation. Safety may be compromised if the installation of the product is not carried out as specified in this manual.
- iii) Isolate the actuator from the mains supply before opening the unit.
- iv) The actuator is designed as an installation category II product, and is reliant on the building installation for over-current protection and primary isolation.
- v) All external circuits must meet the requirements of double insulation as stated in IEC 60364 or equivalent.
- vi) Wiring should be carried out in accordance with IEC 60364 or equivalent.
- vii) Fuse rated at 100 mA/250 V should be fitted in all phases of the actuator's supply for EL3512 spring extended (SE) or spring reserve (SR). Fuses should not be fitted in the protective earth conductor. The disconnection or removal of other equipment must not compromise the integrity of the installed protective earth system.
- viii) Spring reserve actuators have a spring engagement mechanism. As supplied this mechanism is disabled for safety reasons. To ensure that the spring reserve feature is operational refer to Section 3.6.2 for wire link details and also Section 4.1 for spring engagement procedures.
- ix) Check maximum differential pressure of the valve and actuator prior to installation.
- x) A disconnecting device (switch or circuit breaker) must be included in the building installation. This must be in close proximity to the equipment and within easy reach of the operator. The following must be observed:
 - There must be a 3 mm contact separation in all poles.
 - It must be marked as the disconnecting device for the actuator.
 - It must not interrupt the protective earth conductor.
 - It must not be incorporated into a mains supply cord.
 - The requirements for the disconnecting device are specified in IEC 60947-1 and IEC 60947-3 or equivalent.
- xi) The Actuator must not be located in such a way that the disconnecting device is made difficult to operate.

Safety requirements and electromagnetic compatibility

This product is CE marked. It complies with the requirements of 73/23/EEC as amended by 93/68/EEC on the harmonisation of the law of Member States relating to electrical equipment designed for use within certain voltage limits (LVD), by meeting the standard for safety of automatic electrical controls for household and similar use.

Warning:

This product complies with the requirement of 89/336/EEC as amended by 92/31/EEC and 93/68/EEC on the approximation of the laws of the Member States relating to Electromagnetic Compatibility, by meeting the standards of generic standard of emissions for a residential, commercial and light industrial environment and the generic standard of immunity for an industrial environment.

This product may be exposed to interference above the limits of industrial immunity if:

- The product or its wiring is located near a radio transmitter.
- Excessive electrical noise occurs on the mains supply.

Cellular telephones and mobile radios may cause interference if used within approximately three meters of the product or its wiring. The actual separation necessary will vary according to the power of the transmitter.

Power line protectors (ac) should be installed if mains supply noise is likely. Protectors can combine filtering, suppression, surge and spike arrestors.

For a copy of the declaration of conformity contact Spirax Sarco.

Warning:

If this product is not used in the manner specified by this IMI, then the protection provided may be impaired.

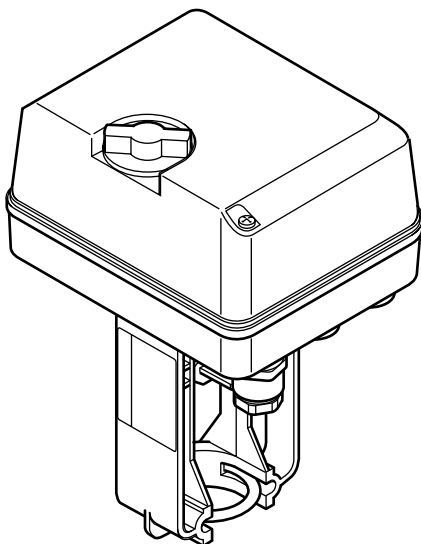

Fig. 1

2. General

2.1 Use

EL3500 series electric linear actuators are for use with KE and LE two port valves (DN15 to 50), Self-acting valves (BX, SB, KA, KB, KC and NS) and TW three port valves.

This range offers actuators for on/off control, modulating control with external valve motor drive switches and modulating control with 0-10 or 2-10 Vdc input signal.

See the appropriate Technical Information Sheet for full performance details.

EL3500 series actuators are designed to travel 20 mm and are available with spring reserve as an option, operating with voltages of 24 Vac and 230 Vac. One 24 Vac model is available with 0-10 or 2-10 Vdc (4-20 mA if a 500 Ω resistor is fitted) control signal for modulating applications. One 24 Vac model is available with spring retract capability. Full details of the types and reference numbers are given in Table 1 below.

Table 1 EL3500 actuator range

Electric	Series	Control	Voltage	Spring reserve
EL	35	0 = VMD	1 = 230 Vac	SE = Spring Extend
		1 = 0/2 - 10 V	2 = 24 Vac	SR = Spring Retract

Note: 0/2-10 V modulating actuators are only available in 24 Vac voltages. The SR model is only available as EL3512SR.

Selection example: 1 off Spirax Sarco EL3501SE actuator with VMD control operated by a voltage of 230 Vac. On power failure the actuator will extend.

2.2 Operation

The drive of a synchronous motor is converted into linear motion of the actuator by using spur gear transmission. An integrated spring package limits the stem force to a 600 N thrust in both directions. The installed torque switch automatically switches the actuator motor off when this force is reached. All EL3500 actuators are designed to travel 20 mm.

2.3 Manual operation

Applicable to non-spring reserve actuators (EL3501, EL3502 and EL3512) only. Ensure the power supply to the actuator is isolated. The handwheel can be used in power fail situations or during installation work such as mounting the actuator to the valve.

For spring reserve models SE or SR the handwheel can be found under the lid. (See Figure 31 in Section 4.1)

Depressing the handwheel (X) and turning in the desired direction (Y) will move the stem (Z) (see Fig. 2 below).

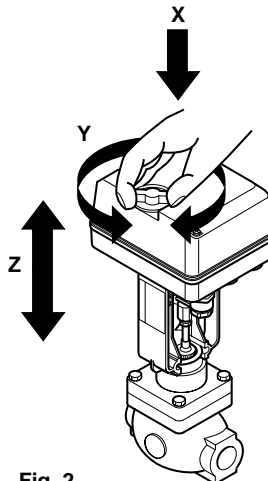

Fig. 2

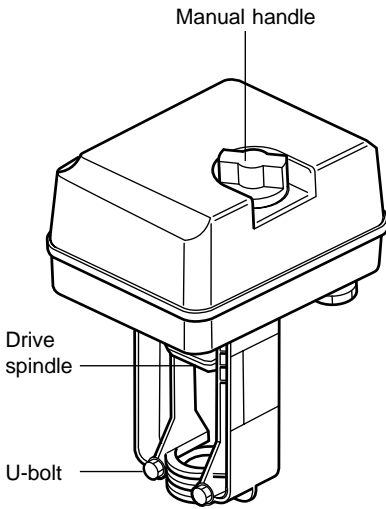

Fig. 3 EL3501, EL3502 and EL3512

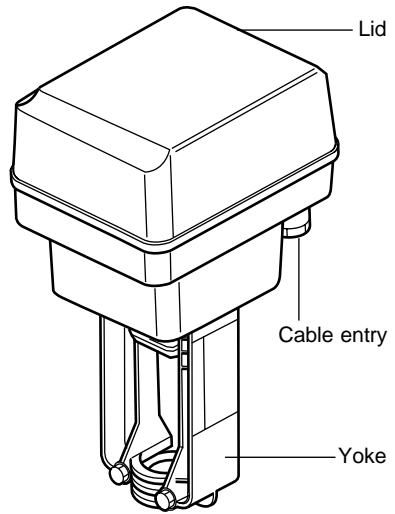

Fig. 4 EL3501SE, EL3502SE, EL3512SE and EL3512SR

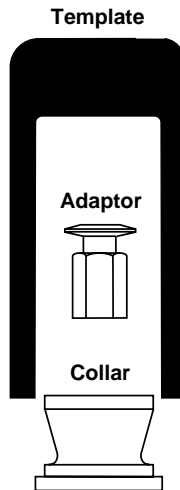

Fig. 5
LE and KE linkage kit included with the actuator.
Compromising of collar, adaptor and cardboard template.

3. Installation

3.1 Location

The actuator should be mounted above the valve with sufficient space to remove the cover and general ease of access. When selecting a location, make sure that the actuator is not exposed to ambient conditions exceeding the range -10°C to $+50^{\circ}\text{C}$ at 5 to 95% RH. If necessary, provide insulation to prevent overheating. The actuator is rated at IP54, but only when the lid is fitted correctly and the cable gland entries are tightened against the cables.

3.1.1 Orientation and pipeline flow temperatures

The Valve and actuator may be rotated from vertical. The allowable positions depend upon the pipeline temperature (see Figs 6, 7 and 8)

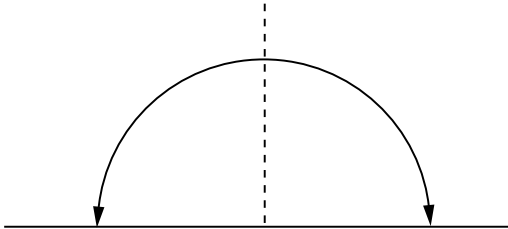

Fig. 6 Up to $+150^{\circ}\text{C}$ with standard kit

This is the standard application and does not require the EL3905 high temperature kit. The orientation of the valve **must** be between 0° and 90° from vertical.

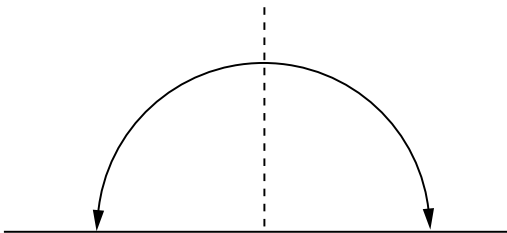

Fig. 7 150°C to 220°C with EL3905 high temperature kit

For this temperature range the EL3905 high temperature kit **must** be used. The orientation of the valve **must** be between 0° and 90° from vertical.

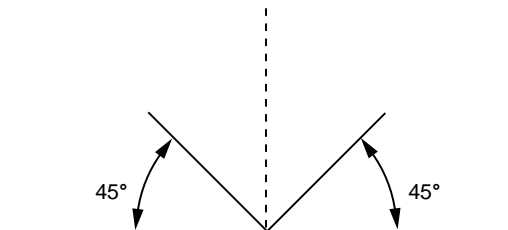

Fig. 8 220°C to 250°C with EL3905 high temperature kit

For this temperature range the EL3905 high temperature kit **must** be used and the valve **must** not be mounted vertically. The orientation should be between 45° and 90° from vertical.

3.2 Fitting the valve linkage

Normally the EL3500 actuator will be supplied fitted to the valve. However should it be necessary to fit an actuator, the following procedure should be adopted:



When mounting an actuator on to a valve, never drive the actuator electrically instead use the handwheel. It should not be necessary to adjust the actuator, as it will be supplied at mid position.

3.2.1 Fitting valve linkage to KE and LE valves

Using the linkage kit EL3904 supplied. For KE and LE valves the split collar (A) should be screwed onto the valve bonnet and hand tightened as shown in Fig. 9.

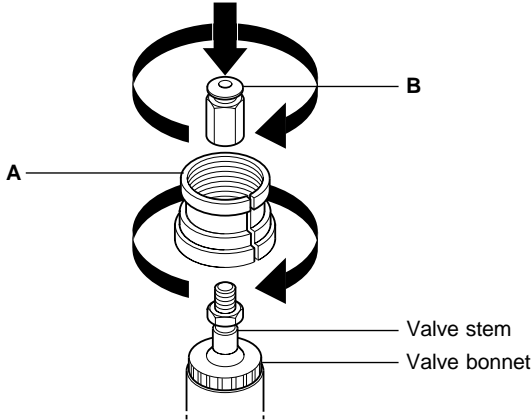

Fig. 9

Ensure the valve stem is pushed down to fully close the valve. Screw the adaptor (B) onto the valve stem. Using the cardboard template (D, provided with the product) adjust the height of the valve linkage to achieve a stand-out height of 89 ± 0.5 mm. Secure the valve linkage at this position by tightening the lock-nut (C).

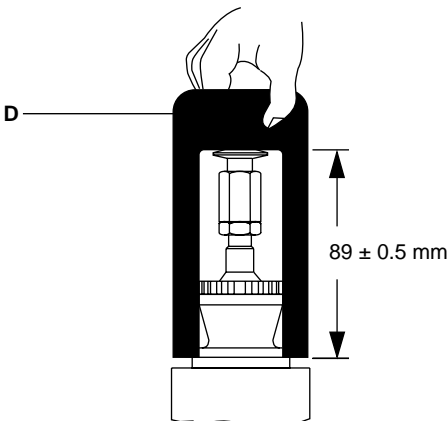

Fig. 10

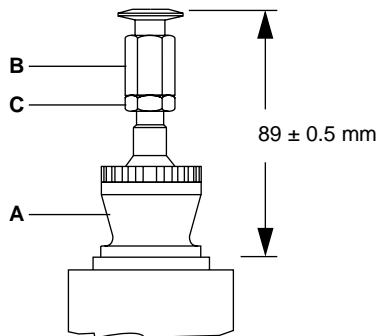

Fig. 11

3.2.2 Fitting valve linkage to self-acting valves

For Self-acting valves firstly attach the linkage kit EL3808 or EL3809 to the valve bonnet (A) as shown in Fig. 12.

Adjust the position of the valve linkage (B) to achieve a stand-out height of 78 ± 0.5 mm. Secure the valve linkage at this position by tightening the lock-nut (C).

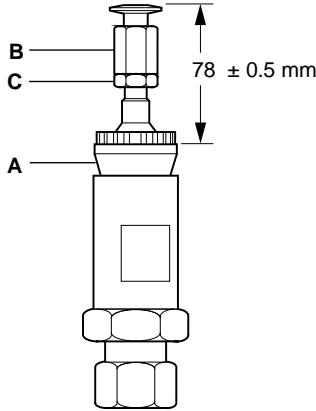

Fig. 12

3.3 Fitting the actuator to the valve

Loosen the U-bolt securing nuts (D) and locate the actuator onto the shoulder of the collar. Push the spring loaded plate (E) and pull the valve spindle up to engage into the plate. Releasing the plate will lock the valve and actuator together. Tighten the U-bolt nuts (D) to a torque of 4 N m. See Fig. 13.

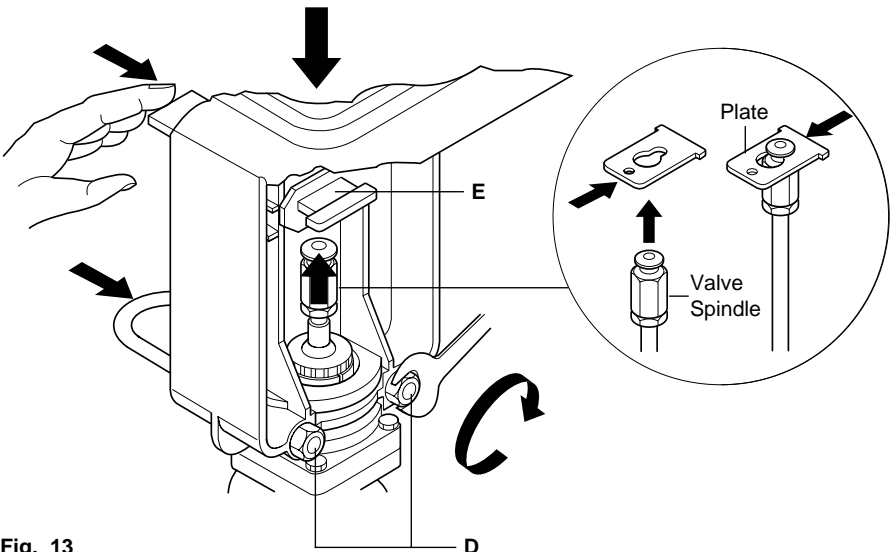

Fig. 13

3.4 Removing and refitting the actuator cover



Ensure the power is disconnected before removing the cover.

To remove the actuator cover, loosen the two retaining screws and lift the lid clear. When refitting the cover be careful not to over tighten the retaining screws. Note the handwheel is retained in the lid.

3.5 Fitting the accessories

Should it be necessary to fit any accessories, the following procedures should be adopted.

Options

EL3901	Auxiliary potentiometer	10 k ohms
EL3902	Auxiliary potentiometer	220 ohms
EL3903	Auxiliary switches	
EL3905	High temperature kit	

3.5.1 Fitting the auxiliary potentiometers (EL3901, EL3902)

1. The potentiometer (F) should be rotated fully clockwise using a flat screwdriver on the end of the potentiometer shaft.
2. Ensure the actuator is fully extended against the valve seat.
3. Locate and screw the potentiometer in place as shown in Fig. 14.
4. A terminal block (G) and label (H) are also supplied and should be screwed to the base.
5. The Pg 11 cable gland will need to be screwed into the actuator case after the 'knockout' disc is removed.
6. Connect the potentiometer cables following the wiring diagram shown in Fig. 14.
Note: The cables must be neatly retained as shown. This will prevent them being snagged on the drive spindle.
7. Fully retract the actuator noting the resistance. Fully extend the actuator and ensure the resistance change covers the full actuator stroke.

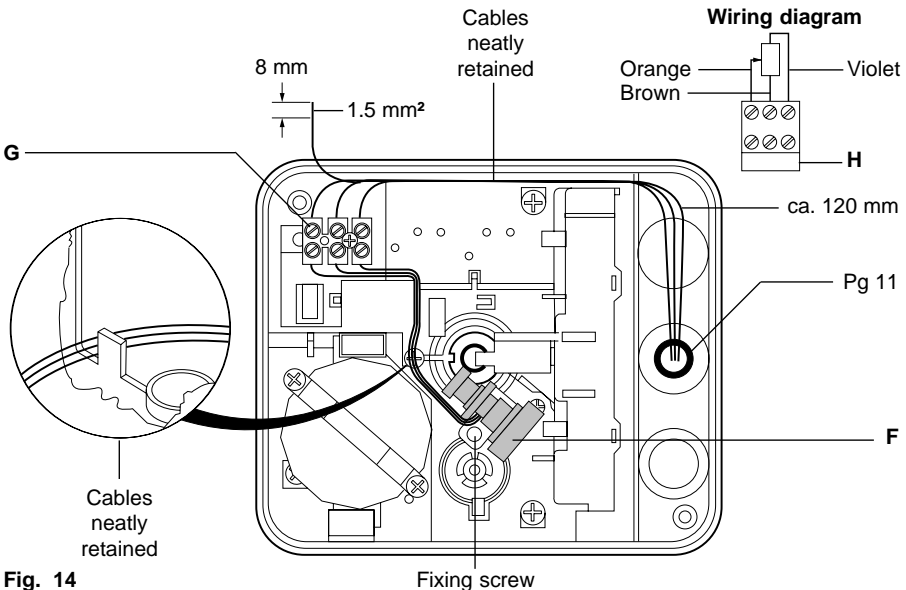

Fig. 14

3.5.2 Fitting the auxiliary switches (EL3903)

Note: If an auxiliary potentiometer is to be fitted ensure this is done before the auxiliary switches are connected.

1. Using the two lugs on the bottom of the switch assembly (J) locate it on the actuator base panel. See Fig. 15.
2. Press the top of the switch assembly to clip it underneath the base bracket (K).
3. A terminal block (L) and label (M) are also supplied and should be screwed to the base.
4. The Pg 13.5 cable gland will need to be screwed into the actuator case after the 'knock-out' disc is removed.
5. Connect the cables following the wiring diagram shown in Fig. 15. **Note:** The cables must be neatly retained to prevent them being damaged when fitting the lid or snagging on the switch assembly.
6. The switching positions are adjusted by loosening the switch cams (N) and repositioning them.

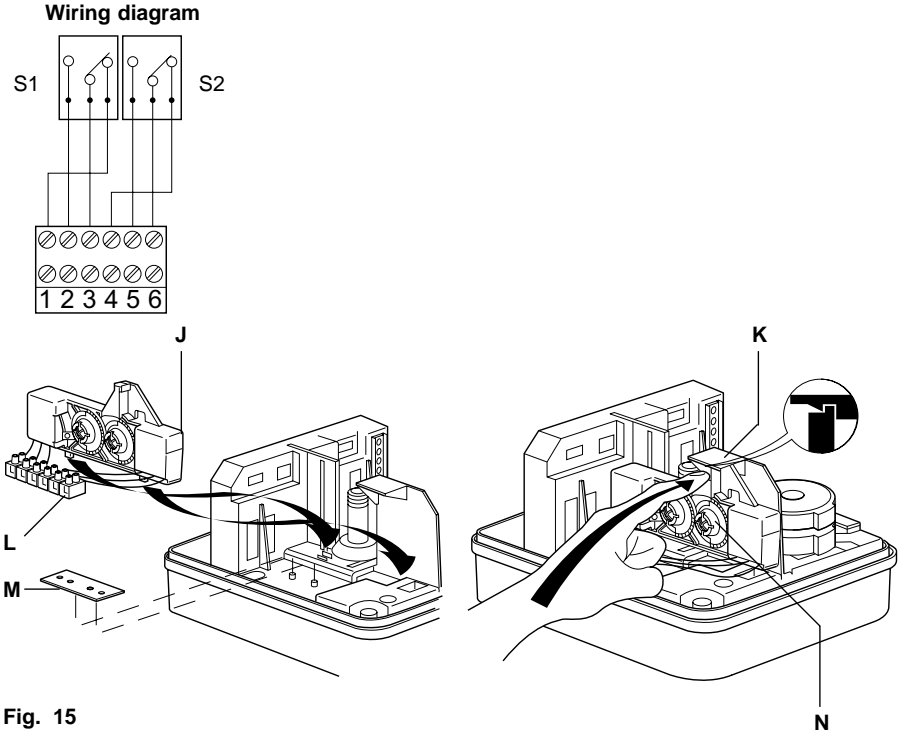

Fig. 15

3.5.3 Fitting the high temperature kit to LE and KE valves (EL3905)

1. Ensure the threaded split collar (A) is screwed onto the valve and hand tightened onto the shoulder.
2. Place extension yoke (O) over the split collar and tighten both set screws (D).
3. Screw the valve linkage (B) onto the extension piece (P) and tighten together.
4. Screw the extended linkage piece onto the valve stem and using the cardboard template (provided with the product) adjust the position of the valve linkage to achieve a stand-out height of 89 ± 0.5 mm. Secure the extended valve linkage at this position by tightening the lock-nut on the valve stem.

Assemble the actuator to the extension using the method described in Section 3.3.

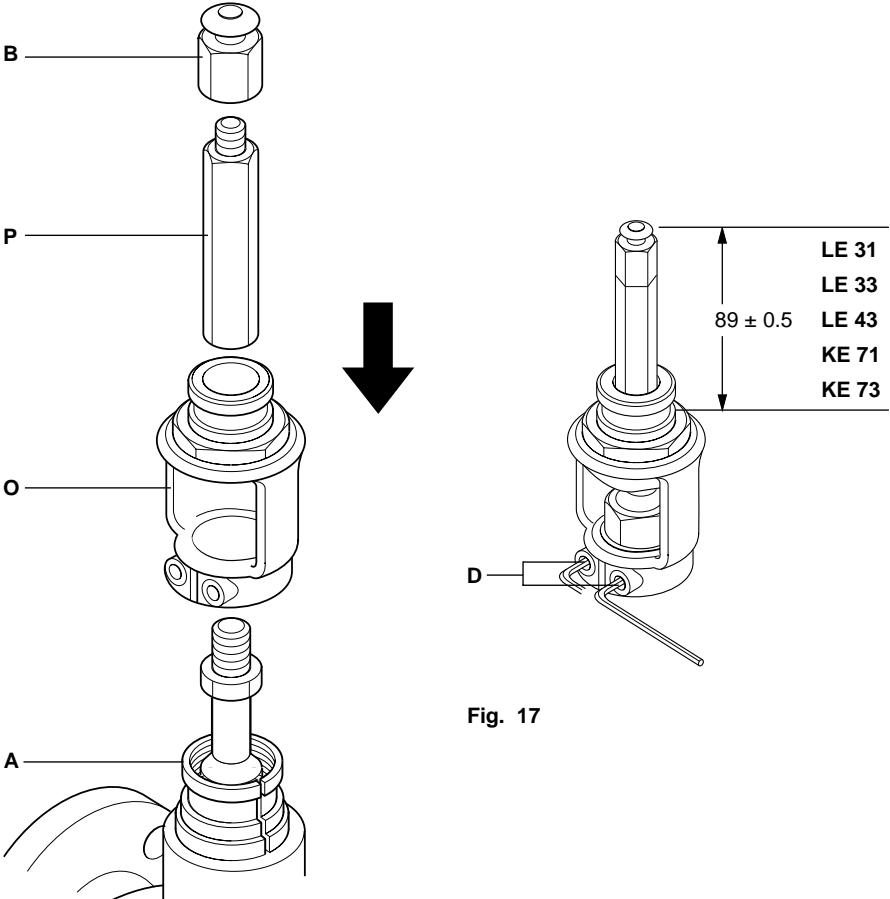

Fig. 17

Fig. 16

3.6 Wiring details



Connection to the mains supply is important.

Important

1. Read 'Safety Information, Wiring Notes' (Section 1), before attempting to wire the supply to the actuator.
2. Slow blow fuses should be fitted in all phases, but not in the protective earth conductor.
3. The protective earth terminal must be connected to the installation protective earth system. Disconnection or removal of other equipment must not compromise the integrity of the installation protective earth system.
4. For supply connections, use 1.5 mm² wire, double insulated as stated in IEC 60364 (or equivalent), if wires are exposed to touch.

3.6.1 Terminal connections

Ensure the correct tools and wire gauge is used. See Fig. 18.

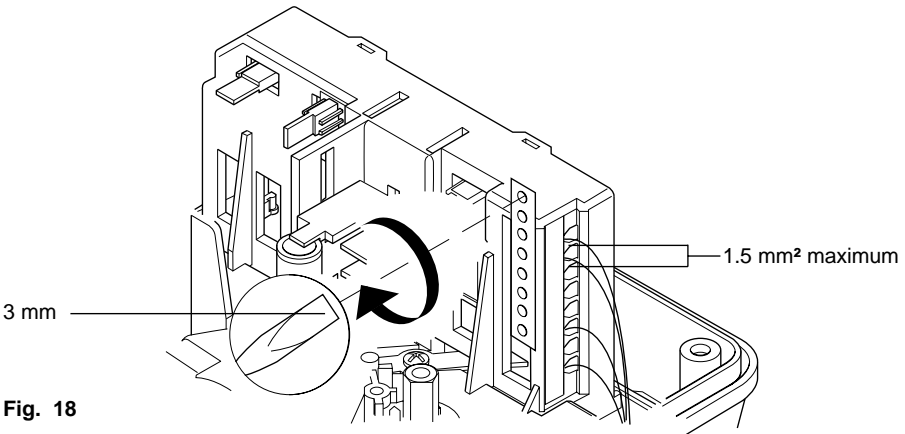

Fig. 18

3.6.2 Connection for VMD actuators (EL3501, EL3502, EL3501SE and EL3502SE)

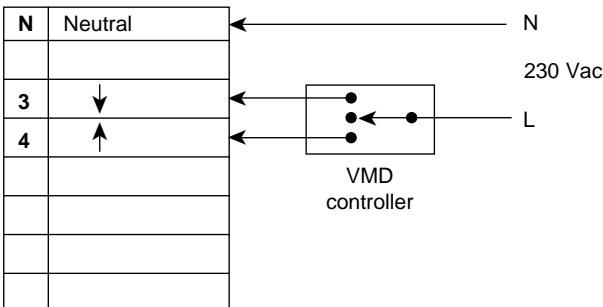

Fig. 19 EL3501

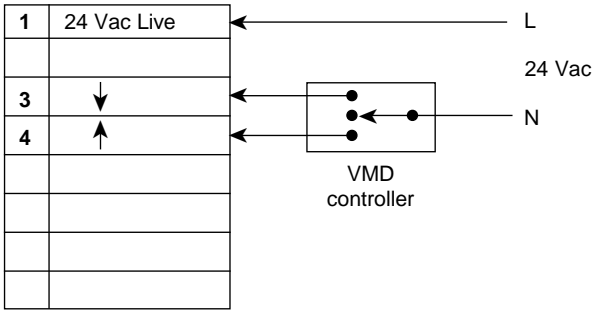

Fig. 20 EL3502

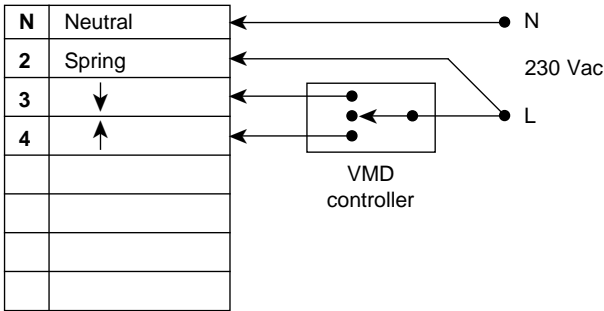

Fig. 21 EL3501SE

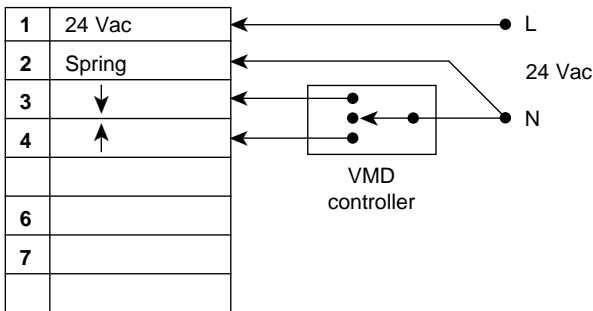

Fig. 22 EL3502SE

3.6.3 Connection for positioning actuators (EL3512, EL3512SE and EL3512SR)

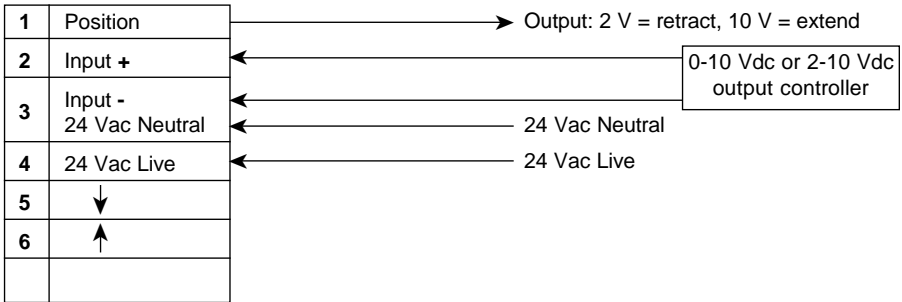

Fig. 23 EL3512 0-10 Vdc or 2-10 Vdc input

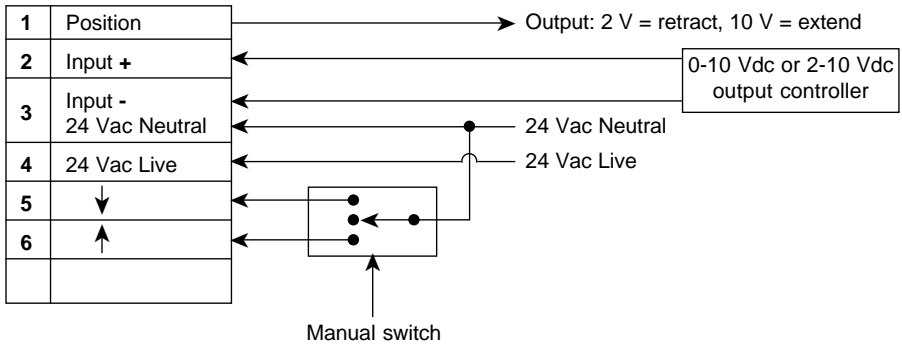

Fig. 24 EL3512 0-10 Vdc or 2-10 Vdc input with manual switch

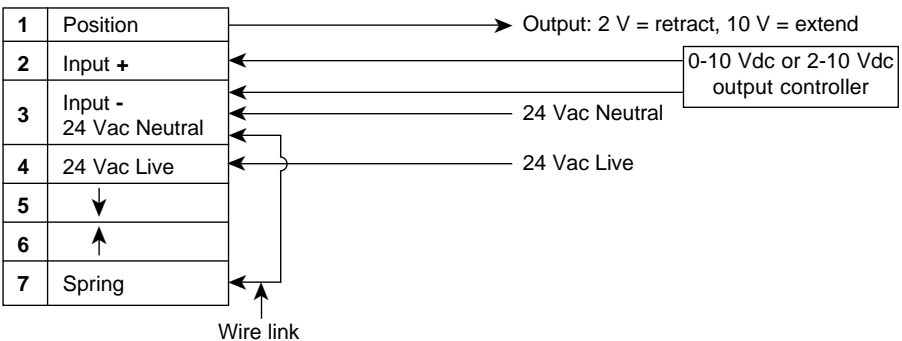

Fig. 25 EL3512SE or EL3512SR 0-10 Vdc or 2-10 Vdc input

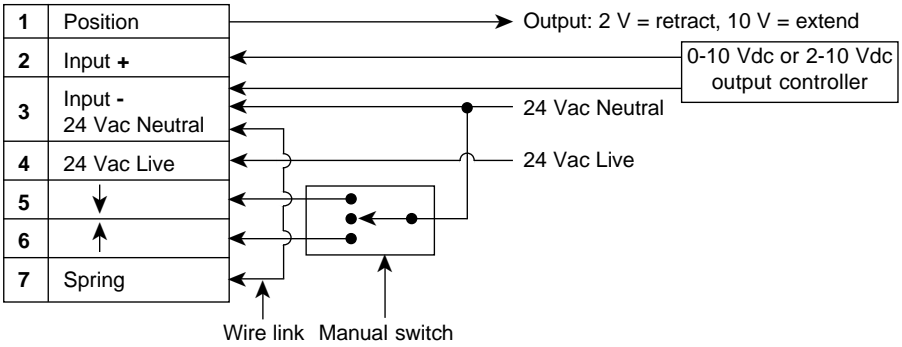
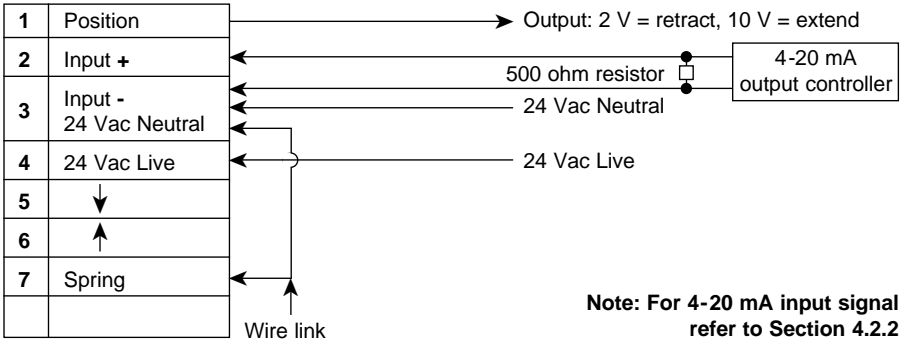
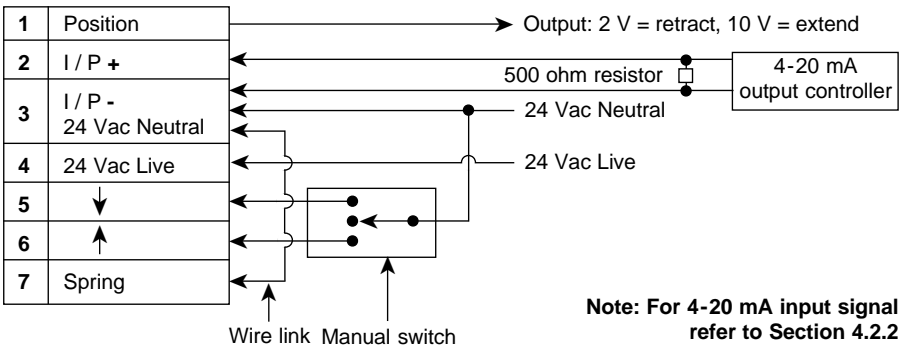

Fig. 26 EL3512SE or EL3512SR 0-10 Vdc or 2-10 Vdc input with manual switch



Note: For 4-20 mA input signal refer to Section 4.2.2

Fig. 27 EL3512SE or EL3512SR 4-20 mA input



Note: For 4-20 mA input signal refer to Section 4.2.2

Fig. 28 EL3512SE or EL3512SR 4-20 mA input with manual switch

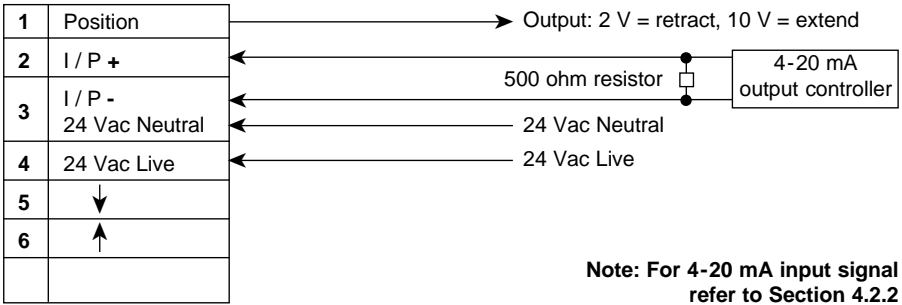

Fig. 29 EL3512 4-20 mA input

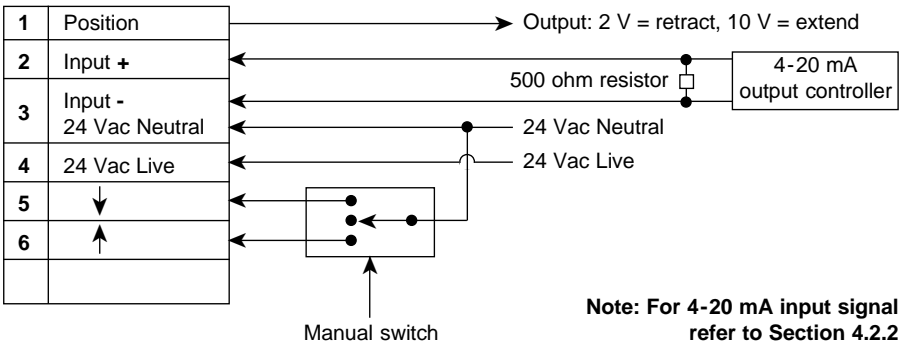

Fig. 30 EL3512 4-20 mA input with manual switch

3.7 Manual switch (EL3512, EL3512SE and EL3512SR)

This is an auxiliary method of overriding the actuator position. An external switch (single pole change over) can be connected to provide a manual method of driving the actuator. See Figs. 24, 26, 28 and 30.

3.8 Spring reserve wiring

For the spring reserve models below, an extra wire terminal called 'spring' is included.

EL3512SE, EL3512SR: a wire link must be fitted across terminal 3 (Neutral) and 7 (spring).

EL3501SE: the Live 230 Vac must be wired to terminal 2 (spring).

EL3502SE: the Neutral 24 Vac must be wired to terminal 2 (spring).

Ensure this terminal is wired correctly. If this connection is not made, the spring reserve will be engaged against the drive shaft and the motor will be disabled.

This is a special safety function for these models. For example, an emergency shut switch could be wired before the 'spring' terminal. This can be used to break the connection to the 'spring' terminal to activate the spring reserve for driving the actuator closed (SE) or open (SR) in an emergency.

NOTE: The spring reserve is a safety feature and should only be used for emergencies.

4. Commissioning

This actuator requires **no** setting of limit switches or potentiometers. With the correct setting of the linkage height (as described in Section 3.2.1) the 20 mm travel is automatically set. Complete the appropriate sections relative to the actuator being commissioned.

4.1 Engaging the spring reserve mechanism for SE and SR versions



For SE and SR versions the spring mechanism **MUST** be engaged prior to use.

Isolate the electrical power from the actuator. Remove the actuator cover. Caution must be taken when releasing the spring handle due to spring recoil.

Remove the locking piece (**R**) Fig. 31 and pull the spring handle (**Q**) upwards and release (see Fig. 32). Retain the locking piece for further use.

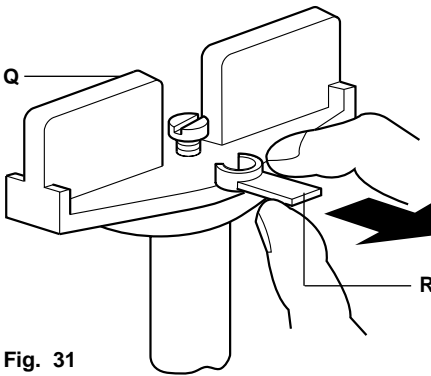

Fig. 31

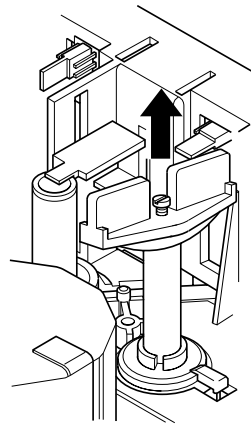

Fig. 32

The spring handle will recoil clockwise with spring extend (SE) actuators or anticlockwise for spring retract (SR) actuators (see Fig. 33).

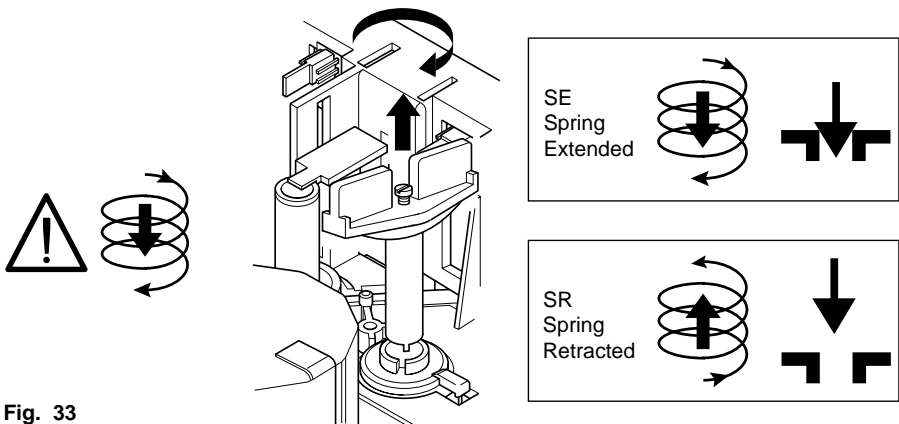

Fig. 33

4.2 Setting jumper switches for positioning actuators EL3512, EL3512SE and EL3512SR

These actuators have three jumper switches:-

W1 = Signal failure position

W2 = Input signal range

W3 = Reverse or direct acting

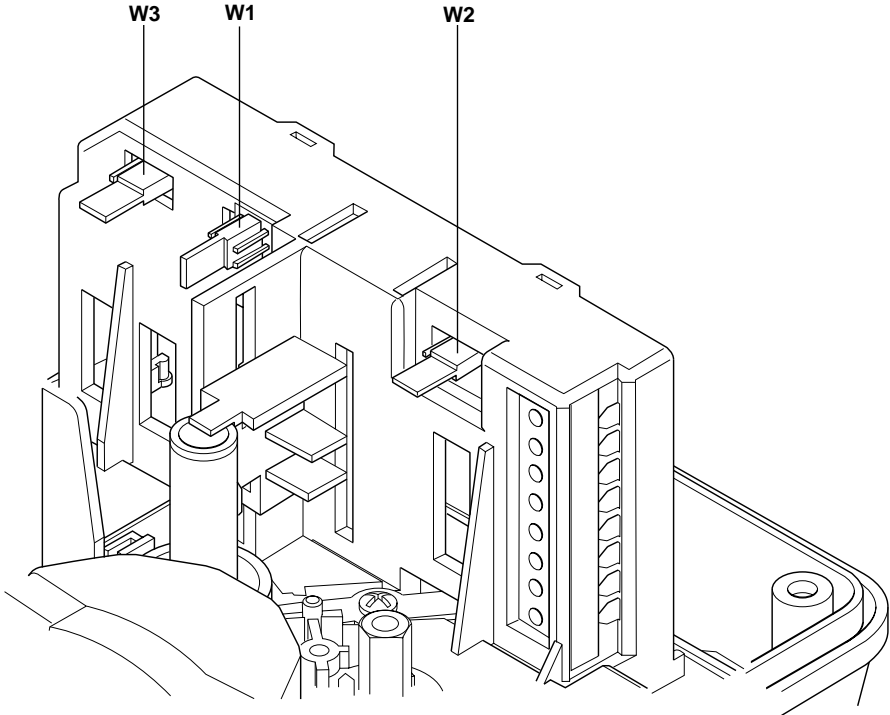

Fig. 34

4.2.1 Setting the W1 jumper switch (signal failure position, Fig. 35)

If the control signal is lost due to the cable being severed or disconnected the actuator will detect this open circuit. If this happens the actuator can move to one of three positions:-

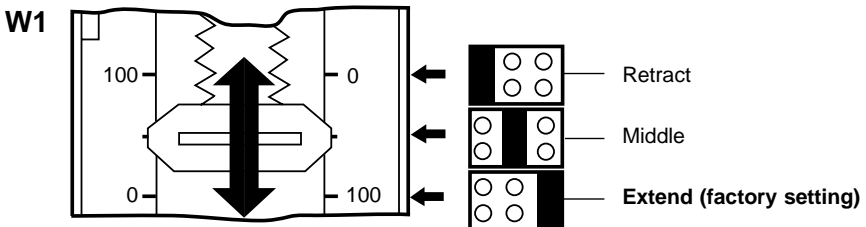

Fig. 35

4.2.2 Setting the W2 jumper switch (input signal range, Fig. 36)

The input signal range can be set as 2-10 Vdc or 0-10 Vdc.

Important:- If using a 4-20 mA input signal as described in Section 3.6 **W2** must be set to 2-10 Vdc.

4.2.3 Setting the W3 jumper switch (reverse or direct acting, Fig. 37)

W3 sets the direction the actuator travels when the input signal is increased towards 10 V. The options are to extend the actuator or retract (factory setting) the actuator with a 10 Vdc signal.

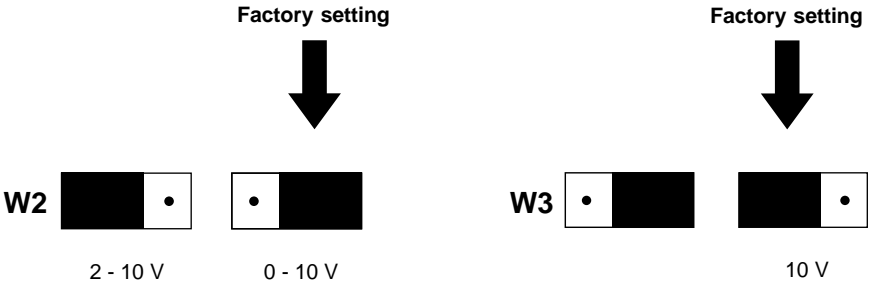

Fig. 36 Setting input signal range.



Fig. 37 Setting reverse or direct acting.

5. Maintenance



Always make sure that the electrical supply is switched off when carrying out maintenance on the actuator or valve.

5.1 Removing the actuator

To remove the standard actuator (without spring reserve) following the steps in section 3.3 in reverse order.

For spring reserve actuators follow steps:-

1. Isolate the electrical power supply.
2. Remove the actuator cover.
3. Disconnect the wiring and pull it clear of the actuator.
4. Rotate the spring handle **Q** (Fig. 31) to achieve the middle position of the actuator travel.
Note: the spring force will be acting on the spring handle. Care must be taken when rotating the handle
5. With the actuator travel in the middle position push the handle down to lock it in place.
6. When the handle is locked in place insert the locking piece **R** to secure the handle.
7. Loosen the U-bolt clamp nuts.
8. Push the spring-loaded plate to the centre and release the actuator from the valve.

