

DCV6

Disc Check Valve

Installation and Maintenance Instructions

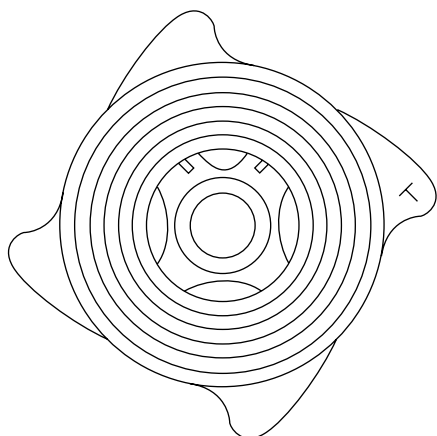

1. *Safety information*
2. *General product information*
3. *Installation*
4. *Commissioning*
5. *Operation*
6. *Maintenance*
7. *Spare parts*

1. Safety information

Safe operation of this product can only be guaranteed if it is properly installed, commissioned, used and maintained by qualified personnel (see Section 1.11) in compliance with the operating instructions. General installation and safety instructions for pipeline and plant construction, as well as the proper use of tools and safety equipment must also be complied with.

1.1 Intended use

Referring to the Installation and Maintenance Instructions, name-plate and Technical Information Sheet, check that the product is suitable for the intended use/application. The product listed below complies with the requirements of the European Pressure Equipment Directive 97/23/EC and carries the CE mark when so required. The product falls within the following Pressure Equipment Directive categories:

	Product	Group 1 Gases	Group 2 Gases	Group 1 Liquids	Group 2 Liquids
DCV6	DN15 - DN25	SEP	SEP	SEP	SEP
	DN32	2	SEP	SEP	SEP
	DN40 - DN50	2	1	SEP	SEP
	DN65 - DN80	2	1	2	SEP
	DN100	2	1	2	SEP

- i) The DCV6 has been specifically designed for use on propane or methane gases which are in Group 1 of the above mentioned Pressure Equipment Directive. They can also be used on steam, air or water / condensate which are in Group 2 of the Pressure Equipment Directive. The products' use on other fluids may be possible but, if this is contemplated, Spirax Sarco should be contacted to confirm the suitability of the product for the application being considered.
- ii) Check material suitability, pressure and temperature and their maximum and minimum values. If the maximum operating limits of the product are lower than those of the system in which it is being fitted, or if malfunction of the product could result in a dangerous overpressure or overtemperature occurrence, ensure a safety device is included in the system to prevent such over-limit situations.
- iii) Determine the correct installation situation and direction of fluid flow.
- iv) Spirax Sarco products are not intended to withstand external stresses that may be induced by any system to which they are fitted. It is the responsibility of the installer to consider these stresses and take adequate precautions to minimise them.
- v) Remove protection covers from all connections and protective film from all name-plates, where appropriate, before installation on steam or other high temperature applications.

1.2 Access

Ensure safe access and if necessary a safe working platform (suitably guarded) before attempting to work on the product. Arrange suitable lifting gear if required.

1.3 Lighting

Ensure adequate lighting, particularly where detailed or intricate work is required.

1.4 Hazardous liquids or gases in the pipeline

Consider what is in the pipeline or what may have been in the pipeline at some previous time. Consider: flammable materials, substances hazardous to health, extremes of temperature.

1.5 Hazardous environment around the product

Consider: explosion risk areas, lack of oxygen (e.g. tanks, pits), dangerous gases, extremes of temperature, hot surfaces, fire hazard (e.g. during welding), excessive noise, moving machinery.

1.6 The system

Consider the effect on the complete system of the work proposed. Will any proposed action (e.g. closing isolation valves, electrical isolation) put any other part of the system or any personnel at risk?

Dangers might include isolation of vents or protective devices or the rendering ineffective of controls or alarms. Ensure isolation valves are turned on and off in a gradual way to avoid system shocks.

1.7 Pressure systems

Ensure that any pressure is isolated and safely vented to atmospheric pressure. Consider double isolation (double block and bleed) and the locking or labelling of closed valves. Do not assume that the system has depressurised even when the pressure gauge indicates zero.

1.8 Temperature

Allow time for temperature to normalise after isolation to avoid danger of burns and consider whether protective clothing (including safety glasses) are required.

Viton seat:

If the Viton seat has been subjected to a temperature approaching 315°C (599°F) or higher it may have decomposed and formed hydrofluoric acid. Avoid skin contact and inhalation of any fumes as the acid will cause deep skin burns and damage the respiratory system.

1.9 Tools and consumables

Before starting work ensure that you have suitable tools and/or consumables available. Use only genuine Spirax Sarco replacement parts.

1.10 Protective clothing

Consider whether you and/or others in the vicinity require any protective clothing to protect against the hazards of, for example, chemicals, high/low temperature, radiation, noise, falling objects, and dangers to eyes and face.

1.11 Permits to work

All work must be carried out or be supervised by a suitably competent person. Installation and operating personnel should be trained in the correct use of the product according to the Installation and Maintenance Instructions.

Where a formal 'permit to work' system is in force it must be complied with. Where there is no such system, it is recommended that a responsible person should know what work is going on and, where necessary, arrange to have an assistant whose primary responsibility is safety.

Post 'warning notices' if necessary.

1.12 Handling

Manual handling of large and/or heavy products may present a risk of injury. Lifting, pushing, pulling, carrying or supporting a load by bodily force can cause injury particularly to the back. You are advised to assess the risks taking into account the task, the individual, the load and the working environment and use the appropriate handling method depending on the circumstances of the work being done.

1.13 Residual hazards

In normal use the external surface of the product may be very hot. If used at the maximum permitted operating conditions the surface temperature of some products may reach temperatures of 400°C (752°F).

Many products are not self-draining. Take due care when dismantling or removing the product from an installation (refer to 'Maintenance instructions').

1.14 Freezing

Provision must be made to protect products which are not self-draining against frost damage in environments where they may be exposed to temperatures below freezing point.

1.15 Disposal

Unless otherwise stated in the Installation and Maintenance Instructions, this product is recyclable and no ecological hazard is anticipated with its disposal providing due care is taken. However, if the valve is fitted with a Viton seat, special care must be taken to avoid potential health hazards associated with decomposition/burning of these seats.

Viton:

- Can be landfilled, when in compliance with National and Local regulations
- Can be incinerated, when in compliance to National and Local regulations but a scrubber must be used to remove Hydrogen Fluoride, which is evolved from the product.
- Is insoluble in aquatic media.

1.16 Returning products

Customers and stockists are reminded that under EC Health, Safety and Environment Law, when returning products to Spirax Sarco they must provide information on any hazards and the precautions to be taken due to contamination residues or mechanical damage which may present a health, safety or environmental risk. This information must be provided in writing including Health and Safety data sheets relating to any substances identified as hazardous or potentially hazardous.

— 2. General product information —

2.1 General description

The DCV6 stainless steel disc check valve is of the wafer pattern designed to be sandwiched between flanges. It is suitable for use on a wide range of fluids for applications in process lines, hot water systems, steam and condensate lines etc. They have an increased gasket face area compared to the DCV3, with face-to-face dimensions conforming to EN 558 part 2, series 52.

As standard it will be supplied with a metal-to-metal seat for use on steam applications. Where it is being used on oil, air, gas and water applications, alternative seat material is available - see 'Optional extras'.

Note: Wafer check valves are not suitable for use where heavily pulsating flow exists, such as close to a compressor.

Optional extras

Heavy duty springs (700 mbar opening pressure, up to DN65) for boiler feed applications.

High temperature springs for temperatures up to 400°C (752°F).

Viton soft seats for oil, gas and air applications.

EPDM soft seats for water applications.

Standards

This product fully complies with the requirements of the European Pressure Equipment Directive 97/23/EC.

Standard shut-off

Standard valves conform to DIN 3230 part 3, BO3.

Soft seated versions meet DIN 3230 part 3, BN1 and BO1 provided a differential pressure exists.

Certification

This product is available with certification to EN 10204 3.1. **Note:** All certification/inspection requirements must be stated at the time of order placement.

Note: For further product data see the Technical Information sheet TI-P134-26.

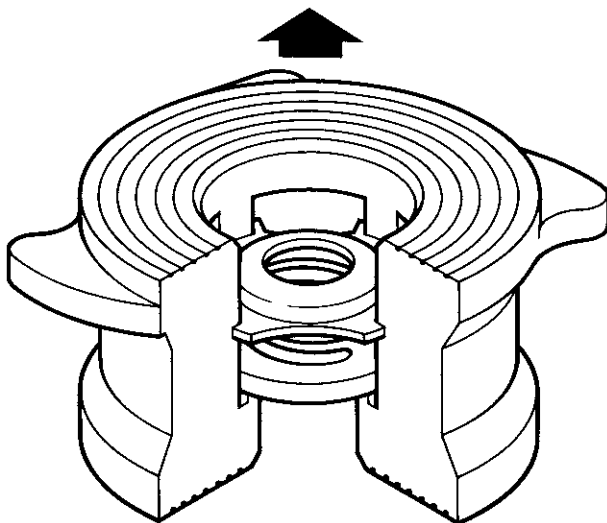

Fig. 1

2.2 Sizes and pipe connections

DN15, DN20, DN25, DN32, DN40, DN50, DN65, DN80 and DN100

Suitable for installation between the following flanges:

EN 1092 PN10, PN16, PN25 and PN40,

JIS 10K, JIS 16K, JIS 20K, JIS 30K and JIS 40K,

KS 10K, KS 16K, KS 20K, KS 30K and KS 40K,

ASME (ANSI) B 16.5 Class 150 and Class 300

Note: DN80 and DN100 - will not fit between JIS 10K.

Flange face options: Flange faces may be machined to fit between flanges according to: DIN 2512, 2513, 2514 and ASME (ANSI) 150/300 RJ.

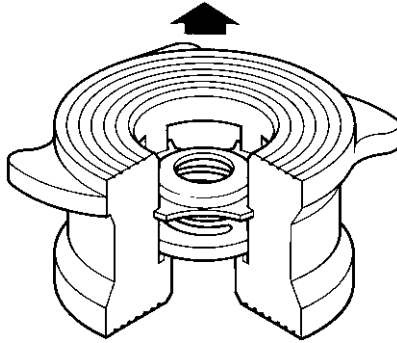

Fig. 2

2.3 Materials

Part	Material
Body	Austenitic stainless steel
Disc	Austenitic stainless steel
Spring retainer	Austenitic stainless steel
Standard spring	Austenitic stainless steel
Heavy duty spring	Austenitic stainless steel
High temperature spring	Nickel alloy

2.4 Seating options

The valves are stamped to identify the internals fitted:

'N'	- High temperature spring	- Standard metal disc
'W'	- Without spring	- Standard metal disc
'H'	- Heavy duty spring	- Standard metal disc
'V'	- Standard spring	- Viton soft faced disc
'E'	- Standard spring	- EPDM soft faced disc
'WV'	- Without spring	- Viton soft faced disc
'WE'	- Without spring	- EPDM soft faced disc
'HV'	- Heavy duty spring	- Viton soft faced disc
'HE'	- Heavy duty spring	- EPDM soft faced disc
'T'	- Valves tested to DIN 3230 part 3, B03	

No identification indicates a standard spring with a metal disc.

2.5 Pressure / temperature limits

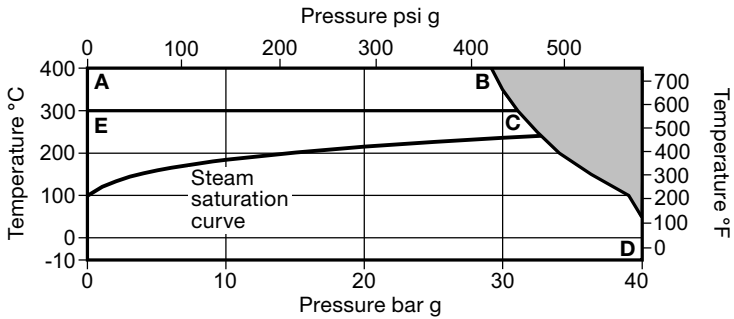

 The product **must not** be used in this region.

A - B - D High temperature spring and without spring.

E - C - D Standard spring and heavy duty spring.

Please note: The figures displayed are only relevant when a metal-to-metal seat is used. If Viton or EPDM seats are used the product is restricted to the limits of the seat material chosen.

Body design conditions for saturated steam service		PN40 and ANSI 300	
PMA	Maximum allowable pressure	40 bar g @ 50°C	(580 psi g @ 122°F)
TMA	Maximum allowable temperature	400°C @ 29.2 bar g	(752°F @ 423.5 psi g)
	Minimum allowable temperature	-10°C	(14°F)
PMO	Maximum operating pressure for saturated steam service	40 bar g @ 50°C	(580 psi g @ 122°F)
	Standard spring	300°C @ 33.3 bar g	(572°F @ 483 psi g)
	Heavy duty spring	300°C @ 33.3 bar g	(572°F @ 483 psi g)
TMO	Maximum operating temperature	High temperature spring	400°C @ 31.2 bar g (752°F @ 452 psi g)
		Without spring	400°C @ 31.2 bar g (752°F @ 452 psi g)
	Minimum operating temperature	-10°C	(14°F)
Note: For lower operating temperatures consult Spirax Sarco			
Temperature limits	Viton seat	-10°C to +250°C	(14°F to +482°F)
	EPDM seat	-10°C to +150°C	(14°F to +302°F)
Designed for a maximum cold hydraulic test pressure of:		76 bar g	(1 102 psi g)

3. Installation

Note: Before actioning any installation observe the 'Safety information' in Section 1.

Referring to the Installation and Maintenance Instructions, name-plate and Technical Information Sheet, check that the product is suitable for the intended installation:

- 3.1** Check materials, pressure and temperature and their maximum values. If the maximum operating limit of the product is lower than that of the system in which it is being fitted, ensure that a safety device is included in the system to prevent overpressurisation.
- 3.2** Determine the correct installation situation and the direction of fluid flow.
- 3.3** Remove protection covers from all connections and protective film from all name-plates, where appropriate, before installation on steam or other high temperature applications.
- 3.4** Valves must only be installed where 'weld neck' flanges are used. Other flange types may restrict operation. Rotate the valve body to ensure that the cast lugs centralise inside the flange bolts (see Figure 3)

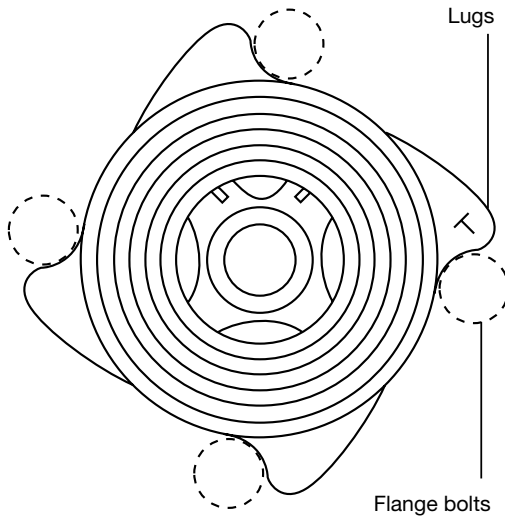

Fig. 3

3.5 Disc check valves simply fit between two pipe flanges (see Figure 4). Standard gaskets are used either side of the valve together with longer bolts or studs. **Note:** flanges, bolts (or studs), nuts and joint gaskets to be provided by the installer. Normal sensible flange bolting practice should be followed e.g. torque tightening the bolts in opposite sequence.

3.6 The DCV6 can be fitted between EN 1092 PN10, PN16, PN25 and PN40 flanges, JIS/KS, 10K (not DN80 or 100), 16K, 20K, 30K and 40K. They can be installed in any plane with the exception of DCV's supplied without an internal spring. These must be fitted in a vertical flow line with the flow from bottom-to-top i.e. upward flow (see Figure 3b).

Disc check valves must be fitted in accordance with the direction of the flow arrow on the body, indicating correct fluid flow direction.

Note: Disc check valves are not suitable for use where heavily pulsating flow exists, such as close to a compressor.

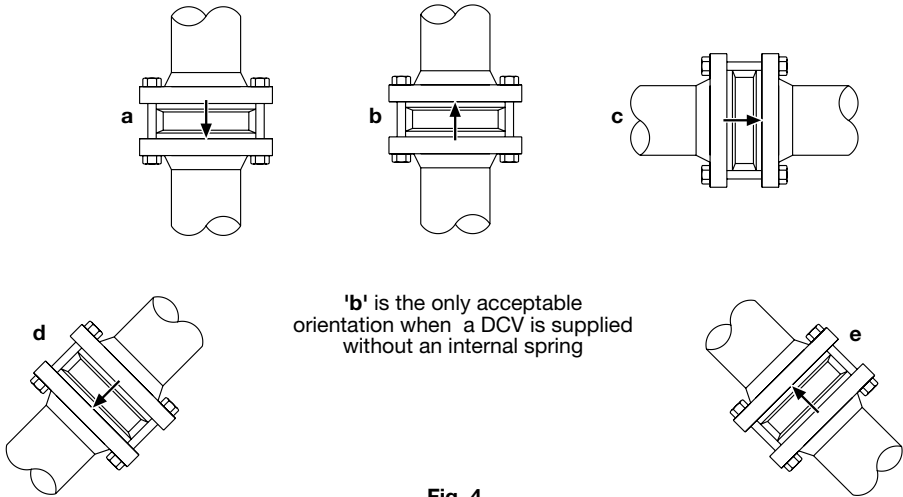

Fig. 4

4. Commissioning

After installation or maintenance ensure that the system is fully functional. Carry out tests on any alarms or protective devices.

5. Operation

Disc check valves are opened by the pressure of the fluid and closed by the spring as soon as the flow ceases and before the reverse flow occurs.

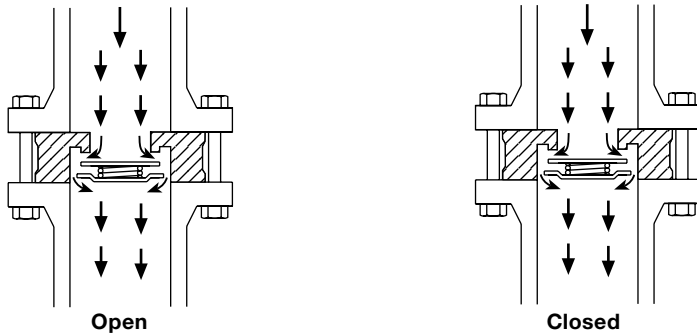

Fig. 5

K_V values

Size	DN15	DN20	DN25	DN32	DN40	DN50	DN65	DN80	DN100
K_V	4.4	7.5	12	17	26	39	58	86	158
For conversion	$C_V \text{ (UK)} = K_V \times 0.97$				$C_V \text{ (US)} = K_V \times 1.17$				

Opening pressures in mbar

Differential pressures with zero flow for standard and high temperature springs.

➔ Flow direction

Direction	DN15	DN20	DN25	DN32	DN40	DN50	DN65	DN80	DN100
↑	25	25	25	27	28	29	30	31	33
➔	22.5	22.5	22.5	23.5	24.5	24.5	25	25.5	26.5
↓	20	20	20	20	20	20	20	20	20

Where lowest opening pressures are required, valves without springs can be installed in vertical pipes with bottom-to-top flow.

Without spring

↑	2.5	2.5	2.5	3.5	4	4.5	5	5.5	6.5
---	-----	-----	-----	-----	---	-----	---	-----	-----

Heavy duty springs approximately 700 mbar

6. Maintenance

Note: Before actioning any maintenance programme observe the 'Safety information' in Section 1.

This product is non-maintainable.

Note: Great care must be taken if a DCV with a heavy duty spring is taken apart since the strength of the spring can cause the retainer to spring out of the body.

7. Spare parts

There are no spare parts available for this product.

How to order a new product

Example:

1 off Spirax Sarco DN25, DCV6 disc check valve for fitting between DN25, PN40 flanges.

