

CSM-C 600 Compact Clean Steam Generator

Installation and Maintenance Instructions



1. Safety information
2. General product information
3. Installation
4. Commissioning
5. Maintenance
6. Bolt torque
7. Spare parts
8. Fault finding
9. Warranty

1. Safety information

1.1 General safety information

Safe operation of this product can only be guaranteed if it is properly installed, commissioned, used and maintained by qualified personnel (see Section 1.2) in compliance with the operating instructions. General installation and safety instructions for pipeline and plant construction, as well as the proper use of tools and safety equipment must also be complied with.

Safety note - Handling precautions

PTFE

Within its working temperature range PTFE is a completely inert material, but when heated to its sintering temperature it gives rise to gaseous decomposition products or fumes, which can produce unpleasant effects if inhaled. The inhalation of these fumes is easily prevented by applying local exhaust ventilation to atmosphere as near to their source as possible.

Smoking should be prohibited in workshops where PTFE is handled because tobacco contaminated with PTFE will during burning give rise to polymer fumes. It is therefore important to avoid contamination of clothing, especially the pockets, with PTFE and to maintain a reasonable standard or personal cleanliness by washing hands and removing any PTFE particles lodged under the fingernails.

VITON

If Viton has been subjected to a temperature approaching 599°F (315°C) or higher it may have decomposed and formed hydrofluoric acid. Avoid skin contact and inhalation of any fumes as the acid will cause deep skin burns and damage the respiratory system.

1.2 Permits to work

All work must be carried out or be supervised by a suitably competent person. Installation and operating personnel should be trained in the correct use of the product according to the Installation and Maintenance Instructions. Where a formal 'permit to work' system is in force it must be complied with. Where there is no such system, it is recommended that a responsible person should know what work is going on and, where necessary, arrange to have an assistant whose primary responsibility is safety. Post 'warning notices' if necessary.

1.3 Limits of responsibility

This Installation, Operation, and Maintenance manual is intended to be as complete and up to date as possible. It covers the installation, operation, and maintenance procedures for Spirax Sarco CSM-C 600 compact clean steam generator. Spirax Sarco reserves the right to update this manual and other product information concerning installation, operation, and / or maintenance, at any time and without obligation to notify product owners of changes.

Spirax Sarco is not responsible for inaccuracies in specifications, procedures and / or the content of other product literature, supplied by other manufacturers of components used in Spirax Sarco Steam Generators (i.e.: valves, pressure controls, gauges, etc.).

Spirax Sarco uses only top quality components in the construction and control of its steam generators. Spirax Sarco accepts responsibility for complete systems only when it supplies all the components of the system. Otherwise Spirax Sarco accepts responsibility only for those parts that it has supplied, since it has no direct control over other manufacturers or their quality standards.

Note: The symbol  indicates 'warnings'.

 Spirax Sarco is not responsible for injury to personnel or product damage due to the improper installation, operation, and /or maintenance of Spirax Sarco CSM-C compact clean steam generators (see Section 1.1 - General safety information).

All installation, operation, and maintenance procedures should only be performed by trained/certified personnel. All personnel performing these procedures should completely and carefully read and understand all supplied materials before attempting the procedures. All personnel should pay strict attention to all Notes, Cautions, and Warnings that appear within the procedures detailed in this manual.

1.4 Intended use

Referring to the Installation and Maintenance Instructions, name-plate and Technical Information Sheet, check that the product is suitable for the intended use / application.

- i) Check material suitability, pressure and temperature and their maximum and minimum values. If the maximum operating limits of the product are lower than those of the system in which it is being fitted, or if malfunction of the product could result in a dangerous overpressure or over temperature occurrence, ensure a safety device is included in the system to prevent such over-limit situations.
- ii) Determine the correct installation situation and direction of fluid flow.
- iii) Spirax Sarco products are not intended to withstand external stresses that may be induced by any system to which they are fitted. It is the responsibility of the installer to consider these stresses and take adequate precautions to minimize them.
- iv) Remove protection covers from all connections and protective film from all name-plates, where appropriate, before installation on steam or other high temperature applications.

1.5 Access

Ensure safe access and if necessary a safe working platform (suitably guarded) before attempting to work on the product. Arrange suitable lifting gear if required.

1.6 Lighting

Ensure adequate lighting, particularly where detailed or intricate work is required.

1.7 Hazardous liquids or gases in the pipeline

Consider what is in the pipeline or what may have been in the pipeline at some previous time. Consider: flammable materials, substances hazardous to health, extremes of temperature.

1.8 Hazardous environment around the product

Consider: explosion risk areas, lack of oxygen (e.g. tanks, pits), dangerous gases, extremes of temperature, hot surfaces, fire hazard (e.g. during welding), excessive noise, moving machinery.

1.9 The system

Consider the effect on the complete system of the work proposed. Will any proposed action (e.g. closing isolation valves, electrical isolation) put any other part of the system or any personnel at risk?

Dangers might include isolation of vents or protective devices or the rendering ineffective of controls or alarms. Ensure isolation valves are turned on and off in a gradual way to avoid system shocks.

1.10 Pressure systems

Ensure that any pressure is isolated and safely vented to atmospheric pressure.

Consider double isolation (double block and bleed) and the locking or labelling of closed valves. Do not assume that the system has depressurized even when the pressure gauge indicates zero.

1.11 Temperature

Allow time for temperature to normalize after isolation to avoid the danger of burns and consider whether protective clothing (including safety glasses) is required.

PTFE seals - If seals made from PTFE have been subjected to a temperature approaching 500°F (260°C) or higher, they will give off toxic fumes, which if inhaled are likely to cause temporary discomfort. It is essential for a no smoking rule to be enforced in all areas where PTFE is stored, handled or processed as persons inhaling the fumes from burning tobacco contaminated with PTFE particles can develop 'polymer fume fever'.

VITON seals - If the Viton seat has been subjected to a temperature approaching 599°F (315°C) or higher it may have decomposed and formed hydrofluoric acid. Avoid skin contact and inhalation of any fumes as the acid will cause deep skin burns and damage the respiratory system.

1.12 Tools and consumables

Before starting work ensure that you have suitable tools and/or consumables available. Use only genuine Spirax Sarco replacement parts.

1.13 Protective clothing

Consider whether you and / or others in the vicinity require any protective clothing to protect against the hazards of, for example, chemicals, high / low temperature, radiation, noise, falling objects, and dangers to eyes and face.

1.14 Handling

Manual handling of large and /or heavy products may present a risk of injury. Lifting, pushing, pulling, carrying or supporting a load by bodily force can cause injury particularly to the back. You are advised to assess the risks taking into account the task, the individual, the load and the working environment and use the appropriate handling method depending on the circumstances of the work being done.

1.15 Residual hazards

In normal use the external surface of the product may be very hot. If used at the maximum permitted operating conditions the surface temperature of some products may reach temperatures of 365°F (185°C).

Many products are not self-draining. Take due care when dismantling or removing the product from an installation (refer to 'Maintenance instructions').

1.16 Freezing

Provision must be made to protect products, which are not self-draining against frost damage in environments where they may be exposed to temperatures below freezing point.

1.17 Disposal

This product may contain PTFE and Viton, special care must be taken to avoid potential health hazards associated with decomposition / burning of these materials. With the exception of the seal materials unless otherwise stated in the Installation and Maintenance Instructions, this product is recyclable and no ecological hazard is anticipated with its disposal providing due care is taken. However, all components should be checked individually to ensure they can be disposed of safely.

PTFE:

- Can only be disposed of by approved methods, not incineration.
- Keep PTFE waste in a separate container, do not mix it with other rubbish, and consign it to a landfill site. Viton:
- Waste parts can be landfilled, when in compliance with National and Local regulations.
- Parts can be incinerated, but a scrubber must be used to remove Hydrogen Fluoride, which is evolved from the product and with compliance to National and Local regulations.
- Parts are insoluble in aquatic media.

1.19 Returning products

Customers returning products to Spirax Sarco must provide information on any hazards and the precautions to be taken due to contamination residues or mechanical damage which may present a health, safety or environmental risk.

This information must be provided in writing including Health and Safety data sheets relating to any substances identified as hazardous or potentially hazardous.

— 2. General product information —

2.1 Description

The CSM-C 600 compact clean steam generator is configured and manufactured to use plant steam as the energy source for generating clean steam (to HTM2031, HTM2010, EN285 & CFPP01-01 part C 2013). It has been designed to generate up to 1,276 lb/hr. of clean steam at 45 psig from suitably treated water for sterilizing, humidifying and direct injection applications. Analysis of the feedwater system should be undertaken prior to installation and commissioning.

To meet the requirements of HTM2031 and EN285, the feedwater should be pretreated with one or more processes such as filtration, deionization, reverse osmosis, softening and de-chlorination to produce feedwater with the following characteristics:

pH: 6.5 – 8.5

Hardness: absent

Chlorine: absent

Conductivity: <600 ppm Total Dissolved Solids

Construction

All components and materials included in the manufacture of the CSM-C 600 compact clean steam generator have been specifically selected to meet the individual design specifications and HTM2031, HTM2010, EN285 & CFPP01-01 part C 2013. All parts in contact with generated steam and treated feedwater are AISI 316L stainless steel. The CSM-C 600 compact clean steam generator is, as standard, equipped with an approved safety valve and an external drain that provides a means of removing accumulated sediment in the vessel. Spirax Sarco supplies all of the components to control the CSM-C 600 compact clean steam generator which are manufactured to the highest quality.

Standards

This unit is designed, built and stamped in accordance with ASME Section VIII, Div.1.

2.2 Controls

The Spirax Sarco CSM-C 600 compact clean steam generator is equipped with pneumatically activated controls to regulate steam pressure and water level. The electronic PLC control panel has a power requirement of 110 VAC, 50-60 Hz, single phase. In most cases where pneumatically activated controls are used, they require a minimum air pressure supply of 90 psig (6 bar g). Consult the individual design specifications of the unit and controls supplied for the exact requirements.

2.3 Outputs

Plant Steam Pressure	Clean Steam Production* (lb/hr.) at:						
	75 psig	60 psig	45 psig	37.5 psig	30 psig	22.5 psig	15 psig
150 psig	836	1,122	1,496	1,760			
135 psig	660	946	1,276	1,496	1,804		
120 psig	462	748	1,078	1,276	1,540	1,870	
105 psig		550	880	1,056	1,276	1,562	1,892
90 psig			638	836	1,034	1,276	1,628
75 psig				594	792	1,012	1,298
60 psig					528	748	1,012
45 psig						462	704

*Feedwater at 60°F

Note: Feedwater pressure must be at least 15 psig greater than desired clean steam pressure



= HTM2031/2010 & EN285 compliance guaranteed

= HTM2031/2010 & EN285 compliance not guaranteed

= Inadequate thermodynamic conditions

2.4 Name-plates

A name-plate, mounted to the generator body, bears the model and serial numbers of the steam generator unit, while a name-plate mounted on the skid bears the package number.

 These numbers should be included in all correspondence regarding the unit.



Package name-plate

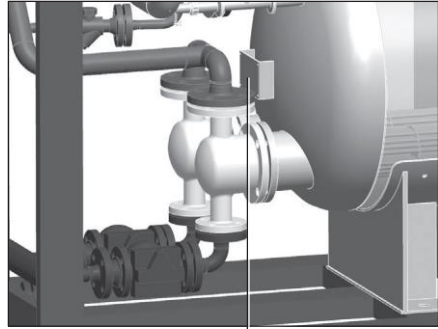

Generator name-plate

Fig. 1

2.5 Insulation

The Spirax Sarco CSM-C 600 compact clean steam generator has insulation on the generator shell and pipework.

2.6 Heat exchanger

The heating coil ('U' tube bundle) and the connection piece used to mount the coil in the generator vessel are constructed from AISI 316L stainless steel.

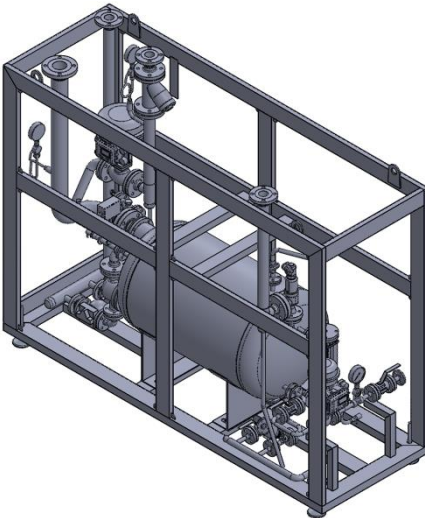

Fig. 2

2.7 Warranty information

All components used in the manufacture of Spirax Sarco CSM-C 600 compact clean steam generator is warranted for one (1) year from commissioning or eighteen (18) months from the date of delivery, whichever comes first. In some cases, extended warranties are available on an individual basis, at extra cost.

3. Installation

3.1 General notes

This manual is intended to cover installation, operation, and maintenance procedures for Spirax Sarco CSM-C 600 compact clean steam generators. If specific installation, operation, and / or maintenance procedures are not clearly understood, contact Spirax Sarco for clarification before proceeding.

All installation, operation, and maintenance procedures should only be performed by experienced, trained, and qualified personnel. Personnel should be trained in correct piping and electrical procedures and methods, and should be experienced in working with steam and thermal oil / superheated water systems. The Spirax Sarco CSM-C range of compact clean steam generators are designed for indoor use only, unless otherwise required by design specifications. Each unit requires at least three feet clearance at the front and rear, and two feet to each side and above the unit. It should be located on a level surface (no more than one-half degree [$\frac{1}{2}^\circ$] of slope), capable of supporting the total weight of the unit when filled to capacity. The unit should be mounted to the floor following applicable architectural and local code requirements for the specific installation site.

Maintenance procedures are detailed in Section 5.

Fault finding procedures are detailed in Section 8.

Should the unit be damaged during installation, operation, or maintenance, complete the following steps:

1. Isolate the primary steam supply inlet valve.
2. Turn off the power to the unit.
3. Close the condensate water return valves.
4. Close the clean steam outlet valve (if present).
5. Close the feedwater inlet valves.
6. Contact in-house maintenance personnel.

All pipework connections for clean steam and feedwater should be flanged or sanitary type in design, the type of gasket material should be suitable for clean steam applications.

3.2 Warnings

Listed on the following pages are specific warnings pertaining to Spirax Sarco CSM-C clean steam generators. In addition, throughout this manual, warnings are restated when procedures are described pertaining to areas of potential danger. All warnings should be carefully read and understood. All precautions contained in the warnings should be carefully followed to reduce the chance of injury.



Areas of potential danger:

1. All steam and water lines, joints and valves;
2. All power connections and cables;
3. All pneumatic (instrument air) lines and joints.



Before attempting any installation, operation, or maintenance procedures pertaining to the unit:

1. Ensure that the primary steam supply has been isolated at the manual shut-off valve;

2. If the unit has been in operation, allow the clean steam and water in the generator, as well as all components and surfaces (clean steam outlet lines, primary steam inlet lines etc.) to cool;
3. Ensure that all power has been shut off / disconnected;
4. Ensure that steam inlet and outlet, condensate outlet and feedwater inlet lines have been isolated at the manual shut-off valves;
5. Ensure that the pneumatic source has been isolated and the pressure bled from the lines.

 Operating conditions can be very dangerous due to the fact that the steam is under pressure and at very high temperatures.
To avoid possible injury or death, follow all accepted and recommended procedures when performing installation, operation and maintenance procedures.

 The combination of electricity and water can pose a very dangerous situation. Ensure that all power has been shut off / disconnected before attempting any installation or maintenance procedures.

3.3 Product features and specifications

The CSM-C 600 compact steam generator, using heating coils ('U' tube bundles), is the most economical method of producing clean steam when steam is used as the energy source. All Spirax Sarco CSM-C 600 compact clean steam generators are packaged ready for installation. All components are sized, mounted, piped, and tested prior to shipment. Each unit is built to exact design specifications and requires only connection to plant steam, feedwater, power, safety discharge, blowdown discharge and pneumatic sources to be ready for operation. The packaged concept provides a compact size that is ideal for new installations, or for use as the replacement of an existing steam generator(s). The compact size requires less space for installation. All components used in the unit are of the highest quality and meet all design requirements. Each unit is supplied with all relevant documentation, inclusive of each major component, to perform installation, operation and maintenance procedures. If any of these documents are missing, contact either Spirax Sarco or your authorized sales representative before attempting any installation, operation, or maintenance procedure.

3.4 Installation transporting and unpacking the unit

CSM-C compact clean steam generators are usually shipped uncrated. The units can be lifted by means of a forklift truck, placing the forks on the underside of the frame structure in a central position thus evenly distributing the weight of the unit and providing a stable, balanced load, refer to Figure 3.

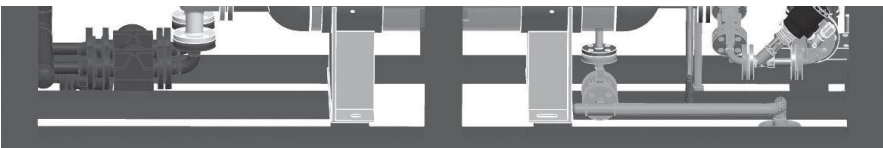

Place the forks of the forklift truck here

Fig. 3



Place the forks of the forklift truck here



If crated when shipped, the unit should only be lifted at the areas indicated on the crate. Improper lifting of the unit may result in damage to the unit.

3.5 Location requirements

The CSM-C 600 compact clean steam generators are designed for indoor use only unless otherwise required by the design specifications. The unit should be located on a level surface (no more than one-half degree [$\frac{1}{2}^\circ$] of slope), capable of supporting the total weight of the unit when filled to capacity. If crated when shipped, the crating should be carefully removed. The unit can then be maneuvered into place using the mounted wheels (optional), safely installed and then secured using the four foot mounts (standard).

3.6 Examining the unit

It is the user/installer's responsibility to thoroughly inspect the unit at the time of delivery to validate that no damage has occurred during shipping. After the unit has been set in place, it should be carefully examined again to ensure that neither the main unit nor any of the components have been damaged during the positioning and installation process. If any evidence of damage is detected, contact Spirax Sarco or your authorized sales representative to report the damage and to receive instructions on how best to proceed. After the unit and all components have been inspected for damage, it is suggested that all pressure and control components be checked to ensure that they are to design specifications. This can be done by reviewing the design specifications included with the unit. Contact Spirax Sarco or your authorized sales representative, before proceeding with the installation if any non-conformances are found.

3.7 Mounting the unit

The unit should be mounted to the floor using the four individual foot mounts supplied as standard, following applicable local code requirements, or accepted standards for the specific installation site and for the unit purchased.

3.8 Installation - Preliminary procedures

Install the CSM-C compact clean steam generator by following this simple procedure:

1. Connect the feedwater supply to the feedwater inlet - Section 3.9
2. Connect the generated clean steam outlet to the clean steam supply - Section 3.9
3. Connect the safety valve and discharge to a safe area - Section 3.10
4. Connect the primary steam supply to the primary steam inlet - Section 3.11
5. Connect the condensate return outlet to the condensate return line - Section 3.12
6. Connect the appropriate instrument (control) air supply - Section 3.13
7. Connect the drain / bottom blowdown connection to the correct system pipework - Section 3.14
8. Connect the system sampling points - Section 3.15
9. Connect the electrical connections and power supply - Section 3.16



The drawings used in this manual are examples only and show standard connections. For connection locations and specifications (type and size) of the ordered unit always refer to the drawings supplied with the unit.

3.9 Connecting the feedwater supply and generated clean steam outlet

- ⚠ Note:** Before connecting to feedwater inlet or generated clean steam outlet on the unit, ensure that all pipework is clean and free of foreign material or scale. This can usually be accomplished by 'blowing out' the pipe. Any foreign material or scale entering the unit can adversely affect operation and performance.

3.9.1 Feedwater supply

The first step in the installation process is to connect the feedwater supply to the feedwater inlet connection - see Figure 4.

A 316L stainless steel manual shut-off valve should be installed upstream on the feedwater supply as an isolation device. The shut-off valve should be in the closed position and remain so until the installation is complete.

- ⚠ Note:** All pipework connections for clean steam and feedwater should be flanged or sanitary type in design, the type of gasket material should be suitable for clean steam applications.

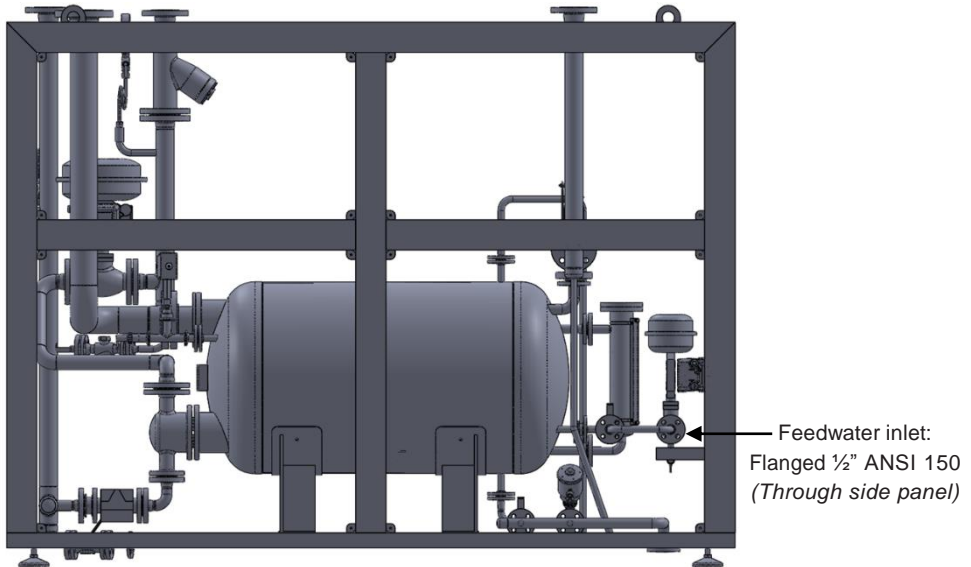

Fig. 4

3.9.2 Generated clean steam outlet

The next step in the installation process is to connect the generated steam system pipework to the clean steam outlet connection (Figure 5). A manual shut-off valve should be installed downstream on the generated clean steam outlet pipe for isolation purposes in case the unit is disconnected from the system. The shut-off valve should be in the closed position and remain so until the installation is complete.

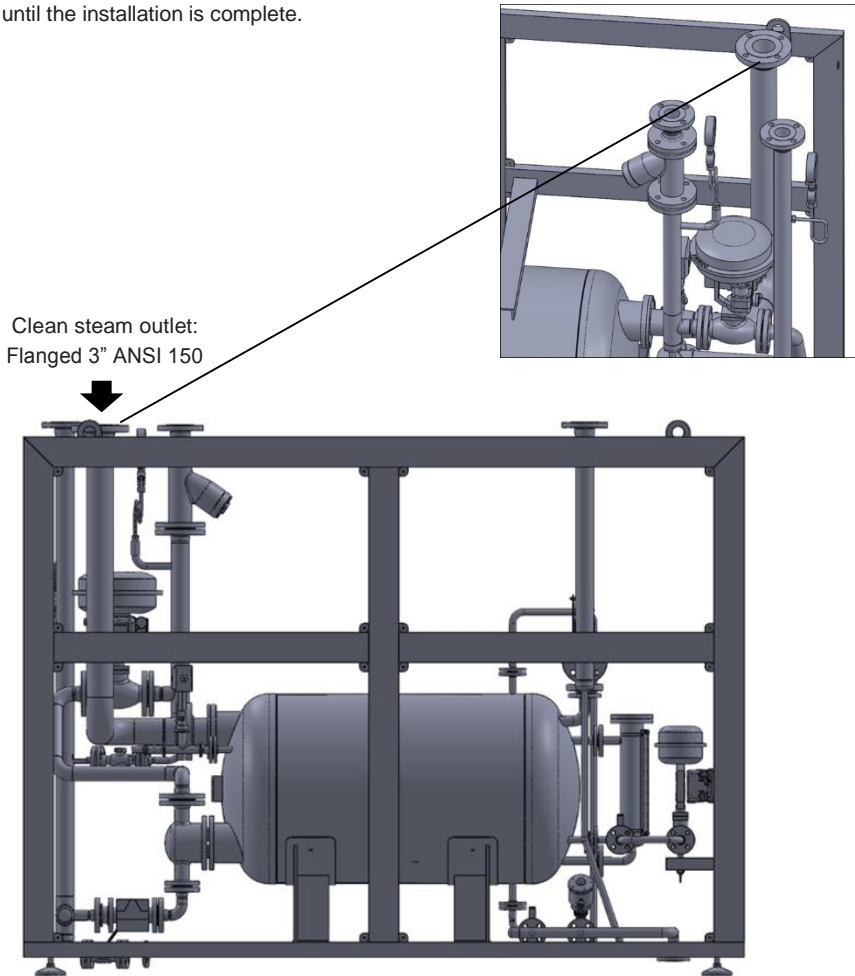

Fig. 5

⚠ Note: Refer to local regulations and specifications for site specific shut-off and check valve requirements.

Note: All pipework connections for clean steam and feedwater should be 316L stainless steel flanged or sanitary type in design, the type of gasket material should be suitable for clean steam applications.

3.10 Piping the safety valve to vent and drain

All Spirax Sarco CSM-C compact clean steam generators are equipped with a pressure safety valve. In most applications, the pressure safety valve should be vented to atmosphere (generally through the roof).

The piping used in the vent system must be of adequate size to handle the capacity of the pressure safety valve.

The vent piping system should allow for condensate drainage and should be piped to a suitable drain (Figure 6). Piping the pressure safety valve to a suitable vent and drain will prevent both water and heat damage to the unit, as well as reduce the risk of injury from released steam. All safety discharge pipework should comply with local codes. It is the responsibility of the purchaser / installing contractor to ensure this compliance.

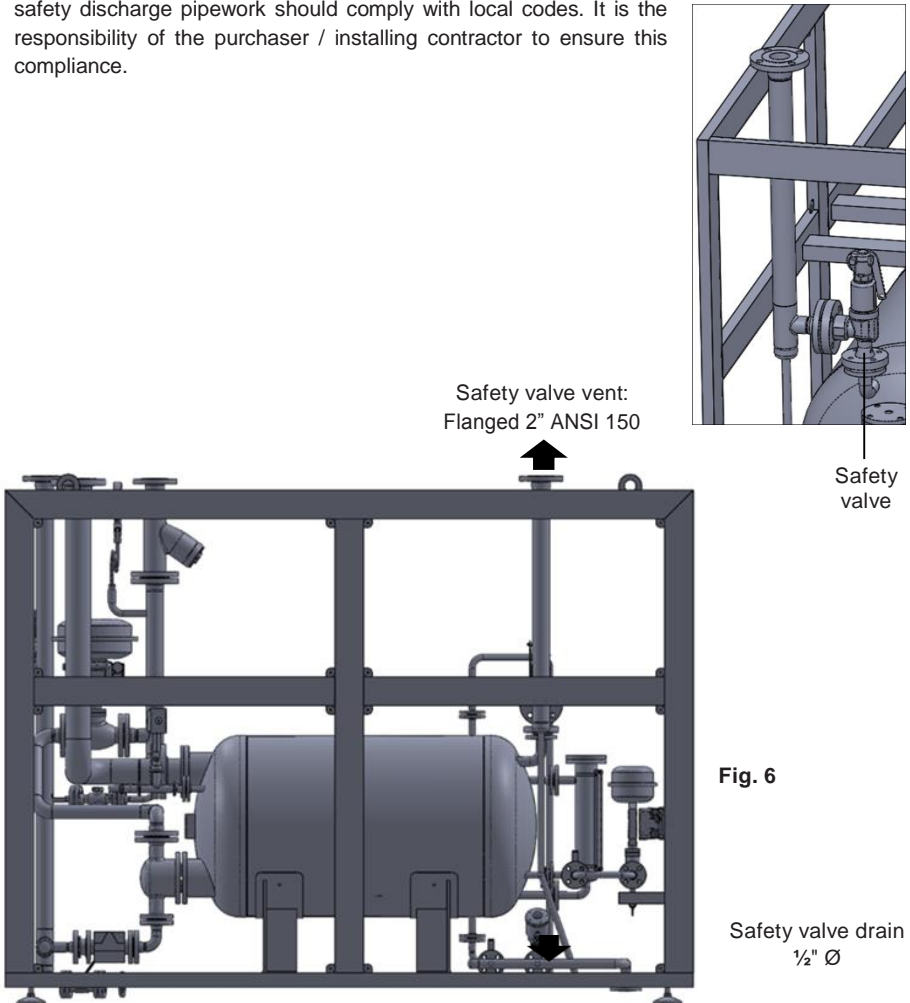

Fig. 6

 Installation should be done according to local standards.

3.11 Connecting the plant steam supply

 **Possible injury or death.**

Ensure that a manual shut-off valve is installed upstream on the plant steam supply line and that it is functioning correctly. If there is any doubt about the integrity of the valve, it must be replaced before attempting any installation. All plant steam supply line valves should be closed and remain closed throughout the installation process. Connect the plant steam supply line to the plant steam inlet connection (Figure 7).

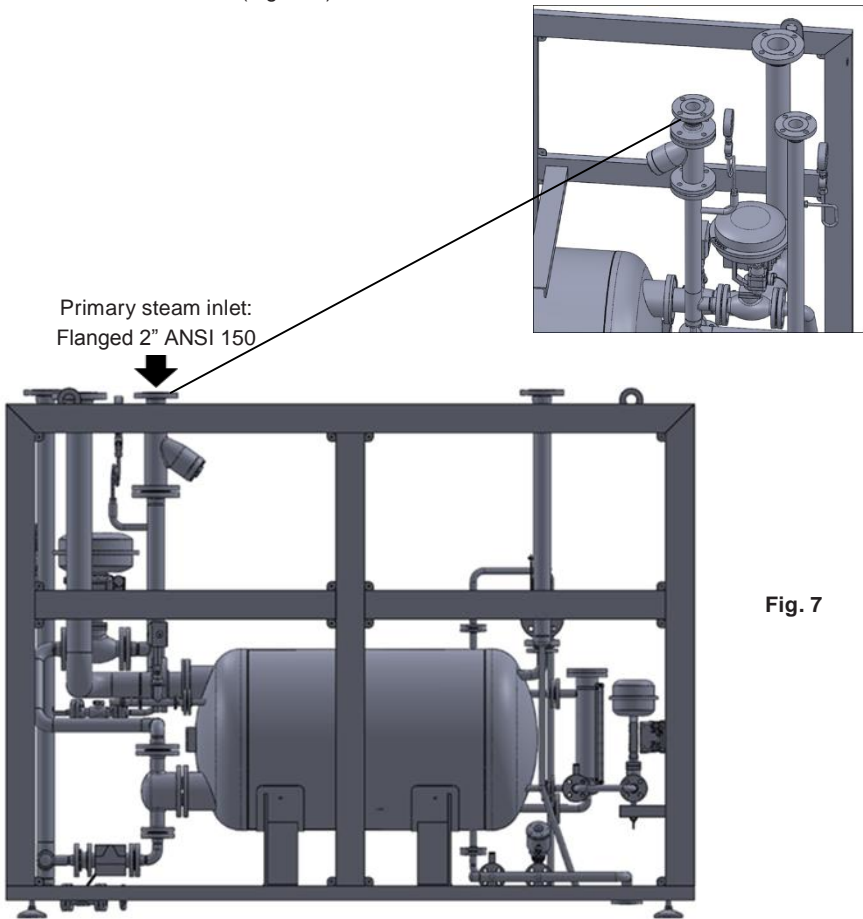

Fig. 7

3.12 Connecting the condensate return line

As the heat from the plant steam supply is extracted and transferred to the clean steam generating system, condensate will form and should be removed from the system by connecting the condensate return line to the condensate return outlet connection (Figure 8). The condensate return line should then be piped back into a suitable condensate return system. A manual shut-off valve should be installed downstream on the condensate return line to allow for the unit to be isolated from the condensate return system and prevent back flow of condensate if the line is disconnected.

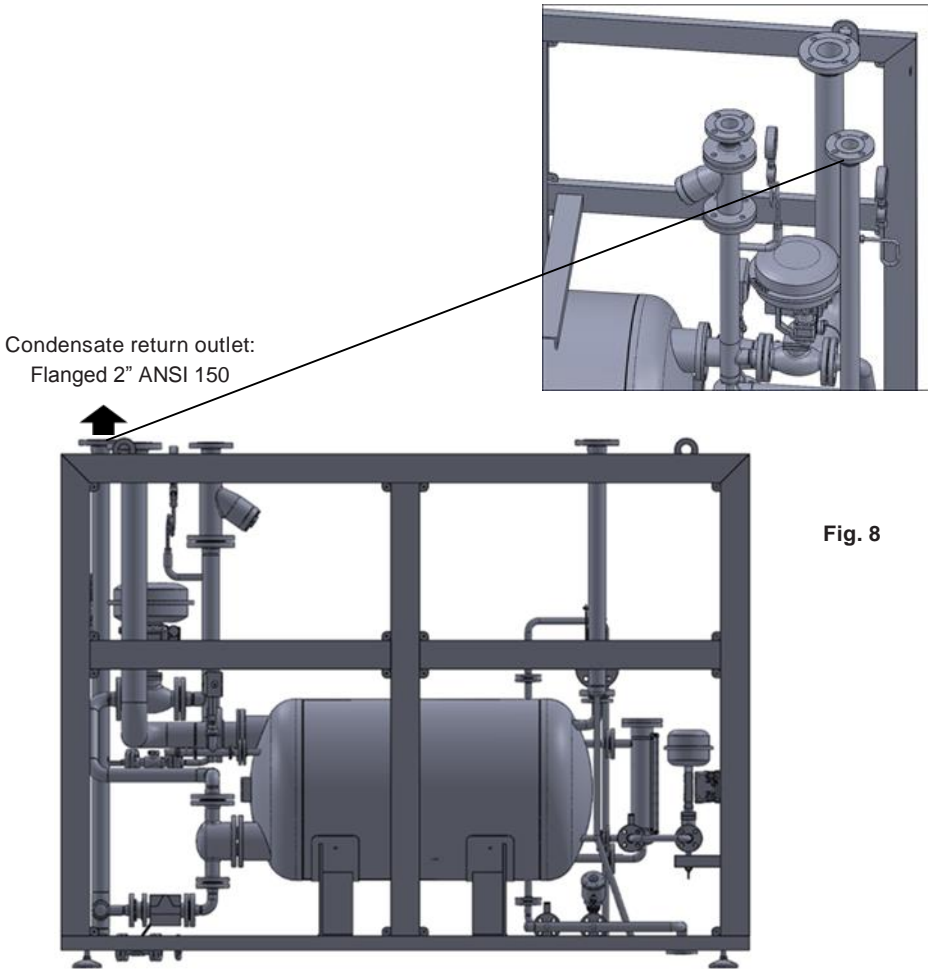

Fig. 8

3.13 Connecting electro-pneumatically activated controls

The Spirax Sarco CSM-C 600 compact clean steam generator is equipped with pneumatically activated controls. In most cases where pneumatically activated controls are used, they require an instrument air pressure supply of 90 psi g (Figure 9). Refer to the supplied drawing, and specific installation and operation instructions for each component to determine the requirements for that particular component.

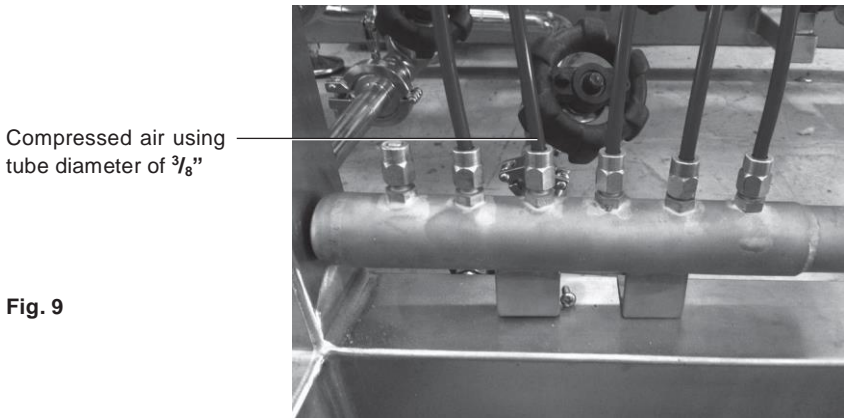

Fig. 9

⚠ Ensure that the pneumatic air supply has been shut down, and air pressure bled from the system by acceptable methods, before attempting any connections.

Reference the drawings that are included, or the installation instructions contained in the Installation Manual for the component, for specific piping instructions.

⚠ Note: For all pneumatic connections, the use and / or type of joint compound or sealer on the joint should be determined by referring to local codes, accepted practices, or the requirements of the installing contractor.

3.14 Connecting the drain / bottom blowdown line

Spirax-Sarco CSM-C compact clean steam generators are equipped with a drain/bottom blowdown line. Each generator has an automatic (timed) blowdown valve fitted as standard which is connected to the bottom of the vessel (Figure 10).

- ⚠ The blowdown from this valve is at the pressure and temperature of the generated steam and can cause severe injury or death if not properly piped. In accordance with local regulations or standards, it is recommended that the blowdown lines be connected to a blowdown vessel or condensate cooler before being discharged to drain.**

Fig. 10

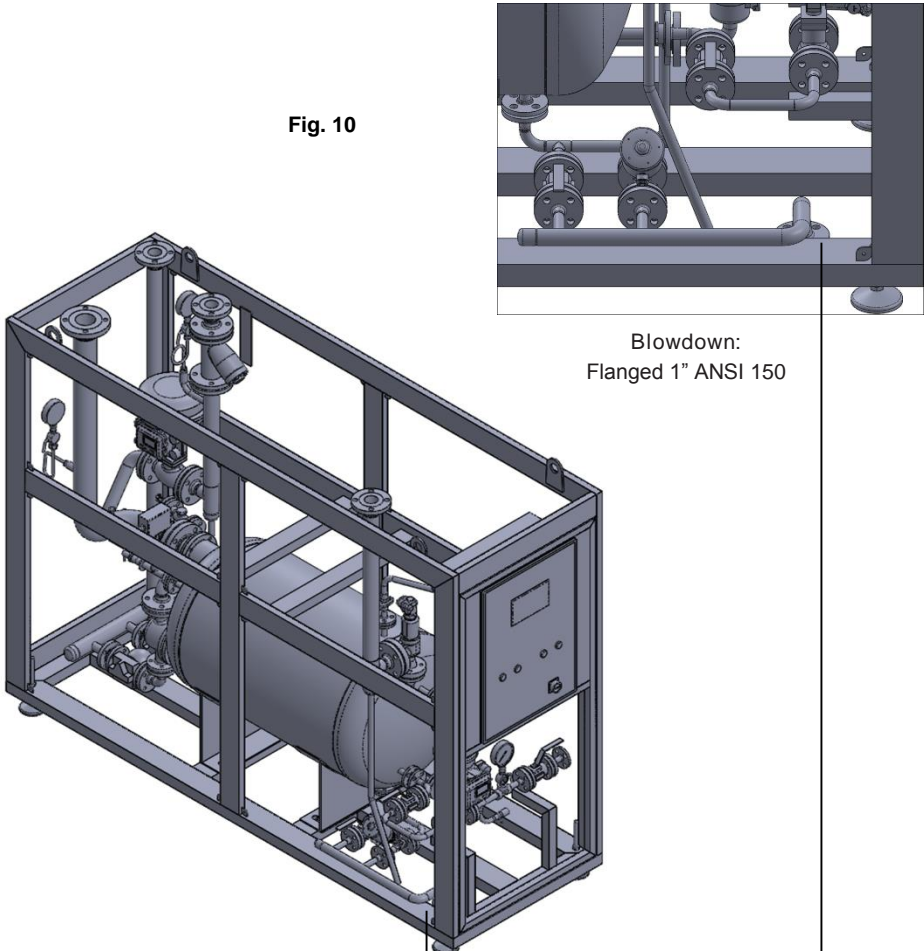

- ⚠ Note: Blowdown connection should be performed in accordance to local codes, accepted practices, or the requirements of the installing contractor.**

3.15 System sampling points

Spirax Sarco recommends the installation of sample points throughout the system.

HTM 2031, HTM 2010, EN 285 & CFPP01-01 part C 2013 specify that throughout the process of clean steam generation, system sampling should be facilitated, as a minimum, at the following points:

- Generator feedwater.
- Clean steam from the generator.

These points will allow for easy sampling and testing of the system. For further information contact Spirax Sarco.

3.16 Electrical connections and power supply

 **Attention: the user is responsible for electrical connections to the package.**

 **Attention: do not route signal and control wiring with power wiring in the same conduit. This can cause interference with operation. Failure to observe this precaution could result in damage to, or destruction of, the unit.**

 **Attention: a power disconnect device must be installed by the user, between the general power line and the cabinet. If the power disconnecting device is a circuit breaker, the circuit breaker must be able to trip 5 Amps. It is important to verify that the main power will meet input power requirements of the control cabinet. Be sure that input power corresponds to the name-plate voltage and frequency.**

 **Attention: unused wires in conduit must be grounded at both ends to avoid a possible shock hazard caused by induced voltages.**

3.16.1 Grounding the cabinet

 **Attention: the user is responsible for conforming to all the applicable local, national and international codes. Failure to observe this precaution could result in damage to, or destruction of the equipment.**

Use the following steps to ground:

Step 1: Open the cabinet door.

Step 2: Run a ground unbroken conductor from the control cabinet ground terminal to the earth ground. Ground cable must be not less than 9 AWG.

3.16.2 Mains power supply

Display: 5.7" Touch-screen with high resolution color graphics.

Input voltage: 110 VAC, 50-60 Hz, Single Phase (**always refer to wiring diagram**).

Input contacts: 3 A – 110 V for inductive loads.

Output contacts: 5 A – 110 V for resistive loads.

Operational ambient temperature: Minimum 32°F to a Maximum 122°F (inside the control cabinet)*.

Relative Humidity (RH): from 5% to 95% non-condensing.

3.16.3 Installing power input lines

Use the following steps to connect an AC input power supply to the control cabinet:

Step 1: Wire the AC input power leads by routing them in the cabinet unit through the plug.

Step 2: Connect input power cables to the power supply terminal block: Live to terminal L3, Neutral to terminal L1 and the Ground to the Ground screw connection

Step 3: Tighten the AC input terminals.

Installation completion - Installation of the CSM-C compact clean steam generator is only complete when all of the Sections within 3 have been actioned and checked by a safety officer.

4. Commissioning

After all installation procedures have been completed within Section 3, and all clean steam, feedwater, plant steam, pneumatic joints, and power connections have been double checked by a safety officer, the unit is ready for commissioning.

4.1 Commissioning procedure

Commissioning may now be carried out in accordance with the following procedure.

Please note: It is strongly recommended that this procedure is always carried out by a qualified Spirax Sarco engineer.

Installation inspection:

1. Ensure that the unit has been installed in line with Spirax Sarco recommendations as specified in Section 3.
2. Ensure that the blowdown and safety valve lines are piped away to a safe location.
3. Ensure that all manual isolation valves have been closed: plant steam inlet, clean steam outlet, feedwater inlet, pneumatic supply and condensate outlet.

Pre-commissioning inspection:

4. Check that all flanged connections within the generator are tight.
5. Check the electrical connections.
6. Check that the supply voltage is correct.
7. Check that the pneumatic supply is correct.

4.2 Start-up operating procedure

4.2.1 Cold start-up

The following procedure must be followed when bringing the clean steam generator into operation from an isolated and empty condition:

1. Ensure that all manual isolation valves are in a fully closed position.
2. Turn on the electrical power supply.
3. Turn on the compressed air supply.
4. Open the manual isolation valve for the treated feedwater supply.
5. Press the generator **START** key on the control panel touch screen.
6. Observe the rise in the displayed water level on the control panel generator synoptic screen.
7. Check that the generator stops filling when the set point level is reached.
8. Open the condensate return manual isolation valve.
9. Slowly open the primary (plant) steam supply manual isolation valve.
10. Observe that the generator reaches the programmed set point pressure on the synoptic screen.
11. Leave the generator in operation for sufficient time to allow any non-condensable gases to dissipate.
12. Slowly open the clean steam outlet manual isolation valve.
13. The unit is now ready for operation.

Note: For further information on procedure steps 5, 6, 7, & 10, please refer to the PLC Control Unit Manual IM-P486-19-US.

4.2.2 Cycle interrupted

The following procedure must be followed when bringing the generator back on line following an alarm condition lockout or temporary shutdown:

1. Check that the generator pressure is above 1.5 psig via the generator synoptic screen.
If this is not the case then the cold start-up procedure must be followed - Section 4.2.1.
2. Check that the 'Emergency Stop' button on the front of the control panel has been released.
Also check that all remote stops have been released.
3. Press the manual reset button on the front of the control panel.
4. Check that all manual isolation valves are in an open position.
5. Press the **MAIN START** key on the control panel touch screen - the generator will come back on line

Note: For further information on procedure steps 1, 2, 3, and 5, please refer to the PLC Control Unit Manual IM-P486-19-US.

4.3 General operating procedure

4.3.1 Configuration parameters

For further information, please refer to the PLC Control Unit Manual IM-P486-19-US Section 4.2 'Protected parameters'.

4.3.2 Manual operation

For further information, please refer to the PLC Control Unit Manual IM-P486-19-US Section 4.3 'Manual cycle'.

4.3.3 Automatic operation

For further information, please refer to the PLC Control Unit Manual IM-P486-19-US Section 4.3 'Automatic cycle'.

4.4 Shutdown operating procedure

The following procedure must be followed when shutting down the unit for extended periods such as over weekend or for maintenance purposes:

1. Close the plant steam supply manual isolation valve.
2. Close the manual isolation valve for the treated feedwater supply.
3. Close the condensate return manual isolation valve.
4. Allow the generator pressure to fall to atmospheric.
5. Close the clean steam outlet manual isolation valve.
6. Press the **MAIN STOP** key on the control panel touch screen.
7. Open the manual drain valve and leave it open until the generator vessel is empty.
8. Close all other manual isolation valves and lock out.
9. Turn off the electrical power supply.

4.5 Emergency shutdown procedure

The following procedure must be followed in the event that an emergency shutdown is required.

The emergency shutdown procedure must only be used in the event of an unusual occurrence that requires the rapid isolation of the clean steam supply or in the unlikely event of a malfunction within the clean steam generator.

1. Press the 'Emergency Stop' button either on the front of the control panel or at the remote location.
2. Close the plant steam supply manual isolation valve.
3. Close the clean steam outlet manual isolation valve.
4. Close all other manual isolation valves and lock out.

4.6 Daily maintenance

The clean steam and plant steam pressures should be checked at their respective pressure gauges **at least twice a day**.

4.7 Bottom blowdown

Spirax Sarco CSM-C compact clean steam generators are equipped with a drain and bottom blowdown line. Blowdown is controlled using either a manual isolation valve (fitted as standard) or an automatic blowdown valve (optional) which is connected to the bottom of the generator vessel. The automatic blowdown valve can be programmed through a timer in the PLC control unit to set / adjust the frequency and duration of discharged boiler water.

 **The blowdown from this valve is at the pressure and temperature of the generated steam and can cause severe injury or death if not properly piped. It is recommended that the blowdown lines be connected to a blowdown vessel before being discharged to drain.**

 **The blowdown from the CSM-C compact clean steam generator can flash to steam when introduced to atmospheric pressure.**

Spirax Sarco recommends the use of automatic blowdown valves with its generators. The build-up of scale and dirt within the unit can effect operation and the quality of the clean steam and shorten the life of the unit. **The unit should be blown down a minimum of once a day.**

The frequency of necessary blowdown is directly affected by the minerals, chemicals, and contaminants contained in the feedwater.

Depending on the water quality, the blowdown interval may need to be altered (either more or less frequently) for each site.

4.8 Feedwater

CSM-C compact clean steam generators are equipped with a PLC level controller which will activate the feedwater control valve to maintain the correct water level in the generator. The PLC level controller will send a signal to the control valve to feed water to the generator when the level falls under the set-point level and stop feeding when the water level reaches the set point. The level controller also has a low water alarm position which will activate if the water falls below the predetermined alarm, set on the PLC. There are also two level limits installed in the same level sensor (Figure 11) that are calibrated for low and high levels. If a low level condition occurs, the primary steam supply is isolated, an alarm will be activated and the generator will shut down.

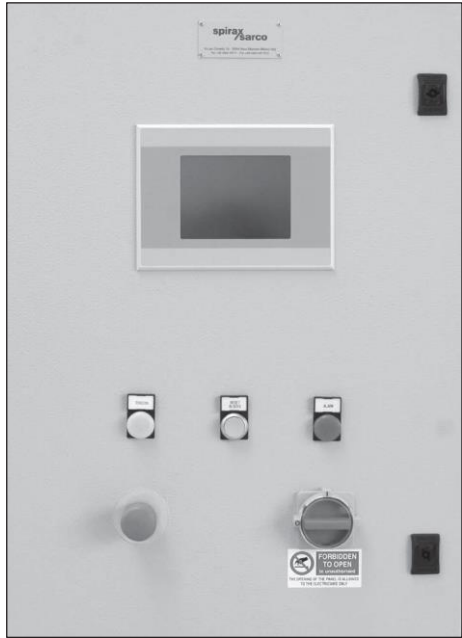
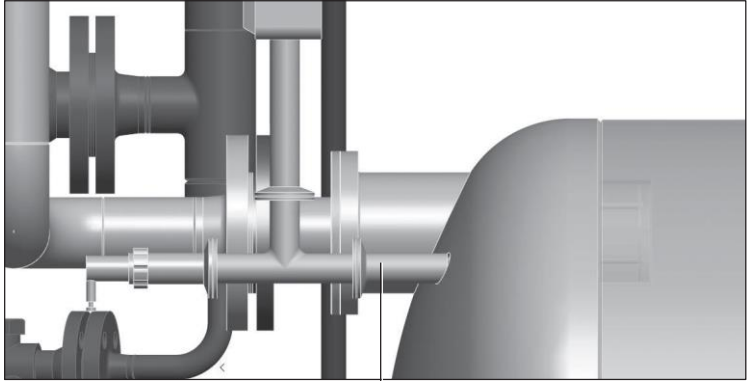

Fig. 11

4.9 Clean steam pressure

Clean steam pressure is controlled by a pressure transmitter which is installed on the head of the generator vessel (Figure 12). The pressure transmitter sends a 0 - 10 V signal (equivalent to 0 – 90 psig range) to the PLC control unit where it is processed and used to adjust the control signal to the primary steam supply pneumatic control valve (Figure 13), modulate the flow of steam into the heating coil(s) ('U' tube bundle(s)) and thus maintain a constant clean steam supply pressure.

Fig. 12



Pressure transmitter
(Clean steam)

Fig. 13

Pneumatic control valve
(Plant steam)

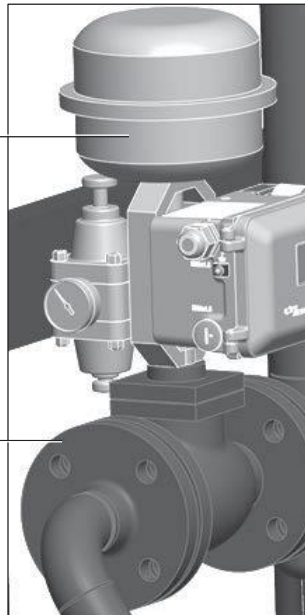

5. Maintenance

See Section 5.5 for a recommended maintenance schedule.

5.1 General information

The information contained in this Section will detail service and maintenance procedures for the inspection and replacement of components used in the manufacture of the Spirax Sarco CSM-C compact clean steam generator range. Please note that this manual may be general in some instances. If there are any questions concerning maintenance procedures that are not clearly explained in this manual, contact Spirax Sarco. **Please note:** Be sure to have the model and serial numbers of the unit and heating coil(s) available before making contact.

It is strongly recommended that major maintenance procedures are performed by a certified Spirax Sarco Service Technician.

 **Note: Many of the maintenance procedures detailed in this Section will require the unit to be taken off-line before the procedure is performed; and put back online after the procedure is completed. It is recommended that the maintenance personnel performing these procedures review the start-up and shutdown procedures, detailed in Sections 4.2 and 4.4, before attempting any maintenance procedure.**

Any component(s) directly connected or linked to the component being replaced should carefully be examined before maintenance procedures are started. If any of the related components show signs of wear or improper operation, they should be considered for replacement at the same time.

5.2 Power connections - Rewiring

If any power connections to electrically activated controls or junction boxes require rewiring, follow the steps listed below.

 **The combination of electricity, steam, and water can pose a very dangerous situation. Turn off/disconnect electric power before attempting any maintenance procedure.**

1. Follow the shutdown procedure (Section 4.4) to take the unit off-line before attempting any electrical service.
2. After ensuring that the power has been turned off, disconnect and rewire the electrical connections in question.
3. Turn the power on and check that the component that has been rewired is functioning properly.
4. Follow the start-up procedure in Section 4.2 of this manual to return the unit to operation.

5.3 Pneumatic (air) connections - Refitting

If any pneumatic (instrument air) connections to pneumatically activated controls require refitting, follow the steps listed below.

⚠ Air, at a pressure of 90 psig is, in most cases, required to activate pneumatic controls. Air pressure at this level can pose a very dangerous situation. Ensure that the air source has been shut down and that the line pressure has been relieved before breaking any pneumatic connection.

1. Follow the shutdown procedure (Section 4.4) to take the unit off-line before attempting any pneumatic service.
2. After ensuring that the air supply has been turned off, break and rework the pneumatic connections in question.
3. Turn the air supply on and check that the component that has been reconnected is functioning properly.
4. Follow the start-up procedure in Section 4.2 of this manual to return the unit to operation.

5.4 Equipment and components – Inspection and or replacement

5.4.1 Heating coils ('U' tube bundles)

The heating coils are fundamental to the successful operation of the CSM-C compact clean steam generator. Dependent upon insurance requirements they should be removed and inspected at least every two (2) years by following the procedure outlined below.

There are two (2) gaskets for each coil. One (1) is located between the underside of the tubesheet and the front face of the vessel flange and one (1) is located between the front face of the tubesheet and the underside of the header flange (see Figure 14).

Fig.14

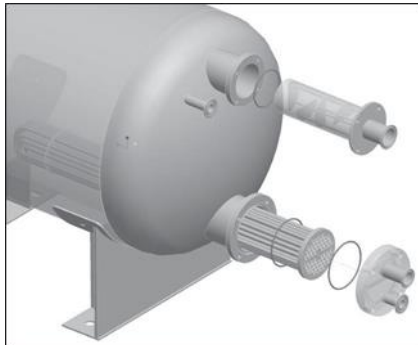

⚠ The clean steam and plant steam systems can be very dangerous because of the high temperatures and pressures. To avoid possible injury or death, follow all accepted and recommended procedures when performing installation, operation and maintenance procedures.

⚠ The combination of electricity, steam, and water can pose a very dangerous situation. Turn off/disconnect all electric power before attempting any maintenance procedures.

1. Follow the shutdown procedure (Section 4.4) to take the unit off-line before attempting to remove and inspect the heating coil.
2. Ensure that the pressure has been relieved from the clean steam and plant steam systems and that all components and surfaces have cooled.
3. Carefully break the connections between the heating coil header and the plant steam inlet and condensate outlet lines noting the following:
 - a. It may be necessary to break the lines at a second location, and for the lines to be rotated to allow clearance for the heating coil to be removed from the vessel.
 - b. Care should be taken to ensure that in-line components are not damaged during this procedure.
4. Remove the bolts and nuts from the flanged connection securing the heating coil header to the vessel.
5. Carefully separate the heating coil header from the vessel flanged connection and withdraw the coil assembly ('U' tube bundle) from the vessel.

⚠ There may still be residual steam condensate (or boiler / high temperature water), this residual condensate/water could present a danger of injury. Allow sufficient time for cooling before removing the heating coil from the vessel.

6. Examine the heating coil ('U' tubes) for scale build-up and signs of leakage. If no leakage is detected, carefully clean the excess scale from the coil and prepare for installation. If leakage is detected, either repair the leaking coil(s) or replace the complete coil assembly ('U' tube bundle).
7. Remove the old gaskets and thoroughly clean the mating surfaces on the flange connections and tubesheet. Install two (2) new gaskets as shown in Figure 15.
8. Carefully insert the heating coil assembly into the vessel, ensuring that the divider in the header is aligned with the coil and is parallel to the horizontal.

⚠ There may still be residual steam condensate (or boiler / high temperature water), this residual condensate/water could present a danger of injury. Allow sufficient time for cooling before removing the heating coil from the vessel.

9. Examine the heating coil ('U' tubes) for scale build-up and signs of leakage. If no leakage is detected, carefully clean the excess scale from the coil and prepare for installation. If leakage is detected, either repair the leaking coil(s) or replace the complete coil assembly ('U' tube bundle).
10. Remove the old gaskets and thoroughly clean the mating surfaces on the flange connections and tubesheet. Install two (2) new gaskets as shown in Figure 15.
11. Carefully insert the heating coil assembly into the vessel, ensuring that the divider in the header is aligned with the coil and is parallel to the horizontal.

-
12. After ensuring that the heating coil assembly is correctly aligned, clamp the flanges together and continue with the torque procedure detailed in Section 6.
 - a. Lubricate the bolt threads and the nut faces with a suitable lubricant.
 - b. Insert the bolts through the flanges, then finger tighten the nuts to the bolts.
 - c. Number all the bolts so that torquing requirements can be followed.
 - d. Apply torque to each bolt in twenty percent (20%) increments of the required total torque, loading all bolts at each incremental stage before proceeding to the next increment.
 - e. Use rotational tightening until all bolts are secure at the final torque level. A minimum of two (2) rotations is usually required.
 13. Reconnect the primary steam inlet and condensate outlet lines to the heating coil header. If these lines were broken at additional locations to allow for the removal of the coil, ensure that these are also reconnected. Follow recommendations contained in the manufacturer's documentation, local codes, or accepted practices as to the use and/or type of joint compound or sealer at the connections.
 14. Reconnect the primary steam inlet pressure gauge line (if broken).
 15. Follow the start-up procedure (Section 4.2) to put the unit back on-line.
 16. **Carefully check all connections for any sign of leakage.**

5.4.2 Inlet, outlet and return lines and manual shut-off valves

If the feedwater inlet, plant steam inlet, clean steam outlet or condensate / water return lines or shut-off valves are damaged and must be replaced, follow the procedure outlined below.



The combination of electricity, steam, and water can pose a very dangerous situation. Turn off/disconnect all electric power before attempting any maintenance procedures.

1. Follow the shutdown procedure (Section 4.4) to take the unit off-line before attempting to replace damaged lines or shut-off valves.



While it might seem feasible to replace inlet, outlet and return lines and shut-off valves without shutting down the entire unit, it is not advised. Unless the unit is completely shut down, and the clean steam and primary steam is isolated from the system, failure of a manual shut-off valve during the replacement process could result in serious injury.

2. Ensure that the pressure has been relieved from the clean steam and plant steam systems and that all components and surfaces have cooled.
3. Carefully break the joint between the unit and the pipe or valve to be replaced.
4. Remove the section of pipe or valve to be replaced.
5. Replace the damaged section of pipe or valve.
6. Reconnect the pipe or valve to the unit. Follow recommendations contained in the manufacturer's documentation, local codes, or accepted contractor practices as to the use and/or type of joint compound or sealer at the connections.
7. Follow the start-up procedure (Section 4.2) to put the unit back on-line.

8. Carefully check all connections for any sign of leakage.

5.4.3 Pressure gauge (primary steam) - Figure 17

If the primary steam inlet pressure gauge is not functioning correctly and must be replaced, follow the procedure outlined below.



The combination of electricity, steam, and water can pose a very dangerous situation. Turn off/disconnect all electric power before attempting any maintenance procedures.

1. Follow the shutdown procedure (Section 4.4) to take the unit off-line before attempting to replace the primary steam inlet pressure gauge.
2. Carefully close the pressure gauge isolation valve.
3. Remove the gauge from its mounting and replace with the new gauge.
4. Open the pressure gauge isolation valve. Follow the recommendations contained in the manufacturer's documentation, local codes, or accepted contractor practices as to the use and/or type of joint compound or sealer at the connections.
5. Follow the start-up procedure (Section 4.2) to put the unit back on-line.

6. Carefully check all connections for any sign of leakage.

5.4.4 Steam traps (main and auxiliary) - Figure 16

The main and auxiliary steam traps are installed upstream of the condensate return shut-off valve. If any of the steam traps are not functioning correctly and must be replaced, follow the procedure outlined below.



The combination of electricity, steam, and water can pose a very dangerous situation. Turn off/disconnect all electric power before attempting any maintenance procedures.

1. Follow the shutdown procedure (Section 4.4) to take the unit off-line before attempting to replace the main or auxiliary steam traps.
2. The location of the steam traps can differ between units. Refer to the drawings supplied with the unit to identify the exact location of each trap for the specific unit supplied.
3. Ensure that the pressure has been relieved from the clean steam and primary steam systems and that all components and surfaces have cooled.
4. Carefully break the joints on both the inlet (steam) and outlet (condensate) sides of the trap.
5. Remove and examine the trap. If it is not functioning correctly, it must be repaired or replaced.
6. To refit the trap, re-align with the system pipework and re-connect to the inlet and outlet lines, following the recommendations contained in the manufacturer's documentation, local codes, or accepted contractor practices as to the use and/or type of joint compound or sealer at the connections.
7. Follow the start-up procedure (Section 4.2) to put the unit back on-line.
8. **Carefully check all connections for any sign of leakage.**

Steam traps

Fig. 16

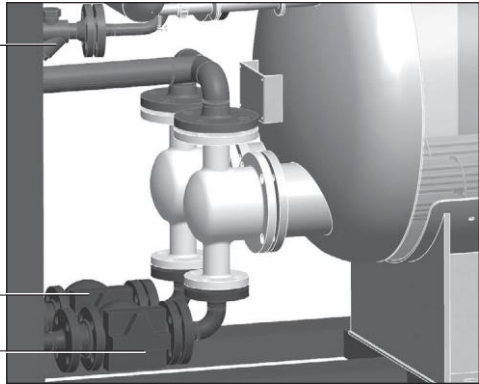

5.4.5 Strainers - Figure 17

Strainers are installed on the unit and must be checked and cleaned periodically (approximately every twelve months) to prevent the build-up of any sediment.

⚠ The combination of electricity, steam, and water can pose a very dangerous situation. Turn off/disconnect all electric power before attempting any maintenance procedures.

1. Follow the shutdown procedure (Section 4.4) to take the unit off-line before attempting to replace the strainers.
2. The location of the strainers can differ between units. Refer to the drawings supplied with the unit to identify the exact location of each strainer for the specific unit supplied.
3. Ensure that the pressure has been relieved from the clean steam and plant steam systems and that all components and surfaces have cooled.
4. Carefully break the line connections on both the inlet and outlet side of the strainer.
5. Remove and examine the strainer for any sediment that may be present. If it cannot be satisfactorily cleaned, it must be replaced.
6. To refit the strainer, re-align with the system pipework and re-connect to the inlet and outlet pipes, following the recommendations contained in the manufacturer's documentation, local codes, or accepted contractor practices as to the use and /or type of joint compound or sealer at the connections.
7. Follow the start-up procedure (Section 4.2) to put the unit back on-line.
8. **Carefully check all connections for any sign of leakage.**

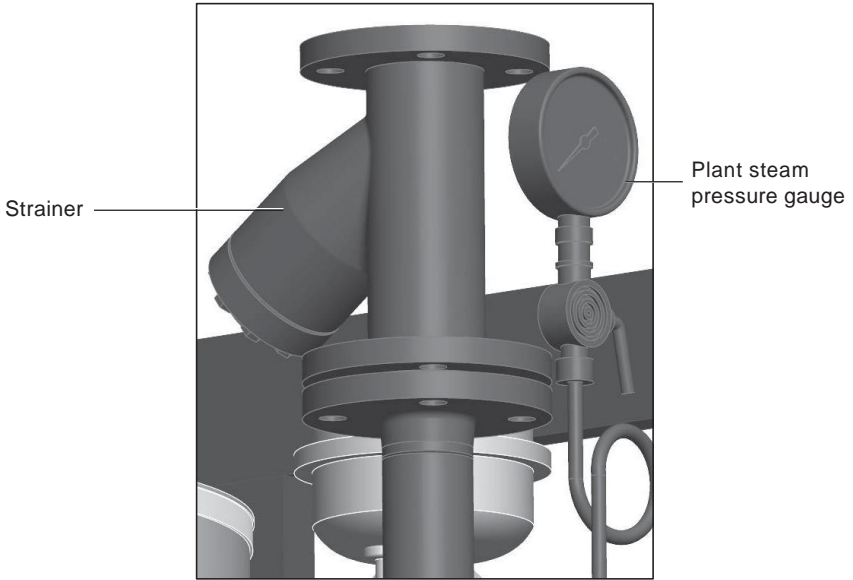



Fig. 17

5.4.6 Pressure safety switch - Figure 18

-  **The clean steam and plant steam systems can be very dangerous because of the high temperatures and pressures. To avoid possible injury or death, follow all accepted and recommended procedures when performing installation, operation and maintenance procedures.**

-  **The combination of electricity, steam, and water can pose a very dangerous situation. Turn off/disconnect all electric power before attempting any maintenance procedures.**

The safety pressure switch acts as a fail-safe for Spirax Sarco compact clean steam generators. The alarm and shut down for high pressure is set at a value lower than that which has been set for the safety valve. It requires power to operate, therefore in the case of a power failure, the unit will totally shut down. If it is mandatory that the unit remain in operation during power failures, it should be wired into the emergency power system. If the pressure safety switch is not functioning correctly and must be replaced, follow the procedure outlined below.

1. Follow the shutdown procedure (Section 4.4) to take the unit off-line before attempting to replace the safety pressure switch.
2. Ensure that the pressure has been relieved from the clean steam and plant steam systems and that all components and surfaces have cooled.

3. Carefully disconnect the wires leading from / to the control cabinet.
4. Loosen the connections until the pressure probe can be removed.
5. Examine the probe for damage or incorrect positioning. For the exact procedure for examination refer to the Spirax Sarco product specific installation and maintenance manual supplied with the unit.
6. To install a new unit, follow the recommendations in the manufacturer's documentation.
7. After ensuring that the unit is correctly installed, tighten the fittings and sanitary connections using new sanitary type gaskets where required.
8. Follow the start-up procedure (Section 4.2) to put the unit back on-line.
9. **Carefully check all connections for any sign of leakage.**

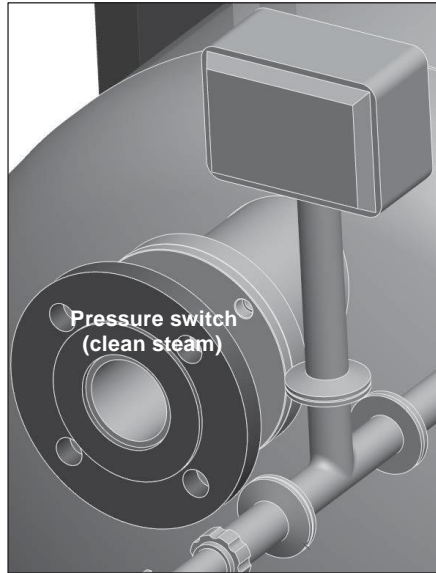

Fig. 18

5.4.7 Steam pressure transmitter - Figure 19

⚠ The clean steam and primary steam systems can be very dangerous because of the high temperatures and pressures. To avoid possible injury or death, follow all accepted and recommended procedures when performing installation, operation, and maintenance procedures.

⚠ The combination of electricity, steam, and water can pose a very dangerous situation. Turn off/disconnect all electric power before attempting any maintenance procedures.

The steam pressure transmitter monitors and controls outlet clean steam pressure by sending a signal to the PLC control unit which is used to adjust the plant steam supply control valve position and modulate the flow of steam into the heating coils.

It requires power to operate, therefore in the case of a power failure, the unit will totally shut down. If it is mandatory that the unit remains in operation during power failures, it should be wired into the emergency power system.

If the pressure transmitter is not functioning correctly and must be replaced, follow the procedure outlined below.

1. Follow the shutdown procedure (Section 4.4) to take the unit off-line before attempting to replace the steam pressure transmitter.
2. Ensure that the pressure has been relieved from the clean steam and plant steam systems and that all components and surfaces have cooled.
3. Carefully disconnect the wires leading from / to the control cabinet.
4. Loosen the connections until the transmitter can be removed. Examine the probe for damage or incorrect positioning. For the exact procedure for examination refer to the Spirax Sarco product specific Installation and Maintenance manual supplied with the unit.
5. To install a new unit follow the recommendations contained in the manufacturer's documentation.
6. After ensuring that the unit is correctly installed, tighten the fittings and sanitary connections using new sanitary type gaskets where required.
7. Follow the start-up procedure (Section 4.2) to put the unit back on-line.
8. **Carefully check all connections for any sign of leakage.**

Fig. 19

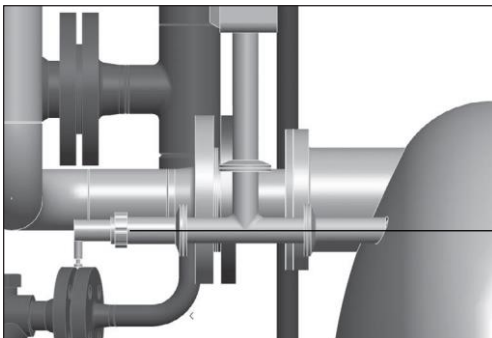

Pressure transmitter
(clean steam)

5.4.8 Pressure safety valve (generator) - Figure 20

The pressure safety valve acts as a fail-safe for Spirax Sarco compact clean steam generators. The valve will open for high pressure to protect the system from explosion. If the pressure safety valve is not functioning correctly and must be replaced, follow the procedure outlined below.

⚠ The combination of electricity, steam, and water can pose a very dangerous situation. Turn off/disconnect all electric power before attempting any maintenance procedures.

1. Follow the shutdown procedure (Section 4.4) to take the unit off-line before attempting to replace the pressure safety valve.
2. After ensuring that the pressure has been relieved from the clean steam and plant steam systems and that all components and surfaces have cooled, disconnect the vent line leading from the pressure safety valve to atmosphere (usually through the roof), and the drain line.
3. Carefully disconnect the pressure safety valve from the generator vessel.
4. Install the new valve following the recommendations contained in the manufacturer's documentation, local codes, or accepted contractor practices as to the use of joint compound or sealer at the connections.
5. Reconnect the vent line leading from the pressure safety valve to atmosphere and the drain line.
6. Follow the start-up procedure (Section 4.2) to put the unit back on-line.
7. **Carefully check all connections for any sign of leakage.**

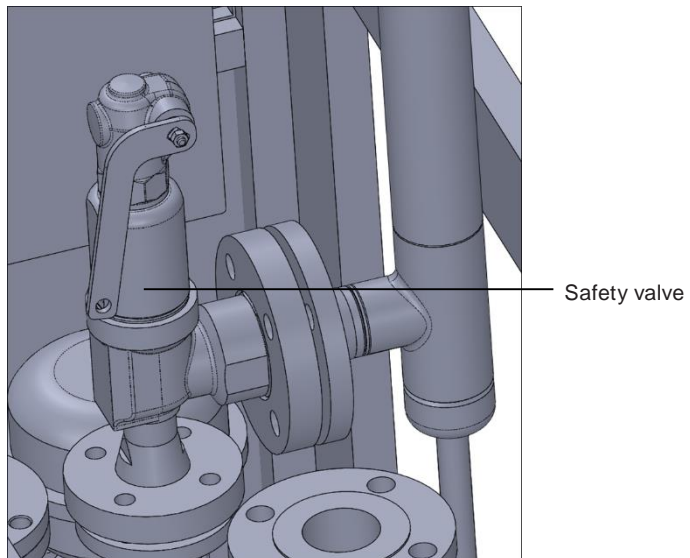

Fig. 20

5.4.9 Pressure gauge (clean steam/feedwater) - Figure 21

If the feedwater inlet or clean steam outlet pressure gauges are not functioning correctly and must be replaced, follow the procedure outlined below.

⚠ The combination of electricity, steam, and water can pose a very dangerous situation. Turn off/disconnect all electric power before attempting any maintenance procedures.

1. Follow the shutdown procedure (Section 4.4) to take the unit off-line before attempting to replace the pressure gauge.
2. Carefully close the pressure gauge isolation valve.
3. Remove the gauge from its mounting and replace with the new gauge (sanitary type).
4. Open the pressure gauge isolation valve. Follow the recommendations contained in the manufacturer's documentation, local codes, or accepted contractor practices as to the use and/or type of joint compound or sealer at the connections.
5. Follow the start-up procedure (Section 4.2) to put the unit back on-line.
6. **Carefully check all connections for any sign of leakage.**

Clean steam pressure gauge
(actual location is in the vertical run)



Feedwater pressure gauge

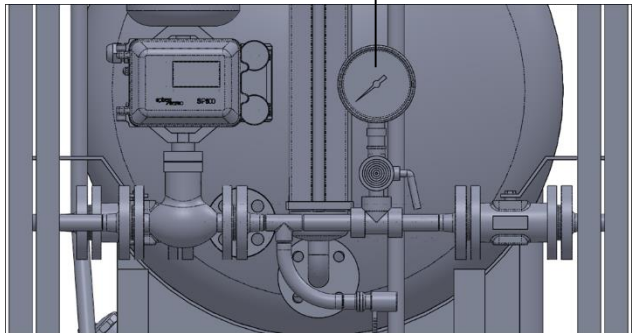

Fig. 21

5.4.10 Level controller - Figure 22

The level controller supplied on the CSM-C compact clean steam generator controls the level of the water within the unit, ensuring that the unit will function safely and effectively. If the level controller must be removed for inspection, adjustment, or replacement, follow the procedure outlined below.

⚠ The clean steam and primary steam systems can be very dangerous because of the high temperatures and pressures. To avoid possible injury or death, follow all accepted and recommended procedures when performing installation, operation, and maintenance procedures.

⚠ The combination of electricity, steam, and water can pose a very dangerous situation. Turn off/disconnect all electric power before attempting any maintenance procedures.

1. Follow the shutdown procedure (Section 4.4) to take the unit off-line before attempting to remove and inspect the level controller.
2. Ensure that the pressure has been relieved from the clean steam and plant steam systems and that all components and surfaces have cooled.
3. If the level controller is not completely drained and bled, steam or boiling water may be discharged.
4. Disconnect the wires leading from the control cabinet.
5. Disconnect the level controller from the vessel.
6. Continue to loosen the connections until the level controller can be removed.
7. Examine the level probes / gauge for damage or incorrect positioning. For the exact procedure for examination refer to the Spirax Sarco product specific Installation and Maintenance manual supplied with the unit.
8. To reinstall the level controller, align with the feed lines and start refitting following the recommendations contained in the supplied documentation.
9. After ensuring that the level controller is correctly aligned, tighten the fittings.
10. Follow the start-up procedure (Section 4.2) to put the unit back on-line.
11. **Carefully check all connections for any sign of leakage.**

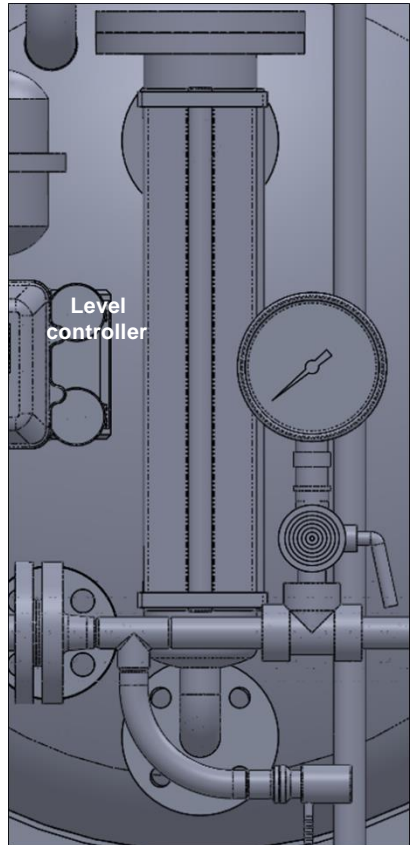

Fig. 22

5.4.11 Piston valves - Figure 23

The product specific documentation included with the unit provides the relevant operation and maintenance instructions for the bottom blowdown piston valve. The drawing included with the unit will give the exact location, as well as connection with other components. This information should be reviewed before removal / replacement of any valves.

⚠ The clean steam and primary steam systems can be very dangerous because of the high temperatures and pressures. To avoid possible injury or death, follow all accepted and recommended procedures when performing installation, operation, and maintenance procedures.

⚠ The combination of electricity, steam, and water can pose a very dangerous situation. Turn off/disconnect all electric power before attempting any maintenance procedures.

1. Follow the shutdown procedure (Section 4.4) to take the unit off-line before attempting to remove and inspect the piston valve.
2. Ensure that the pressure has been relieved from the clean steam and plant steam systems and that all components and surfaces have cooled.
3. If the unit is not completely drained and bled, steam or boiling water may be discharged.
4. Disconnect the wires leading from / to the control cabinet, turn off the instrument air source, bleed the pressure from the line, and disconnect the lines to the valve.
5. Disconnect at the joint.
6. Continue to loosen the connections until the valve can be removed.
7. Examine the valve for damage or incorrect positioning. For the exact procedure for examination refer to the Spirax Sarco product specific Installation and Maintenance manual supplied with the unit.
8. To install a new valve, follow the recommendations contained in the relevant supplied documentation.
9. After ensuring that the valve is correctly aligned, tighten the fittings.
10. Follow the start-up procedure (Section
11. 4.2) to put the unit back on-line.
12. **Carefully check all connections for any sign of leakage.**

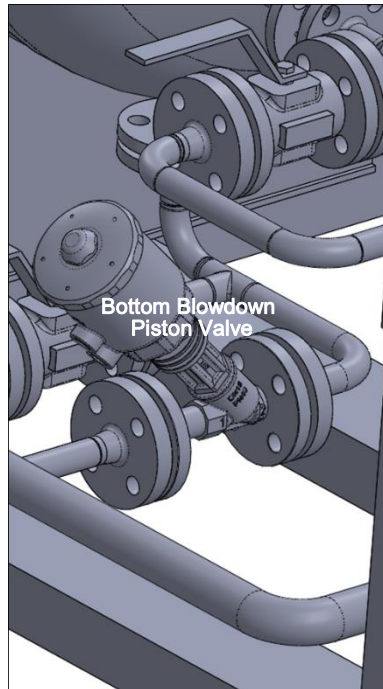

Fig. 23

5.4.12 Pneumatic (modulating) control valve - Figure 24

Pneumatic (modulating) control valves are installed on the plant steam inlet pipe and feedwater inlet pipe of the generator vessel.

The control valves each comprise a SPIRA-TROL series valve fitted with a PN9000 series pneumatic actuator and an SP500 electro pneumatic smart positioner. The drawings and documentation included with the unit provide specific instructions for the safe installation, operation and/or maintenance of each component and its exact location. This information should be reviewed and the shutdown (Section 4.4) and start-up (Section 4.2) procedures followed during removal or replacement of the component.

For control valve instructions, refer to IM-S24-42 & IM-P305-06-US

For actuator instructions, refer to IM-P357-29

For positioner instructions, refer to IM-P343-35

During normal operation, some general routine maintenance is also required as outlined below.

 **The clean steam and primary steam systems can be very dangerous because of the high temperatures and pressures. To avoid possible injury or death, follow all accepted and recommended procedures when performing installation, operation, and maintenance procedures.**

 **The combination of electricity, steam, and water can pose a very dangerous situation. Turn off/disconnect all electric power before attempting any maintenance procedures.**

Daily:

To ensure satisfactory operation, it is strongly recommended that the control signal air is filtered and supplied dry and free of oil. Bleed the air filter regulator by holding open the tap located on the bottom of the catch basin until any water, oil or other impurities have completely drained away.

After 24 hours:

Check all pipework connections and flange bolts for tightness. For valves packed with graphite gland seals, tighten the gland nut by approximately $\frac{1}{4}$ of a turn taking care not to over-tighten as this may cause excessive friction on the valve stem during operation.

At 3 monthly intervals:

Visually inspect all gland seals for signs of leakage and if necessary take the following corrective actions:-

For valves packed with PTFE gland seals - remove and replace the seals.

For valves packed with graphite gland seals - tighten the gland nut by approximately $\frac{1}{4}$ of a turn taking care not to over-tighten as this may cause excessive friction on the valve stem during operation. If no adjustment is possible, remove and replace the seals.

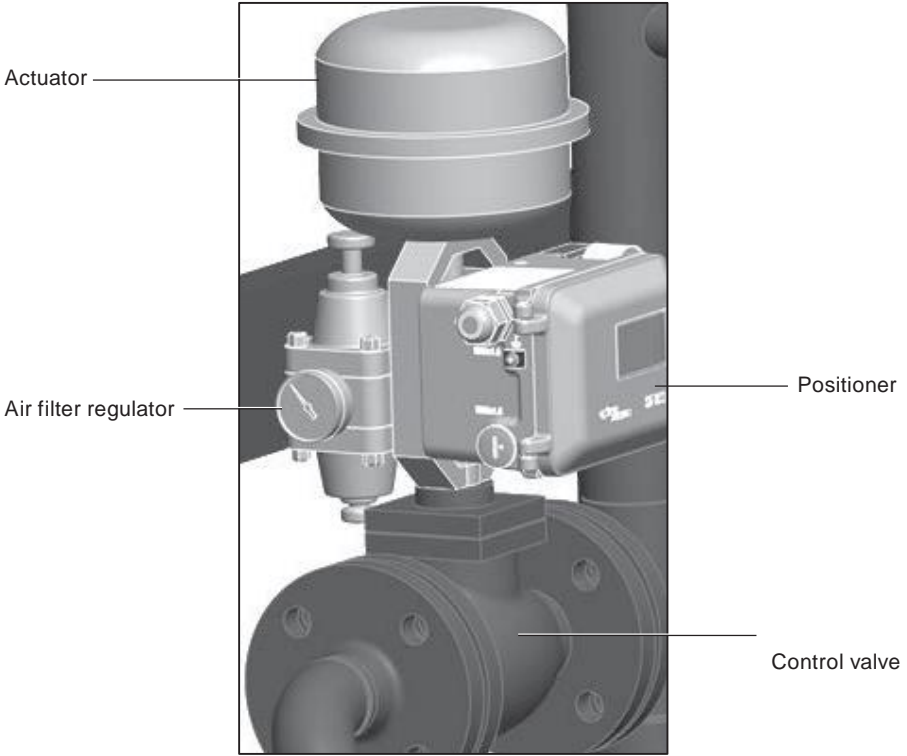

Fig. 24

5.4.13 Control cabinet - Figure 25

The control cabinet provides full control of the Spirax Sarco CSM-C compact clean steam generator operating system. The system requires power to operate, therefore in the case of a power failure, the system will totally shut down the unit. If it is mandatory that the unit remains in operation during power failures, it should be wired into the emergency power system.

Before this is done, it is the duty of the installer / operator or Safety officer to check local codes and requirements to ensure that this is an acceptable configuration.

The system should be checked twice yearly (see the documentation for the system provided with the unit for the specific inspection intervals and test routine). If the system is found to be malfunctioning and it is not possible to identify the fault, the unit must be replaced. To replace the unit please follow the procedure outlined below:

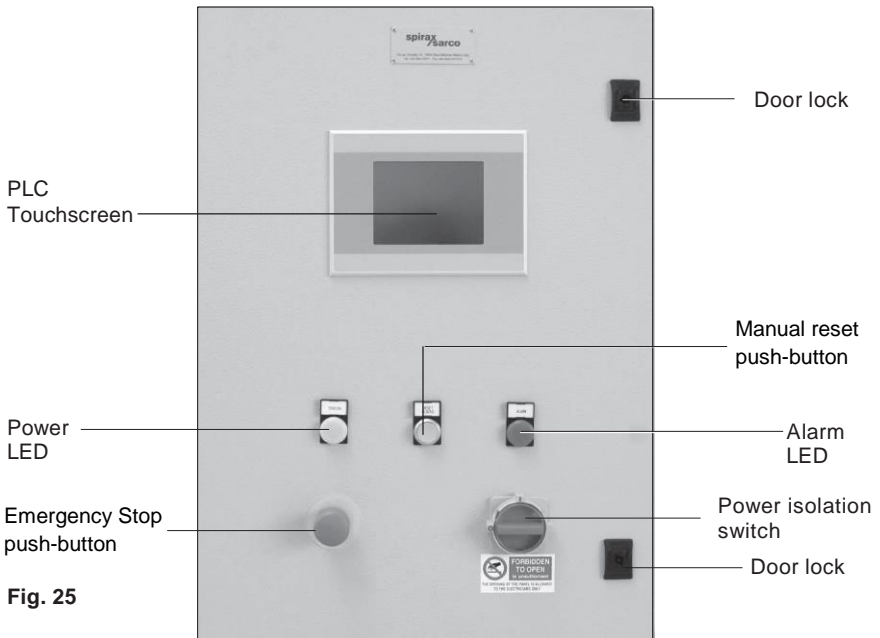

Fig. 25

⚠ Note: The exact location and configuration of the solenoid safety system can vary between units. See the drawing and design specifications supplied with the unit for the exact placement and configuration.

⚠ The combination of electricity, steam, and water can pose a very dangerous situation. Turn off/disconnect all electric power before attempting any maintenance procedures.

1. Follow the shutdown procedure (Section 4.4) to take the unit off-line before attempting to change any part of the system.
2. Refer to Spirax Sarco technical department for repair or replacement.
3. Follow the start-up procedure (Section 4.2) to put the unit back on-line.
4. **Carefully check all connections for any sign of leakage.**

5.5 Recommended maintenance schedule

Description	Months				
	1	3	6	12	24

Generator

Remove and inspect the level controller. Refit and check calibration.			•		
Remove and inspect the pressure transducer. Refit with new gasket and check calibration.			•		
Remove, strip and inspect the water inlet control valve. Replace all seals and refit with new gaskets.				•	
Remove, strip and inspect the steam inlet control valve. Replace all seals and refit with new gaskets.				•	
Check operation of the SP500 positioner.			•		
Remove, strip and inspect the bottom blowdown control valve (if fitted). Replace all seals and refit with new gaskets.				•	
Remove and inspect the primary steam heating coil(s). Refit with new gaskets.					•
Remove and inspect the generator air vent. Refit with new gaskets.				•	

General

Remove and inspect all steam traps. Refit with new gaskets.				•	
Remove and inspect all pressure gauges. Refit with new gaskets.				•	
Remove and inspect the steam supply strainer screen. Refit with new gasket.				•	
Check the conductivity of the water in the generator.	•				
Carry out steam quality test.		•			
Check all electrical connections.				•	
Carry out full functional check, testing all alarms and operating parameters are correct.		•			

Note: The Safety valve is factory set at a predetermined limit and requires no maintenance.

6. Bolt torques

Description	Connection Size	Torque (Nm)	Torque (lb ^f ft.)
Tube Bundle Head	NA	101.0	74.5
Plant Steam Inlet	2" ANSI 150 RF	218.8	161.3
Condensate Outlet	2" ANSI 150 RF	218.8	161.3
Feedwater Inlet	½" ANSI 150 RF	38.3	28.3
Clean Steam Outlet	3" ANSI 150 RF	203.6	150.2
Safety Valve Discharge	2" ANSI 150 RF	179.6	132.5
Vessel Drain/Blowdown	1" ANSI 150 RF	69.9	51.5

7. Spare parts

The following is a list of parts that are generally replaceable, by trained / certified personnel, on Spirax Sarco CSM-C compact clean steam generators. However, a full list of the available spares can be provided on request. **The replaceable parts may vary, depending on the unit and the particular design specifications** to which the unit was constructed. If there are questions concerning the replaceable parts for the unit, refer to the original design specifications, or contact Spirax Sarco.

Please have the unit's model number and serial number available when contacting Spirax Sarco (see Section 2.4).

Available spares:

- Pressure control valves
- Gaskets
- Heating coils
- Level controller
- Clean steam pressure gauge
- Primary supply steam pressure gauge
- Pressure safety valve
- Control system
- Strainers
- Primary side steam traps

How to order spares

Example: 1 off Level controller for a Spirax Sarco CSM-C compact clean steam generator.

Serial number of the generator unit (see Section 2.4):

.....

Serial number (if available) and / or nomenclature (or description) of the component requiring part(s) or replacement:

.....

Repairs

To request a site service or return components for replacement, please contact your nearest Spirax Sarco Hub Office or directly at:

Spirax Sarco, Inc.
1150 Northpoint Blvd, Blythewood, SC 29016
Tel: 800 833 3246
Fax: 803 714 2221
Email: Tsupport@spirax.com

8. Fault finding

The following table summarizes problems that may be encountered during the life of a CSM-C 600 compact clean steam generator, and the procedures to remedy those problems.

Symptom	Cause	Remedy
1 The generator water level is too low. The generator is in alarm condition.	<p>The drain or bottom blowdown valves are open.</p> <p>Feedwater isolation valve is closed.</p> <p>Feedwater control valve is closed.</p> <p>The water level gauge or controller is damaged or faulty</p> <p>Feedwater pressure is too low.</p>	<p>Close drain/bottom blowdown valves</p> <p>Open feedwater isolation valve</p> <p>Check that air is being supplied to the actuator and is at the correct pressure.</p> <p>Manually operate the valve via the generator synoptic screen on the controller.</p> <p>Replace the level controller. See Section 5.4.10 of this manual</p> <p>Check feedwater pressure.</p>

<p style="text-align: center;">2</p> <p>The generator water level is too high. The generator is in alarm condition.</p>	<p>The feedwater control valve has failed to close.</p> <p>The water level controller is damaged and giving a false reading.</p> <p>Steam from a second generator is feeding back into the generator shell and condensing.</p>	<p>Check that air is being supplied to the actuator and is at the correct pressure.</p> <p>Manually operate the valve via the generator synoptic screen on the controller.</p> <p>Isolate the feedwater system and inspect the valve seat for signs of damage (see appropriate Installation and Maintenance Instructions).</p> <p>Replace the level controller. See Section 5.4.10 of this manual.</p> <p>Check that the non-return valve is operating correctly.</p> <p>Contact Spirax Sarco Service Department.</p>
---	--	---

Symptom	Cause	Remedy
<p style="text-align: center;">3</p> <p>The generator pressure is too low. The low pressure alarm has activated.</p>	<p>Plant steam is not reaching the control valve.</p> <p>The plant steam control valve is closed.</p> <p>The condensate is not being removed from the heating coil(s).</p> <p>The generator pressure transducer is damaged and giving a false reading.</p>	<p>Check that the plant steam supply has not been isolated.</p> <p>Check that air is being supplied to the actuator and that the air supply pressure is correct.</p> <p>Manually operate the valve via the generator synoptic screen on the controller.</p> <p>Check that the steam traps are operating correctly.</p> <p>Check that the condensate isolation valves are open.</p> <p>Replace the pressure transducer.</p> <p>Contact Spirax Sarco Service Department.</p>
<p style="text-align: center;">4</p> <p>The generator pressure is too high. The generator is in alarm condition.</p>	<p>The plant steam control valve has failed to close.</p> <p>The steam supply pressure exceeds the maximum differential pressure of the valve.</p> <p>The pressure transducer is damaged and giving a false reading.</p>	<p>Isolate the plant steam supply and inspect the valve seat for signs of damage (see appropriate Installation and Maintenance Instructions).</p> <p>Check the plant steam supply pressure.</p> <p>Replace the pressure transducer.</p> <p>Contact Spirax Sarco Service Department.</p>

Symptom	Cause	Remedy
<p style="text-align: center;">5</p> <p>The controller touch screen is blank and does not respond when touched.</p>	<p>Power has failed.</p>	<p>Check that the electrical power is on.</p> <p>Contact Spirax Sarco Service Department.</p>
<p style="text-align: center;">6</p> <p>The generator is unable to maintain pressure when operating on full-load conditions.</p>	<p>The plant steam supply pressure is too low.</p> <p>The condensate is not being removed from the heating coil(s).</p> <p>The heating coil(s) are becoming scaled so the heat transfer efficiency is reduced.</p> <p>The clean steam load is exceeding the design specification of the generator.</p>	<p>Check that the plant steam supply pressure is correct and does not reduce as the generator load increases.</p> <p>Check that the steam traps are operating correctly.</p> <p>Check that the condensate isolation valves are open.</p> <p>Remove and examine the coil(s). See section 5.4.1 of this manual.</p> <p>Check the actual steam load against the original specification.</p> <p>Contact Spirax Sarco Service Department.</p>

9. Warranty

Spirax Sarco, Inc. warrants to the original user, that the CSM-C 600 Clean Steam Generator, being used in the service and the manner for which it was intended, shall be free from defects in material and workmanship for a period of 12 months from date of commissioning and no longer than 18 months from the date of shipment from the factory. The validity of this warranty is subject to the completion of the mandatory commissioning and start-up service performed by a Spirax Sarco Service Technician. This warranty does not extend to any product that has been subject to misuse, neglect or alteration after shipment from the Spirax Sarco factory, except as may be expressly provided in a written agreement between Spirax Sarco, Inc. and the user and which is signed by both parties. The use of the CSM-C 600 Clean Steam Generator with poor quality feed water that does not meet the minimum feed water quality requirements as published by Spirax Sarco will be considered misuse and neglect and will void the warranty. Defective components or assemblies found during the warranty period may be repaired or replaced at the discretion of Spirax Sarco and must be completed by a Spirax Sarco service technician or qualified representative; otherwise the warranty will be terminated. The partial or total failure to follow the instructions given in this manual completely invalidates the warranty.